

INFLUENCE OF BUCKET WHEEL VERTICAL VIBRATION ON BUCKET-WHEEL EXCAVATOR (BWE) DIGGING FORCE

Zoran Golubović, Zlatibor Lekić, Srdjan Jović

Original scientific paper

This paper provides a method of determining the BWE digging force considering the characteristics of soil which needs to be excavated, bucket cutting contour, cutting speed and vertical vibration of the bucket wheel. Digging force depends on the specific force resistance to excavation (SFRE) and the total length of buckets cutting contours that are simultaneously in mesh with the material. The SFRE is conditioned by the characteristics of material, cutting speed and it is random variable, while the total length of buckets cutting contours depends on the number of buckets that are simultaneously in mesh with the soil and vertical oscillations of the bucket wheel. Total length of buckets cutting contours time function is determined considering moving of bucket wheel center point, based on a dynamic model of BWE in the vertical plane.

Keywords: bucket-wheel excavator, vertical vibration, digging force, dynamic model

Utjecaj vertikalnih vibracija rotora na silu kopanja rotornog bagera

Izvorni znanstveni članak

Ovaj rad daje postupak određivanja sile kopanja rotornog bagera uzimajući u obzir karakteristike kopanog materijala, rezu ivicu lopatice, brzinu rezanja i vertikalne vibracije radnog kotača (rotora). Sila kopanja ovisi o specifičnom otporu kopanju (SOK) i ukupnoj duljini reznih rubova lopatice koje su istovremeno u zahvatu s kopanim materijalom. SOK je uvjetovan karakteristikama kopanog materijala, brzine rezanja i slučajna je veličina, dok ukupna duljina reznih rubova lopatice ovisi o broju lopatica koje su istovremeno u zahvatu s kopanim materijalom i vertikalnim vibracijama radnog kotača. Funkcija promjene ukupne duljine reznih rubova lopatica u ovisnosti od vremena dobivena je na osnovu dinamičkog modela rotornog bagera u vertikalnoj ravni, uzimajući u obzir pomak središta radnog kotača.

Ključne riječi: rotorni bager, vertikalne vibracije, sila kopanja, dinamički model

1

Introduction

Mathematical modelling of digging forces at bucket wheel excavator working wheel is difficult with a large number of factors that influence excavation process [14]. Main factors are: characteristics of soil to be excavated, bucket cutting contour, bucket volume, cutting speed, shape and condition of tooth, etc. Characteristics of soil are represented by specific resistance to excavation (SFRE) reduced on unit chip section area and unit length of cutting contour. According to [6], advantage of SFRE reduced to cutting length (k_L) is its independence of chip cross section area and shape. In reference [4] is represented the procedure to determine the SFRE, but without influence of cutting speed. According to researches [5], value of SFRE is greatly influenced by cutting speed, too. From either side cutting contour depends on bucket wheel vibrations in vertical plane. These vibrations are caused by digging forces and superstructure vibrations of its own [13]. Influence of superstructure vibrations on the chip dimensions is discussed in references [2, 12]. Dynamic models of digging [16, 17, 18, 20, 21], lifting [9] and superstructure [3] subsystems in this paper are combined through a mathematical model or a single program. The results obtained using the dynamic model presented in this paper, in addition to other extensive diagnostic testing [15], can be used to identify the optimal retrofit solution [8]. Theoretical knowledge concerning vibro-impact dynamics system [11] is used for digging forces analysis. Dynamic model presented in this paper was tested on the SRs 1300 TAKRAF BWE.

2

Digging force

Digging force has a key effect on the dynamic behaviour of the bucket wheel drive system [18]. In relation to the total power that motor torque must overcome the digging force is the biggest. At a very hard massive excavation lifting to the point of discharge consumes less than 10 % of total power, which clearly indicates the need for a comprehensive analysis of the digging forces.

Digging force can be presented as the sum of the following: cutting force, friction force and inertial force. It is spatial, non-stationary and stochastic. Number of influential parameters, whose individual contribution is very different and mutually conditioned, affects on her character. Experimental methods are mainly in use for isolation and determination of the most important impact.

To facilitate the analysis of digging the force should be seen by components in the corresponding planes. First will be seen tangential component of digging force in the vertical plane, as the largest one (Fig. 1).

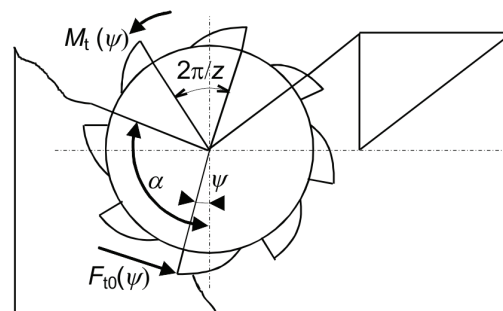

Figure 1 Tangential component of a bucket digging force

Tangential component of a bucket digging force according to [1] is given by the following equation:

$$F_{t0}(\psi) = k_0 L_0 f_0(\psi), \tag{1}$$

where is:

$$f_0(\psi) = \begin{cases} \sin \psi & \text{for } 0 \leq \psi \leq \pi/2 \\ (\alpha - \psi)/(\alpha - \pi/2) & \text{for } \pi/2 \leq \psi \leq \alpha \\ 0 & \text{for } \psi > \alpha \end{cases}$$

$k_0 = random[k_L]$ - Randomly selected value from a range of SFRE measured values.

L_0 - Length of a bucket cutting contours.

Based on the measuring results of the SFRE, and according to equation (1) force on the bucket cutting contours is mathematically modelled. By multiplying the length of the bucket cutting contours with randomly selected value $k_0 = random[k_L]$ from a range of SFRE measured for adequate working conditions, tangential force according to selected position of bucket is calculated. Repeating this procedure with a new position of the bucket defined by angle ψ and a new selection of random values for SFRE from series of measurements will be calculated a new value of the tangential force. Modelling is continued based on the same principle for all buckets which are included in contact with soil. Summing up the values of the ordinate cumulative tangential force time function is obtained:

$$F_t(t) = [k] \sum_{i=0}^n L_i f_i(t), \tag{2}$$

n – number of buckets that are simultaneously in mesh with the soil.

Where is:

$$L_{tot} = \sum_{i=0}^n L_i f_i(t), \tag{2a}$$

L_{tot} – time function of buckets cutting contours total lengths that are simultaneously in mesh with the soil.

2.1 Specific resistance to excavation (SFRE)

Ignoring any additional interaction between cutting contours and soil, it can be said that the digging force results mainly from the mechanical properties of the soil, which is mathematically expressed by the SFRE. As the SFRE is random variable, its value in the process of digging can be obtained only by measuring. However, despite its random nature, there are appropriate rules that can help in modelling the SFRE and the digging force:

- Jumps occur in small intervals, separately, not at once for each bucket in mesh with the Soil.

- In inhomogeneous soil less SFRE values correspond to a smaller number of hard pieces inclusions.
- Increasing thickness of cutting layer results in some reduction in SFRE.
- The number of observed jumps corresponds to the Poisson distribution, which means that:
 1. number of jumps is independent random value,
 2. likelihood of the same number of jumps in an interval is constant and
 3. jumps in smaller intervals are individual.

Experimentation [7] obtained the values of digging SFRE in the Kosovo coal basin [10] for gray compact clay excavation and measurement results are presented graphically in Fig. 2.

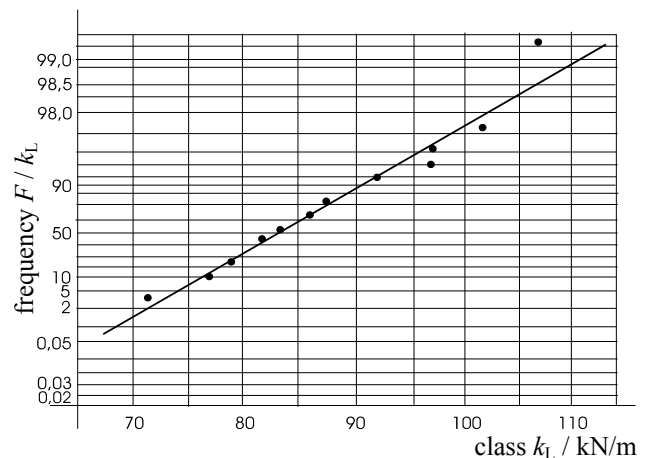

Figure 2 Values of SFRE at the Kosovo coal basin

2.2 Length of buckets cutting contours

Buckets cutting contours length is variable and depends primarily on the number of buckets that are simultaneously in mesh and slice geometry. Based on expression (2) it is graphically interpreted in Fig. 3.

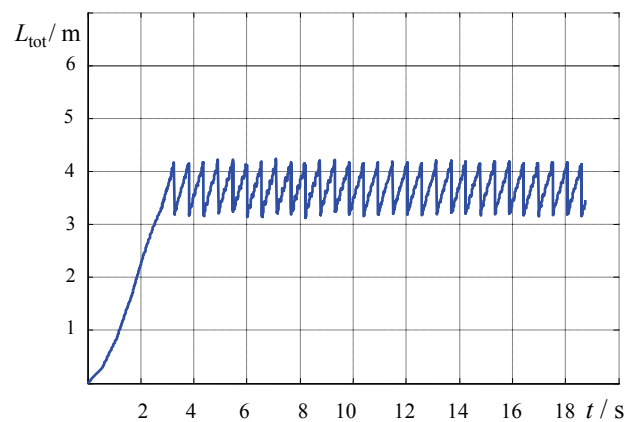

Figure 3 Total length of buckets cutting contours that are simultaneously in mesh with the Soil

Fig. 3 shows the time function of buckets cutting contours total length where oscillation of bucket wheel in the vertical plane is not included. Its jagged character is

conditioned by the cyclical buckets entry and exit in digging process.

Determination of the vertical movement of bucket wheel by taking into account the inhomogeneity of the soil and stochastic digging force is only possible by simultaneously solving the system of differential equations which describe the oscillation of the lifting subsystems elements, bucket wheel drive system and supporting structure of bucket wheel excavator.

3 Dynamics model of bucket wheel excavator

Fig. 4 shows the kinematics scheme of the boom lifting drive system, consisting of the following: an asynchronous electric motor (EM), mechanical coupling (S), gearbox (R), brakes (K) and drum for rope winding (D). Interesting for this work is the case where the balance is established between the braking and load torque. Only a few teeth coupled due changeable nature of the torque load at the catch. This leads to very rapid wear of the gears tooth flanks, and therefore to a relatively small gear life. Oscillatory system of boom lifting drive

system motion [9] is represented as four rotating masses on a single shaft wedged (Fig. 4a):

J_k – break moment of inertia,

J_r – the reduced gearbox moment of inertia on the shaft brake,

J_5 – the reduced gear number 5 moment of inertia on the shaft brake,

J_6 – the reduced gear number 6 and drum moment of inertia on the shaft brake.

Dominant influence of the oscillations of the system has upper supporting structure. According to analysis [3], the upper supporting structure accumulates around 85 %, portal sheet 10 %, suspension system about 3 % while all other substructure (boom, bucket wheel drive system and lower supporting structure) accumulate less than 1 % of the system potential energy in its oscillations. Those facts suggest that in the analysis of the systems low-frequency oscillations, the deformability of the lower support structure can be ignored.

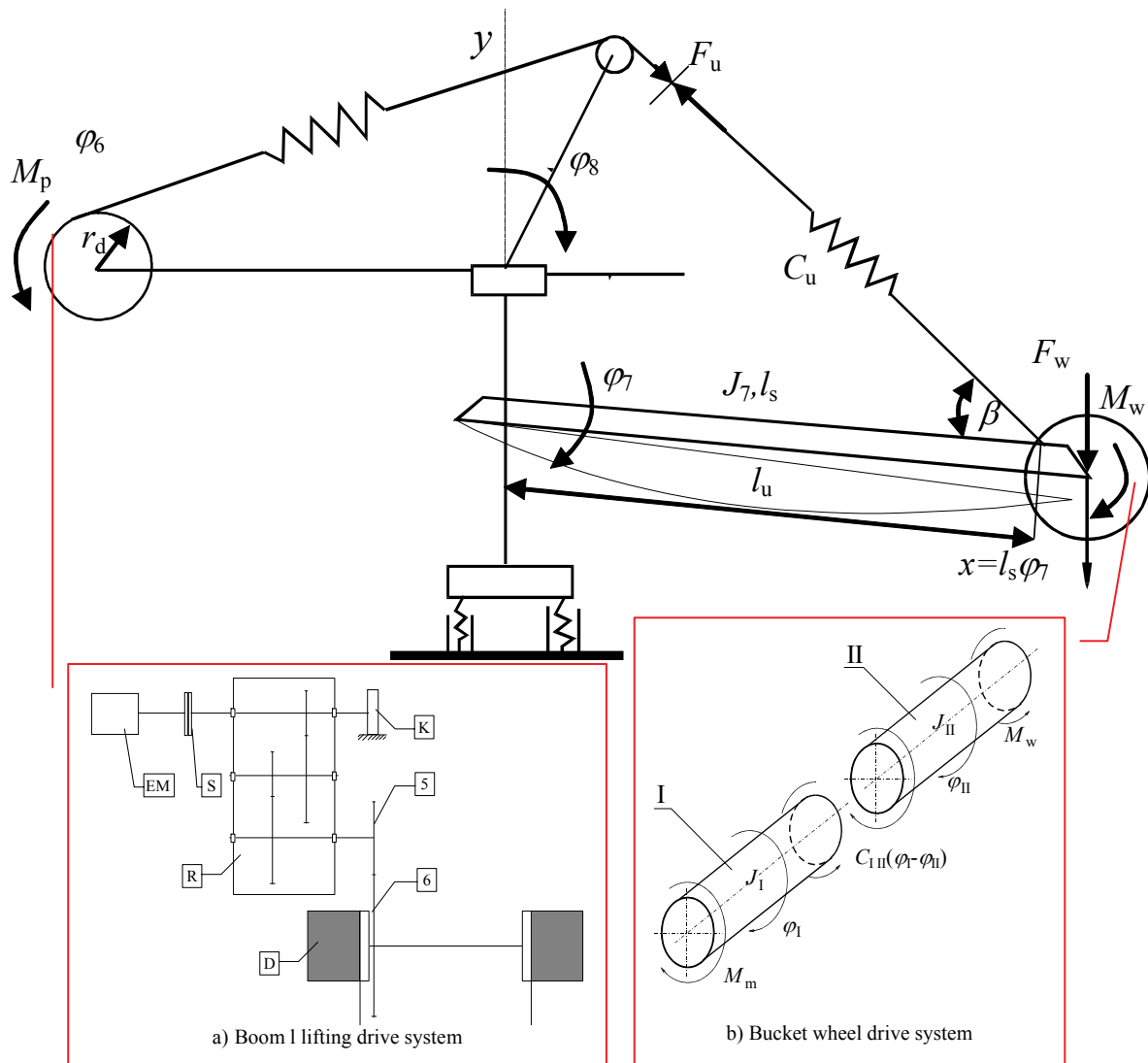

Figure 4 Mechanical model of bucket wheel excavator

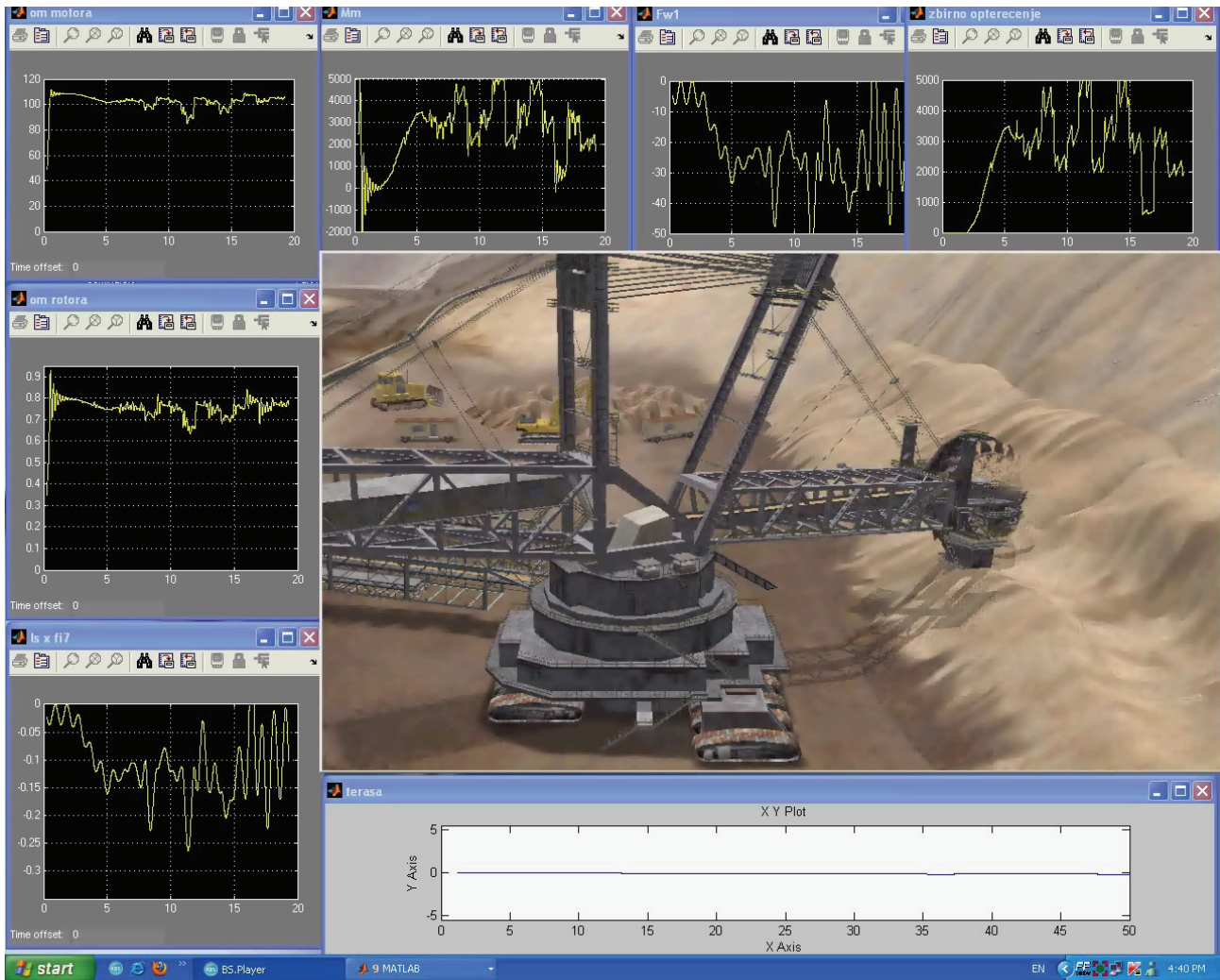
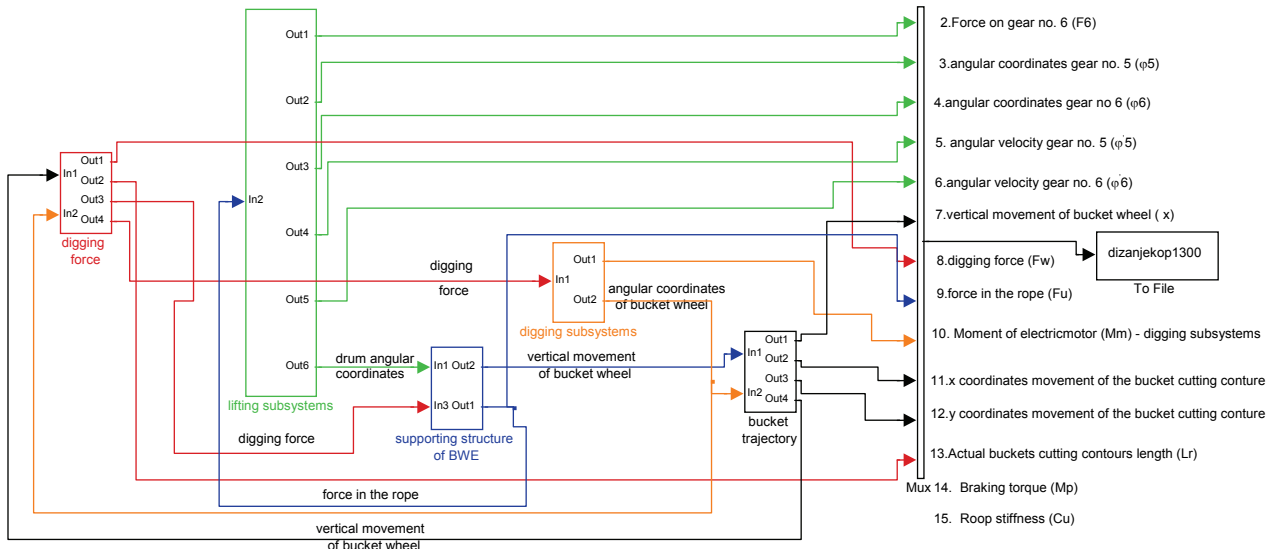

Figure 5 Simulink model of BWE dynamics model

Oscillatory system of BWE supporting structure [3] is represented as two rotating masses:
 J_7 – boom and bucket wheel moment of inertia on.
 J_8 – portal moment of inertia,

Oscillatory system of bucket wheel drive system [19] is represented as two rotating masses (Fig. 4b).

J_I – electric motor moment of inertia.
 J_{II} – bucket wheel and bucket wheel drive system gearbox moment of inertia.

Solving the system of differential equations using Runge-Kutta methods in Matlab software package –

SIMULINK module (Fig. 5) the results are obtained that will be graphically represented.

Fig. 6 graphically presents vertical movement of bucket wheel time functions that superimposed their own supporting structure vibrations and vibrations caused by the digging force influence.

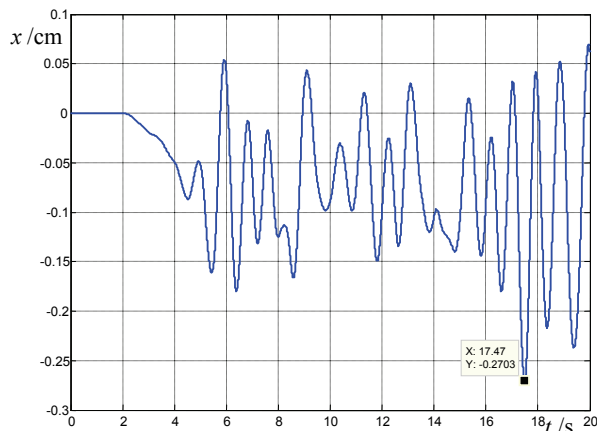

Figure 6 Vertical movement of bucket wheel

The length of a bucket cutting contour changes according to the bucket wheel vertical movement.

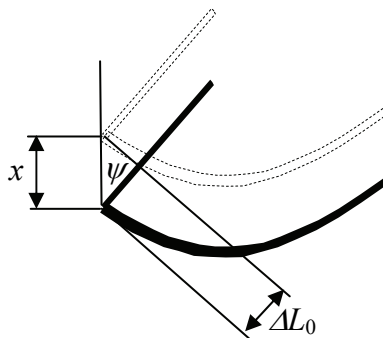

Figure 7 Changing bucket cutting contour

$$\Delta L_0 = 2 \cdot x(t) \cdot \cos \psi, \tag{7}$$

ψ - bucket position angle, $0 \leq \psi \leq \alpha$.

Realistically observed amplitude vibration of bucket wheel in vertical plane does not exceed a few centimetres, which also causes slight changes of cutting force (6 ÷ 7 %). However, when digging in inhomogeneous areas there are large changes in intensity and frequency of digging force. This causes the excessive vibration of bucket wheel in the vertical plane and a significant departure from the bucket cutting contours ideal path.

The sum of buckets cutting contours length (2a) and its calculated changes (7) gives the time function of actual buckets cutting contours length (Fig.7).

$$L_r = L_{tot} + 2x(t) \sum_{i=0}^n \cos \left(\psi + \frac{2i\pi}{z} \right) \tag{8}$$

n – number of buckets that are simultaneously in mesh with the Soil,

z – total number of buckets on bucket wheel,

α – total cutting angle.

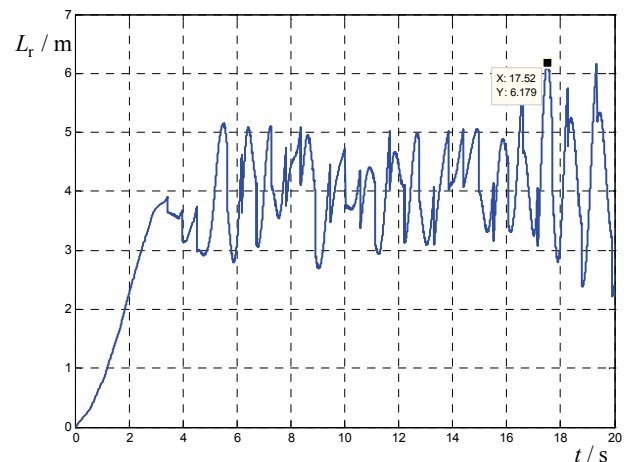

Figure 7 Actual buckets cutting contours length

Based on the measured values of the resistance coefficient and actual length of the cutting contours for buckets that are simultaneously in mesh with the Soil, according to the formula (2), the digging force is calculated and presented graphically in Fig. 8 (blue curve).

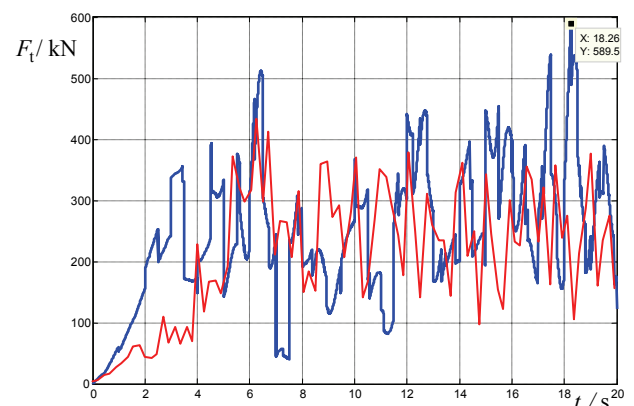

Figure 8 Digging force: blue curve – considering bucket wheel vertical vibration, red curve – excluding bucket wheel vertical vibration

The red curve (Fig. 8) represents digging force where bucket wheel vertical vibration was not taken into account. There is a significant difference in the oscillation frequency and amplitude of the digging forces for these two cases. Namely, the maximum value of digging force has increased by 70 % considering bucket wheel vertical vibration. Oscillations are more frequent which also results in higher dynamic load of bucket wheel drive system.

4 Conclusion

Vibration of bucket wheel in a vertical plane, especially for hard materials excavation, had significant affect on the section geometry and digging force. Therefore, the dynamic calculations of the major BWE sub-systems should not ignore the vibration of bucket wheel in vertical plane. Reconstruction of the BWE sub-

systems main elements pointed to dampening the vibration of bucket wheel in a vertical plane and reducing the digging force would lead to a reduction in their dynamic load. The mathematical model described in this paper can be used to test the effects of BWE sub-systems reconstruction in terms of their dynamic behaviour.

5

References

- [1] Hitzschke, K. Experimentelle Analyse der Belastung des Schaufelrades durch den Grabvorgang, Hebezeuge u. Fördermittel, 1984, H.9
- [2] Bošnjak, S.; Zrnić, N.; Oguamanam, D. On the dynamic modeling of bucket wheel excavators. // FME Transactions 34, (2006), pp. 221-226.
- [3] Volkov, D. P.; Čerkasov, V. A. Dynamics and strength of excavators, translated from the Russian, Department of Mining Institute for Informatics and Economics, Beograd, 1989.
- [4] Raaz, V. Assessment of the Digging Force and Optimum Selection of the Mechanical and Operational Parameters of Bucket Wheel Excavators for Mining of Overburden, Coal and Partings, Krupp Fördertechnik, Esen, 1999.
- [5] Dombrovski, N. G. Multi-bucket excavators: theory, construction, calculation, (In Russian), Mashinostroenie, 1972.
- [6] Rasper, L. Der Schaufelradbagger als Gewinnungsgerät. // Trans Tech Publications, 1973.
- [7] Ljamić, D.; Arsić, M.; Ćirković, B. Experimental analysis of BWE SchRs 650/5×24 bucket wheel load, Mining Machinery - scientific Meeting, Beograd, 1995.
- [8] Gnilke, M. Intelligent retrofit solutions for bucket wheel excavators, MAN TAKRAF Fördertechnik GmbH, Lauchhammer, 2006
- [9] Jevtić, V. Theoretical and experimental studies of flow stresses in lifting subsystem structural elements, master's thesis, Niš-Bochum, 1979.
- [10] Ignjatović, D.; Ristović, I.; Stojković, M. The methodology of the selection of auxiliary mechanisation for the open pit mines of lignite, Mine planning and equipment selection. a.a. Balkema, (2000), pp. 577-581.
- [11] Hedrih (Stevanović), K.; Raičević, V.; Jović, S. Phase Trajectory Portrait of the Vibro-impact Forced Dynamics of Two Mass Particles along Rough Circle. // Communications in Nonlinear Science and Numerical Simulation, ISSN: 1007-5704, 16, 12(2011), pp. 4745-4755.
- [12] Bošnjak, S.; Zrnić, N.; Petković, Z. Bucket wheel excavators and trenchers - Computer added calculation of loads caused by resistance to excavation. // Machine Design, University of Novi Sad, 2006, pp.121-128.
- [13] Gottvald, J. The calculation and measurement of the natural frequencies of the bucket wheel excavator SchRs 1320/4×30. // Transport, 25, 3(2010), pp. 269-277, ISSN 1648-4142 print / ISSN 1648-3480 online, doi: 10.3846 / transport.2010.33,
- [14] Milčić, D.; Miladinović, S. Calculation of the structural elements of the bucket wheel excavator working wheel transmission, UDC621.879. 48:62-233.3
- [15] Daničić, D.; Maneski, T.; Ignjatović, D. Structural diagnostics and behaviour of bucket wheel excavator. // Structural Integrity and Life, 10, 1(2010), pp. 53-59, UDC 620.17:669 539.4.012.
- [16] Jovančić, P.; Ignjatović, D.; Maneski, T. Behaviour Diagnostics of Drive Units on Bucket Wheel Excavators. // Journal of Mechanical Engineering Design, 10, 1(2007), pp. 33-41.
- [17] Luft, M. PRÜFTECHNIK, Online vibration diagnosis and load monitoring on bucket-wheel excavators. // Telediagnose, No 6 – April 2004,
- [18] Jevtić, V.; Golubović, Z.; Lekić, Z. Mathematical modeling of resistance moment as the basic component for the dynamic behavior of the BWE, XIV international conference on material handling and warehousing, Belgrade, 1996.
- [19] Jevtić, V.; Golubović, Z.; Lekić, Z.; Makragić, S. The analysis of dynamic processes in the BWE working wheel drive system with a hydrodynamic coupling, 6th Sever symposium on mechanical gears, Subotica, 1997, pp. 179-185.
- [20] Golubović, Z.; Jevtić, V.; Lekić, Z. Dynamic behavior of planetary gear in BWE drive systems, Yugoslav Congress of Theoretical and Applied Mechanics 97 XXII, Vrnjačka Banja, 2-7 June 1997.
- [21] Golubović, Z. Contribution of drive system reconstruction feasibility for middle class BWE, master's thesis, Kosovska Mitrovica, 2009.

Authors' addresses

mr. sc. Zoran Golubović, dipl. ing.
Faculty of Technical Science
University of Pristina
Knjaza Milosa bb
SRB-38220, Kosovska Mitrovica
E-mail: zoran@vgn.rs

prof. dr. sc. Zlatibor Lekić, dipl. ing.
Faculty of Technical Science
University of Pristina
Knjaza Milosa bb
SRB-38220, Kosovska Mitrovica
E-mail: zlatibor.lekic@gmail.com

doc. dr. sc. Srdjan Jović, dipl. ing.
Faculty of Technical Science
University of Pristina
Knjaza Milosa bb
SRB-38220, Kosovska Mitrovica
E-mail: jovic003@gmail.com