

EMBEDDED CONTROL SYSTEM FOR AUTAREP - A NOVEL AUTONOMOUS ARTICULATED ROBOTIC EDUCATIONAL PLATFORM

Usama Iqbal, Abdul Samad, Zainab Nissa, Jamshed Iqbal

Original scientific paper

This research introduces an open-source framework, AUTonomous Articulated Robotic Educational Platform (AUTAREP). The platform is centred on a 6 Degree Of Freedom (DOF) arm with multiple feedbacks to ensure precision and autonomy. The sensory system consists of vision, position and force feedbacks while the actuation system comprises six precise DC servo motors. In particular, this paper presents the design of an embedded controller for AUTAREP. The proposed design of the control hardware and software interface has been tailored as per academic requirements of relevant undergraduate and postgraduate courses. Low level commands have been provided to permit readily development of applications for trainees. Advanced users can further exploit the open-source architecture of the platform. The performance of the proposed control system has been demonstrated by various experiments on the fabricated hardware. The control has been subjected to various test inputs to analyse its transient and steady state behaviour. The robot has been tested to achieve a set-point position successfully and the encoder data corresponding to all the joints has been recorded. Finally, a common application of "pick and place" has been implemented. The proposed platform is potentially beneficial in teaching engineering courses, training in industrial sector and research of advanced algorithms.

Keywords: control design, educational robot, manipulator, robot control

Ugrađeni upravljački sustav za AUTAREP- novu AUTonomnu Artikuliranu Robotic Edukativnu Platformu

Izvorni znanstveni članak

U ovom se istraživanju predstavlja nova AUTonomna Artikulirana Robotic Edukativna Platforma (AUTAREP). Platforma je usmjerena na ruku s 6 stupnjeva slobode s višestrukom povratnom spregom za osiguranje točnosti i autonomije. Osjetilni se sustav sastoji od povratne sprege za vid, položaj i snagu dok pogonski sustav uključuje šest preciznih DC servo motora. U radu je posebno prikazan nacrt ugrađenog upravljača za AUTAREP. Predloženi nacrt upravljačkog sučelja hardvera i softvera izrađen je prema akademskim potrebama relevantnih prijediplomskih i poslijediplomskih kolegija. Komande nižeg nivoa pružaju mogućnost razvoja aplikacija za one koji se obučavaju. Napredni korisnici mogu dalje istraživati otvorene mogućnosti arhitekture platforme. Rad predloženog upravljačkog sustava prikazan je različitim eksperimentima na proizvedenom hardveru. Upravljanje je bilo podvrgnuto različitim vrstama ispitivanja u svrhu analiziranja ponašanja u prijelaznom i stacionarnom stanju. Robot je ispitivan kako bi se uspješno postigao zadani položaj te su zabilježeni podaci kodera koji odgovaraju svim zglobovima. Konačno, provedena je uobičajena aplikacija "uzmi i postavi". Predložena platforma može biti korisna u nastavi tehničkih kolegija, obučavanju u industrijskom sektoru i istraživanju naprednih algoritama.

Ključne riječi: edukacijski robot, manipulator, projekt komandi, upravljanje robotom

1 Introduction

Emerging trends in Mechatronics are transforming human life into robotics era. The diversity in robotics applications, especially that of industrial robots, is on constant increase, ranging from food to pharmaceuticals, electronics to automobile industry [1] and simple to sophisticated operations e.g. in nuclear power plants [2]. This remarkable growth of robot applications in various sectors has necessitated the updating of engineering curriculum. The need of the hour in technical education is to deliver theoretical concepts through practical approach. Especially, in a multi-disciplinary area like robotics, sophisticated platforms with the ability to practically demonstrate the concepts from various engineering domains are highly demanded. Scientific literature reports numerous robotic platforms developed specifically for educational purposes. Quite a large number of these platforms [3 ÷ 6] are based on mobile robots. Besides, there are generic frameworks that can be used to develop multi-configuration robots for educational purpose e.g. Lego [7], RoboRobot kits, Meccano Robot, etc. These generic platforms may not fulfil the desired performance requirements and applicability in case of articulated based multi-Degree of Freedom (DOF) arms. Despite the fact that the first robots were programmable multifunctional manipulators for industry, only a few training systems based on robotic arms have been addressed [8]. Broadly categorizing, these include virtual frameworks and

platforms employing a real robotic arm.

Most of the reported articulated platforms are limited just to simulation. These virtual robotic systems e.g. [9], exploiting the integration of engineering software and graphical tools, provide cost-effective solutions with multiple illustrations and offer fascinating pictures of robotic systems. They are unbreakable and offer creation of multiple instances of robots without any cost. However, these 'soft' tools essentially suffer from various drawbacks: they may not be able to completely and correctly specify in-depth performance corresponding to a real robot; practical limitations on actuators and force/torque transmission mechanisms can affect the specifications and stability of the virtual model controller; virtual models do not usually address the non-linearities associated with the physical systems; and the accuracy and credibility of the results obtained in a simulated environment, in many cases, are not comparable with the results of real experiments. Furthermore, the students do not acquire the same exposure, foundation, confidence and excitement while working on simulated robots as compared with their physical counterparts.

Educational platforms employing a real robotic arm [10 ÷ 13] can be counted on fingertips. Some of these platforms suffer from limitations in terms of flexibility, scalability and modularity while others lack financial affordability or have fewer DOFs. Also, availability of limited commands or functions in the platforms' proprietary instruction sets put a constraint on the type of

control algorithms and strategies that can be implemented. In most of the mentioned platforms, there is no provision of an interface to re-program the controller by downloading the code into its flash. Lack of vision feedback and unavailability of force or tactile sensors in these platforms further limits the radius of activities that should be performed for students training. So, there is a deficiency of a flexible and open-source platform for teaching and training on articulated based robotic arms that can facilitate robotics for their successful entry into the robotic industry.

The rest of the paper is organized as follows: Section 2 discusses novelty and specifications of AUTAREP. Kinematic model of the robot is described in Section 3. The custom-developed hardware and software are detailed in Sections 4 and 5 respectively. Results of experiments on AUTAREP prototype are presented in Section 6. Finally, Section 7 comments on conclusion and highlights the applications of the proposed platform.

2 AUTAREP: novelty and specifications

AUTAREP is a novel framework that presents the following features in the form of an educational robotic system:

- DOF: 6 (all active)
- Autonomy: Offered by an on-board camera.
- Control strategies: Position as well as force control.
- Open-source: The developed commands library, software interface, hardware schematics, source code, part-lists are freely available on request.
- Design theme: Highly modular and inherently flexible design.
- Applications: Academics, educational and industrial use.

The overall system of AUTAREP mainly consists of a 6 DOF robotic arm manipulator, a controller with drive mechanism, teach pendant and a dedicated PC/Laptop. Fig. 1 shows AUTAREP in operation.

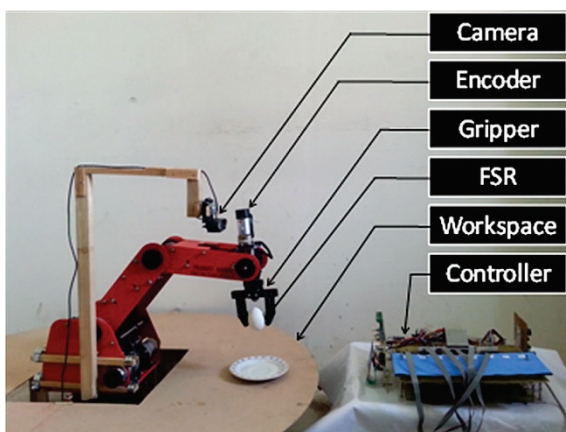

Figure 1 AUTAREP in operation

AUTAREP combines robot modelling and control features with image-processing to perform desired operations. In a typical task execution, the whole workspace is scanned and corresponding images are captured. These images are processed to acquire the coordinates of the target object(s). On the basis of these

coordinates, the developed Inverse Kinematic (IK) model of the arm computes the required joint angles. If the resultant joint angles remain in the Range of Motion (ROM) of the arm, they are mapped to the low-level encoder ticks. Based on the computed ticks, the motors are finally actuated to execute the command. Important specifications of the platform are listed in Tab. 1.

Table 1 AUTAREP specifications

Parameters	Specs.	Description
Kinematics	No. of joints	5
	No. of DOF	6
	Range of Motion (ROM)	Wrist pitch: 260° Wrist roll: 360° Elbow: 172° Shoulder: 90° Waist: 310°
Physical	Locomotion	Articulated links
	Actuation	6 DC Servo motors
	Weight	33 Kg
	Dimensions	Base $\varnothing 220 \times 180(H)$ mm Arm length 220+220 mm
Sensing	Vision	Camera (Logitech)
	Force	FSR attached at Gripper
	Position	Optical encoders
Performance	Position precision	$\pm 1,5$ mm
	Position repeatability	± 1 mm
	Movement speed	100 mm/s (max.)
	Payload	1 kg
	Action radius	580 mm (largest)

3 Robot kinematic model

For a robotic arm, to execute a certain task, the solution of positioning problem needs to be evaluated. This essentially demands transformation between the end-effector configuration and joint-space variables. Thus the kinematic model involves derivation of Forward as well as IK.

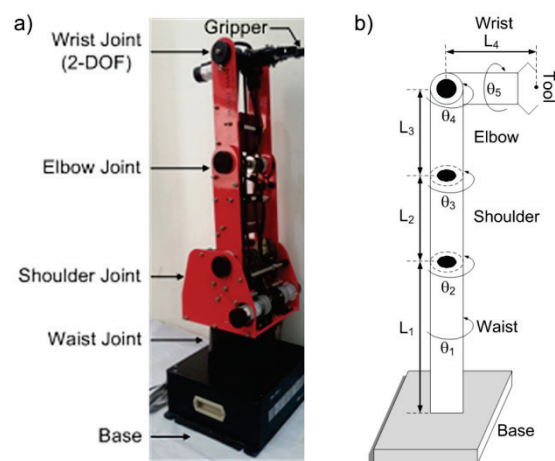

Figure 2 Robot in AUTAREP: (a) Arm showing various joints (b) Kinematic representation

In the present work, Denavit-Hartenberg (DH) method has been used to develop the kinematic model of the robot because of its versatility and acceptability for modelling any number of joints and links of a serial manipulator regardless of complexity. DH works with

quadruple $\{\alpha_{i-1}, a_{i-1}, d_i, \theta_i\}$ which represents twist angle, link length, link offset and joint angle respectively. Following DH convention, an orthonormal coordinate system has been attached to each link of the manipulator. Fig. 2a shows the robot while the simplified kinematic model of the robot is illustrated in Fig. 2b.

Tab. 2 lists DH parameters for the robotic arm used in AUTAREP [14].

Table 2 DH Parameters of Robotic Arm

Symbol	Joints (<i>i</i>)					
	1	2	3	4	5	6
α_{i-1}	0	-90°	0	0	-90°	0
a_{i-1}	0	0	L_2	L_3	0	0
d_i	L_1	0	0	0	0	L_4
θ_i	θ_1	$\theta_2 - 90^\circ$	θ_3	θ_4	θ_5	0

Based on these parameters, the overall transformation matrix from end-effector frame {6} to base frame {0} is

$${}^0T = \begin{bmatrix} C_1 C_5 S_{234} + S_1 S_5 & -C_1 S_5 S_{234} + S_1 C_5 & C_1 C_{234} & C_1 A \\ -S_1 C_5 S_{234} - C_1 S_5 & S_1 S_5 S_{234} + C_1 C_5 & S_1 C_{234} & S_1 A \\ C_{234} C_5 & -C_{234} S_5 & -S_{234} & B \\ 0 & 0 & 0 & 1 \end{bmatrix}, \quad (1)$$

where

$$A = L_2 S_2 + L_3 S_{23} + L_4 C_{234}, \quad (2)$$

$$B = L_1 + L_2 C_2 + L_3 C_{23} - L_4 S_{234}. \quad (3)$$

The IK model of a robot, on the other hand, provides the joint angles in correspondence with the given position and orientation of the end-effector. The IK of the AUTAREP arm has been derived in [14] using analytical and geometrical techniques. Analytical approach computes equations for the first three joints including waist (θ_1), shoulder (θ_2) and elbow (θ_3) while the tool pitch angle (θ_4) has been calculated using geometrical method. The last angle θ_5 (tool roll) is directly dictated by the object manipulation requirements [15].

Application development based on an articulated platform essentially requires knowledge of the robot’s workspace. Using link lengths and ROM information of each joint of the AUTAREP robotic arm (Tab. 1), the arm workspace has been mathematically found from Eq. (1 ÷ 3). The work envelope, spherical in shape, demonstrates that the robot can manipulate the objects lying within radius of 580 mm.

4 Embedded controller design

Design of the proposed embedded controller is primarily centred on a high performance 16-bit digital signal controller dsPIC33F. Each motor of the robot is equipped with a differential optical encoder to provide direction and position feedback to the microcontroller. The controller accepts and executes user commands from either GUI running on a PC or through a teaching pendant. The interface between the PC and the controller is through COM port while teaching pendant is connected to digital inputs of the embedded controller. Fig. 3 presents the block diagram of the proposed hardware where a single motor driver and a DC servo motor with

optical encoder are shown. The complete system replicates these two components for six motors, however, controlled by a single controller.

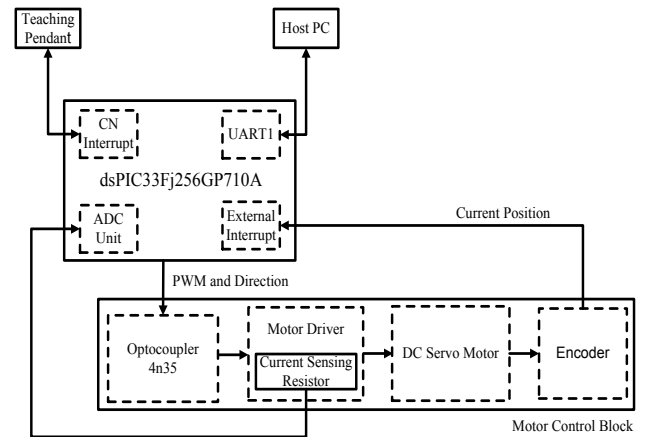
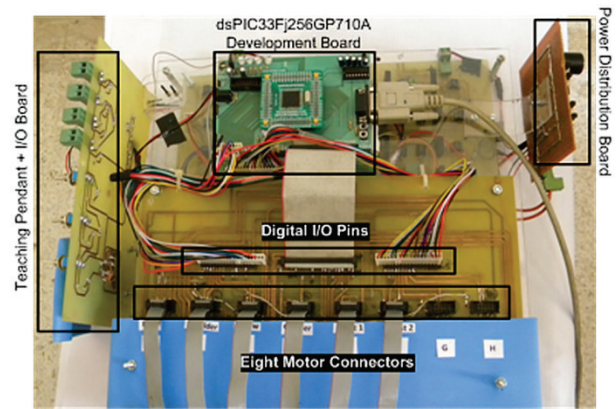
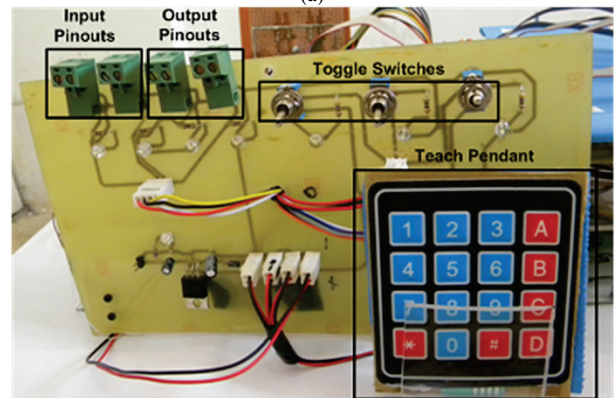

Figure 3 Block diagram of embedded hardware for position control



(a)



(b)

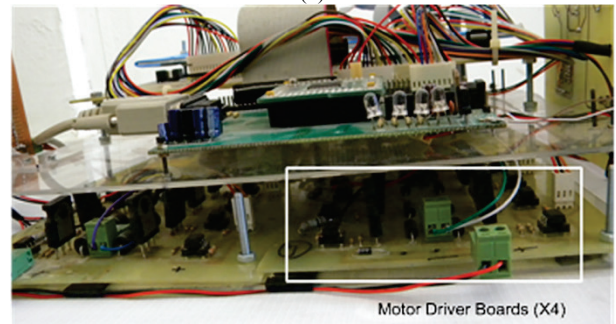

(c)

Figure 4 Fabricated hardware (a) Top view (b) Front view (c) Side view

The central controller manipulates and controls the functionality of all the six motors of the robotic arm. The

16-bit timer module generates appropriate Pulse Width Modulation (PWMs) signals to drive the motors at desired speed. External devices can be interfaced with the controller using available Change Notification (CN) interrupt pins. To avoid damage to the robot structure in case of stall condition, current sensing resistors have been added to each of the motor driver to limit the current supply. The current is sensed by internal Analog to Digital Converter (ADC) unit of the controller. E²PROM of the controller holds the current and home positions of all motors and controller parameters. DC servo motors (DME38B50G-115) that draw 0,65 A current during normal operations and 1,5 A install condition are being used in the robotic arm. This rating guided the custom design of the motor drivers that use BJTs for switching.

Fig. 4 illustrates three different views of the fabricated hardware. Fig. 4a shows the top view where the dsPIC controller and eight motor headers are visible. The board provides facility to interface two additional motors with the controller. The front view of the hardware (Fig. 4b) shows the teaching pendant and I/O interface for external devices. Custom developed motor drivers can be seen in the side view (Fig. 4c).

AUTAREP offers testing and validation of position control strategies as well as force control algorithms. The later feature is attained by adding a Force Sensing Resistor (FSR) and associated circuitry. With this additional feature, the gripper is able to grasp both soft and sturdy objects without exerting unnecessary force on the object.

5 Embedded control system software

AUTAREP is a ‘ready to go’ framework with low level kernel commands that offer readily development of applications. These commands have been grouped into four categories according to their functionalities. The commands have been designed so that users can directly use them in their applications to exploit full features of the embedded controller and the robotic manipulator. The developed commands are listed in Tab. 3.

Table 3 Commands Summary

Category	Command	Description
Motor read commands	GS	Read gripper status
	HR,m	Read soft home position
	PA,m	Read actual position
	PW,m	Read destination position
	RL	Read limit switches
Gain commands	KA,m,d	Set proportional gain
	KB,m,d	Set differential gain
	KC,m,d	Set integral gain
	RA,m	Read Proportional gain
	RB,m	Read differential gain
Input /Output commands	IB,b	Read input or switch bit
	IP	Read input port
	IX	Read switch port
	OB,b,s	Set output port
	OP,d	Set output port
	OR	Read output port
	OT,b,s	Toggle output bit
Motor set commands	AC,m	Clear motor actual position
	GC	Close gripper
	GO	Open gripper
	HA	Go to hard home position
	HG	Go to soft home position
	HH	Execute a hard home
	HL,m	Hard home on limit switch
	HS	Set soft home
	MA	Stop all motors
	MC	Start all motors coordinated
	MI	Start all motors independently
	MM,m	Stop single motor
	MS,m	Start single motor
	PD,m,d	Set motor destination position, absolute
	PR,m,d	Set motor destination position, relative

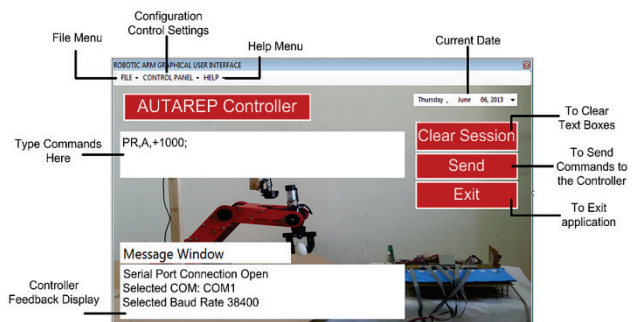

Figure 5 Developed GUI for controlling AUTAREP

A user-friendly software interface has been designed to facilitate Human Robot Interaction (HRI) through the command-set. The custom-developed GUI is based on features like dialog boxes, prompt messages, menus and icons and is interactable through a keyboard and a mouse. The elements in the GUI are intuitive and are manipulated directly, resulting in the execution of corresponding actions. Fig. 5 illustrates the main GUI window.

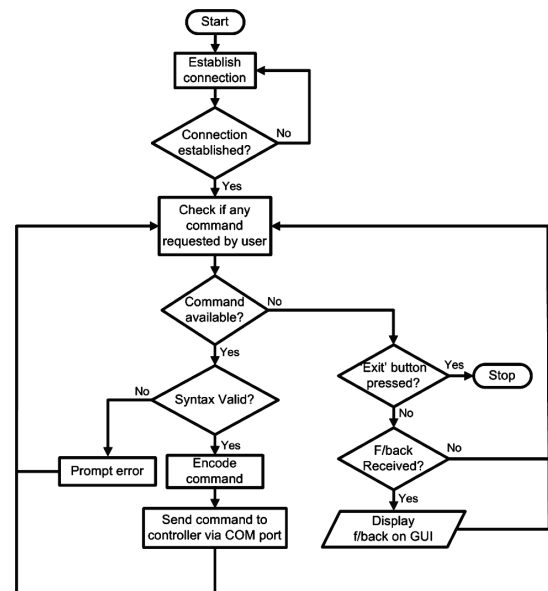

Figure 6 Flowchart of GUI functionality

After initialization, certain parameters are configured in the application program’s Dynamic Link Libraries. These parameters include selection of COM port and baud rate setting for serial communication. After establishing the connection through COM port, the program enters into the listening mode and waits for the user’s commands. The commands are typed in the command box and send button is pressed to process the command. Feedbacks from the controller as well as other messages

are displayed in the message window. A simplified flow chart of GUI functionality is presented in Fig. 6.

Depending on the category of commands (Tab. 3), the execution logic performs appropriate actions. The algorithm waits for a command sent by the user either from the developed GUI running on a PC through serial interface or through the teaching pendant directly connected to the digital inputs of the controller. The command once encountered, is first checked for its valid syntax by the GUI. The user is prompted for wrong command syntax and/or missing parameters. Consider a typical command of ‘motor move’ having a valid syntax to be executed by a controller (say PID). The command is sent to the microcontroller where it is decoded and information is extracted from it. The desired position and direction are then commanded to the PID control loop. Based on the encoder data as position feedback, the closed loop PID controller with the tuned gains ensures that the desired position is achieved. When the motor has achieved the desired position, the control loop terminates and the controller waits to receive subsequent commands from the user. Fig. 7 shows the flowchart of the command execution.

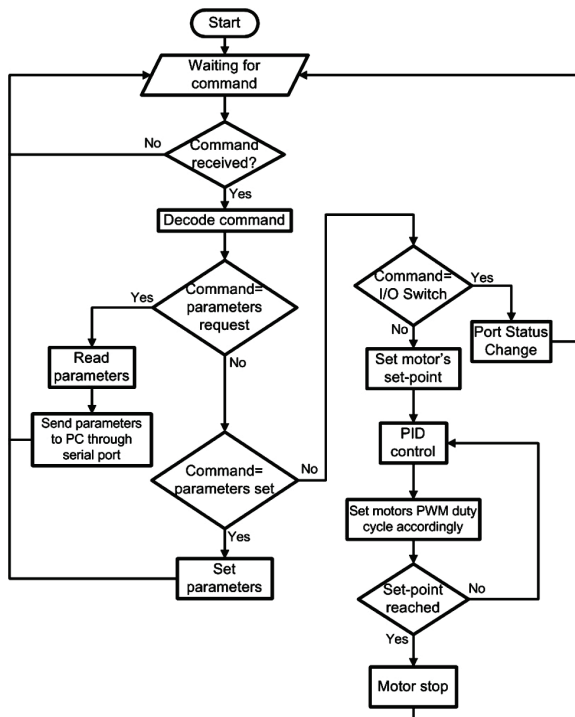

Figure 7 Flow chart of the controller executing user commands

Though implementation of a trivial algorithm like PID has been mentioned in this paper graduate and post-graduate students can implement more sophisticated control algorithms by exploiting open hardware and software architectures of AUTAREP.

6 Experimental results

The proposed embedded controller for AUTAREP has been subjected to various test inputs to study and analyse the response. These inputs include step, ramp, sinusoidal etc. Encoder data corresponding to the position of each joint of the robotic arm has been recorded. Results for some of the joints are presented in Figs. 8 ÷ 10. The

dashed lines show the desired positions while solid lines indicate the measured position (encoder data).

In case of step input, the arm joints have been subjected to step of 10°. Fig. 8 shows the corresponding response for the wrist pitch joint. The settling time has been found to be less than 0,3 s while the % age overshoot did not exceed 5 %. To observe the ramp response, ramp inputs of slopes varying from 30 to 50 °/s have been given to the control system. Fig. 9 shows the corresponding result for the elbow joint. The system takes 0,4 s (at max.) to reach the desired trajectory and then it follows the reference exactly. To analyse the behaviour of the control system in response to a sinusoidal input, a sin wave of frequency 0,16 Hz has been given to the base joint while the remaining joints are subjected to 0,8 Hz sinusoidal. Below the specified frequencies, the system is able to track the reference trajectory almost exactly. The encoder data for several cycles of sinusoidal reference has been recorded. Fig. 10 shows the corresponding results in case of shoulder joint. Results demonstrate a consistent behaviour throughout several sinusoidal cycles.

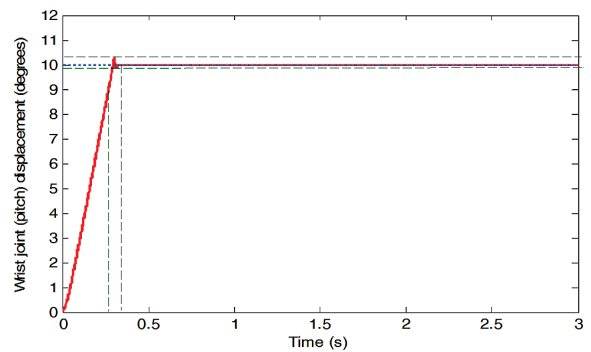

Figure 8 Step response of Wrist pitch joint

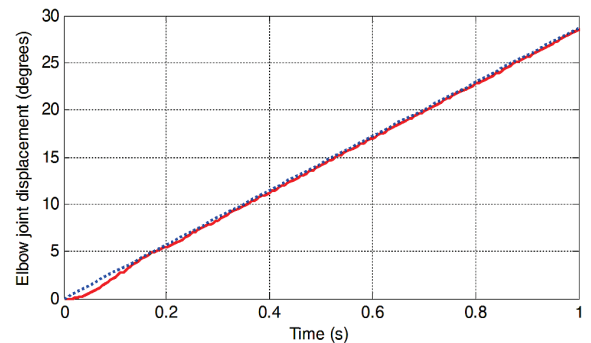

Figure 9 Ramp response of Elbow joint

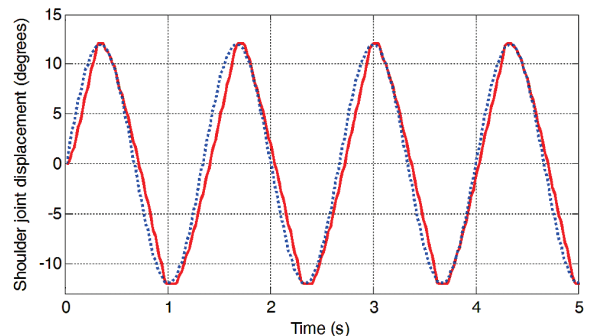

Figure 10 Sinusoidal response of Shoulder joint

To observe the movement of all the joints simultaneously, the manipulator has been moved to an

arbitrary position and then commanded to go to its home position. Fig. 11a shows the trajectories of various joints during this experiment. Once the robot reaches its home position, the encoder data corresponding to all the joints is zero as shown in the Fig. 11. The robot is then commanded to move to the pre-defined set-points. The trajectories followed by each joint to reach that position have been presented in Fig. 11b.

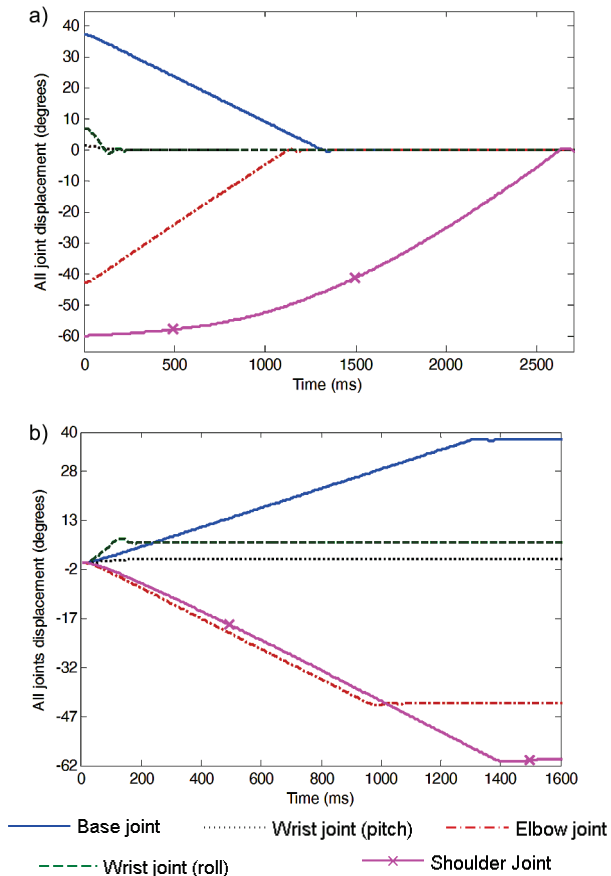

Figure 11 Encoder data of all the joints corresponding to the robot commanded to move to (a) its home position (b) a set-point position

Finally, we have considered a more practical application of AUTAREP i.e. pick and place task during

objects sorting. An object has been autonomously picked up following the sequence mentioned in Section 2 and placed at the user-selected location. The trajectories followed by various joints of the robot are shown in Fig. 12. The task accomplishment has been divided into time intervals (T_1 to T_5) according to the manipulator's activity. These intervals are explained below:

- T_1 : Moving to pick the object
- T_2 : Gripper closed (object picked-up)
- T_3 : Moving towards destination position
- T_4 : Gripper open (object dropped)
- T_5 : Moving towards home position.

In addition to the position feedback from encoders, force data from FSR mounted at the inner side of the robot gripper permits manipulation of hard as well as soft objects. Fig. 13 illustrates two such cases where the arm has been commanded to pick and place an egg (Fig.13a) and an iron rod (Fig. 13b). In this typical case, the measured force levels, required to manipulate soft objects, are approximately half of the corresponding levels for sturdy object.

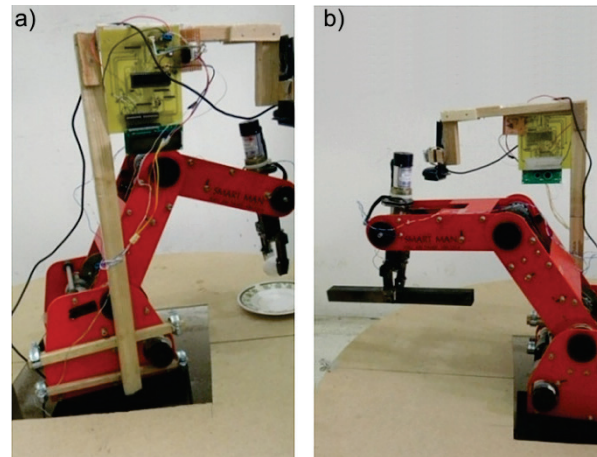

Figure 13 Platform interacting with a (a) Fragile object (b) Sturdy object

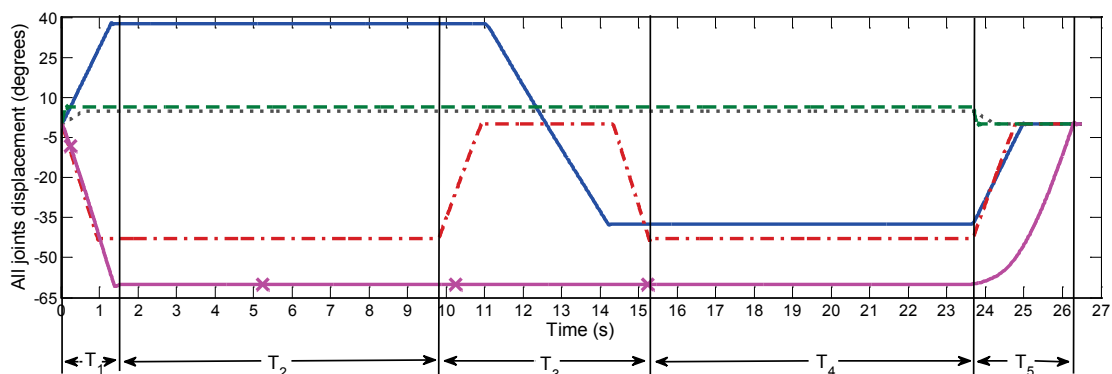

Figure 12 Encoder data of all the joints corresponding to pick and place task accomplishment

7 Conclusion

An articulated robotic educational framework has been presented with a focus on its embedded control

system. The performance of AUTAREP control system has been presented during the pilot study based on series of experiments conducted on AUTAREP prototype. These experiments have exhibited that nearly every

possible motion trajectory can be followed with adequate accuracy. The efficacy of the platform has been demonstrated by implementing autonomous pick and place task.

AUTAREP is an open-source framework, thus making it an attractive choice for academic and research community by skipping licensing costs and shortening the development time. To extend the platform, a number of possibilities are envisaged. It is straight-forward to widen the scope of AUTAREP by simply inserting other tools in the robot's gripper like paint brush, welding gun, drill, grinding wheel, etc. Two major avenues are open for near future: one is to replace the existing two-state gripper with a complete five-fingered robotic hand to make the platform dexterous and ergonomic, while the other avenue is to make the platform mobile by mounting it on a wheel-based robot having its own dedicated controller and electronics. Implementing such enhancements, we believe that the platform will become an ultimate resource tool for education and training of robotics and technology. Even in its current state, the platform has a huge potential to be used in teaching various courses like Control, Robotics, Image-processing, Computer vision, etc. In addition to regular laboratory exercises, AUTAREP is a piece of art for students to implement and investigate their projects. The three on-going R&D projects on AUTAREP, worth to be mentioned, include implementation of control algorithms reported in [16], object manipulation using brain HRI [17] and robot control based on voice commands.

AUTAREP, being a mini-industrial robotic system, can also be used in an industrial environment to train interneers and to test various strategies prior to their execution on actual manipulators. In addition to teaching and training purposes, the platform has the potential to open avenues of research for advanced algorithms like object manipulation and grasping, trajectory generation and path planning, etc.

8 References

- [1] Isak, K.; Edina, K.; Ermin, H. Industrial robot applications in manufacturing process in Asia and Australia. // Tehnicki vjesnik-Technical Gazette. 20, 2(2013), pp. 365-370.
- [2] Sébastien, V.; Nazih, M.; Alain, R.; Ameziane, A. Design of a novel long-range inflatable robotic arm: Manufacturing and numerical evaluation of the joints and actuation. // ASME Journal of Mechanisms and Robotics. 5, 4(2013).
- [3] Iqbal, J.; Nabi, R.; Khan, A. A.; Khan, H. A novel track-drive mobile robotic framework for conducting projects on robotics and control systems. // Life Sci J. 10, 3(2013), pp. 130-137.
- [4] Gonzalez, G. J.; Valero, G. A.; Prieto, M. A.; Abderrahim, M. A new open source 3D-printable mobile robotic platform for education. U. Rückert, S. Joaquin and W. Felix (eds.), Advances in Autonomous Mini Robots. Springer, 2012.
- [5] Su, J. H.; Lee, C. S.; Huang, H. H.; Huang, J. Y. A micromouse kit for teaching autonomous mobile robots. // Int. J. Elect. Eng. Educ. 48, 2(2011), pp. 188-201.
- [6] Magnenat, S.; Riedo, F.; Bonani, M.; Mondada, F. A programming workshop using the robot "Thymio II": The effect on the understanding by children. // IEEE Workshop on Advanced Robotics and its Social Impacts (ARSO), 2012, pp. 24-29.

- [7] Burbaite, R.; Stuiyks, V.; Marcinkevicius, R. The LEGO NXT robot-based e-learning environment to teach computer science topics. // Elektronikai Elektrotechnika (Electronics and Electrical Engineering) Kaunas Technologija. 18, 9(2012), pp. 113-116.
- [8] Prosevcicius, T.; Bukis, A.; Raudonis, V.; Eidukeviciute, M. Hierarchical control approach for autonomous mobile robots. Elektronikai Elektrotechnika (Electronics and Electrical Engineering) Kaunas Technologija. 4, 110(2012), pp. 101-104.
- [9] Kumar, R.; Kalra, P.; Prakash, N. R. A virtual RV-M1 robot system. // Robotics and Computer-Integrated Manufacturing. 27, 6(2011), pp. 994-1000.
- [10] OWI-535 robotic arm edge, OWI arm trainer robot kit, <http://www.robotshop.com/owi-535-robotic-arm-edge-4.html>, (11-9-2013).
- [11] AL5D robotic arm specification sheet, Lynxmotion Inc., <http://www.lynxmotion.com/c-130-al5d.aspx>, (11-9-2013).
- [12] "Model XR-4. A semi-enclosed, advanced design, five axis, robot arm with electrical gripper", Rhino Robotics Ltd., Ohio, USA, http://www.rhinorobotics.com/xr4_flyer.html, (11-9-2013).
- [13] SCORBOT-ER 4u user manual, Catalog no. 100343 Rev. B, Intelitek, http://intelitek.com/ProductDetails.asp?Product_ID=17&CategoryID=3&Industrial=&Education=yes&category_str_id=3, (11-9-2013).
- [14] Iqbal, J.; Islam, R.; Khan, H. Modeling and analysis of a 6 DOF robotic arm manipulator. // Canadian Journal on Electrical and Electronics Engineering. 3, 6(2012), pp. 300-306.
- [15] Islam, R.; Iqbal, J.; Manzoor, S.; Khalid, A.; Khan, S. An autonomous image-guided robotic system simulating industrial applications. // Proceedings of the IEEE International Conference on System of Systems Engineering (SoSE), Italy, 2012, pp. 338-343.
- [16] Khan, M. F.; Islam, R.; Iqbal, J. Control strategies for robotic manipulators. // Proceedings of the IEEE International Conference on Robotics and Artificial Intelligence (ICRAI), 2012, pp. 26-33.
- [17] Naveed, K.; Iqbal, J.; Rahman, H. U. Brain controlled human robot interface. // Proceedings of the IEEE International Conference on Robotics and Artificial Intelligence (ICRAI), 2012, pp. 55-60.

Authors' addresses

Usama Iqbal, Ing.
Abdul Samad, Ing.
Zainab Nissa, Ing.
Jamshed Iqbal, Asst. Professor Dr. Ing.
 Robotics & Control Research (RCR) Group,
 Department of Electrical Engineering,
 COMSATS Institute of Information Technology (CIIT),
 Park Road, Chak Shahzad,
 Islamabad, Pakistan
 E-mail: jamshed.iqbal@comsats.edu.pk