

## Role of Nitrogen Oxides in Ozone Toxicity

Mitchell Friedman,<sup>a</sup> Saša Kazazić,<sup>b</sup> Nenad Kezele,<sup>b</sup> Leo Klasinc,<sup>b,c,\*</sup>  
Sean P. McGlynn,<sup>c</sup> Snježana Pečur,<sup>b</sup> and William A. Pryor<sup>c,d</sup>

<sup>a</sup> *Tulane University Medical Center, New Orleans, LA 70148, USA*

<sup>b</sup> *Ruđer Bošković Institute, P .O. Box 180, HR 10002 Zagreb, Croatia*

<sup>c</sup> *Chemistry Department, Louisiana State University,  
Baton Rouge, LA 70803, USA*

<sup>d</sup> *Biodynamics Institute, Louisiana State University,  
Baton Rouge, LA 70803, USA*

Received October 20, 1999; revised March 29, 2000; accepted April 5, 2000

The preparation of ozone/nitrogen oxides mixtures in air containing the nitrate radical, their reaction with the unsaturated lipid 1-palmitoyl-2-oleoyl-*sn*-glycero-3-phosphocholine (POPC), and the determination of the reaction products in comparison to those obtained from a reaction with only ozone in air by MALDI-FTMS is described. The results indicate the importance of nitrate radical in ozone toxicity.

*Key words:* dinitrogen pentoxide, nitrate radical, nitrogen dioxide, reaction with lipide(s), mass spectrometry, MALDI.

### INTRODUCTION

Ozone is the most abundant oxidant in polluted air and its adverse effects on human health are well documented.<sup>1</sup> The lung is the organ that is most affected by ozone. Short term exposure to high levels of ozone leads to acute inflammatory reactions and pulmonary edema whereas prolonged ex-

---

\* Author to whom correspondence should be addressed.

posure to lower levels produces emphysema, bronchopneumonia and fibrosis. Numerous studies have established the ability of ozone to react with species present in the lung; they include the amino acids, peptides and proteins.<sup>2,3</sup> However, the primary target of ozone is thought to be the unsaturated fatty acids (UFA) in the fluid layer of the lung lining and in the epithelial cell membranes of the lung.<sup>4-6</sup> Because of its reactivity, ozone does not penetrate far into the cells that line the airways; consequently, many pulmonary and all extrapulmonary effects of ozone must be caused by messenger species. Thus, inhalation of even low ozone concentrations can cause the release of proinflammatory mediators in the lung, and it is these mediators that lead to the inflammation and other effects associated with ozone.

The cascade hypothesis<sup>7</sup> states that lipid ozonation products (LOP) relay the effects of ozone into deeper tissue strata at the lung-air interface than ozone itself can reach. LOP, rather than products from ozonation of proteins or nucleic acids, are thought to be signal transduction species because ozonation of UFA leads to small, diffusible, stable or metastable species, and because lipid oxidation products are known to act as signal transduction agents in other systems. Thus, the likely candidates for signal transduction species are LOP produced in the Criegee ozonation process, which gives a predictable spectrum of products.<sup>8-11</sup> Recent results by Friedman, Pryor and coworkers strongly support this hypothesis.<sup>12-17</sup>

Nitrogen oxides (NO and NO<sub>2</sub>) are usually present in a mixture with other air pollutants in real-life exposures.<sup>18,19</sup> With ozone present, all nitric oxide is converted to nitrogen dioxide. Early studies indicated that the responses to ozone and nitrogen dioxide were additive, but it was also found that the immediate effects in rat lungs were dissimilar with respect to lipid peroxidation, lung protein or nonprotein sulfhydryl levels.<sup>20</sup> Starting in the 1980's, Pryor and coworkers<sup>21-23</sup> investigated the oxidation of biological molecules by nitrogen dioxide. The relatively high tolerance for both long-term and short-term exposure to ambient nitrogen dioxide made it unnecessary to include NO<sub>2</sub> chemistry in the cascade hypothesis of ozone toxicity. However, the combined action of ozone and nitrogen dioxide must take account of the fact that these gases rapidly react to form the nitrate radical, a very potent oxidant. In fact, NO<sub>3</sub> reacts with unsaturated organic molecules more than a thousand times faster than does ozone.<sup>24</sup>

Here we report the preparation of ozone/nitrogen oxides mixtures in air containing the nitrate radical. The reaction of such mixtures is carried out with 1-palmitoyl-2-oleoyl-*sn*-glycero-3-phosphocholine (POPC) applied on a surface and the reaction products are determined by matrix-assisted laser desorption/ionization Fourier transform mass spectrometry (MALDI-FTMS). The results are compared with those obtained from parallel reaction

when only ozone in air was used to react with POPC. POPC was used in this study because it is the most frequently investigated unsaturated lipid molecule what enables reliable comparison with previous results. The optimal conditions for determination the reaction products and elucidation of the synergistic effects of ozone and nitrate radical in the heterogeneous reaction with lipids are determined.

## EXPERIMENTAL

*Reactions.* An apparatus (Figure 1) consisting of an evacuable glass reaction column and mixing chamber, maintained in the dark because of the ready photodegradability of nitrate radical, was used to perform the reactions. The lipid, POPC (Sigma Chemical Co., St Louis, MO), dissolved in dichloromethane and spread inside the reaction column, yielded a thin film after evaporation. The lipid film was allowed to react with the gas mixture from the mixing chamber for a specified time. If necessary to ensure completion of the reaction, the previously reacted thin layer of sample was redissolved and, using the same procedure, was again exposed to the same gas mixture. The gas reaction mixtures were prepared by mixing streams of known concentrations of ozone in pure oxygen with a stream of pure nitrogen, which did or did not contain a known concentration of nitric oxide. The concentrations within the gas streams produced air samples with environmentally-relevant concentrations of ozone and nitrogen dioxide (appr. 100 ppb of each). Thus, in conditions of excess ozone, fast conversion of nitric oxide produced  $O_3/NO_2$  mixtures which, in the dark, react slower to give nitrate radicals. Either ozone/air or (ozone + nitrogen oxides)/air mixtures were allowed to react with the lipid films, and the reaction products of each reaction were compared.

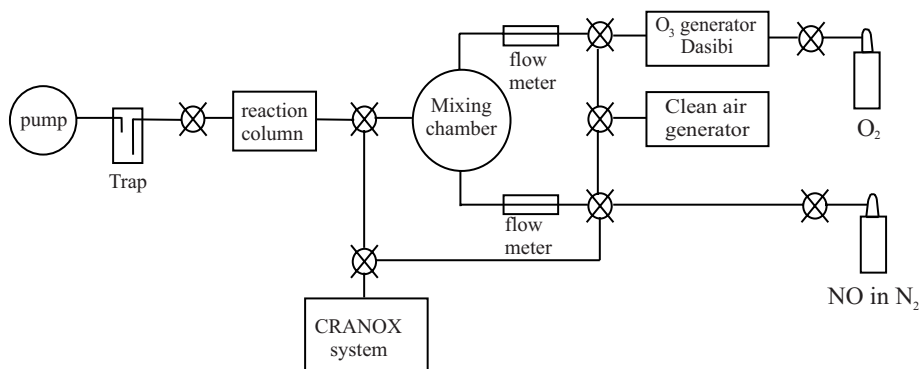

Figure 1. Apparatus for carrying out the reaction of POPC with ozone and ozone/nitric oxide mixtures in air.

*Mass spectra.* Mass spectra were recorded on an FTMS 2001 DD spectrometer (Finnigan FT/MS, Madison, WI, USA) equipped with a 3 T superconducting magnet, and a Nicolet 1280 data station using a pulsed nitrogen laser (VSL-337ND-S, Laser Science, Inc. Franklin, MA, USA) at 337 nm for MALDI experiments. We initially used 2,5-dihydroxybenzoic acid (DHB) as the MALDI matrix. It gave abundant positive and negative fragmentation ions for the POPC and its ozonation products but little or no protonated ( $m/z = 760$ ), sodiated ( $m/z = 782$ ) and ozonated ( $m/z = 808$ ) molecules. To avoid fragmentation we tested unsuccessfully several other matrices (e.g. *p*-nitrobenzoic acid and 3-nitrophenol) and sample probe cooling. Only 3-nitrobenzyl alcohol as a matrix with a cooled sample probe yielded phospholipid ions and mass spectra of their reaction products with little or no fragmentation and formation of alkali metal adduct peaks. All the spectra were collected after a single laser shot.

*Calculations.* Because the rate constants for all the respective reactions are known (Table I) it is possible to calculate development of  $\text{NO}_3$  radical concentration starting with  $\text{O}_3 + \text{NO}$  at room temperature and normal pressure in air. Calculation results for the first 1000 s of 50 ppb NO with 100, 150 and 200 ppb of ozone show final concentrations of 0.11, 0.24 and 0.60 ppb for  $\text{NO}_3$ , and 48, 96 and 141 ppb for ozone, respectively. In these calculations the photoreaction of  $\text{NO}_3$  (dark conditions) and decomposition of ozone (amounting less than 10% for the investigated time period as independently determined) were omitted. The results are shown in Figure 2a–c.

TABLE I

Reactions and their rate constants used in the simulation of product formation from ozone/nitric oxide mixtures in air

Reaction	Rate constants*
$\text{NO} + \text{O}_3 \rightarrow \text{NO}_2 + \text{O}_2$	$1.8 \times 10^{-14} \text{ cm}^3 \text{ molecule}^{-1} \text{ s}^{-1}$
$\text{NO} + \text{NO}_3 \rightarrow 2\text{NO}_2$	$2.6 \times 10^{-11} \text{ cm}^3 \text{ molecule}^{-1} \text{ s}^{-1}$
$\text{NO}_2 + \text{O}_3 \rightarrow \text{NO}_3 + \text{O}_2$	$3.2 \times 10^{-17} \text{ cm}^3 \text{ molecule}^{-1} \text{ s}^{-1}$
$\text{NO}_2 + \text{NO}_3 + \text{M} \rightarrow \text{N}_2\text{O}_5$	$2.0 \times 10^{-12} \text{ cm}^3 \text{ molecule}^{-1} \text{ s}^{-1}$
$\text{N}_2\text{O}_5 + \text{M} \rightarrow \text{NO}_2 + \text{NO}_3 + \text{M}$	$6.9 \times 10^{-2} \text{ s}^{-1}$
$\text{NO}_3 + \text{NO}_3 \rightarrow 2\text{NO}_2 + \text{O}_2$	$8.5 \times 10^{-13} \text{ cm}^3 \text{ molecule}^{-1} \text{ s}^{-1}$

\* From *CRC Handbook of Chemistry and Physics*, 79<sup>th</sup> Edition, David R. Lide (Ed.), CRC Press, Boca Raton, 1998, pp. 5–105.

The ratio of  $\text{O}_3/\text{NO}_3$  in our reaction conditions is expected to be  $\sim 500$  which gives the nitrate radical a more than twentyfold advantage over ozone in reaction with POPC. Although  $\text{N}_2\text{O}_5$  is present in higher concentration than is  $\text{NO}_3$ , it is of only minor importance because it reacts with water yielding  $\text{HNO}_3$  which will remain bound.<sup>25</sup>

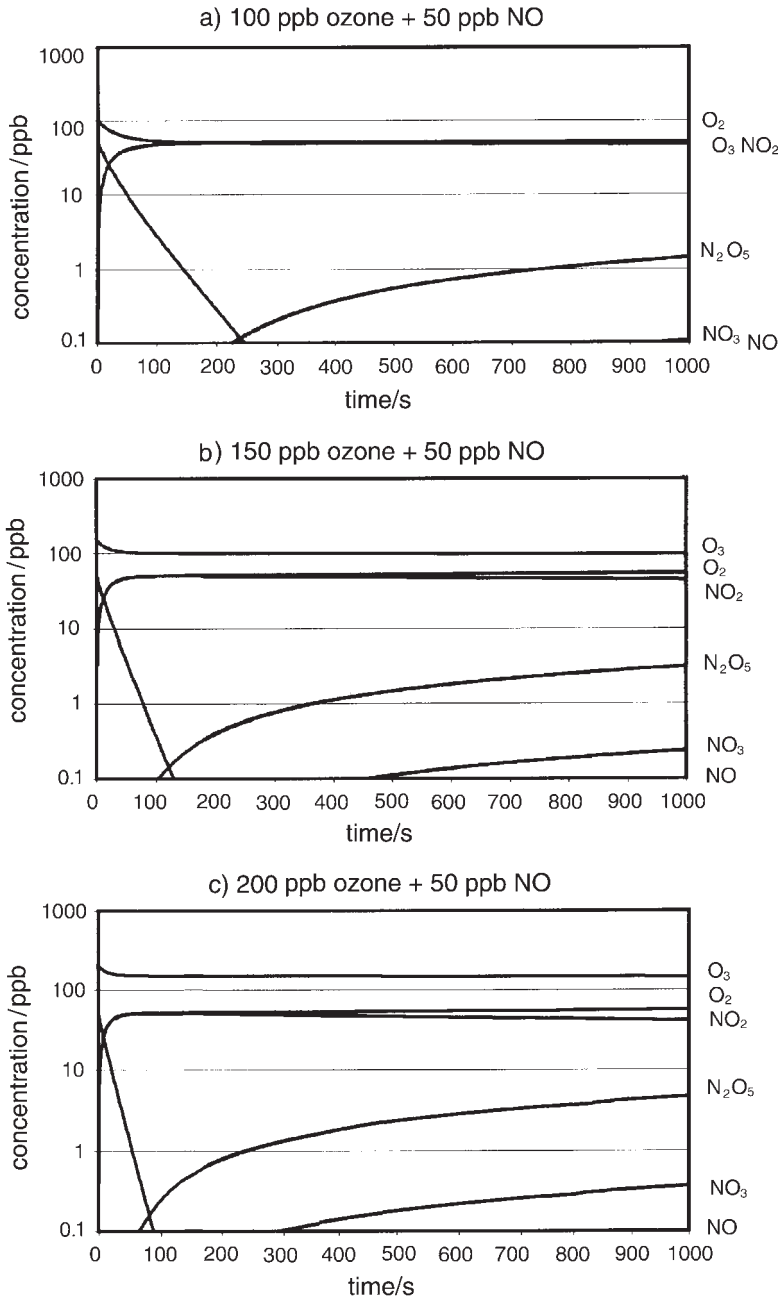
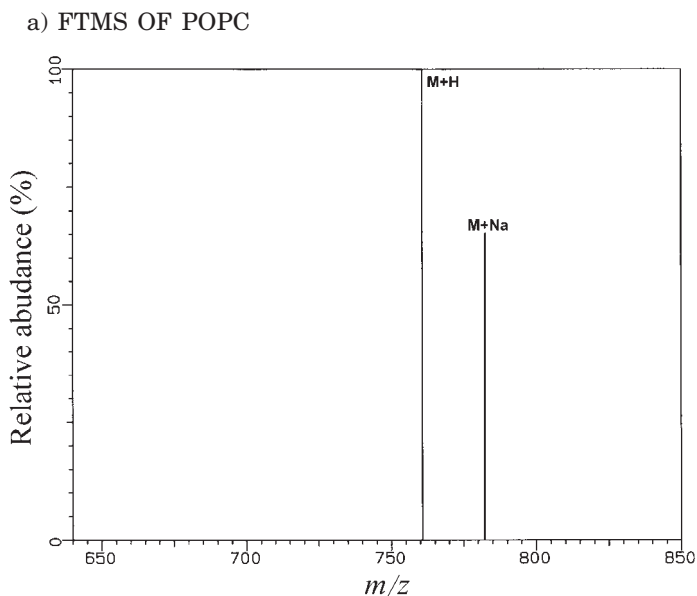

Figure 2. Simulation of first thousand second period of product development from a mixture of 50 ppb of NO with a) 100 ppb, b) 150 ppb and c) 200 ppb of ozone in air using rate constants from Table I.

## RESULTS AND DISCUSSION

Compared to prior ionization techniques, phospholipid analysis with MALDI-FTMS provides much higher mass resolving power and sensitivity.<sup>26-40</sup> The only studies of lipid ozonation products but not with  $\text{NO}_3$  present were done by Finlayson-Pitts and coworkers<sup>38,39</sup> using fast atom bombardment (FAB) and the investigation of phospholipids by Marshall and coworkers<sup>40</sup> using MALDI-FTMS. The latter study is very useful for the present investigation because it provides an experimental fragmentation scheme for POPC and introduces the use of cooled matrices which is crucial for the study of reaction products with ozone and nitrate radical.

Using a 3-nitrobenzyl alcohol matrix ( $\sim 3000:1$  matrix-to-analyte ratio) we observe negligible fragmentation of the lipid and a weaker sodiated molecular ion which sometimes is not observed. The mass spectra of POPC and its reaction products either with ozone or with ozone containing  $\text{NO}_3$  obtained using a 3-nitrobenzyl alcohol matrix are shown in Figure 3a-c. The reaction of POPC with ozone is expected to proceed *via* the unstable primary ozonide which fragments to the secondary (Criegee) ozonide *via* zwitterionic species (Scheme 1). The Criegee ozonide decomposes yielding an acid and aldehyde pair; *i.e.*, either PC/AC + ALD/C9 or PC/ALD + AC/C9, respectively (see Scheme 1 for definitions and structure). The MALDI mass spectrum of the products of incomplete ozonation reaction of POPC (Figure 3b), which is



(b) FTMS OF POPC AFTER 10 min REACTION WITH O<sub>3</sub>

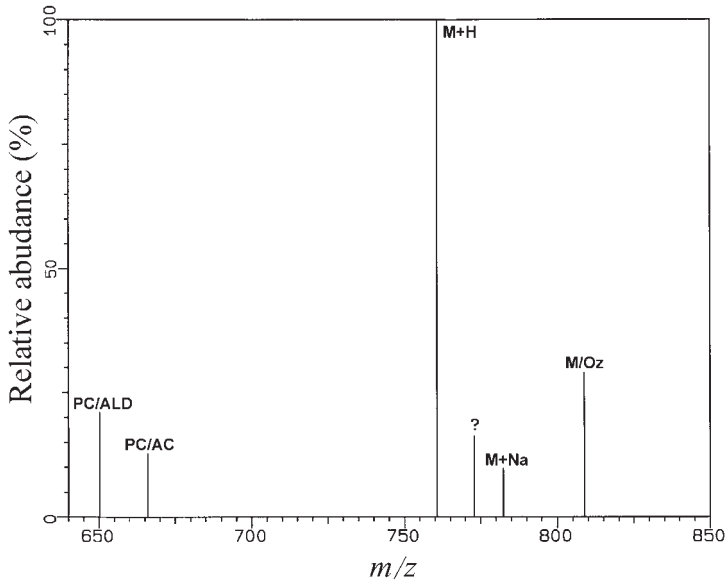

(c)

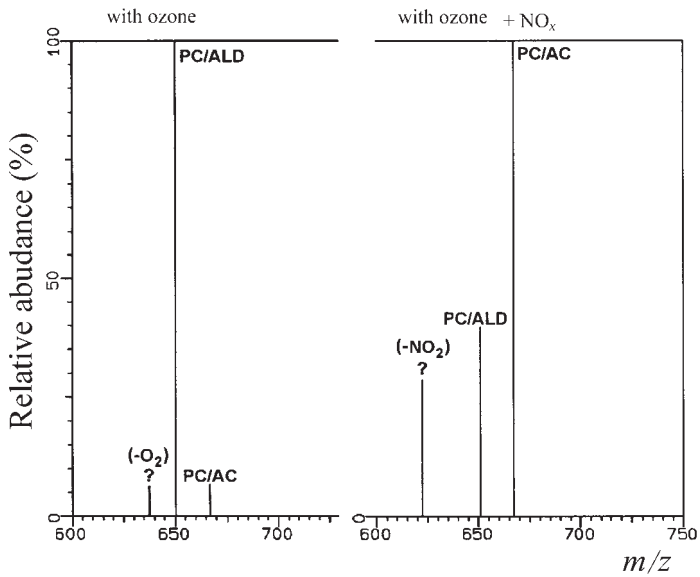
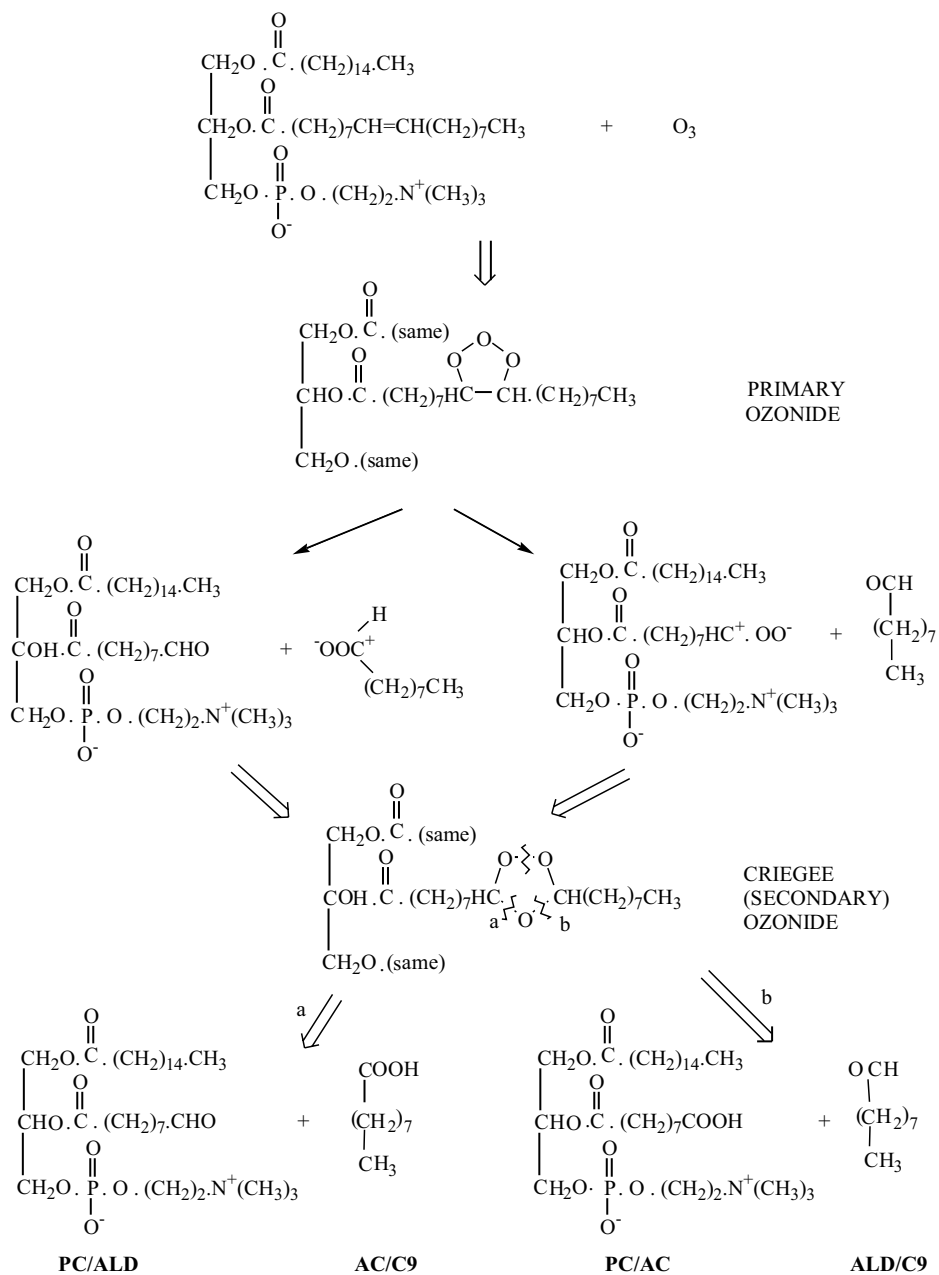

Figure 3. MALDI FTMS positive ion spectra from single nitrogen laser shots on cryogenic matrices of 3-nitrobenzyl alcohol in 3000:1 ratio with the following analytes: a) pure POPC, b) POPC after 10 min exposure to ozone and c) reaction products of POPC with ozone (LHS) and ozone/nitrogen oxides mixture (RHS).



Scheme 1

Product formation in the reaction of POPC with ozone according to the Criegee ozonation process.



similar to that obtained by using FAB,<sup>38</sup> confirms the products predicted by Scheme 1 indicating a slightly higher probability for AC/C9 than ALD/C9 formation (*i.e.* higher PC/ALD than PC/AC peak).

The comparison of the products after extensive reaction of POPC (Figure 3c) with ozone (LHS) and the ozone/nitrogen oxides mixture (RHS) shows the products are similar but with a dramatic change in their yields. In the mass spectrum of reaction products with ozone, a new ion of  $m/z = 638$  is observed which could correspond to loss of  $O_2$  from some peroxide type product structure ( $X-O_2$ ) whereas in the reaction products including nitrate radical an unknown ion of  $m/z = 623$  appears which could correspond to loss of  $NO_2$  from a similar nitrite structure ( $X-ONO$ ). The formation of new products with ( $O_3 + NO_x$ ) in dark is not surprising since  $NO_3$  exhibits much higher reactivity with unsaturated organics than ozone.<sup>24</sup>

These results indicate the importance of using realistic and more complex mixtures of oxidants in study of ambient ozone toxicity. Clearly, further study of these complex mixtures will be rewarding.

*Acknowledgements.* – This work was financed by the Ministry of Science of Croatia and submitted for support to the Fogarty International Research Collaboration Award. (Parent Grant #1R01 ES08663–01 (Friedman, Pryor) NIH/NIEHS).

## REFERENCES

1. M. Lippman, *J. Air Pollut. Contr. Assoc.* **39** (1989) 672–695.
2. W. A. Pryor, D. F. Dooley, and D. F. Church, *Mechanisms for the Reaction of Ozone with Biological Molecules: The Source of the Toxic Effects of Ozone*, in: S. D. Lee, M. G. Mustafa, and M. A. Mehlman (Eds.), *Advances in Modern Environmental Toxicology, Volume V. The Biomedical Effects of Ozone and Related Photochemical Oxidants*, Princeton Scientific Publishers, Princeton, NJ, 1982, pp. 7–19.
3. R. M. Uppu and W. A. Pryor, *Chem. Res. Toxicol.* **7** (1994) 47–55.
4. E. M. Postlethwait, R. Cueto, L. W. Velsor, and W. A. Pryor, *Am. J. Physiol.* **274** (1998) (*Lung Cell. Mol. Physiol.* **18**), L1006–L1016.
5. R. M. Kafoury, W. A. Pryor, G. L. Squadrito, M. G. Salgo, X. Zou, and M. Friedman, *Toxicol. Appl. Pharmacol.* **150** (1998) 338–349.
6. G. D. Leikauf, Q. Zhao, S. Zhou, and J. Santrock, *Am. J. Respir. Cell Mol. Biol.* **9** (1993) 594–602.
7. W. A. Pryor, G. L. Squadrito, and M. Friedman, *Free Radic. Biol. Med.* **19** (1995) 935–941.
8. W. A. Pryor and M. Wu, *Chem. Res. Toxicol.* **5** (1992) 505–511.
9. G. L. Squadrito, R. M. Uppu, R. Cueto, and W. A. Pryor, *Lipids* **27** (1992) 955–958.
10. R. Criegee, in: *Peroxide Reaction Mechanisms*, J. D. Edwards (Ed.), Wiley-Interscience, New York, 1962.
11. P. S. Bailey, *Ozonation in Organic Chemistry*, Vol 1, Academic Press, New York, 1978.
12. W. A. Pryor, B. Das, and D. F. Church, *Chem. Res. Toxicol.* **4** (1991) 341–348.

13. R. Cueto, G. L. Squadrito, and W. A. Pryor, *Methods Enzymol.* **233** (1994) 174–182.
14. W. A. Pryor and D. F. Church, *The Reaction of Ozone with Unsaturated Fatty Acids: Aldehydes and Hydrogen Peroxide as Mediators of Ozone Toxicity*, in: *Oxidative Damage & Repair: Chemical, Biological and Medical Aspects*, Pergamon Press, New York, 1991, pp. 496–504.
15. D. F. Church, M. McAdams, and W. A. Pryor, *Free Radical Production from the Ozonation of Simple Alkenes, Fatty Acid Emulsions and Phosphatidylcholine Liposomes*, in: *Oxidative Damage & Repair: Chemical, Biological and Medical Aspects*, Pergamon Press, New York, 1991, pp. 517–522.
16. W. A. Pryor, J. P. Stanley, E. Blair, and G. B. Cullen, *Arch. Environ. Health* **31** (1976) 201–210.
17. W. A. Pryor, J. P. Stanley, and E. Blair, *Lipids* **11** (1976) 370–379.
18. S. A. Penkett, N. J. Blake, P. Lightman, A. R. W. Marsh, P. Anwyl, and G. Butcher, *J. Geophys. Res.* **98** (1993) 2865–2885.
19. S. M. Aschmann and R. Atkinson, *Atmos Environ.* **29** (1995) 2311–2316.
20. T. Lindvall, *J. Work Environ. Health* **11** (Suppl. 3) (1985) 10–28.
21. W. A. Pryor, D. G. Prier, J. W. Lightsey, and D. F. Church, *Initiation of the Autoxidation of Polyunsaturated Fatty Acids (PUFA) by Ozone and Nitrogen Dioxide*, in: M. G. Simic and M. Karel (Eds.), *Autoxidation in Food and Biological Systems*, Plenum Publishing Corp., New York, 1980, pp 1–16.
22. W. A. Pryor and J. W. Lightsey, *Science* **214** (1981) 435–437.
23. A. A. Gallon and W. A. Pryor, *Lipids* **29** (1993) 171–176.
24. R. Atkinson, J. Arey, S. M. Aschmann, S. B. Corchnoy, and Y. Shu, *Int. J. Chem. Kinet.* **27** (1995) 941–955.
25. U. Schurath, *Personal communication*.
26. R. A. Klein, *J. Lipid Res.* **12** (1971) 123–131.
27. R. A. Klein, *J. Lipid Res.* **12** (1971) 628–634.
28. G. W. Wood and P. Y. Lau, *Biomed. Mass Spectrom.* **1** (1974) 154–155.
29. G. W. Wood, P. Y. Lau, and G. N. S. Rao, *Biomed. Mass Spectrom.* **3** (1976) 172–176.
30. G. W. Wood, P. Y. Lau, G. Morrow, G. N. S. Rao, and D. E. Schmidt, *J. Chem. Phys. Lipids* **18** (1977) 316–333.
31. C. G. Crawford and R. D. Plattne, *J. Lipid Res.* **24** (1983) 456–460.
32. P. Bisseret, Y. Nakatani, G. Ourisson, R. Hueber, and G. Teller, *J. Chem. Phys. Lipids* **33** (1983) 383–392.
33. P. A. Demirev, *Biomed. Mass Spectrom.* **14** (1987) 241–246.
34. J. R. Cotter and J. C. Tabet, *Int. J. Mass Spectrom. Ion Phys.* **53** (1983) 151–166.
35. G. R. Fenwick, J. Eagles, and R. Self, *Biomed. Mass Spectrom.* **10** (1983) 382–386.
36. N. J. Jensen, K. B. Tomer, and M. L. Gross, *Lipids* **21** (1986) 580–588.
37. N. J. Jensen, K. B. Tomer, and M. L. Gross, *Lipids* **22** (1987) 480–489.
38. C. C. Lai, B. J. Finlayson-Pitts, and W. A. Willis, *Chem. Res. Toxicol.* **3** (1990) 517–523.
39. B. J. Finlayson-Pitts, T. T. H. Pham, C. C. Lai, S. N. Johnson, L. L. Luciogough, J. Mestats, and D. Iwig, *Inhalation Toxicology* **10** (1998) 813–830.
40. J. A. Marto, F. M. White, S. Seldomridge, and A. G. Marshall, *Anal. Chem.* **67** (1995) 3979–3984.

**SAŽETAK****Uloga dušikovih oksida u toksičnosti ozona**

*Mitchell Friedman, Saša Kazazić, Nenad Kezele, Leo Klasinc,  
Sean P. McGlynn, Snježana Pečur i William A. Pryor*

Opisana je priprava smjesa ozona i dušikovih oksida u zraku koje sadržavaju nitratni radikal, njihova reakcija s nezasićenim lipidom 1-palmitoil-2-oleoil-*sn*- glicero-3-fosfokolinom (POPC) i određivanje reakcijskih produkata s pomoću MALDI- FTMS u usporedbi s onim koji nastaju u reakciji samo s ozonom u zraku. Rezultati pokazuju važnost nitratnog radikala za toksičnost ozona.