

# NUMERICAL ANALYSIS OF THE SKEW ROLLING PROCESS FOR MAIN SHAFTS

Received – Prispjelo: 2014-11-14

Accepted – Prihvaćeno: 2015-03-25

Original Scientific Paper – Originalni znanstveni rad

The paper discusses a new technique of skew rolling with three tapered rolls and its application to the production of long main shafts of steel that are used in light trucks. First, the design of this forming technique is described. Then the paper stresses the universality of this process, as the skew rolling technique enables forming various products using one set of rolls. The reported numerical results (workpiece shape change during rolling, maps of effective strains and temperatures as well as loads and torques) confirm that the discussed technique is suitable for producing long shafts.

*Key words:* rolling-mill, 3 roller, skew rolling, stepped shaft, finite element method (FEM)

## INTRODUCTION

Stepped axes and shafts are widely used in the machine-building, automotive and railway industries. These parts are nowadays mainly produced by metal forming methods such as die forging, rotary forging, extrusion and cross wedge rolling [1, 2].

Of the above forming methods, cross wedge rolling (CWR) deserves special attention. Owing to its numerous advantages (high output, relatively low material consumption, environmental friendliness), the process is becoming more and more popular [2, 3]. This method has, however, some shortcomings, too, e.g. it is difficult to form long parts by CWR. To do so, the length of tools (wedges) for forming parts needs to be significantly increased, which means that the rolling mill's overall dimensions are increased, too, and the duration of the production process is longer. Given the above, a method of multi-wedge rolling was developed to increase the efficiency of CWR for long parts. With this method, a workpiece is formed by several pairs of wedges at the same time [4-7]. This notwithstanding, the shortening of the tool length in CWR leads to the following consequences: one, the tools have a more complex shape (the side wedges must be designed to enable workpiece elongation by the central wedges) and, two, loads and torques are considerably higher and often exceed acceptable ranges for machinery used in industrial environments. Therefore, new effective methods for forming long axes and shafts are still being investigated.

The present paper deals with the skew rolling technique using three tapered rolls. It seems that this forming method can be used effectively for producing long axisymmetric parts.

## DESIGN OF SKEW ROLLING WITH THREE ROLLS

The design of skew rolling with three rolls is shown in Figure 1. The rolls are positioned askew at the angle  $\theta$  to the axis of the workpiece. They rotate with the same velocity and in the same direction. In addition, the rolls either converge or move apart (relative to the axis of the billet), depending on the cross sectional reduction in the shaft step being formed. Also, the distance between the rolls and the workpiece axis is synchronized with axial displacement of the workpiece-holding chuck.

The described technique for forming axes and long shafts was developed in the former Soviet Union [8]. The control of the distance between the rolls and the workpiece axis was ensured by a template. Given the developments in automatics and control processes, the motion of the rolls and chuck can now be synchronized numerically. It should also be noted that the skew rolling technique allows the use of the same set of rolls to produce various parts since their shape will only depend on the way of programming the rolls/chuck motion.

## NUMERICAL MODEL OF THE SKEW ROLLING PROCESS FOR MAIN SHAFTS

In order to investigate the technological potential of skew rolling, the process for forming main shafts was modeled numerically, as shown in Figure 2. The shaft is used in light trucks and its length is approx. 12 times higher than its maximum diameter, while one of the end stapes has a diameter that is approx. 2 times smaller than its maximum diameter.

Figure 3 shows the numerical model of the skew rolling process for producing the main shaft. The model consists of three identical rolls and a billet that has a

Z. Pater, J. Tomczak, T. Bulzak, Lublin University of Technology, Lublin, Poland

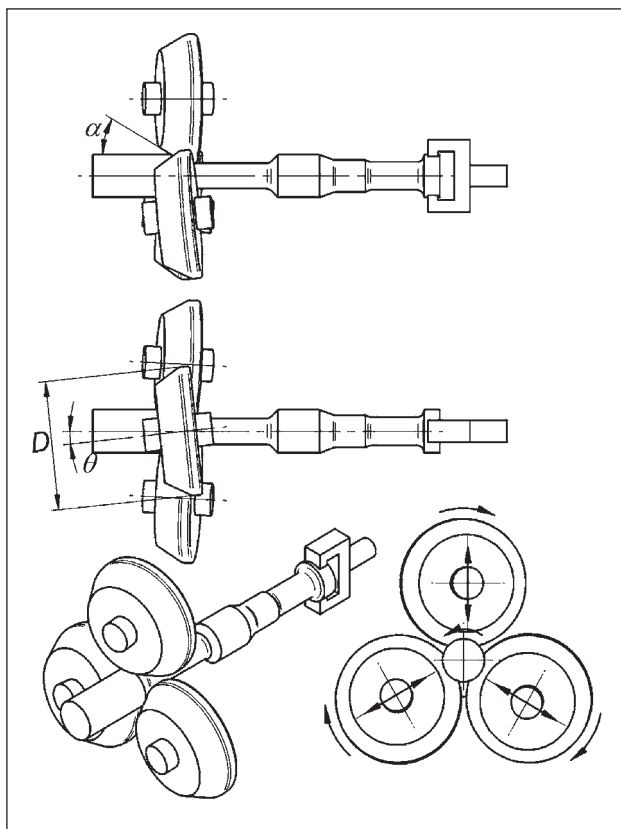

**Figure 1** Design of the skew rolling process with three tapered rolls

diameter of 56 mm and a length of 480 mm. The model does not, however, include the chuck. Instead, the flank of the billet is fixed and the axial motion of the chuck is replaced with the axial motion of the rolls (this operation did not alter the process kinematics, but rather helped facilitate the numerical simulation). During the forming process, the rolls rotate in the same direction at 60 revolutions per minute, linear to both their own axis (velocity  $v_x$ ) and to the axis of the billet (velocity  $v_r$ ). The variations in the velocities  $v_x$  and  $v_r$  are shown in Figure 4.

The shaft was assigned the properties of C45 steel, the material model of which is defined by the following equation:

$$\sigma_p = 4105^{(-0,003557)} \varphi^{(-0,000137-0,00507)} \cdot e^{(\frac{-0,000027-0,0281}{\varphi})} \dot{\varphi}^{(0,000187-0,02416)} \quad (1)$$

where:  $\sigma_p$  is the yield stress,  $\varphi$  is the effective strain,  $\dot{\varphi}$  is the strain rate,  $T$  is the temperature.

As for other parameters, the friction factor on the material-tool surface was set to 0,95, the temperature of the rolls was 50 °C, the billet temperature was 1 150 °C, while the material-roll heat transfer coefficient was set to 20 000 W/m<sup>2</sup>K.

The described numerical model was designed using the commercial FEM simulation software suite Simufact.Forming v. 12. This software has been long employed to investigate skew and cross rolling processes

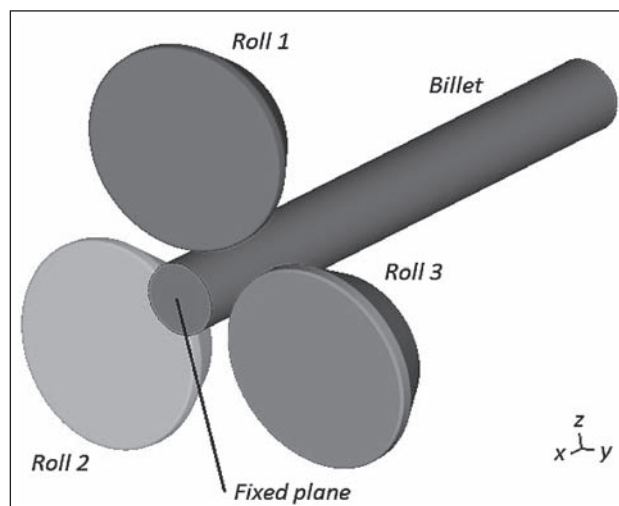

**Figure 2** Numerical model of skew rolling for main shafts

[9, 10], and the numerical results show good agreement with the verifying experimental results.

## NUMERICAL RESULTS

The numerical results demonstrate that the method of skew rolling with three rolls can be used to produce main shafts of the desired shape. Figure 5 illustrates the changes in the shaft's shape in the consecutive stages of the rolling process. The shaft steps are formed gradually one after another. On its ends, the shaft has allowance be removed (e.g. by machining). It is worth noting that the shaft is not curved despite its high slenderness, which can undoubtedly be attributed to the action of axial tensile stresses that occur in the workpiece region between the rolls and chuck (fixing).

Figure 6 shows the effective strains on the shaft's surface and in its axial section. Analyzing their distribution pattern, it can be observed that the strains are arranged in layers and have the highest magnitude at the surface. In contrast, the lowest strains can be observed in the axial zone, which results from friction on the material-tool contact surface. Moreover, it was found that the strain magnitude clearly depends on the reduction in step diameter (an increase in the diameter reduction leads to even higher strains). The observed distribution pattern of strains is typical of skew and cross rolling processes [3].

The duration of the forming of the main shaft was set to 27,5 s, which is quite long. During the process, however, the tools are in local contact with the material, so the temperature of the material does not drop significantly. The temperature in the entire volume of the shaft remains in the range that is suitable for hot metal forming, as is proved by the temperature distribution pattern given in Figure 7. It should be noted that the losses of heat that is transferred to the tools and environment are compensated for by the heat generated by friction.

The loads and torques shown in Figure 8 provide interesting insight into the process. It can be observed

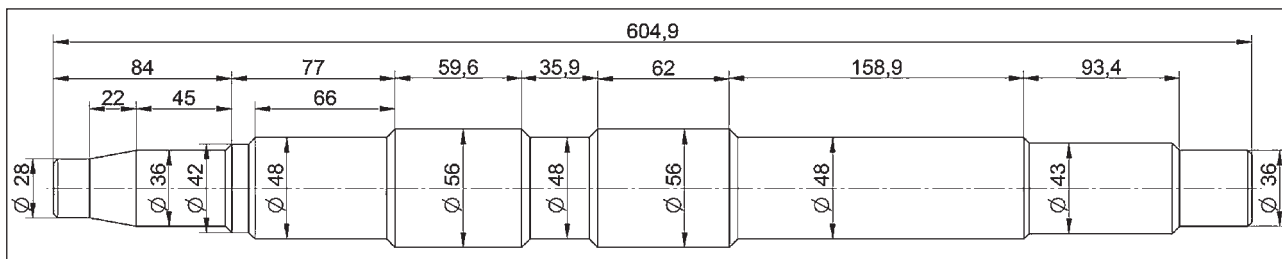

Figure 3 Main shaft for light trucks and its major dimensions

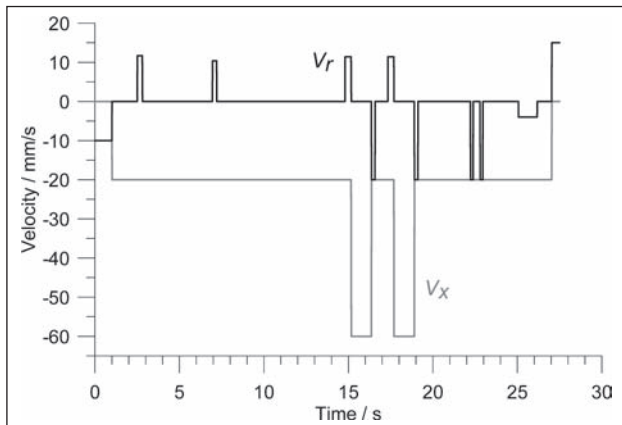

Figure 4 Linear velocities of the rolls: axial velocity  $v_x$ , radial velocity  $v_r$

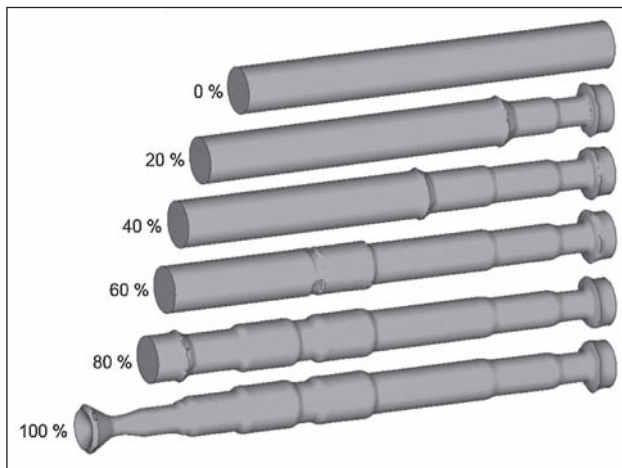

Figure 5 Shape changes in the main shaft in consecutive stages of the skew rolling process

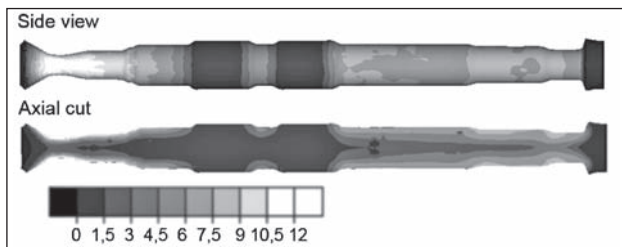

Figure 6 Effective strains in the main shaft produced by skew rolling with three rolls

that both the torque and the loads on the chuck (axial load) and on the roll (radial load) strongly depend on cross sectional reduction. The higher the reduction, the higher the above parameters are. It is worth emphasiz-

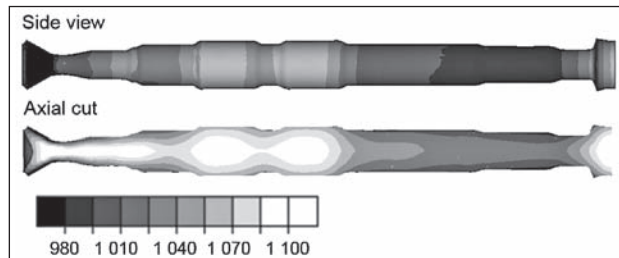

Figure 7 Temperature (in °C) in the main shaft produced by skew rolling with three rolls

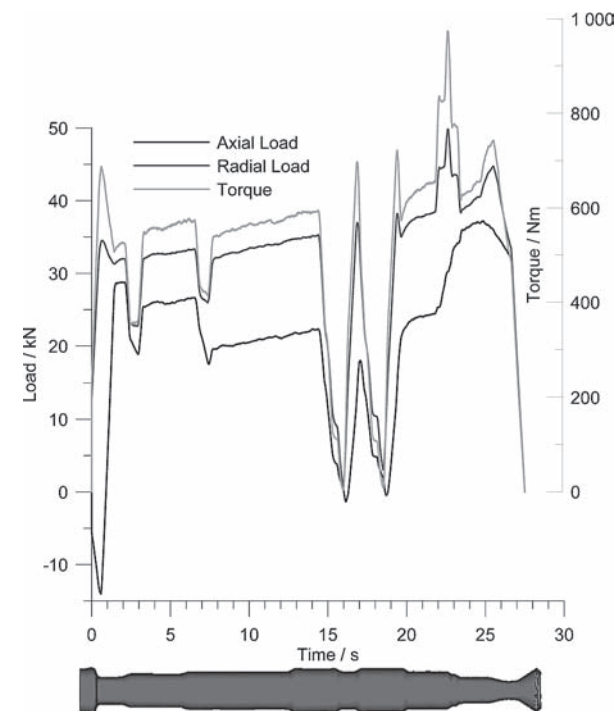

Figure 8 Loads acting on the roll (radial load) and chuck (axial load) as well as the torque on the roll in skew rolling for main shafts

ing that both the maximum loads (below 50 kN) and maximum torque (below 1 000 Nm) are low when compared to the overall dimensions of the workpiece. This means that the rolling mill used for skew rolling can be made lightweight and its power supply will be lower than that to standard machines used for CWR processes.

## CONCLUSIONS

The conclusions to be drawn from the numerical results are as follows:

- the skew rolling method can be used to form long parts such as stepped axes and shafts;
- the skew rolling method is highly universal (one set of rolls can be used to form products of various shapes);
- the strains a part produced by skew rolling are arranged in layers (they have a ring-shaped pattern), which is characteristic of cross rolling processes;
- although the production process is relatively long, the material is not excessively cooled, a phenomenon which would hinder the forming process;
- the loads and torque in skew rolling are low when compared to the overall dimensions of the formed parts;
- the research on skew rolling for long axisymmetric parts should be continued and extended to cover the problem of forming hollow parts.

## REFERENCES

- [1] K. Lange, Handbook of Metal Forming. Ed. McGraw-Hill Book Company 1985.
- [2] Z. Pater, Development of Cross Wedge Rolling Theory and Technology Steel Research International. "Special edition: Metal Forming 2010" (2010), 25-32.
- [3] Z. Pater, Cross-Wedge Rolling, Comprehensive Materials Processing; Button, S. T., Ed.; Elsevier Ltd. 3 (2014), 211-279.
- [4] J. Zhao, L. Lu, The application of multi-wedge cross wedge rolling forming long shaft technology, Applied Mechanics and Materials 101-102 (2012), 1002-1005.
- [5] J. Zhou, J. Yu, Q. Zeng, Analysis and experimental studies of internal voids in multi-wedge cross wedge rolling stepped shaft, The International Journal of Advanced Manufacturing Technology 72 (2014), 1559-1566.
- [6] B. Sun, et al., Feasibility Study on Forming Hollow Axle with Multi-wedge Synchrostep by Cross Wedge Rolling, Applied Mechanics and Materials 201-202 (2012), 673-677.
- [7] X. Shu, Z. Li, W. Zu, Bending Analysis and Measures of the Forming of Automobile Semi-axle on Cross-Wedge Rolling with Multi-wedge, Applied Mechanics and Materials 184-185 (2012), 75-79.
- [8] E. R Sor: New rolling processes. Ed. Metalurgizdat, Moscow 1960 (in Russian).
- [9] A. Tofil, Research of New Splitting Process of Pipe Billets, Archives of Metallurgy and Materials 58 (2013) 3, 725-729.
- [10] J. Bartnicki, FEM analysis of hollow hub forming in rolling extrusion process, Metalurgija 53 (2014) 4, 637-640.
- Note:** The professional translator for English language is M. Jung, Lublin, Poland