

## USE OF X-RAY RADIOGRAPHY IN FINDING DEFECTS IN METAL-MATRIX COMPOSITE CASTS

Received – Prispjelo: 2007-04-12  
Accepted – Prihvaćeno: 2008-02-29  
Preliminary Note – Prethodno priopćenje

The aim of the carried out studies was to establish in what degree X-ray radiography is useful for finding defects in metal-matrix composite materials. These materials have various defects due to their specific composition. Especially when we take composites produced with casting methods into consideration. An effort to establish a degree of the influence of the phenomenon of electromagnetic diffusion on the boundary of matrix/reinforcement phases was made in the results analysis of the studies.

*Key words:* metal-matrix composite, X-ray radiography, defects, cast

**Rabjenje radiografije x-zrakama u pronalaženju grešaka lijevanih kompozita metalne matrice.** Cilj članka je utvrđivanje u kojoj razini primjenjiva je radiografija x-zrakama u pronalaženju grešaka lijevanih kompozita metalne matrice. Ovi materijali imaju različite greške glede njihovog specifičnog sastava. Posebice kada se motre kompoziti dobiveni ljevanjem.

Skrb utvrdit stupanj utjecaja fenomena elektromagnetne difuzije na granice matrica-ojačane faze, daje se kao rezultat ove analize u članku.

*Gljučne riječi:* kompoziti metalne matrice, radiografija x-zracima, greške, odljevak

### INTRODUCTION

Penetrating radiation originating in the disintegration of radioactive preparations and the emission from the anode of an X-ray tube is used in examining the quality of metal products such as casts. The phenomenon of diversification of this radiation absorption in an examined material is used here.

The weakening of radiation depends on the thickness of an X-rayed object. The degree of X-ray radiation weakening is also connected with the density of examined materials. The participation of so-called microporosity in a cast can be established this way.

Standard examinations allow to detect fractures of casts and macrodiscontinuities like gas cavities, as well as discontinuities connected with contraction phenomena occurring during metal solidification [1-2].

Progress in machine structure is connected, among others, with the introduction of cast metal-ceramic composite materials. They are more and more widely used in combustion engines (pistons, heads, blocks), various casings and frames (elements for automotive industry), sports equipment, etc. Therefore, it is necessary to examine composite materials quality [2-4, 5]. The follow-

ing methods are used: ultrasonic, of rotary currents, acoustic, thermic and also of penetrating radiation.

In some cases, very expensive studies are carried out using penetrating radiation in tomographs [3, 5, 7]. Classical examination with X-ray radiation is a cheap and reliable method of composite materials examination. The method of recording results in a form of a document is also important.

A composite material is characterized by a complex structure. There are at least two different materials functioning as matrix and reinforcement. For cast composites, a matrix materials are most often Al alloys, and also Mg and titanium alloys. Copper alloys and steel can also be found. The reinforcement material, occurring as fibres or particles, is usually ceramic, (carbides, oxides, borides) and also carbon.

X-ray radiation may help in establishing irregularities of the arrangement of reinforcing structure (preform) in casts reinforced locally (Figure 1), and also in finding macrofractures (Figure 2).

From the point of view of the phenomenon of penetration of an electromagnetic wave (which X-ray is) through a material with a complex structure (which a composite is), we should take into consideration varied weakening of radiation in various materials, and also the occurrence of the phenomenon of diffraction and reflection on numerous phase boundaries (matrix-reinforce-

K. Gawdzińska, J. Grabian, W. Przetakiewicz, Department of Naval Materials Engineering, Maritime University of Szczecin, Szczecin, Poland

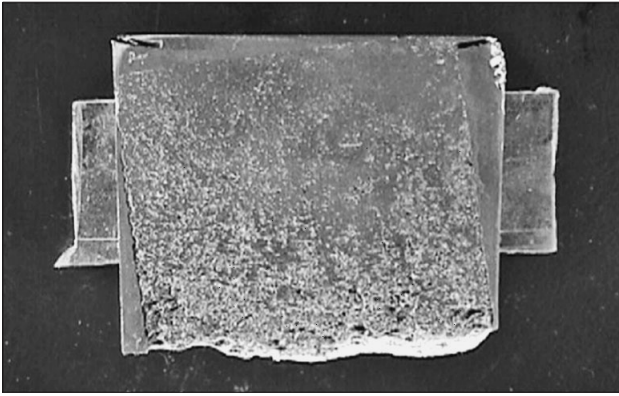

Figure 1. Irregular arrangement of reinforcing structure found using X-ray radiation

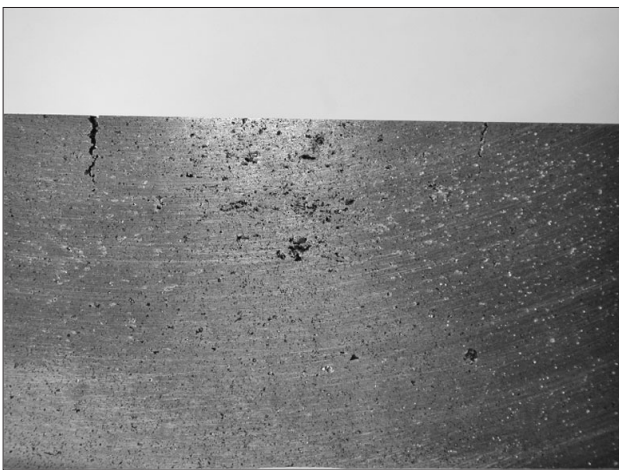

Figure 2. Macrofracture of composite cast

ment). The use of reinforcement in the form of particles, fibres (ceramic or carbon) in metal-matrix composites gives a complex effect of weakening of radiation permeating through this material [3, 7].

Therefore, it is advisable to conduct a study in order to show if X-ray radiation diffusion on reinforcement elements significantly limits the ability to record a composite discontinuities like fractures or macroporosity.

## METHODS OF STUDIES

Composite casts made with so-called squeeze casting method were used in the studies. Reinforcement, in the form of disordered fibres, was formed as cylinder-shaped profiles (preforms). It was placed (in some cases it was heated to temp. 500°C) in a metal mould (Figure 3) with temperature 350°C, which was filled with matrix metal (AlSi11) with temperature 750°C, and then, using a punch, the perform was saturated. The pressure of liquid metal was 10 MPa.

Samples with diameter of 60mm were cut out of the casts as shown on the diagram in Figure 4. The thickness of samples was 10 mm.

Two composite samples with disordered aluminosilica fibres and carbon reinforcements were made.

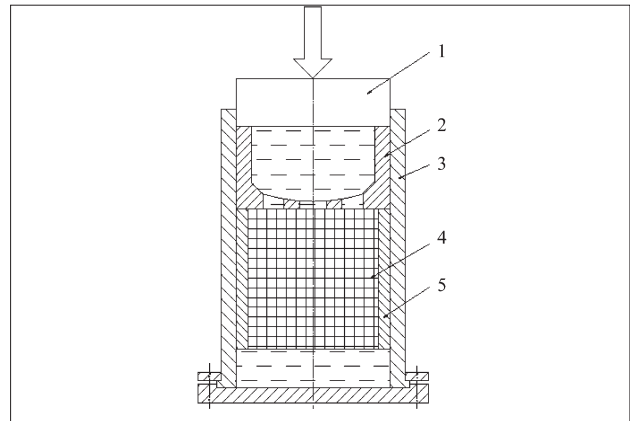

Figure 3. Mould for making casts: 1 – punch, 2 – piston, 3 – hollow, 4 – ceramic profile, 5 – reinforcement seat

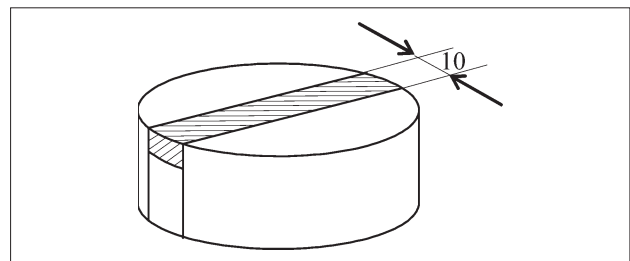

Figure 4. Place of cutting out sample

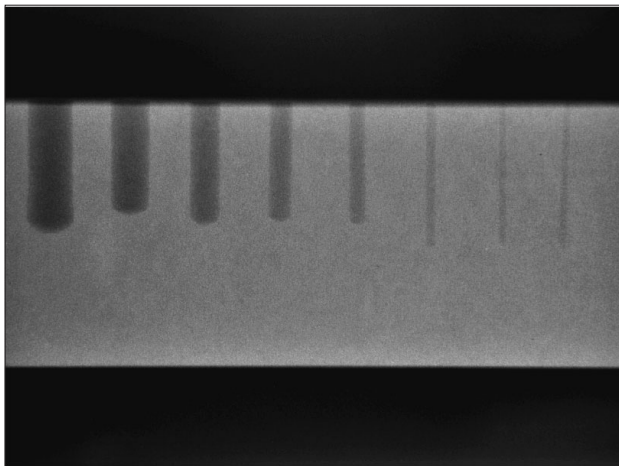

Figure 5. Samples used in the study

A sample without reinforcement in the same conditions for comparison purposes was made. The samples were presented in Figure 5.

Blind holes with diameters of 3; 2,5; 2; 1,5; 1; 0,7; 0,5; 0,3 mm were made in the samples. The holes with three smallest diameters were made with an electroerosion method.

The samples were exposed to X-rays. Super Liliput 200 apparatus was used with the following settings: plate current 5 mA, voltage 150 kV, distance of radiation source from an examined object 400 mm. Radiation going through the examined samples was recorded on standard X-ray film.



1)

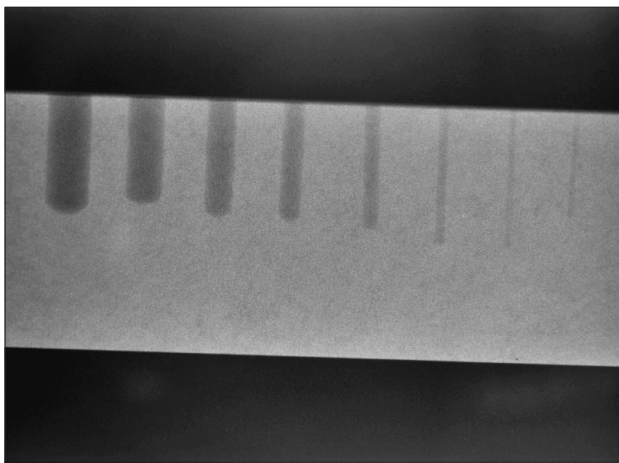

2)

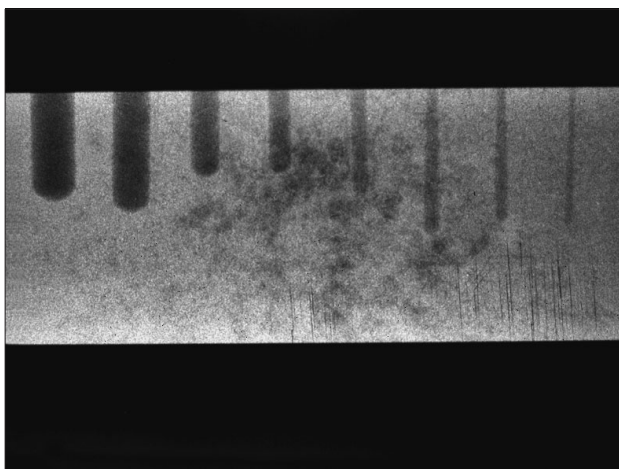

3)

**Figure 6.** Effect of X-ray examination of samples: no. 1 – matrix AlSi11; no. 2 – matrix AlSi11/carbon fibre; no. 3 – matrix AlSi11/aluminosilica fibre

## RESULTS OF STUDIES

The effect of the samples' examination in the form of appropriate blackening of X-ray film was presented in Figure 6.

**Table 1. The results of optical density studies**

Sample no.	Material	Optical density beyond discontinuities	Optical density within discontinuities		
1	AlSi11	1,8; 1,8; 1,9	1,83	1,9; 2,0; 2,1	2,00
2	AlSi11/Al <sub>2</sub> O <sub>3</sub> -SiO	1,8; 1,8; 1,8	1,80	1,8; 1,9; 1,8	1,83
3	AlSi11/C	1,8; 1,7; 1,7	1,73	1,9; 2,0; 2,0	1,96

Obtained radiograms were analysed for optical density. The results of optical density studies were presented in Table 1. The optical density was examined beyond the area of discontinuity (holes) and within the area of discontinuity.

It was noticed at the same time that in all cases, discontinuities (holes) of 0.3 mm were visible.

## CONCLUSIONS

1. Comparative studies concerning the weakening of X-ray radiation going through the studies samples showed slight differences in optical density of the radiogram.

2. In all cases, for a cast thickness 10 mm, discontinuity of 0,3 mm is recorded.

3. The examination may be used in diagnostics of composite casts, and may be especially useful in detecting and establishing the size of a defect like porosity.

## REFERENCES

1. K. Gawdzińska: Analysis and classification of defects in the structure of metal-matrix saturated composite casts, doctor's dissertation, Szczecin University of Technology, 2002.
2. J. Obraz: Zkoušení materialu ultrazvukem, SNTL Nakladatelství Technické Literatury, Praha 1989.
3. W. Orłowicz, Z. Opiekun, Non-destructive quality control of thermally processed casts, materials from Scientific Research Committee, 1993.
4. W. Orłowicz, Use of ultrasounds in foundry, Solidification of Metals and Alloys, year 2, no. 45, PAN, Katowice 2000.
5. PN-76/M-70008 Non-destructive Examinations. General Terms and Names.
6. PN-77/M-70001 Industrial Radiographic Examinations. Indicator of Image Quality. Requirements.
7. J. Sobczak, Metal-matrix Composites, Institute of Foundry and Institute of Road Transport, Cracow – Warsaw 2001.

**Note:** The responsible for English language is Author K. Gawdzińska.