

SELECTED NEW TECHNOLOGIES AND RESEARCH THEMES IN MATERIALS FORMING

Received – Prispjelo: 2008-10-24
Accepted – Prihvaćeno: 2009-07-10
Review Paper – Pregledni rad

The article gives a review of selected new technologies of materials forming. That is selected 10 procedures, first, high pressure torsion processing, at the end, metal injection molding. All the new procedures have good performance and in the future for expect more the application in industry.

Key words: new forming technologies, research, the performance, the application

Odabrane nove tehnologije i zadaci istraživanja u oblikovanju deformiranjem materijala. Članak daje osvrt odabranih novih tehnologija u oblikovanju deformiranjem materijala. To je odabranih 10 postupaka, prvi, visokotlačna torziona obradba i na kraju, lijevačko injektiranje metala. Svi novi postupci imaju dobre karakteristike i u budućnosti za očekivati veću primjenu u undustriji.

Ključne riječi: nove tehnologije oblikovanja deformiranjem, istraživanje, karakteristike, primjena

HIGH PRESSURE TORSION PROCESSING

Cyclic plastic deformation introduced by forging with a rotating lower anvil leads to materials with grain size between 20 and 200 nm, depending on various factors. This severe plastic deformation process known as High Pressure Torsion (HPT) can be used for forming nanopowders in order to refine their microstructure. Mechanical properties of such products are given by the amount of plastic deformation, i.e. by the total amount of strain [1]. Understanding this relationship and the impact of repetitive deformation is crucial. It is not only the individual deformation cycles but the plasticity limit as well that play a role in this process. Software simulation is used for modelling laboratory or plant processing prior to its actual application. Figure 1 outlines the principles of the HTP process. The workpiece is held and compressed between the upper and lower anvils. The lower anvil rotates, thereby exerting shear forces through friction between its surface and the material. Development of the software model was based on dislocation structures.

$$\tau_c^r = \alpha G b \sqrt{\rho_c} \left(\frac{\dot{\gamma}_c^r}{\dot{\gamma}_0} \right) \quad (1)$$

$$\tau_w^r = \alpha G b \sqrt{\rho_w} \left(\frac{\dot{\gamma}_w^r}{\dot{\gamma}_0} \right) \quad (2)$$

It comprised the classical equation (1) and the equation (2), where $\dot{\gamma}_c^r$ and $\dot{\gamma}_w^r$ denote the shear strain rate in

J. Klíber, Faculty of Metallurgy and Materials Engineering, VŠB-TU, Czech Republic

I. Mamuzić, Faculty of Metallurgy University of Zagreb, Sisak, Croatia.

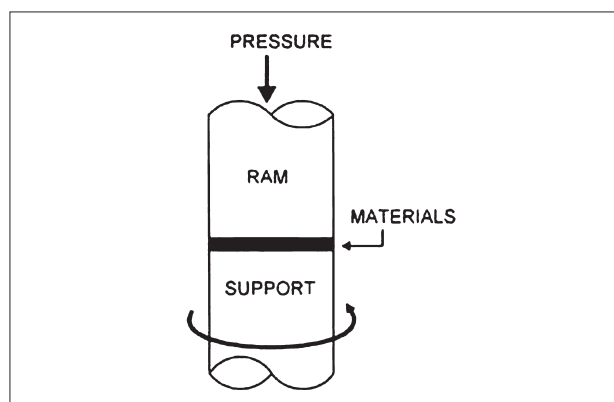

Figure 1 Schematic diagram of high pressure torsion processing [1]

the centre of the cell and near its boundary, respectively, G is the shear modulus of elasticity, b denotes the Burgers vector, $\dot{\gamma}_0$ is the initial reference shear strain rate, $1/m$ denotes the strain rate coefficient and α is normally 0,25. The above equations are useful for determining the dislocation density and understanding how the hardening of material depends on the imparted strain.

The actual simulations were carried out using the DEFORM software. The experimental material was polycrystalline copper. Its hardening equation had the form of a power function up to about 450 MPa (peak strain) at true strain of about 5. Computer simulation was also used to determine the diameter and height of the workpiece, which were 20 and 10 millimetres, respectively. Figure 2 shows its results: section a) is a classical upsetting process, section b) refers to upsetting with a single revolution and section c) displays results of upsetting with two revolutions. Upon simple upsetting

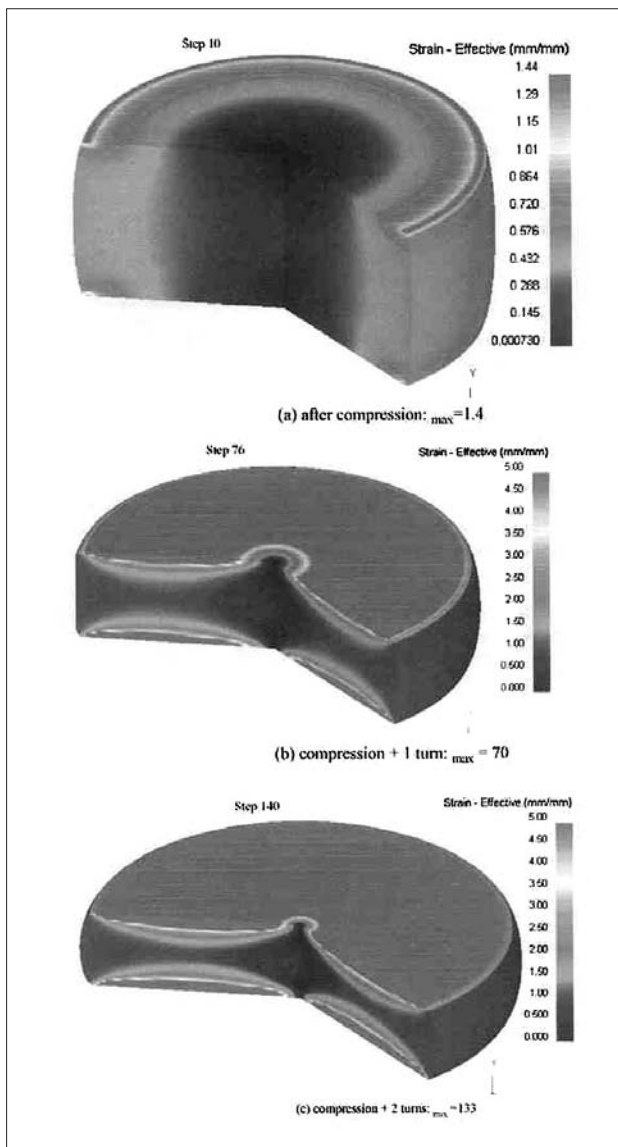

Figure 2 Deformed geometries with effective strain contour after compression a) $\epsilon_{\max}=1,4$, b) $\epsilon_{\max}=170$, c) $\epsilon_{\max}=133$, [1]

without torsion, the microstructure in the centre of specimen was less distorted than subsurface layers. With increasing number of revolutions, the amount of strain introduced into subsurface layers under the anvil increased. The main finding of this study is that the strain variance in the axial direction is much more pronounced than the strain variance in the radial direction.

FORGING A STEEL GEAR WHEEL

This is the KOBO method using a rotating and tilting upper anvil [2]. Conventional forming typically requires heating of the workpiece to about 1100 °C, which is accompanied by grain growth and surface oxidation. This applies to processes with lower forming temperatures as well. (In such case, stresses and forces required for forming are higher.) The KOBO technique was tested at temperatures between 600 and 950 °C with an actual forged piece of medium-carbon steel (0,45 % C). Experimental conditions in-

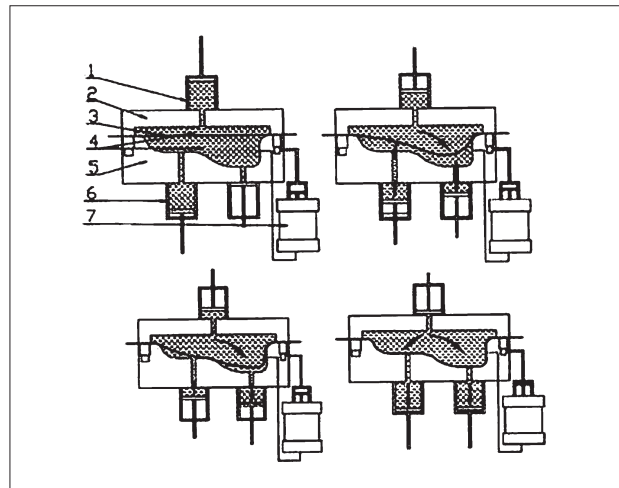

Figure 3 Schematic diagram of VPF: (1) medium injection cylinder; (2) upper die; (3) blank sheet; (4) viscous medium; (5) die; (6) medium outlet cylinder; (7) blank holder cylinder [4]

cluded a vertical velocity of the anvil of 5 mm/s, the anvil tilt angle of $\pm 4^\circ$ and a frequency of 3 Hz. The total forging time was no more than 15 seconds.

The results suggest that

- comparable values of stress and applied forces can be achieved by the KOBO technique at lower temperatures,
- the technique improves the filling of the die cavity,
- the resulting microstructure and mechanical properties are comparable to those of forgings produced by conventional forging.

VISCOUS PRESSURE FORMING

This technique begins to be used mainly in pressing. Viscous Pressure Forming (VPF) differs from classical pressing in that it uses a semi-solid viscous material as a pressure medium. The viscous medium can be applied on one or both sides of the sheet in order to improve its formability. The method is intended for processing of high-strength, difficult-to-form materials and for producing 3D features. It was first used in 1992 and developed and improved subsequently. In the process, the viscous medium forces the material to fill the die cavity. A schematic drawing is shown in Figure 3. The technique is typical with very low strain rates of about 10^{-1} to 10^{-4} s^{-1} . The viscous medium exerts both normal pressure and shear stress, which makes the VPF different from conventional pressing, see Figure 4, as shown by a different stress-strain curve.

HYBRID NEURAL-GA MODEL TO PREDICT AND MINIMISE FLATNESS VALUE OF HOT ROLLED STRIPS

Solving this problem is extremely difficult, as the resulting flatness of hot-rolled strip depends on a number

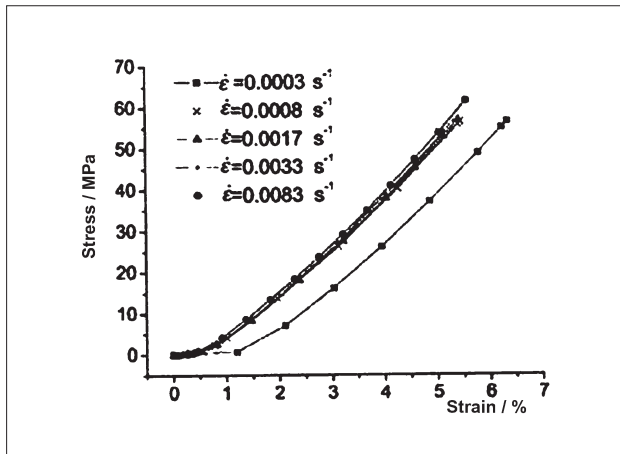

Figure 4 Relationship curves between the stress and strain of the viscous medium

of both deterministic and random variables [5]. The flatness of the strip is given by changes in its thickness in longitudinal and transverse directions, as expressed by equations (3) and (4) [6].

$$\text{Stepness} = (H/L) \times 100\% \quad (3)$$

$$\text{Flatness index} = (\Delta L/L) \times 10^5 = (\pi H/2L) \times 10^5 \quad (4)$$

The rolling process is rather non-uniform. One could even say that the resulting strip flatness is independent from certain input parameters. Conventional control methods for rolling mills require complex mathematical patterns, which are often difficult to apply on-line. A neural network combined with a genetic algorithm is therefore a novel approach aimed at minimization of flatness indices. The experiment was carried out in the second rolling line of a continuous mill with 6 four-high stands and at the forming temperature between 870 and 900 °C. These stands were equipped with the CVC technology with an axial movement of working rolls of ± 150 mm. The total of 18 variable parameters were used for controlling the process, such as: average flatness, entry thickness at individual stands 1..n, entry and exit temperatures, exit speed, strip width and others.

Neural analysis is rather well known, and therefore only the principles of the genetic algorithm will be explained here. Genetic optimisation analysis is based on

the natural selection process. The algorithm is applied to a data set termed population. While the experiment gradually produces a new population, genetic criteria are applied until the optimum result is reached.

The practical effects were tested in a process with the final thickness of 1,82 to 2,22 mm. The hybrid model showed marked improvement in flatness parameters, see equations (1) and (2).

SUPERPLASTIC PROPERTIES OF PB-62%SN EUTECTIC ALLOY UPON EQUAL CHANNEL ANGULAR PRESSING

The group of materials processed by the ECAP techniques is expanding gradually. They range from simple copper alloys to difficult-to-form magnesium alloys [7]. This process takes place at rates of about 10^{-3} s^{-1} . If the input material grain size is about $14 \mu\text{m}$, the process involves superplastic deformation. In this experiment, 1, 4, 8 and 16 passes through the angular channel were used at the room temperature. The resulting grain size decreased to $8 \mu\text{m}$ and the elongation was between 2 000 and 3 000 %. This alloy possesses rather low strength of $5 \div 20 \text{ MPa}$. In accordance with the theory, the strain rate has significant impact on its behaviour, see Figure 5a. Additional tests have shown that with the strain rate of 10^{-4} s^{-1} , even higher elongation values can be achieved. Peak stress values have not been changing significantly with increasing number of passes, unlike the strain values, at which peak stress occurs, Figure 5b.

THREE DIMENSIONAL THERMO-MECHANICAL SIMULATION OF TUBE FORMING PROCESS IN DIESCHER'S MILL

Production of thick-walled seamless tubes is normally based on either of the Mannesmann or Stiefel processes. Diescher process uses additional support rolls in cross piercing. Its simulation was performed in the software MSC. SuperForm 2005 [8]. The study was based on a real-world process (100Cr6 steel, specific thermal

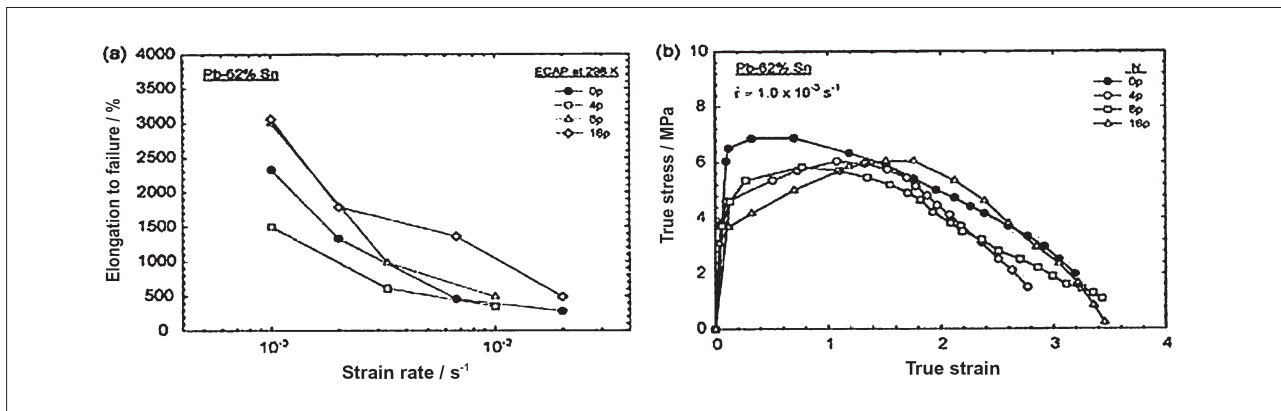

Figure 5 (a) Elongation to failure as a function of a strain rate; (b) stress as a function of strain in an unpressed and pressed PB-62 %Sn eutectic alloy [7]

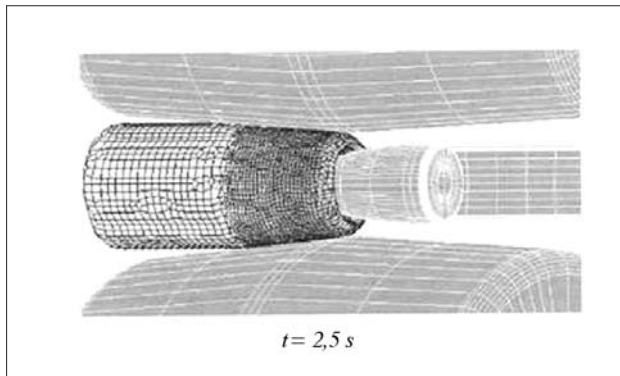

Figure 6 Calculated by FEM progression of shape (together with the strain distribution) of the workpiece during piercing at the time $t=2,5$ s [8]

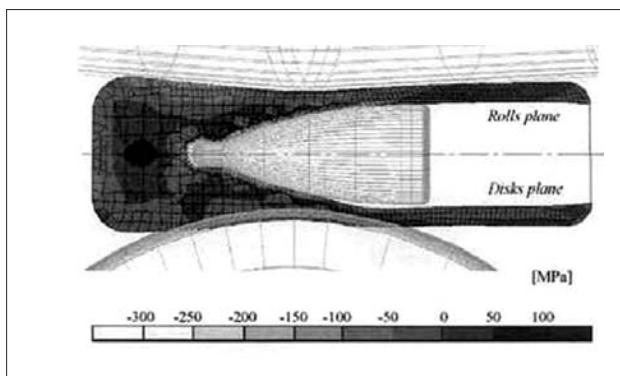

Figure 7 Mean stress σ_m distribution, calculated for $t=5$ s [8]

dilation values and other technological parameters). Results of the piercing process are presented in dependence on the time elapsed: an example is the simulation at 2,5 seconds into the process when the mandrel entered the round billet (Figure 6). Very interesting distribution of strain rate was found near the points of contact between the billet being pierced and the rolls and support Diescher discs. The strain rate indicated by the computer simulation was 40 s^{-1} . Similar results were obtained with the stress distribution see Figure 7. This figure shows high tensile stresses indicated by dark areas along the axis of the billet. These are the locations where the material loses its cohesive strength and may develop cracks. Considerable compression stresses introduced by the mandrel lead to smoothing down the inner surface of the billet being pierced.

CROSS WEDGE ROLLING

This new wedge rolling method uses one wedge plate and two shaped rolls. It is termed Wedge-Rolls Rolling (WRR) [9]. As a modern forming method it is used for making stepped shafts, connecting rods and shanks. However, it can be used for shaping billets into non-symmetric formed products as well. Its benefits include high productivity, material utilization good to excellent mechanical properties of products, simple auto-

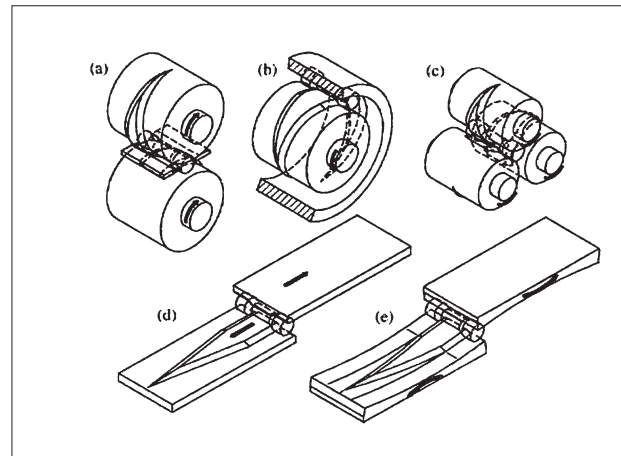

Figure 8 Methods of cross-wedge rolling in configurations: (a) two wedges, (b) wedge concave segment, (c) two flat wedges. (d) two concave wedges [9]

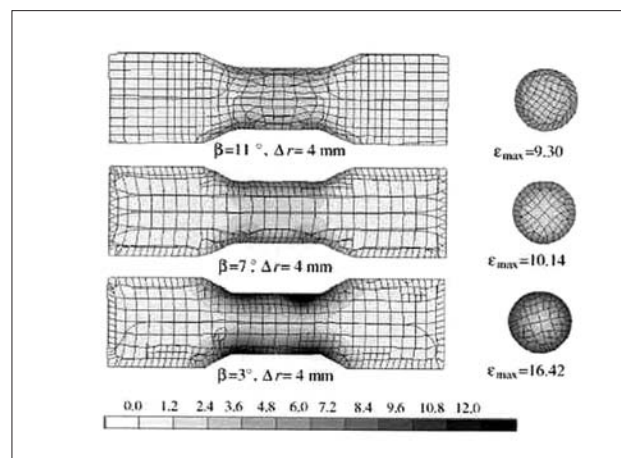

Figure 9 Calculated strains distribution in parts by means of WRR at: $d_0 = 25$ mm. [9]

mation and environmentally favourable low energy consumption. There are a number of alternatives of the Cross-Wedge Rolling (CWR) method, shown in Figure 8. The effects of deformation steps within the material were explored in greater detail with the aid of the MCS. Superform 2004 software. One of the results is shown in Figure 9. With increasing angle β , which is the angle of the apex of the wedge, the maximum strain value decreases. Computer simulation allows to optimise the remaining geometric parameters of the wedge as well. This leads to optimisation of the strain introduced and of the final dimensions of the formed piece.

PROGRESS IN SHELL HYDROFORMING

This method has been known for about 20 years but was mostly presented to the public through works of art such as the one in Figure 10 which is a steel football produced by this method [10]. The method is also known as Integral Hydro-Bulge Forming (IHBF). The complexity of its products has been developing: from single-layer to double-layer parts, from conventional pressure levels to



Figure 10 Hydrobulged steel football of 4000 mm diameter [10]

high-pressure applications, from spherical to ellipsoid and cylindrical structures and from single-thickness walls to products with variable wall thickness. At present, one of the largest products made by this process is a spherical tank with the radius of 9 400 mm and a thickness of 24 mm.

This technique does not require the use of dies. The process is based on forcing a liquid into a product with a predefined shape. The volume of the liquid increases with continuing deformation. Compared to traditional manufacturing of similar products, the hydrobulging method brings advantages in flexibility of production, being suitable for single pieces or large series, in markedly shorter lead-time, and lower equipment cost. Large plastic deformation reduces residual stresses in the vicinity of welded joints.

RING ROLLING

Rail wheels have been produced by axial-radial rolling since 1842. Over the time, efforts have been made to develop the technology further. Unlike simple forming processes, which had been modelled on computers, a number of times, the axial-radial rolling (with the main roll, two forming rolls and conical axial rolls) is very complicated to simulate [11]. This process is now being examined by means of virtual reality methods involving dynamic changes in the course of programming, the so-called LS. Dyna, which can capture changes in geometric nonlinearity, material nonlinearity and contact nonlinearity. In essence, this involves finding dynamic equilibrium conditions, whereupon the process diagram can be used for calculating the state at time t and setting parameters for the time $t+1$. ANSYS software has been used for this purpose.

One of results of this modelling process is shown in Figure 11. The diameter of the wheel processed by ac-

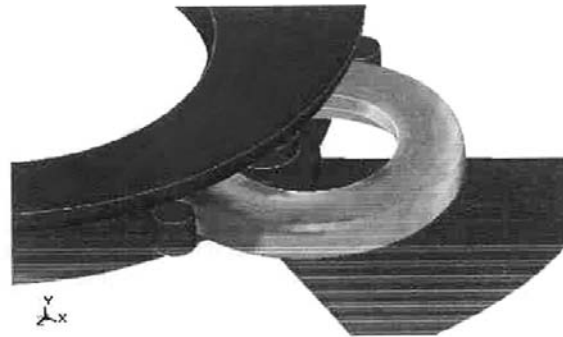

Figure 11 Cut picture of the ring rolls at the final state. [11]

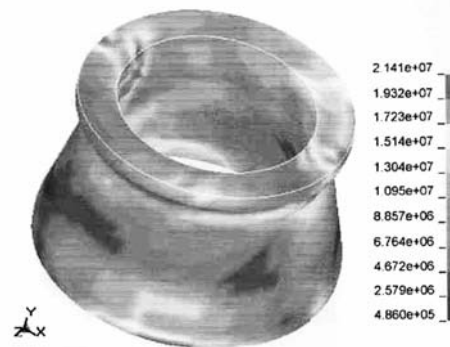

Figure 12 Stress contour of the ring at the final state [11]

tual rolling is 500 mm. Rolling takes place at the temperature of 1 050 °C. During the 30 s cycle of production, the temperature drops by 50 °C. Simulation of another product (from Ti6Al4V) was conducted with the forming temperature of 950 °C. The stress curve at finish-rolling has been recorded see Figure 12. Areas with higher stresses also exhibit high strains. This computer-based method allows the manufacturer to prevent various defects in the actual product.

FABRICATION OF METAL MATRIX COMPOSITES BY METAL INJECTION MOLDING

This is a fairly recent technology for manufacturing complex near-net shape products.

It has a number of variants focused on making materials with very demanding chemical composition. These include the following: production of tungsten and molybdenum which, thanks to their high temperature resistance, have ever increasing importance for high-temperature applications in electronics, aviation industry, telecommunications, medicine and defence [12].

They also include new tungsten-copper alloys with excellent thermal properties (high microwave absorption capacity). This tungsten alloy with 25 % copper is a product of powder metallurgy with 95 % theoretical density upon homogenizing. Other alloys of this type include W-Ni-Fe alloys. Titanium receives attention in re-

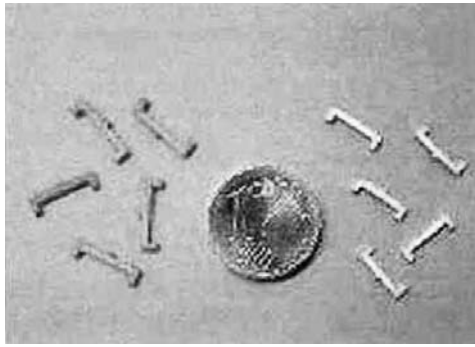

Figure 13 MicroMIMed encoder composited by a non-magnetic steel (316L), interface area about $850\ \mu\text{m} \times 850\ \mu\text{m}$ [12] (Courtesy of Philipp Imgrund, IFAM, Germany)

regard to its compatibility, high chemical stability and excellent properties, which applies to Ti6Al4V and other materials as well. Intermetallic compounds, such as Ni_3Al , have suitable chemical composition for the injection molding process. Metals are processed by the MIM method (Metal Injection Molding). Even steel can be processed by this technique, although conventional forming is much more cost effective. The study was carried out using the 316L steel with TiC or TiN powders. The resulting composite showed excellent hardness-related properties. Unlike conventionally produced steels, this material can meet requirements for very accurate carbon level. Its relative density is between 90 and 99 % of density of steel. The technique can be used for making bimetallic structures where a metallic substrate is coated with steel or another heavy metal cladding. The workpiece used as substrate is made by a forging process and transferred to another device where the bimetallic coating is deposited. The most recent orientation of this method is production of very minute components: the microsystem technology (μMIM) for manufacturing nano and millimetre-sized parts. Micro Metal Injection Molding (μMIM) offers dramatic reduction in mass production costs and production of geometrically complex parts to tight tolerances.

Certain small components of mobile phones are manufactured in the amount of 100 million a year [13]. Figure 13 shown an example product. In this case the μMIM processes not only homogeneous materials but also WC-Co or other composites. This is still an emerging field requiring pure powder materials with uniform grain size.

Acknowledgment

This investigation was conducted with the support of GRANT AGENCY of CZECH REPUBLIC under the project 106/07/0631. Additional support was performed on an instrument developed under the MSM 6198910015 research plan.

REFERENCES

- [1] S. Ch. Yoon, Z. Horita, H. S. Kim, Finite element analysis of plastic deformation behavior during high pressure torsion processing, *Journal of Materials Processing Technology*, 201 (2008), 32-36.
- [2] W. Bochniak, A. Korbel, R. Szyndler, R. Hanarz, F. Stalony-Dobrzański, L. B'az, P. Snarski, New forging method of bevel gears from structural steel, *Journal of Materials Processing Technology*, 173 (2006), 75-83.
- [3] Z. J. Wang, J. G. Liu, X. Y. Wang, Z. Y. Hu, B. Guo, Viscous pressure forming (VPF): state - of - the - art and future trends, *Journal of Materials Processing Technology*, 151 (2004), 80-87.
- [4] M.L.Roades, L.J.Roades, Method and apparatus for die forming sheet material, US Patent 5 085 068 (1992).
- [5] S. John, S. Sikdar, P. K. Swamy, S. Das, B. Maity, Hybrid neural-GA model to predict and minimise flatness value of hot rolled strips, *Journal of Materials Processing Technology*, 195 (2008), 314-320.
- [6] S.R.Schwarz, R.F.Trenty, D.F. Ellerbrock, Terms and definitions on geometrical attributes/profile flatness and surface. In Proc. of Seminar on Cold Strip Mill Profile, Flatness and Surface, Pittsburgh, PA, February, 25-26, p.III-49, 1992.
- [7] S. Lee, Superplastic properties of Pb-62%Sn eutectic alloy after equal channel angular pressing (ECAP), *Journal of Materials Processing Technology*, 201 (2008), 441-444.
- [8] Z. Pater, J. Kazanecki, J. Bartnicki, Three dimensional thermo-mechanical simulation of the tube forming process in Diescher's mill, *Journal of Materials Processing Technology*, 177 (2006), 167-170.
- [9] Z. Pater, A. Gontarz, W. Weroński, Cross-wedge rolling by means of one flat wedge and two shaped rolls, *Journal of Materials Processing Technology*, 177 (2006), 550-554.
- [10] Z. R. Wang, G. Liu, S. J. Yuan, B. G. Teng, Z. B. He, Progress in shell hydroforming, *Journal of Materials Processing Technology*, 167 (2005), 230-236.
- [11] Z. W. Wang, S. Q. Zeng, X. H. Yang, C. Cheng, The key technology and realization of virtual ring rolling, *Journal of Materials Processing Technology*, 182 (2007), 374-381.
- [12] H. Ye, X. Y. Liu, H. Hong, Fabrication of metal matrix composites by metal injection molding-A review, *Journal of Materials Processing Technology*, 200 (2008), 12-24.
- [13] J.L.Johnson, R.M.German, PIM Materials, *Advanced Material Processing*, 161 (4), 35-39.

Note. The responsible translator for English language is J. Drnek, Czech Republic.