

PARAMETRIC ANALYSIS OF WIND ACTION ON SLAB BRIDGE DECK

Ivana ŠTIMAC GRANDIĆ – Ana IVANČIĆ – Bojan LIKER

Abstract: *In this paper, the parametric analysis of wind action on the bridge deck is conducted. Wind force acting on the bridge deck is calculated varying upon the following parameters: wind area, terrain category, road restraint system and height of the deck above ground. The presented results show the possibility of great changes in wind force due to changes of the listed parameters. Since a similar slab bridge deck is often used in different locations in Croatia, it is important to bear in mind when designing standardised bridges the fact that the wind load on bridges in different locations can change several times.*

Keywords: – wind action
– parametric analysis
– EN 1991-1-4

1. INTRODUCTION

Wind action, besides earthquake, makes up the dominant horizontal effect on structures in their lifetime. In particular, the significance of these actions, which are variable in time and in intensity, varies depending on the meteorological and seismological characteristics of a certain area.

In the design of dynamically sensitive structures (e.g. suspension bridges [1]), whose behavior depends on the dynamic motion of the structure and the dynamic character of the load, it is necessary to carry out the calculation of the dynamic response of structures by using the dynamic response procedure, such as modal analysis. Wind load on the dynamic insensitive structure can be treated as quasi-static, so a dynamic response procedure is not needed. Technical regulations, aimed at ensuring conditions for joining the common European market, taking into account the principles of the European harmonization of technical legislation [2-6], refer to a series of European standards for design (Eurocodes) which ensure the fulfillment of the essential requirements for building according to Construction Product Directive [7]. These European standards are adopted as the Croatian standard (HR EN). Wind load on structures is defined by standard EN 1991-1-4 [8] and associated National Annex.

In the past decade, several papers dealing with the problem of determining the nationally defined

parameters for the modelling of wind load in Croatia were published [9-12]. Due to the fact that the National Annexes are still under revision, in this paper the National Annex for the draft standard ENV [13] will be used because huge changes in the National Annex for standard EN 1991-1-4 are not expected.

2. WIND ACTIONS ACCORDING TO EN 1991-1-4

2.1. General

EN 1991-1-4 gives guidance on the determination of natural wind actions for the structural design of building and civil engineering works for each of the loaded areas under consideration. This includes the whole structure or parts of the structure or elements attached to the structure. This standard is applicable to bridges with a span of up to 200 m, with the exception of cable supported bridges.

The wind action is represented by a simplified set of pressures or forces whose effects are equivalent to the extreme effects of the turbulent wind. In general, wind pressure on the structure or structural element acts perpendicular to the surface, except where otherwise provided, for example, in the tangential friction force on the bridge deck surface. The wind actions calculated using EN 1991-1-4 [8] are

characteristic values determined from the basic values of wind velocity or the velocity pressure.

2.2. Wind action on bridges

According to the standard EN 1991-1-4 [8], a dynamic response procedure is generally not needed for normal road and railway bridge decks of less than a 40 m span, bridges of a constant depth consisting of a single deck with one or more spans. For the purpose of this categorization, normal bridges are bridges constructed in steel, concrete, aluminum or timber, including composite construction, and whose shape of cross sections is generally covered by Figure 1.

Wind actions on bridges produce forces in the three directions as shown in Figure 2 where the x-direction is the direction parallel to the deck width, perpendicular to the span, the y-direction is the direction along the span and the z-direction is the direction perpendicular to the deck. L is length in the y-direction, b is the width in the x-direction and d is the depth in the z-direction.

The dominant component of the wind action on the bridge is the force in the x-direction [14], therefore only that component will be analyzed in this paper.

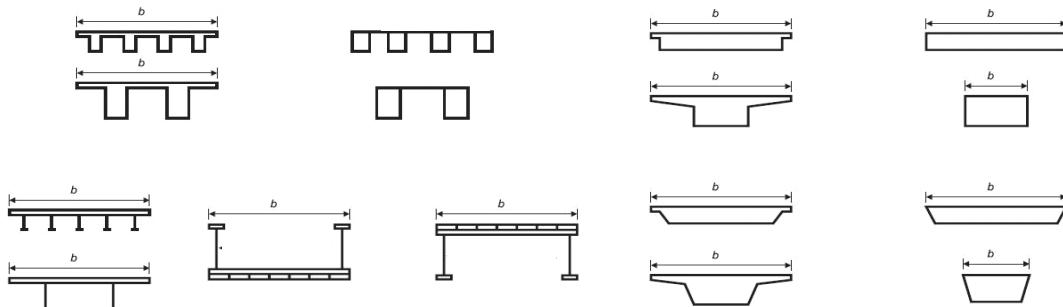

Figure 1. Cross-sections of normal construction decks [8]

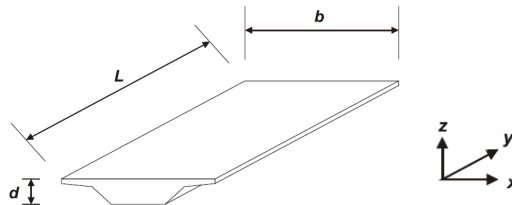

Figure 2. Directions of wind actions on bridges

2.2.1. Wind force in x-direction

Where it has been assessed that a dynamic response procedure is not necessary, the wind force in the x-direction may be obtained using the Equation (1)

$$F_w = \frac{1}{2} \cdot \rho \cdot v_b^2 \cdot C \cdot A_{ref,x} \quad (1)$$

where:

ρ is the density of air,

v_b is the basic wind velocity,

C is the wind load factor for bridges,

$A_{ref,x}$ is the reference area.

The values for ρ may be given by the National Annex, while the recommended value is $1,25 \text{ kg/m}^3$.

The basic wind velocity is defined as:

$$v_b = c_{dir} \cdot c_{season} \cdot v_{b,0} \quad (2)$$

where:

c_{dir} is the directional factor (various wind directions may be found in the National Annex; the recommended value is 1,0),

c_{season} is the seasonal factor (may be given in the National Annex; the recommended value is 1,0),

$v_{b,0}$ is the fundamental value of the basic wind velocity defined as the characteristic 10 minutes mean wind velocity at 10 m above ground of terrain category II.

The wind load factor C is determined by the following equation:

$$C = c_e(z) \cdot c_{f,x} \quad (3)$$

where:

$c_e(z)$ is the exposure factor,

$c_{f,x}$ is the force coefficients in the x-direction.

Force coefficient for wind actions on bridge decks in the x-direction is given by:

$$c_{f,x} = c_{fx,0} \quad (4)$$

where:

$c_{fx,0}$ is the force coefficient without free-end flow.

For normal bridges $c_{fx,0}$ may be taken equal to 1,3.

Alternatively, $c_{fx,0}$ may be taken from Figure 3.

For a flat terrain, where the orography factor $c_o(z)=1,0$, the exposure factor $c_e(z)$ can be determined from Figure 4. It is a function of height above ground level and a function of terrain category.

The standard EN 1991-1-4 [8] defines five different terrain categories:

0 - sea or coastal area exposed to the open sea,

I - lakes or flat and horizontal area with negligible vegetation and without obstacles,

II - area with low vegetation such as grass and isolated obstacles (trees, buildings) with separations of at least 20 obstacle heights,

III - area with regular cover of vegetation or buildings or with isolated obstacles with separations of a maximum of 20 obstacle heights (such as villages, suburban terrain, permanent forest), IV - area in which at least 15% of the surface is covered with buildings and their average height exceeds 15 m.

The reference area $A_{ref,x}$ for decks with plain beams or webs without traffic should be defined as:

$$A_{ref,x} = d_{tot} \cdot L \quad (5)$$

where $d_{tot} = d + d_1$ is defined according to Figure 5 and Table 1; L is length of a span of the bridge deck.

3. PARAMETRIC ANALYSIS

In the paper, the effect of wind on the slab beam bridge deck shown in Figure 6 is analyzed. This type of bridge deck is very usual, so similar deck structures can be found at various locations in Croatia, in different environments, and at different heights above ground level. Also, different types of road restraint system can be built on it. All these parameters affect the wind load on the deck. Therefore, in this paper, parametric analysis of wind load on a slab beam bridge deck as shown in Figure 6 will be conducted varying the road restraint system (open parapet for pedestrians, a solid concrete safety barrier height of 1.1 m and an open parapet for pedestrians together with an open safety barrier), the height of deck above ground level (5, 10, 15 and 20 m), the terrain category (0 to IV) and differing wind area (I to V).

3.1. Defining the parameters for the calculation

To calculate the wind load on the bridge deck in accordance with Equation (1), it is necessary to determine the following parameters: the density of air ρ , the basic wind velocity v_b , the wind load factor C and the reference area $A_{ref,x}$.

3.1.1. The density of air

Recommended value $\rho = 1,25 \text{ kg/m}^3$ is taken into account [13].

3.1.2. The basic wind velocity

The basic wind velocity is determined according to Equation (2). The directional factor $c_{dir} = 1$ and the season factor $c_{season} = 1$ [13].

The fundamental value of the basic wind velocity $v_{b,0}$ is defined in the National Annex [13]. According to [13], Croatia is divided into five wind areas, as shown in Figure 7.

3.1.3. The wind load factor

The force coefficient is defined by Equations (3) and (4) in Chapter 2.2.1.

The force coefficient $c_{f,x}$ is shown in Table 2, in dependence of the road restraint system, depth and width of the deck. The exposure factor $c_e(z)$ is shown in Table 3, in dependence on the deck height above ground and the terrain category.

Values d , d_1 , d_{tot} and b are determined according to Figure 6 and Table 1. Terrain categories A, B and C

are defined in Table 1. The values of c_{fx} are determined from Figure 3 and $c_e(z)$ from Figure 4.

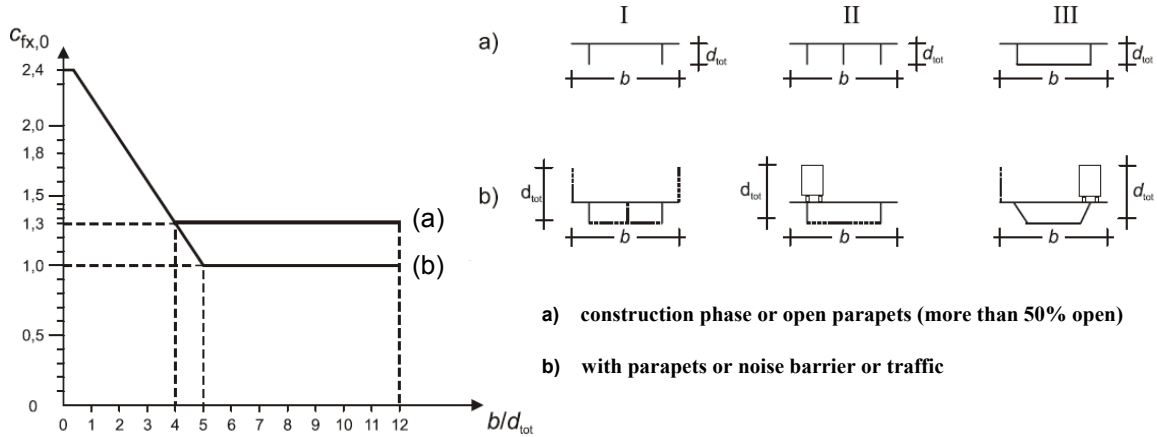

Figure 3. Force coefficient $c_{f,x}$ for bridges [8]

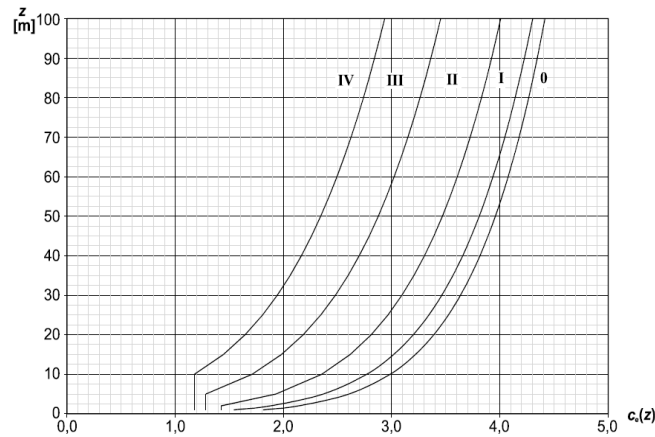

Figure 4. Illustrations of the exposure factor $c_e(z)$ for $c_o(z)=1,0$ [8]

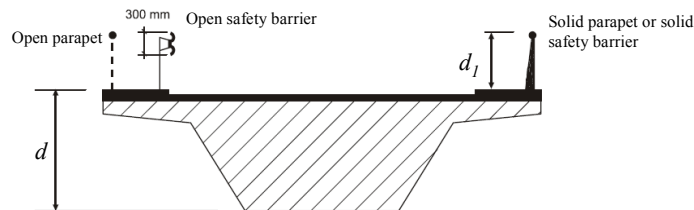

Figure 5. Depth to be used for $A_{ref,x}$ [8]

Table 1. Depth d_{tot} to be used for $A_{ref,x}$

Road restraint system		on one side	on both sides
Open parapet or open safety barrier	A	$d+0,3 m$	$d+0,6 m$
Open parapet and open safety barrier	B	$d+0,6 m$	$d+1,2 m$
Solid parapet or solid safety barrier	C	$d+d_1$	$d+2 d_1$

3.1.4. The reference area

The reference area is defined by Equation (5), where L is 14,5 m and the values of d_{tot} are shown in Table 2.

3.2. Results

The results of the obtained parametric analysis are shown in Tables 4 to 8. The wind force F_w acting on the bridge deck in the x-direction is calculated by using Equation (1) and varying the following parameters: height of the bridge deck above ground, the terrain category, the road restraint system and the wind area.

Some typical results are graphically shown in Figures 8 to 10.

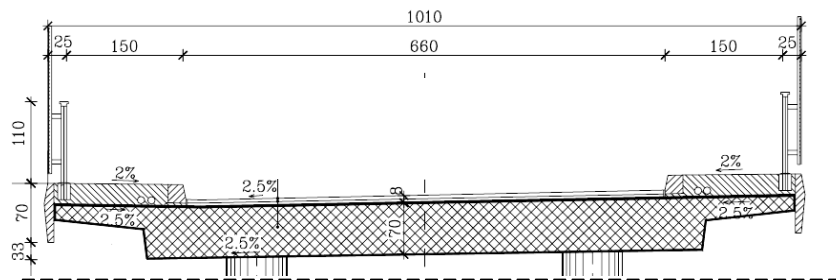

Figure 6. Analyzed bridge deck cross section

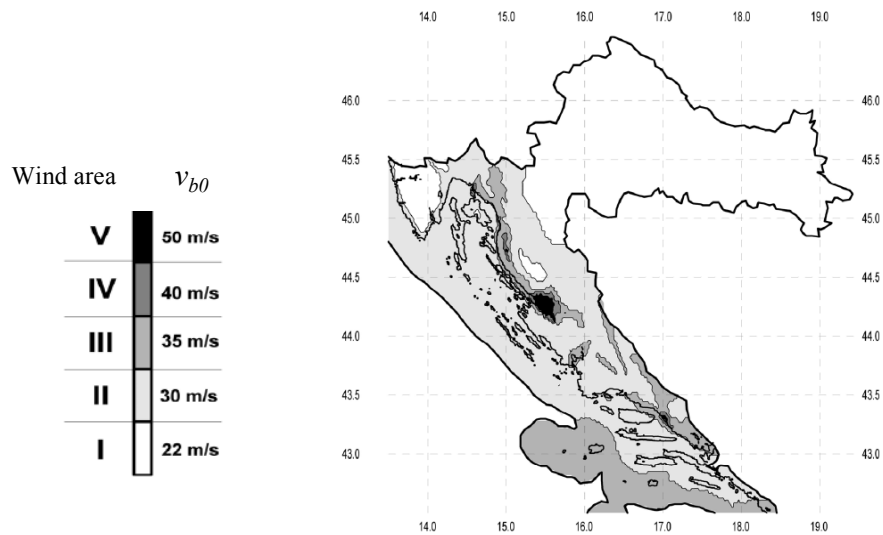

Figure 7. A graphic representation of wind areas in Croatia and the corresponding fundamental value of the basic wind velocity

Table 2. The force coefficient $c_{f,x}$ in dependence on road restraint system and deck dimensions

Road restraint system	d [m]	d_l [m]	d_{tot} [m]	b [m]	b/d_{tot}	$c_{f,x}$
A	1,03	0,6	1,63	10,1	6,20	1,3
B		1,2	2,23		4,53	1,15
C		2,2	3,23		3,13	1,6

Table 3. The exposure coefficient $c_e(z)$ in dependence on height above ground and terrain category

$c_e(z)$		Terrain category				
		0	I	II	III	IV
Height above ground	5 m	2,6	2,32	1,9	1,3	1,19
	10 m	3,0	2,75	2,35	1,7	1,19
	15 m	3,2	3,0	2,6	2,0	1,45
	20 m	3,4	3,2	2,8	2,2	1,65

Table 4. The wind force for I wind area

F_w [kN]			Height above ground				
			5 m	10 m	15 m	20 m	
Terrain category	0	Road restraint system	A	24,22	27,84	29,73	31,61
			B	29,29	33,79	35,96	38,28
			C	58,87	68,01	72,50	77,14
	I		A	21,61	25,52	27,84	29,73
			B	26,10	30,89	33,79	35,96
			C	52,64	62,35	68,01	72,50
	II		A	17,69	21,90	24,22	25,96
			B	21,32	26,39	29,29	31,47
			C	43,07	53,22	58,87	63,51
	III		A	12,04	15,81	18,56	20,45
			B	14,65	19,14	22,48	24,80
			C	29,44	38,57	45,39	49,88
IV	A	11,02	11,02	13,49	15,37		
	B	13,34	13,34	16,24	18,56		
	C	26,97	26,97	32,92	37,41		

Table 5. The wind force for II wind area

F_w [kN]			Height above ground				
			5 m	10 m	15 m	20 m	
Terrain category	0	Road restraint system	A	44,95	51,91	55,25	58,73
			B	54,38	62,79	66,99	71,05
			C	109,62	126,44	134,85	143,26
	I		A	40,17	47,56	51,91	55,25
			B	48,58	57,57	62,79	66,99
			C	97,73	115,86	126,44	134,85
	II		A	32,77	40,60	44,95	48,43
			B	39,73	49,16	54,38	58,58
			C	80,04	99,04	109,62	118,03
	III		A	22,48	29,44	34,51	37,99
			B	27,26	35,53	41,91	45,97
			C	54,81	71,63	84,25	92,80
IV	A	20,59	20,59	25,09	28,57		
	B	24,94	24,94	30,31	34,51		
	C	50,17	50,17	61,19	69,60		

Table 6. The wind force for III wind area

		F_w [kN]		Height above ground			
				5 m	10 m	15 m	20 m
Terrain category	0	Road restraint system	A	61,19	70,62	75,26	80,04
			B	73,95	85,41	91,06	96,86
			C	149,21	172,12	183,57	195,03
	I		A	54,52	64,67	70,62	75,26
			B	66,12	78,30	85,41	91,06
			C	133,11	157,76	172,12	183,57
	II		A	44,66	55,25	61,19	65,83
			B	54,09	66,85	73,95	79,75
			C	109,04	134,85	149,21	160,66
	III		A	30,60	40,02	46,98	51,77
			B	36,98	48,43	56,99	62,64
			C	74,53	97,59	114,70	126,15
IV	A	27,99	27,99	34,08	38,86		
	B	33,93	33,93	41,33	46,98		
	C	68,30	68,30	83,23	94,69		

Table 7. The wind force for IV wind area

		F_w [kN]		Height above ground			
				5 m	10 m	15 m	20 m
Terrain category	0	Road restraint system	A	79,90	92,22	98,31	104,40
			B	96,72	111,51	119,05	126,44
			C	194,88	224,75	239,83	254,77
	I		A	71,34	84,54	92,22	98,31
			B	86,28	102,23	111,51	119,05
			C	173,86	206,05	224,75	239,83
	II		A	58,44	72,21	79,90	85,99
			B	70,62	87,44	96,72	104,11
			C	142,39	176,03	194,88	209,82
	III		A	39,88	52,20	61,48	67,57
			B	48,29	63,22	74,39	81,78
			C	97,44	127,46	149,93	164,87
IV	A	36,54	36,54	44,52	50,75		
	B	44,23	44,23	53,94	61,34		
	C	89,18	89,18	108,61	123,69		

Table 8. The wind force for V wind area

		F_w [kN]		Height above ground			
				5 m	10 m	15 m	20 m
Terrain category	0	Road restraint system	A	124,85	143,99	153,70	163,27
			B	151,09	174,29	185,89	197,49
			C	304,50	351,34	374,68	398,17
	I		A	111,36	132,10	143,99	153,70
			B	134,85	159,79	174,29	185,89
			C	271,59	322,05	351,34	374,68
	II		A	91,21	112,81	124,85	134,42
			B	110,35	136,59	151,09	162,69
			C	222,43	275,21	304,50	327,85
	III		A	62,35	81,64	95,99	105,56
			B	75,55	98,75	116,15	127,89
			C	152,25	199,09	234,18	257,67
IV	A	57,13	57,13	69,60	79,17		
	B	69,17	69,17	84,25	95,85		
	C	139,35	139,35	169,80	193,14		

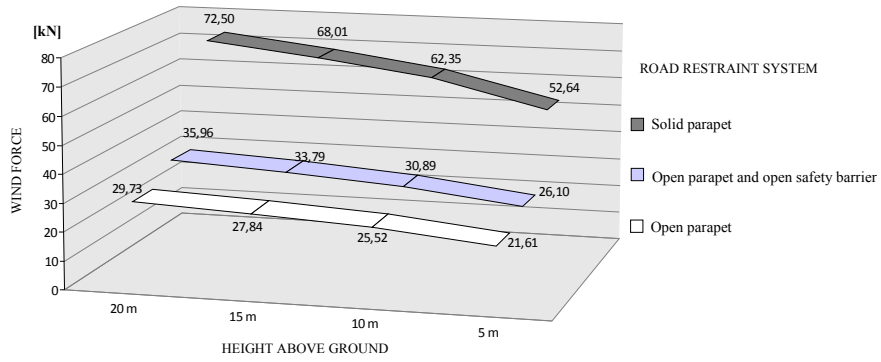

Figure 8. The wind force in I wind area and terrain category I, in dependance on height above ground and road restraint system

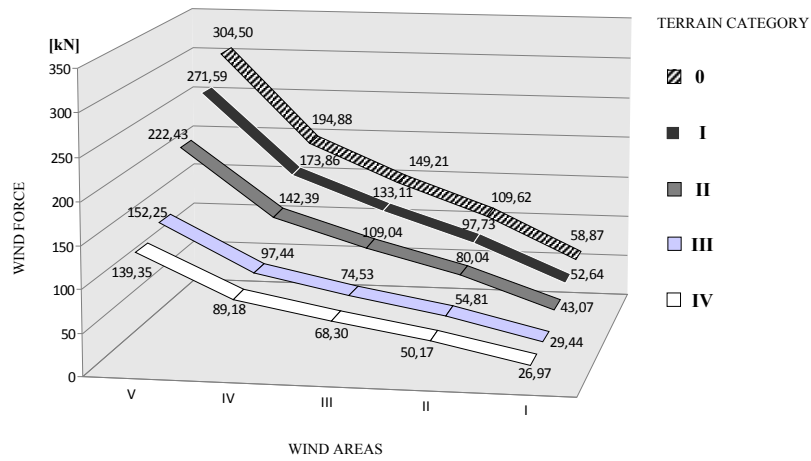

Figure 9. The wind force on 5 m of height above ground and with solid parapet, in dependance on wind area and terrain category

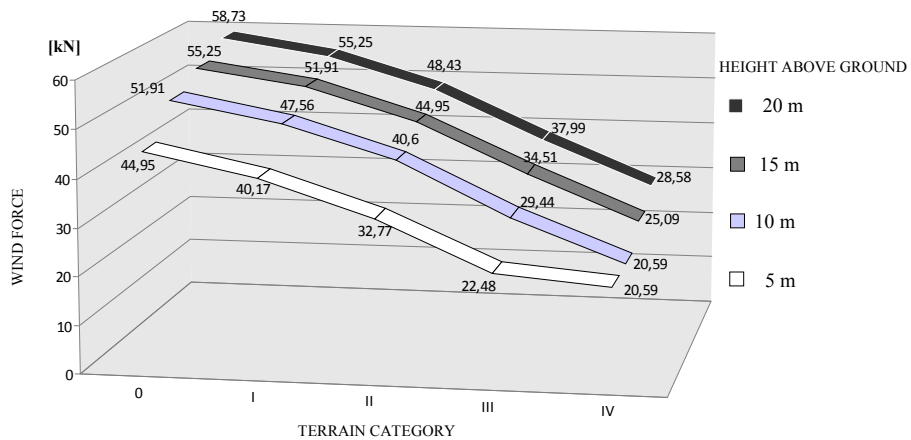

Figure 10. The wind force in II wind area and with open parapet, in dependance on terrain category and height above ground

4. CONCLUSION

From the analysis of the results obtained in this study we can conclude the following:

1. The wind force acting on the deck of the analyzed bridge, which is built in the same terrain category on the same height above ground, with the same road restraint system, but in a different wind area, increases with increasing wind area (in the I wind area the force is the smallest and in the V wind area the force is the greatest). The wind force increases due to an increase in the basic wind velocity. The ratio of wind forces for a certain wind area is a square function of the ratio of their basic wind velocities.

2. The wind force acting on the deck of the analyzed bridge, which is built in the same wind area, on the same height above ground, with the same road restraint system, but on the different terrain category, decreases with increasing a terrain category (on the terrain category 0 (coastal area exposed to the open sea) the force is the greatest and on the terrain category IV (in cities) it is the smallest). The maximum value of wind force can be twice as high as the minimum value for the same bridge.

3. With the wind force acting on the deck of the analyzed bridge, which is built in the same wind area and on the same terrain category, the same road restraint system increases due to an increase in the height of the deck above ground. The wind force on the deck at 20 m above ground is 30-40% greater than on the deck at 5 m above ground.

4. The wind force acting on the deck of the analyzed bridge, which is built in same wind area on the same bridge deck height above ground on the same terrain category, is different for different road restraint systems. The smallest force acts on the bridge with an open pedestrian parapet. The force increases by 20% if there is an open safety barrier besides an open pedestrian parapet, and the greatest force is on the bridge with a solid concrete parapet. The greatest force is 2.4 times greater than the minimal force; the choice of open fences instead of a concrete solid parapet on the same bridge can reduce the wind force by more than double.

If we look closer at the results of parametric analysis, it can be seen that the smallest wind force ($F_w = 11,02$ kN) is calculated for a bridge built in the I wind area, on the terrain category IV with a bridge deck at 5 or 10 m above ground and with an open parapet (for instance a bridge built in the city

of Osijek). The greatest wind force ($F_w = 398,17$ kN) is calculated for a bridge built in the V wind area, on the terrain category I, with a bridge deck at 20 m above ground and with a solid parapet (for instance a bridge built in the coastal area of the Makarska region). As it can be seen from the analysis, wind action on a bridge deck may change drastically due to the wind area, terrain category, road restraint system and bridge deck height above ground. These facts must be taken into account when standardized bridges are built in different locations.

5. LIST OF SYMBOLS

wind force	F_w , kN
density of air	ρ , kg/m ³
basic wind velocity	v_b , m/s
wind load factor	C , -
reference area	$A_{ref,x}$, m ²
directional factor	C_{dir} , -
season factor	C_{season} , -
fundamental value of the basic wind velocity	$v_{b,0}$, m/s
exposure factor	$c_e(z)$, -
orography factor	$c_o(z)$, -
force coefficients	$C_{f,x}$, -
force coefficient without free-end flow	$C_{fx,0}$, -
calculating depth	d_{tot} , m
length of a span	L , m
width of a span deck	b , m

REFERENCES

- [1] Čaušević, M., Špalj, I., Žic, E.: *Djelovanje vjetra na mostove prema europskoj normi*, Građevinar, Vol. 60 (2008) No. 1, p. 21-35.
- [2] *Tehnički propis za betonske konstrukcije*; Narodne novine br. 139/09, 14/10 i 125/10
- [3] *Tehnički propis za zidane konstrukcije*; Narodne novine br. 1/07
- [4] *Tehnički propis za drvene konstrukcije*; Narodne novine br. 121/07, 48/2009 i 125/10
- [5] *Tehnički propis za čelične konstrukcije*; Narodne novine br. 112/08 i 1125/10
- [6] *Tehnički propis za spregnute konstrukcije od čelika i betona*; Narodne novine br. 119/09 i 125/10
- [7] *Council Directive 89/106/EEC on 21 December 1988 on the approximation of laws, regulations and administrative provisions of the Member*

- States relating to construction products*, Official Journal L 040, 11/02/1989
- [8] *EN 1991-1-4, Eurocode 1 – Actions on structures: Part 1-4: General actions – Wind actions*, CEN, Bruxelles, 2005.
- [9] Peroš, B., Boko, I., Šimunović, T., Kuzmanić, D.: *Podloge za nove hrvatske norme za opterećenje vjetrom*, Građevinar, Vol. 60 (2008) No. 4, p. 309-316.
- [10] Bajić, A.: *Očekivani režim strujanja vjetra na autocesti Sv. Rok (jug) – Maslenica*, Građevinar, Vol. 55 (2003) No. 3, p. 149-158.
- [11] Bajić, A., Peroš, B., Vučetić, V., Z. Žibrat, Z.: *Opterećenje vjetrom – meteorološka podloga za hrvatske norme*, Građevinar, Vol. 53 (2001) No. 8, p. 495-505.
- [12] Bajić, A., Peroš, B.: *Referentna brzina vjetra – utjecaj perioda osrednjavanja*, Građevinar, Vol. 53 (2001) No. 9, p. 555-562.
- [13] *HRN ENV 1991-2-4, Eurokod1: Osnove projektiranja i djelovanja na konstrukcije - 2-4. dio: Djelovanja na konstrukcije - Opterećenje vjetrom*, Hrvatski zavod za norme, Zagreb, 2005.
- [14] Liker, B.: *Opterećenje vjetrom rasponskog sklopa cestovnog mosta u ovisnosti o kategoriji zemljišta prema EN 1991-1-4*, Završni rad, Rijeka, 2009.

Received: 10.02.2011.

Accepted: 16.05.2011.

Preliminary note

Authors' address

doc.dr.sc. Ivana Štimac Grandić, dipl.ing.grad.

Ana Ivančić, univ. bacc. ing. aedif.

Bojan Liker, univ. bacc. ing. aedif.

Građevinski fakultet Sveučilišta u Rijeci

Viktora Cara Emina 5

51000 Rijeka

HRVATSKA

ivana.stimac@gradri.hr

ana.ivancic@gradri.hr

bojan.likier@gradri.hr