

# Somatosensory Vibratory Evoked Potentials: Stimulation Parameters

UDK 612.843:681.586  
IFAC 5.9.2

Original scientific paper

In a clinical application, a method for an examination of a vibratory sense is not very objective and it depends on an active cooperation of a patient, which cannot be achieved in every situation. The aim of this research is to define parameters of an evoked potentials method with a vibratory stimulation technique which would establish reliable and repeatable results applicable in a clinical usage. During the research, different experimental conditions were performed (different methods of stimulation, different stimulation frequencies, different stimulus durations, different areas of stimulation). Presented results confirm the initial assumption that it is possible to detect reliable and repeatable cortical potentials evoked by the vibratory stimulation. Characteristic shapes and spatiotemporal distributions of evoked responses are established. Optimal stimulation parameters are defined as a prelude for a future research.

**Key words:** Evoked potentials, Frequency, Somatosensory evoked potentials, Vibratory stimulation

**Somatosenzorni evocirani potencijali pobuđeni vibracijskom stimulacijom: parametri stimulacije.** U kliničkoj uporabi, metoda ispitivanja dubokog osjeta pomoću vibracija nije objektivna i zahtijeva aktivnu suradnju pacijenta što u brojnim situacijama nije moguće. Svrha ovog istraživanja je definirati parametre metode evociranih potencijala pobuđenih vibracijskom stimulacijom primjenjive u kliničkoj uporabi, koja će davati pouzdane i ponovljive rezultate. Tijekom ispitivanja, primijenjeni su različiti eksperimentalni uvjeti (različite tehnike stimulacije, različite frekvencije stimulacije, različita trajanja stimulacije, različita područja stimuliranja). Rezultati potvrđuju početnu pretpostavku da je moguće detektirati pouzdane i ponovljive kortikalne potencijale pobuđene vibracijskom stimulacijom. Utvrđeni su karakteristični valni oblici evociranih odgovora i njihove prostorno-vremenske karakteristike. Optimalni stimulacijski parametri su definirani kao podloga za buduća istraživanja.

**Ključne riječi:** evocirani potencijali, frekvencija, somatosenzorni evocirani potencijali, vibracijska stimulacija

## 1 INTRODUCTION

In medicine, there are different methods to determinate a deep sense in a patient. One of the methods verifies the deep sense with a vibratory stimulation. In this method, a vibratory fork is reclined to a patient's wrist and a patient expresses his/her subjective sense of vibrations. The disadvantage of this method is a lack of objectivity and dependence on an active cooperation of the patient. The usage of this method is impossible with patients in a coma, patients who are not able to communicate or with small children.

The aim of this research is to improve the method by exploring the connection between evoked potentials and the deep sense of the vibration. Evoked potentials (EP) are neural responses associated with specific sensory, cognitive and motor events [1]. The method of evoked potentials is a noninvasive diagnostic method very useful in many scientific and clinical applications. Evoked potentials considered in this research are somatosensory evoked poten-

tials. Somatosensory evoked potentials (SEPs) consist of a series of waves that reflect sequential activation of neural structures along the somatosensory pathways following a peripheral stimulation [2]. Clinical studies use a mechanical or an electrical stimulation of peripheral nerves. In this research the vibratory stimulation was used in order to get specific cerebral responses.

Many authors have already worked with frequency domain measurements of vibrotactile responses in different kinds of afferents [3,4]. Their work provides detailed insight in the area of the sensory neurophysiology related to the vibrotactile stimulation.

Receptors specific for the sense of the vibrations are mechanoreceptors. These are sensory receptors that respond to mechanical pressure, stretching or distortion. There are different types of mechanoreceptors, depending on their ability to interpret velocity, severity and directionality of stimuli. Receptors of interest for this research are

Pacinian corpuscles and Meissner's corpuscles. Pacinian corpuscles are rapidly adapting receptors that sense vibratory stimuli and touch and they are most sensitive to vibrations of about 200 – 300 Hz [5]. Meissner's corpuscles sense best around 50 Hz. In frequency range of about 100 Hz, both receptors are involved and according to [6] the frequency of 100 Hz is adequate for stimulating changes in a human neural system. In this research, according to different results achieved in other researches in this field, one of the goals was to determine the vibration frequency optimal for inducing somatosensory vibratory potentials.

Münste et al. [7] in their experiment obtained an activity contralateral to a stimulated arm in the central sulcus followed by a negativity symmetrically distributed over frontocentral regions. The duration of their stimulation was 1000 ms. Due to a relatively huge number of stimulations necessary to evoke a visible vibratory somatosensory potential, effects of different stimulus durations were investigated in our research.

In [7] the area of stimulation was forearm. Snyder [8] stimulated fingers and a palmar surface with an amplitude modulated vibration. In clinical use, stimulation areas for somatosensory evoked potentials are nerves at a wrist and an ankle. One of the goals of our research was to find an optimal stimulation area for the vibratory stimulation.

The aim of our research was to find optimal parameters (technique, frequency, duration and place of stimulation) for achieving a clinically useful, reliable and applicable method for somatosensory vibratory potentials.

## 2 MATERIALS AND METHODS

In order to examine cerebral dynamics that occurs as a result of a vibratory stimulation, experiments with different experimental conditions were performed.

Experiments were performed with different areas of stimulation (wrist, ankle, clavicle, finger, elbow), different frequencies of stimulation (30 Hz, 60 Hz, 128 Hz, 256 Hz, 496 Hz), different durations of stimulation (100 ms, 200 ms, 300 ms, 600 ms, 1000 ms) and different ways of stimulus application (constant frequency, change in frequency).

The experiments were performed in the Laboratory for Psycholinguistic research, Interdisciplinary Scientific Postgraduate Study Language and Cognitive Neuroscience, University of Zagreb.

Participants that participated in the experiment are ten males and three females. They do not suffer from any known neurological or other illness. Participants range in age from 20 to 26 (mean 23.07 +/- 1.38). They are all right handed. The experiment was explained to them in details and they all signed an informed consent form.

Research has lasted for a longer time period and in specific periods during that time stimulations with specific characteristics were performed.

Participants sat in a comfortable chair with their eyes closed. During the experiment they were instructed to minimize eye blinking and body movements as much as possible in order to avoid artifacts. There were sets of various measurements. After each measurement there was a break in which participants could rest in order to minimize participants' fatigue and to keep participants' alertness.

Figure 1 presents a measurement scheme. A vibratory stimulator was used to obtain stimuli. The stimulator was controlled by the software E-Prime [Psychology Software Tools, USA]. It is the software for creating experimental designs, for data collection with a millisecond precision and for data analysis. E-Prime was connected to the QuickAmp amplifier and it sent a signal which marked the beginning of the stimulation. QuickAmp [Brain Products GmbH, Germany] is 136-channel system for recording of EEG and various peripheral signals. QuickAmp collected signals from 32 EEG channels and from two bipolar channels for horizontal and vertical eye movement. It was connected with the electrode cap actiCap [Brain Products GmbH, Germany]. ActiCap with its active electrode system enables low electrode-skin impedance and a fast electrode placement. Electrodes were placed according to the International 10-20 system plus additional channels. The monopolar recording was performed toward the reference electrode embedded in the actiCap. The electrode impedance of less than 20 kOhm was adjusted using an electrically high conductive gel. EEG signals were filtered with a pass band filter with a low-cutoff frequency set to 0.1 Hz and with a high-cutoff frequency set to 150 Hz. The sample rate frequency was 2000 Hz. The software for recording data was Brain Vision Recorder [Brain Products GmbH, Germany].

The analysis of collected data was performed off-line after each experiment. The software for data analysis was

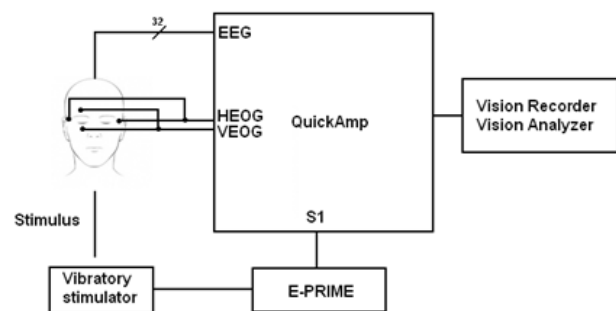

Fig. 1. The measurement scheme

Brain Vision Analyzer [Brain Products GmbH, Germany]. The analysis was performed on segments of 1500 ms, 500 ms before the stimulus onset and 1000 ms after the stimulus onset. The ERP baseline was determined as the average of all samples from the first 500 ms period in the segment. A computerized semiautomatic ocular correction (max/min amplitude  $\pm 200 \mu\text{V}$ ) and an artifact rejection (max/min amplitude  $\pm 80 \mu\text{V}$ ) were made in order to reject trials in which blinks or artifacts occurred. After that, trials were averaged and filtered with a 30 Hz high-cutoff filter. The grand average was computed from all individuals' analyzed data.

## 2.1 Stimulation

For presented experiments we have used different types of stimulating devices. We started by using a Joystick vibrator because of its easy computer control, but an onset and an offset of a vibration turned up to be too variable in relation to a synchronization trigger signal sent to an averaging device. Then we used a vibrator taken out of a mobile phone, but its shape did not allow it to be applied against intended stimulating sites of the body. Later, we used an electronic tooth brush and made a control unit to control its predefined vibration possibilities. We were able to control a frequency choice of 256 or 496 Hz and stimulus duration. The next step was modifying its electronic controller by a custom made electronics to gain a possibility to use more stimulating frequencies, 30, 60, 128 and 256 Hz. These frequencies cover almost the whole sensible range of vibratory receptors. The stimulation was performed by a tangential application of the stimulator vibratory stick. Its displacement on a stimulating site was  $\pm 0.5 \text{ mm}$  and a stimulated surface was approximately  $10 \text{ mm}^2$ . A stimulator frequency characteristic measured for the stimulating frequency of 256 Hz shows that higher frequency harmonics are less inherent so that the stimulation can be assumed to be sinusoidal, as shown on Fig. 2.

In order to control the stimulation and stimulation parameters the script for the E-Prime software was written. It defines the stimulation frequency, the stimulus frequency and the stimulus duration as well as synchronization with the evoked potentials averaging device. The interface between E-Prime and the stimulator has a galvanic isolation to satisfy a patient's safety requirements.

In spite of good stimulator characteristics, during its application we realized that there are still some issues. It would be better instead of a tangential to use a perpendicular stimulation. Also, the problem seems to be a displacement of a patient stimulating site against the stimulator, causing changes in an applied stimulating intensity during the examination. Therefore, the improvement of the stimulator construction is still a continuous process.

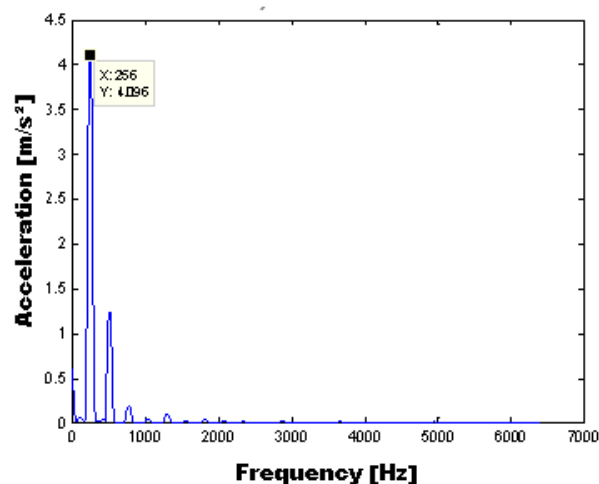

Fig. 2. Stimulator frequency characteristic at 256 Hz vibration

All results presented in the following section are obtained with the last version of the vibratory stimulator previously described in this section with the stimulation frequency of 128 Hz.

## 3 RESULTS

Evoked potentials obtained in experiments in which a left and a right ankle were vibrated for 300 ms (with a 128 Hz frequency) show almost the same spatiotemporal distribution. The most pronounced activity is obtained from electrodes Cz, FC1 and FC2. Spatiotemporal maps reveal a positive activity with a wide central, frontocentral and centroparietal distribution. A maximum activity occurs around 300-350 ms, which is a period following a termination of a vibratory stimulation.

A spatiotemporal distribution of evoked potentials is presented on Fig. 3 and Fig. 4 in a period between 0 ms (a moment in which the vibratory stimulus starts) and 1000 ms by means of 40 maps. Maps represent a top view of a head with an angle of  $75^\circ$ . Every map presents an average value of evoked potentials in a period of 25 ms. Blue areas represent a negative activity and red areas represent a positive activity.

It can be perceived that the first activity induced by the vibratory stimulation of the left and the right ankle occurs in the left frontocentral area. We can associate this with the fact that all participants are right-handed, which means that this activity occurs in a dominant left hemisphere. The first activity in the right hemisphere in case of the left ankle stimulation occurs around 250 ms. In this period there is also a negative activity occurring in the left hemisphere as a result of the right ankle stimulation, hence we can consider

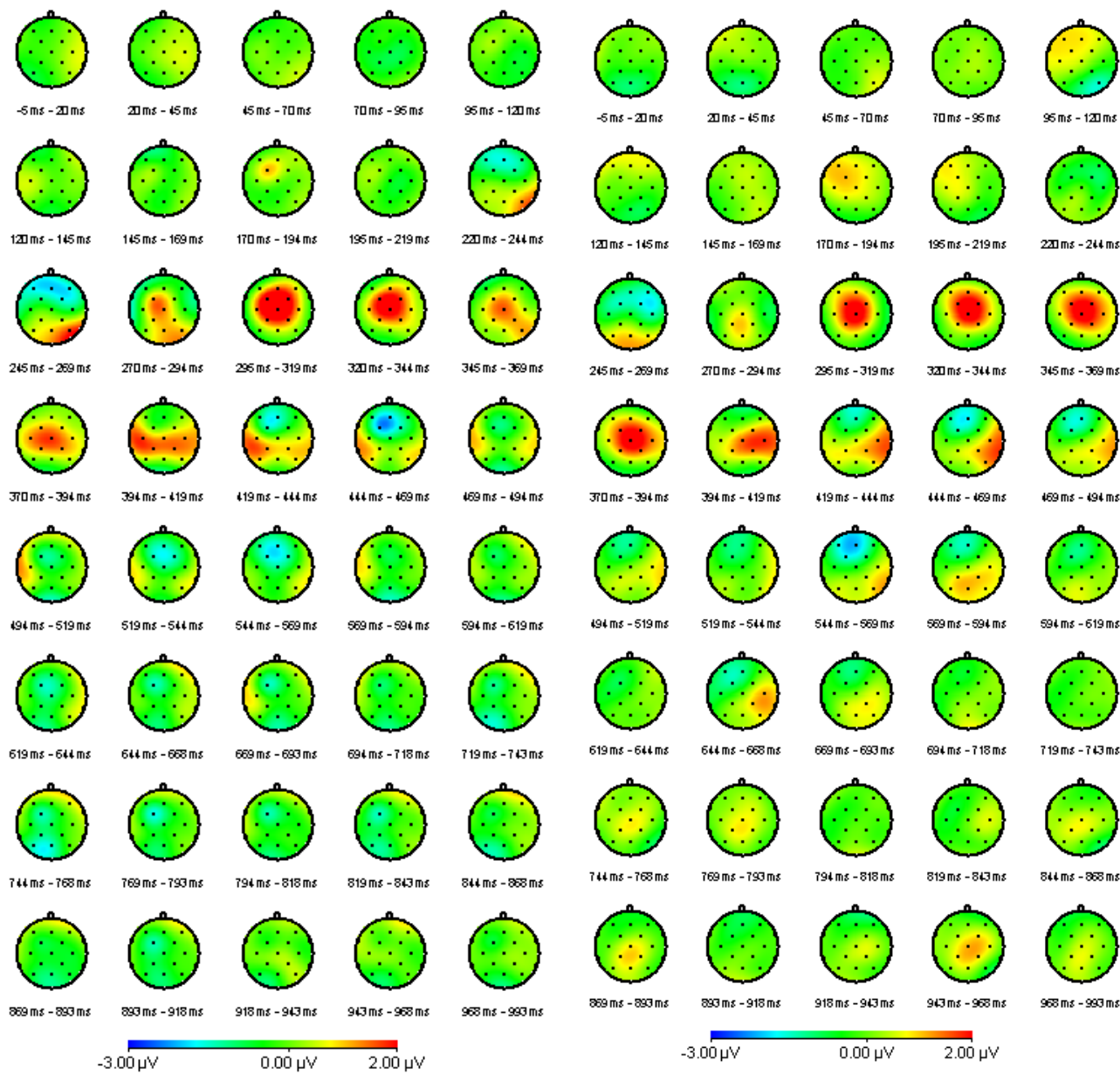

Fig. 3. Spatiotemporal distribution of evoked potentials induced by a 300 ms vibratory stimulation of a right ankle, stimulation frequency 128 Hz

Fig. 4. Spatiotemporal distribution of evoked potentials induced by a 300 ms vibratory stimulation of a left ankle, stimulation frequency 128 Hz

this period the beginning of the activation of a contralateral hemisphere.

A 300 ms vibratory stimulation (with a 128 Hz frequency) of a right wrist induces evoked potentials with a maximum activity observed on electrodes Fz, FC1, FC2, Cz, C3, and CP5. These electrodes lie above the right hand sensory area. A left wrist vibratory stimulation induces an activity that is expressed the most on electrodes Fz, FC1, FC2, Cz, C4, and CP2 which are placed above the left hand sensory area. Figure 5 shows one example of a comparison of evoked potentials induced by the left and the right wrist stimulation.

As it can be seen on Fig. 6 and Fig. 7, in cases of both, the left and the right, wrist stimulation spatiotemporal distribution maps reveal a broad frontocentral area of negative activity with a contralateral distribution that reaches its maximum around 220 ms after the vibration starts. The most pronounced activity is a positive activity in central, frontocentral and centroparietal areas that has a slight contralateral tendency. This activity reaches its maximum around 300-370 ms which is the period after the end of the vibratory stimulation. Nevertheless, regarding its activity emergence before 300 ms, that is, before the moment in which the vibratory stimulus stops, this activity cannot be associated with the vibration termination alone, but is also an indicator of a sensory processing. Also, in the experiment where the stimulus duration was longer than 300 ms, the same activity pattern appears in this specific period.

#### 4 DISCUSSION

In the previous section only the most significant results were presented. During the research experiments with different experimental conditions were performed. Only experimental conditions presented in the previous section are suitable for the future examination.

Given the fact that most of the cortico-spinal fibers cross over to the contralateral side at a level of the medulla oblongata, it was expected that the activity induced by the stimulation of one side of the body would be greater on the contralateral side of the brain. This was true for the wrist stimulation, but the effect was absent during the ankle stimulation. The reason lies in the fact that a foot representation occupies parts of the motor and the somatosensory cortex located deep in the interhemispheric fissure. The motor and the somatosensory cortex associated with an arm is located more laterally, on a surface near the central fissure, corresponding to the cortical area 3b [9]. Therefore activities resulting from the ankle somatosensory cortex become widespread and symmetrical when measured on a scalp. For the same reason, evoked potentials induced by the stimulation of wrists have larger amplitudes than

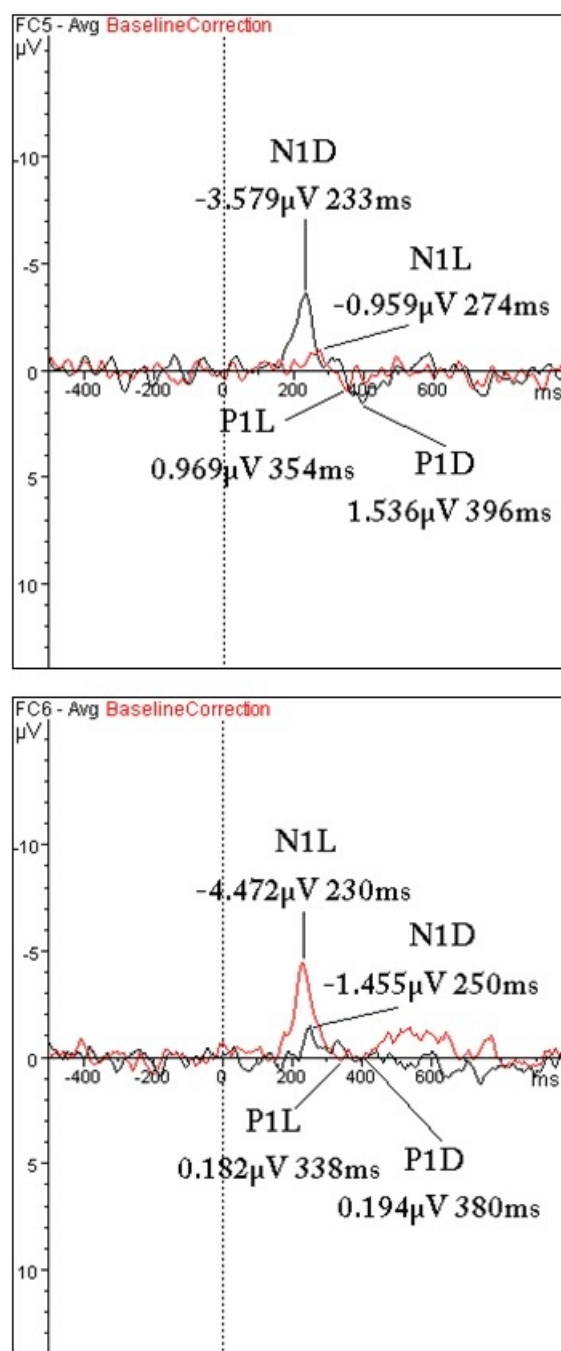

Fig. 5. Comparison of evoked potentials induced by a vibratory stimulation of a right (black) and a left (red) wrist on electrodes FC5 (up) and FC6 (down), stimulation frequency 128 Hz

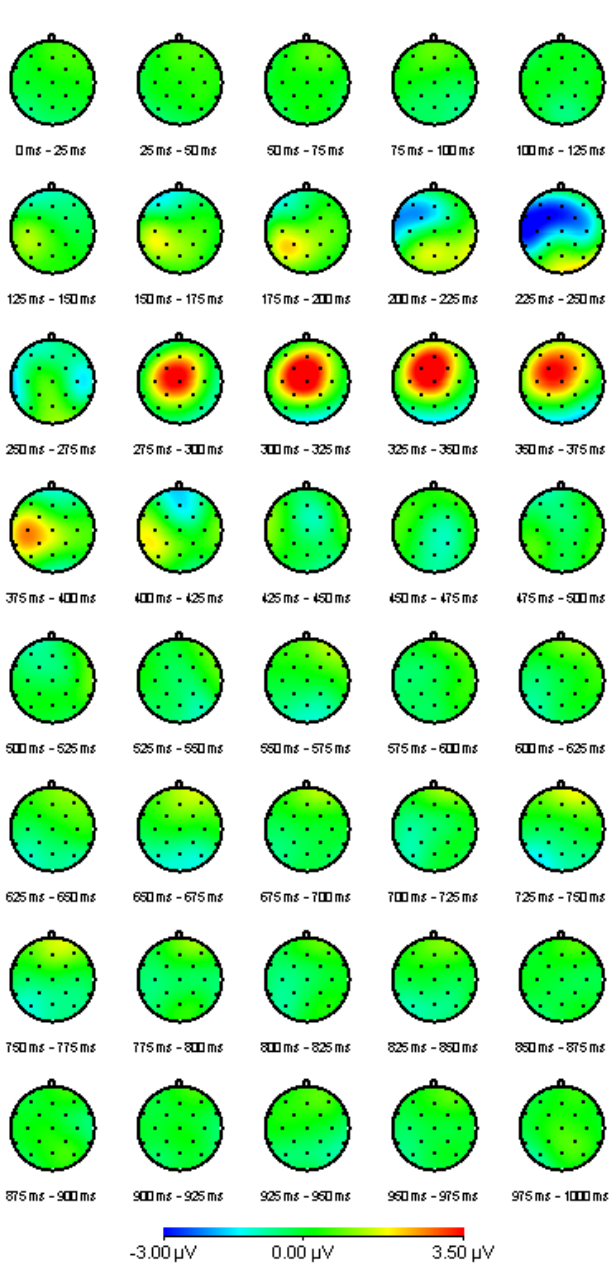

Fig. 6. Spatiotemporal distribution of evoked potentials induced by a 300 ms vibratory stimulation of a right wrist, stimulation frequency 128 Hz

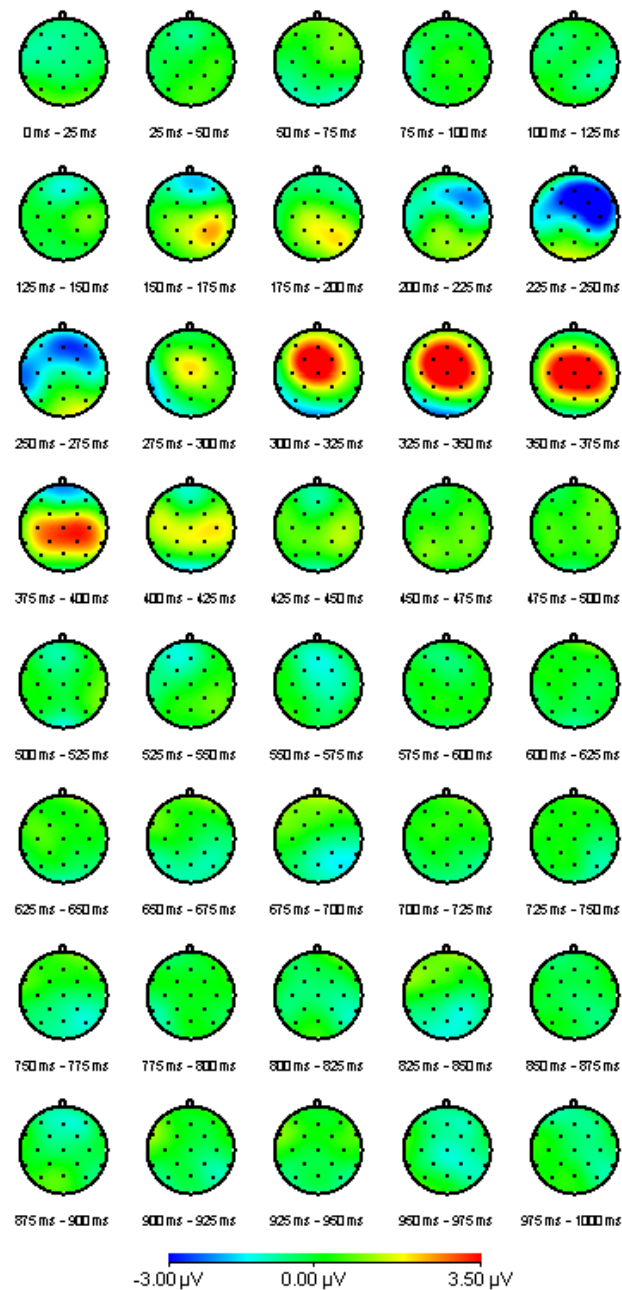

Fig. 7. Spatiotemporal distribution of evoked potentials induced by a 300 ms vibratory stimulation of a left wrist, stimulation frequency 128 Hz



those induced by the stimulation of ankles. Evoked potentials peaks evoked by the ankle stimulation appear later because of the fact that sensory pathways connecting the ankle and its sensory cortical area in the brain are longer than pathways connecting the wrist with specific sensory cortical area.

The stimulation frequency suitable for the future research is 128 Hz. This conclusion is in accordance with the presented theory. Other frequencies also yielded results, but results achieved with the frequency of 128 Hz are most reliable, repeatable and strongly expressed.

During the research different areas of stimulation were investigated. Strongest effects of stimulation were achieved during the stimulation of the wrist and the ankle, so future steps in the research would be to create a stimulator suitable for those parts of the body.

Stimulus durations longer than 300 ms produce almost the same effect as shorter durations. Shortening the stimulus duration can shorten the duration of the experiment or it can enable the increase of a stimuli frequency; in the same time period the number of stimuli is higher which increases the S/N ratio and improves the quality of results. For the future research, only stimulus durations shorter than 300 ms will be considered.

According to results, better results were achieved with the stimulation with the constant frequency. When the change in the frequency is included, then it is questionable which effects are results of a specific parameter of stimulation and which effects are just reactions of human receptors to the change.

The results obtained from the conducted experiments lead us to the conclusion that optimal parameters for future research would be stimulation of wrist and/or ankle with constant stimulation frequency of 128 Hz and with duration shorter than 300 ms.

## 5 CONCLUSION

Presented results confirm the initial assumption that it is possible to detect reliable and repeatable cortical potentials evoked by the vibratory stimulation. Characteristic shapes and spatiotemporal distributions of evoked responses are established. Optimal stimulation parameters are defined as a prelude for the future research.

## REFERENCES

- [1] S. J. Luck, *An Introduction to the Event-Related Potential Technique*. Cambridge, Massachusetts: The MIT Press, 2005.
- [2] A. D. Legatt, "Somatosensory evoked potentials, General Principles", eMedicine, Medscape, 2009  
<http://emedicine.medscape.com/article/1139906-overview>
- [3] E. F. Kelly, M. Trulsson, S. E. Folger, "Periodic Microstimulation of Single Mechanoreceptive Afferents Produces Frequency-Following Responses in Human EEG" *Journal of Neurophysiology*, vol. 77, pp. 137-144, 1997
- [4] E.F. Kelly, D. F. McLaughlin, W. J. Ross Dunseath, S. Folger, F. Jones Jr., H. Kenneth Hudnell, "Frequency-domain measurement of vibrotactile driving responses in first-order afferent populations" *Experimental Brain Research*, vol. 109, pp. 500 – 506, 1996
- [5] M. F. Bear, B. W. Connors, M. A. Paradiso, *Neuroscience: Exploring the Brain*. Philadelphia, USA: Lippincott Williams & Wilkins, 2007
- [6] L. Fattorini, A. Ferraresi, A. Rodio, G. B. Azzena, G. M. Filippi, "Motor performance changes induced by muscle vibration" *European Journal of Applied Physiology*. vol. 98, no. 1, pp. 79-87, May 2006
- [7] T. F. Münte, E. M. Jöbges, B. M. Wieringa, S. Klein, M. Schubert, S. Johannes, R. Dengler, "Human evoked potentials to long duration vibratory stimuli: role of muscle afferents" *Neuroscience Letters*, vol. 216, pp. 163-166, 1996
- [8] A. Z. Snyder, "Steady-state vibration evoked potentials: description of technique and characterization of responses" *Electroencephalography and Clinical Neurophysiology/ Evoked potentials Section*, vol.84, no.3, pp. 257-268, May-June 1992.
- [9] C. Baumgartner, A. Doppelbauer, L. Deecke, D. S. Barth, J. Zeitlhofer, G. Lindinger, W. W. Sitherling, "Neuromagnetic investigation of somatotopy of human hand somatosensory cortex", *Experimental Brain Research*, vol. 87, no. 3, pp. 641-648, 1991



**Magdalena Krbot** received a M.Sc. degree in electrical engineering in 2008 at the University of Zagreb, Faculty of Electrical Engineering and Computing. She is now a PhD student in the field of electrical engineering at the Faculty of Electrical Engineering and Computing, University of Zagreb. Since 2009 she has worked as a research assistant at the University of Zagreb. Her scientific interests lie in the field of the biomedical engineering and signal analysis. She is a member of the Croatian Medical and Biomedical Engineer-

ing Society.



**Ana Branka Šefer** is a research assistant at the University of Zagreb. She received a M.Sc. degree in electrical engineering in 2008 at the University of Zagreb, Faculty of Electrical Engineering and is now a doctoral student at the same faculty. Her scientific interest is in biomedical engineering and biomedical signal analysis. She is a member of Croatian Medical and Biological Engineering Society.



**Mario Cifrek** was born in Varaždin, Croatia in 1964. He received the Dipl.-Eng., M.Sc., and Ph.D. degrees in electrical engineering from the Faculty of Electrical Engineering and Computing, University of Zagreb, Croatia in 1987, 1992, and 1997, respectively. He is currently Professor of electronic measurements, instrumentation, and biomedical engineering with the Department of Electronic Systems and Information Processing, Faculty of Electrical Engineering and Computing, University of Zagreb. His research inter-

ests are focused on design of biomedical instrumentation and signal analysis for research and clinical applications. He is a member of IEEE (Institute of Electrical and Electronics Engineers), EMBS (Engineering in Medicine and Biology Society), IFMBE (International Federation for Medical and Biological Engineering), IFAC (International Federation for Automatic Control) - TC Human-Machine Systems, CROMBES (Croatian Medical and Biological Engineering Society), KoREMA (Croatian Society for Communications, Computing, Electronics, Measurement and Control), and HMD (Croatian Metrology Society). Since 2005 he is a collaborating member of the Croatian Academy of Engineering.



**Zoran Mitrović MD** received in 1974 from Zagreb University Medical School. MS degree in Neurobasis of behavior from Yale University Graduate School in 1977. Since 1982 neurologist at the National Center for Neuromuscular Disorders and Dept. of Neurology, Clinical Hospital Center Zagreb. In 1985 visiting researcher at Neurology Dept, Univ. of Oxford, and in 1994 at Neurophysiology Dept., Univ. College London. Involved in development and the application of clinical neurophysiological techniques,

using electromyography, nerve conduction and monosynaptic reflexes, particularly in the diagnostics of hereditary neurological conditions.



**Igor Krois** received the Ph.D. degree in electronics from the University of Zagreb, Zagreb, in 2001, where he focused on fast recording of intraoperative evoked potentials. He is currently with the Faculty of electrical engineering and computing, University of Zagreb, Zagreb. His current research includes a fail safe electric stimulators

for recording of intraoperative evoked potentials and stimulation systems for recording of vibration evoked potentials.



**Velimir Išgum** received B.Sc. degree in 1971, M.Sc. degree in 1978 and Ph.D. degree in 1983 at the Faculty of Electrical Engineering, University of Zagreb. Since 1974 he has been employed at the Department of Neurology, University Hospital Rebro, Zagreb where he currently holds position as a head of the Laboratory for cognitive and experimental neurophysiology. He currently teaches at postgraduate study at the Faculty of

Electrical Engineering and Computing, the School of Medicine, and the interdisciplinary scientific doctoral study Language and Cognitive Neuroscience, all at the University of Zagreb. He conducted several national and international scientific projects. He is a member of CROMBES (past president of Clinical engineering section), Croatian Society for Medical Informatics, International Society of Intraoperative Neurophysiology, and Croatian Society for EEG and Clinical Neurophysiology.

#### AUTHORS' ADDRESSES

**Magdalena Krbot, Ms. E.E.**

**Ana Branka Šefer, Ms. E.E.**

**University of Zagreb,**

**Trg Maršala Tita 14, HR-10000 Zagreb, Croatia**

**email: mkrbot@gmail.com, anabranka@gmail.com**

**Prof. Mario Cifrek, Ph.D.**

**Department of Electronic Systems and Information Processing,**

**Faculty of Electrical Engineering and Computing,**

**Unska 3, HR-10000 Zagreb, Croatia**

**email: mario.cifrek@fer.hr**

**Zoran Mitrović, MD, M.Sc.**

**Department of Neurology,**

**University Hospital Zagreb,**

**Kišpatićeva 12, HR-10000 Zagreb, Croatia**

**email: zoran.mitrovic@zg.t-com.hr**

**Asst. Prof. Igor Krois, Ph.D.**

**Department of electronics, microelectronics, computer and intelligent systems,**

**Faculty of Electrical Engineering and Computing,**

**Unska 3, HR-10000 Zagreb, Croatia**

**email: igor.krois@fer.hr**

**Asst. Prof. Velimir Išgum, Ph.D.**

**Department of Neurology,**

**University Hospital Zagreb,**

**Kišpatićeva 12, HR-10000 Zagreb, Croatia**

**email: velimir.isgum@kbc-zagreb.hr**

Received: 2010-09-13

Accepted: 2011-02-16