

# Comparison of Electrical Equivalent Circuits of Human Tooth used for Measuring the Root Canal Length

UDK 621.317.39:612.31  
IFAC 5.9.2

Original scientific paper

An accurate determination of the root canal length, which is the most critical procedure in the endodontic treatment of a tooth, is commonly performed nowadays by electronic apex locators which are based on electrical impedance measurements.

In this paper tooth impedances were measured *in vitro* on extracted tooth in alginate material using HP 4284A LCR meter and a specially designed stalk with a micrometer for precise file positioning. In order to develop a more accurate measurement procedure human tooth was modeled by electrical equivalent circuit.

Four new equivalent circuits comprising of resistors, capacitors and constant-phase elements were proposed in this paper and compared with four previously suggested circuits. Elements of equivalent circuits were determined by complex nonlinear least squares fitting using LEVM software. Different quality factors were defined to describe the fit quality of a certain equivalent circuit at each file position. The overall fitting efficiency in the region of file positions of interest was calculated as well.

A detailed discussion was given on equivalent circuit parameters that can be used to measure the root canal length. Upon these results the most appropriate equivalent circuit was selected and a new measurement procedure was proposed.

**Key words:** Electronic apex locator, Complex nonlinear least squares fitting, Electrical equivalent circuit of tooth, Root canal length measurement

**Usporedba električkih nadomjesnih shema ljudskog zuba korištenih za mjerenje duljine korijenskog kanala.** Točno određivanje duljine korijenskog kanala zuba, što je najkritičniji postupak u endodontskom tretmanu, se uobičajeno danas provodi elektroničkim detektorima apeksa koji se temelje na mjerenju električne impedancije.

U ovoj studiji su impedancije zuba izmjerene *in vitro* na izvađenom zubu uronjenom u alginat. Korišten je HP 4284A LCR metar i posebno izrađeni stalak s mikrometrom za precizno pozicioniranje endodontskog instrumenta u kanalu. U svrhu razvoja točnije mjerne metode ljudski je zub modeliran električkom nadomjesnom shemom.

Četiri nove nadomjesne sheme sastavljene od otpora, kapaciteta i elemenata s konstantnom fazom su predložene u ovom radu i uspoređene s četiri ranije predložene nadomjesne sheme. Elementi nadomjesnih shema su izračunati metodom kompleksnih nelinearnih najmanjih kvadrata korištenjem programa LEVM. Definirano je više faktora kvalitete kako bi se usporedilo svojstvo nadomjesnih shema da modeliraju izmjerenu impedanciju na pojedinim položajima endodontskog instrumenta u kanalu. Izračunati su i faktori kojima se uspoređuje sveukupna efikasnost nadomjesne sheme.

Detaljno su objašnjeni parametri nadomjesnih shema koji se mogu koristiti za mjerenje duljine korijenskog kanala. Temeljem dobivenih rezultata odabrana je najpogodnija nadomjesna shema te je predložen novi mjerni postupak.

**Ključne riječi:** elektronički detektor apeksa, metoda kompleksnih nelinearnih najmanjih kvadrata, električka nadomjesna shema zuba, mjerenje duljine korijenskog kanala zuba

## 1 INTRODUCTION

When the pulp is infected, all pulp tissue, microorganisms and necrotic material should be removed from the tooth, the canal should be cleaned and filled with inert material. During that procedure a minimal irritation of surrounding tissue is required.

The root canal length is measured during the endodontic treatment to determine the working length i.e. how deep should the canal be instrumented. The pulp extraction is performed by using a Kerr file of required size. The root canal should be instrumented to or short of the apical constriction, which is commonly positioned 0.5 to 0.8 mm

from the apical foramen, depending on the age and type of the tooth [1], Fig. 1. The success of whole endodontic treatment depends on the accuracy of working length determination.

Root canal length is commonly measured by electronic apex locator or by radiograph [2,3]. However, on a radiographic projection the root canal curvature and overlapping can cause difficulties during measurement of the working length. Therefore electronic apex locators are preferred to be used for measuring the working length [4].

First-generation apex locators (also known as resistance apex locators) use direct current and measure DC resistance between the Kerr file inside the root canal and the oral mucosa [5,6]. Due to numerous disadvantages of resistance apex locators [4,7] present apex locators use alternating current and measure impedance at one or more frequencies [6]. The position of the file can be determined based on the module of impedance, difference between impedances, or their ratio, depending on the type of apex locator [6]. Various tooth morphology and the presence of irrigants used during the endodontic treatment influence the impedance of different tooth segments and cause inaccuracy of apex locators [2,4,8]. Influence of those physical parameters on the accuracy of apex locators can be minimized by measuring the impedance at more than one frequency [9,10].

To develop improved measurement method, tooth is modeled by electrical equivalent circuit whose elements are defined by analyzing impedance in frequency domain (so called impedance spectroscopy) [11]. Values of those elements change during the movement of the file into the root canal. Therefore it is possible to distinguish impedance components which are constant and represent impedance of the tooth from those which are changing and depend on the file position. It could be possible to define the file position in the root canal more accurately because the influence of tooth morphology on measurement result is eliminated.

In our previous work possibilities of using two-element and three-element equivalent circuits that include linear frequency-independent components were examined [8,10,12-15]. Some authors have also proposed a few simpler [16] and more complex [17] equivalent circuits.

The aim of this study is to find the most appropriate equivalent circuit that represents impedance behavior of a human tooth in a wide frequency range (100 Hz to 1 MHz). Beside that, chosen equivalent circuit has to represent real physiological condition in the tooth, so electrical elements which depend on the file position could be isolated and thus the accuracy of the file position inside the root canal improved.

The structure of the paper is as follows. Impedance measurement on extracted tooth is explained in Section

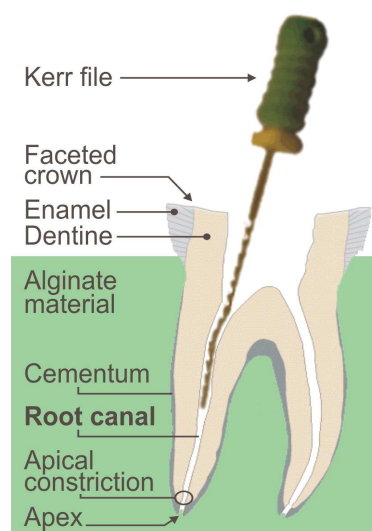

Fig. 1. Tooth anatomy

2. In Section 3 electrical equivalent circuits are defined. Curve fitting procedure is explained in Section 4. In Section 5 fit quality factors are calculated. Estimated values of equivalent circuit parameters are given and interpreted in Section 6. Based on these results, a new measurement procedure is proposed in Section 7. Discussion and Conclusion follow in sections 8 and 9.

## 2 TOOTH FIXATION AND IMPEDANCE MEASUREMENT

A single rooted incisor tooth was used in this study. Between the extraction of the tooth and impedance measurement the tooth was held in saline solution. A mounting stalk has been built for precise file positioning (Fig. 2) inside the root canal. Stalk construction with an installed micrometer ensures positioning stability and repeatability. The tooth has been fixed on the stationary part of the stalk and the file scrolled down the canal until the file tip was detected with a microscope at the apical foramen. A Kerr file K-15 was used since it fitted best in the examined canal. After that, the tooth has been immersed in freshly mixed alginate prior to the hardening of the material. The alginate material is widely used as a physical model for *in vitro* measurements [2,4,12,15] since it has adequate physical and electrical properties. We have used Fast Set alginate dental impression material by GC Europe n.v. (Leuven, Belgium) prepared according to manufacturer's instructions using tap water.

After hardening of the alginate material the file was scrolled out of the canal, the canal was rinsed with normal saline solution (0.9%) and blown out with air.

The Kerr file was used as the active electrode for impedance measurement. For the neutral electrode a stain-

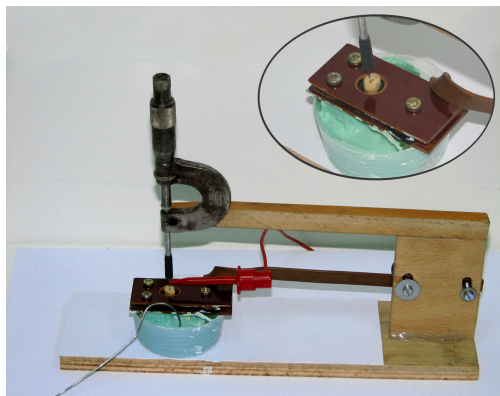

Fig. 2. A mounting stalk for precise file positioning

less steel with a large area was immersed in alginate material. Impedance of the neutral electrode is considered negligible in this paper due to a large contact area. Real and imaginary parts of impedance were measured using the precise LCR meter HP 4284A by Hewlett Packard. The LCR meter was controlled by computer using HP VEE software. By using the installed micrometer, the file was precisely positioned from  $-3.25$  mm to  $+0.75$  mm relative to the apical foramen in increments of  $0.25$  mm. The file was scrolled unidirectionally down the canal during the experiment to avoid mechanical hysteresis. Impedances were measured at 13 logarithmically distributed frequencies in the range from  $100$  Hz to  $1$  MHz for each position of the file tip.

Negative values of the file tip displacement indicate that the file tip is located inside the root canal, and positive that the file has passed through the canal.

After impedance measurement of tooth in the alginate, impedance measurements were repeated with the tooth immersed in the  $0.9\%$  saline solution at  $-0.5$  mm,  $0$  and  $+0.5$  mm for quick comparison and reference purposes. After all measurements were completed, the tooth was faceted to measure the apical foramen displacement from the apical constriction represented as a zero in this paper.

### 3 EVALUATED ELECTRICAL EQUIVALENT CIRCUITS

Each electrical equivalent circuit tends to represent the frequency behavior of the measured impedance  $Z = R + jX$  at a certain position of the file tip using a finite number of parameters. Complex tooth anatomy, different electrical properties of different tissues in addition to the electrode-solution interface complicates the task. A number of different equivalent circuits exist and it is important to evaluate them to determine which one is suitable for particular use.

Prior to this study we have used equivalent circuits with two or three linear elements (resistors and capaci-

tors) to model the tooth [8,10,12-15]. They could represent impedance behavior in a narrow frequency range, but their elements had to be frequency dependent in order to describe impedance in wider frequency range.

Since the double-layer which occurs at the boundary of a metal electrode can not be properly modeled by a simple combination of passive linear components (like resistors and capacitors), in this paper we have used a *constant phase element* (CPE) to approximate electrode-solution interface phenomena. The impedance of a constant phase element is defined with two parameters,  $Q$  and  $n$  as

$$Z_{CPE}(\omega) = \frac{1}{Q(j\omega)^n}. \quad (1)$$

With  $n$  close to zero, CPE behaves like a resistor (with value of  $Q^{-1} [\Omega]$ ) and  $Z_{CPE}$  is independent of frequency with a zero phase. On the other hand, when  $n$  approaches unity, CPE behaves like a pure capacitor (with capacitance equal to  $Q [F]$ ).  $Z_{CPE}$  decreases with frequency by  $20$  dB per decade with the phase of  $-90^\circ$ . In reality the value of  $n$  is between  $0$  and  $1$ , and the CPE behaves like something between resistor and capacitor with constant phase between  $0$  and  $-90^\circ$  defined with  $n$ .

Eight equivalent circuits have been compared in this study. Circuits A and B were proposed in [16] to represent the impedance behavior of electrode-solution contact (without the tooth) and impedance behavior when the file is placed inside the root canal respectively, Fig. 3.

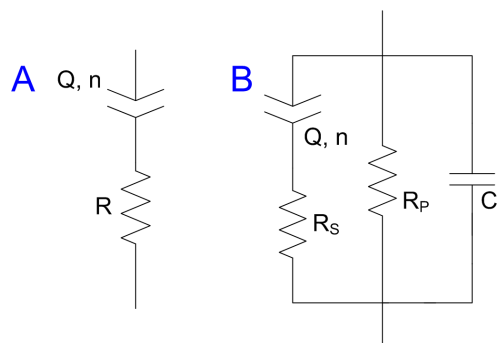

Fig. 3. Electrical equivalent circuits A and B

Circuits C, D and E are proposed in this paper for further elaboration, Fig. 4. Circuit C offers simplistic improvement over B without addition of any extra elements, while D includes one extra capacitor for representation of electrode-solution interface. Circuit E involves one additional CPE instead of a parallel of a resistor and a capacitor to describe the behavior of dentin, as suggested but not demonstrated in [16].

Circuits F and G (Fig. 5) were proposed in [17] to represent the impedance behavior of mimic human tooth made

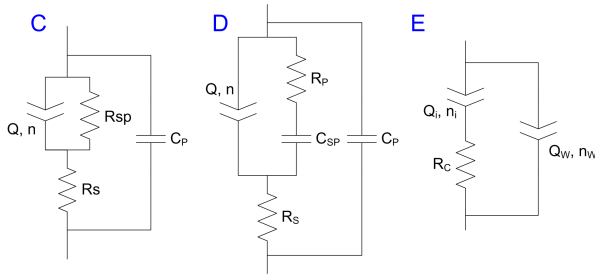

Fig. 4. Electrical equivalent circuits C, D and E

as acrylic tubule leaned on agar gel. Circuit F was intended to represent impedance inside the root canal (negative displacements) and circuit G over the apex (positive displacements).

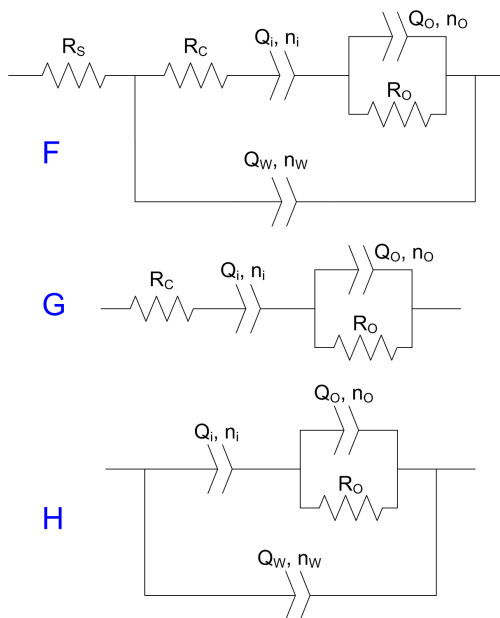

Fig. 5. Electrical equivalent circuits F, G and H

Circuit H (Fig. 5) is also proposed in this paper as an empirical simplification to be used instead of circuit F.

#### 4 PARAMETER ESTIMATION PROCEDURE

Parameters for each equivalent circuit were estimated by curve fitting using LEVM Complex Nonlinear Least Squares (CNLS) software [11]. The aim of least squares method is to find a set of equivalent circuit parameters  $P$  which will minimize the sum:

$$S(P) = \sum_{j=1}^M w_j [Y_j - YC_j(P)]^2, \quad (2)$$

where  $Y_j$  is the  $j^{\text{th}}$  data point,  $YC_j(P)$  is the corresponding value of the calculated model function using the set of

parameters  $P$ ,  $w_j$  is the associated weight factor and  $M$  is the total number of data points. In the case of complex data fitting procedure, there are two values describing each data point and the sum is adjusted to value both real and imaginary parts separately:

$$S(P) = \sum_{j=1}^M w_{Re,j} Re^2 \{Y_j - YC_j(P)\} + \sum_{j=1}^M w_{Im,j} Im^2 \{Y_j - YC_j(P)\}. \quad (3)$$

Weighting factors  $w_{Re,j}$  and  $w_{Im,j}$  can be calculated from the measured and estimated data points in different ways and their choice is crucial for the achievement of a good fit. Because we dispose of a wide range of values for both real and imaginary parts of measured impedances and are using a number of different model functions we have chosen data weighting type and defined weighting factors as:

$$w_{Re,j} = 1/Re^2 \{Y_j\}, \quad (4)$$

$$w_{Im,j} = 1/Im^2 \{Y_j\}. \quad (5)$$

In other words, we have fitted impedances by minimizing standard deviation of the relative fit residuals for both resistance and reactance parts using the same weights in the entire frequency range.

After the initial fit was successfully obtained, weighting factors were optimized to balance the real weights against the imaginary to enhance the influence of more accurate part of measured data. In that way the full data set is used to optimize the determination of the parameter estimates, see weighting choices and CNLS optimization in LEVM Manual [11].

Each examined electrical equivalent circuit produces nonlinear model fitting function. Contrary to ordinary least squares method, if the function is nonlinear in any of its parameters, fitting requires initial parameter guesses and iteration. In nonlinear least squares method non-convergence is a common phenomenon and aggravates with circuit complexity, especially if parameters occur in exponents as in the case of CPE elements. The solution is rarely unique while multiple minima exist in the sum of squares and nonlinear estimates are generally biased unless weighting factors are properly set.

By careful selection of initial guesses and by building up complex equivalent circuits starting with the most significant components only, the best solution of estimated parameters for each equivalent circuit at a single file tip position were found.

## 5 EQUIVALENT CIRCUIT FIT QUALITY EVALUATION

### 5.1 Measures used to describe the quality of fit

We define the fit quality factor for each equivalent circuit as a standard deviation of the relative fit residuals (parameter which is minimized during the fitting process) of a best achieved fit,  $SIGMAF$  or just  $SF$ ,

$$SF^2 = \frac{1}{N} \sum_f \left[ \left( \frac{R_{\text{model}} - R_{\text{tooth}}}{R_{\text{tooth}}} \right)^2 + \left( \frac{X_{\text{model}} - X_{\text{tooth}}}{X_{\text{tooth}}} \right)^2 \right], \quad (6)$$

where  $R_{\text{model}}$  and  $X_{\text{model}}$  represent real and imaginary parts of calculated impedances, while  $R_{\text{tooth}}$  and  $X_{\text{tooth}}$  represent measured impedances.

The goal of equivalent circuit is to represent measured impedance behavior with minimal complexity. To include circuit complexity we have defined normalized fit quality factor as the  $SF$  value multiplied with the number of free parameters  $N$  in the individual equivalent circuit. Number of free parameters is used as a measure of equivalent circuit complexity although one CPE is generally harder to estimate than values of a resistor and a capacitor.

To compare overall fitting efficiency of an equivalent circuit over the entire file path, we have defined a measure  $WASF$  as a weighted average of  $SF$ .  $WASF$  values are expressed as percentages while they represent average fit error for individual equivalent circuit.

Normalized  $WASF$  values are used to include circuit complexity again. Normalization is also performed by multiplying  $WASF$  values with the number of free parameters in the individual circuit. The percentage here indicates the contribution of one free parameter of equivalent circuit on a total fit error as if all parameters would contribute equally and linearly to reduce the total error<sup>1</sup>.

By using different weighting windows (i.e. coefficients for each position) we can observe circuit efficiency in desired range of file tip positions. We have compared  $WASF$  results by using four different weighting windows defined on Fig. 6.

The first window WA weights overall fitting efficiency of equivalent circuit inside the root canal (up to -0.75 mm). Window WB weights the circuit inside the region of clinical interest (-1 to +0.5 mm). Window WC weights it at a

<sup>1</sup>For example if normalized  $WASF$  amounts 66 % for each one of three free parameters in equivalent circuit, then the total expected error when using two parameters is  $66 / 2 = 33$  % and when using all three parameters is  $66 / 3 = 22$  %, which is exactly the value of  $WASF$  without the normalization.

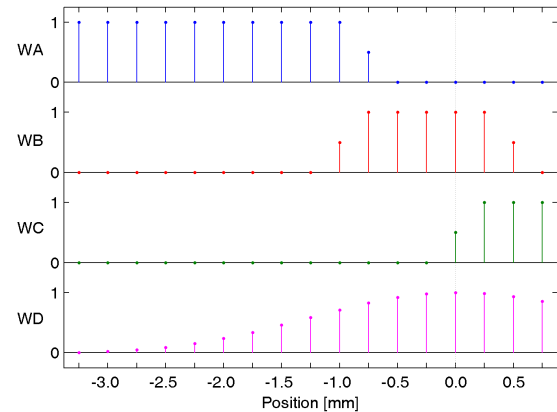

Fig. 6. Weighting windows used for the calculation of the overall equivalent circuit fitting efficiency

few inmost positions of a file (over the apex only). Window WD weights the overall circuit fitting efficiency by using all available measurements and weights evenly portions below and above -0.25 mm, which is assumed to be at the center of the clinically interesting region.

### 5.2 Fitting performances of different equivalent circuits

Figure 7 shows  $SF$  as a function of file tip position for all analyzed equivalent circuits. It could be seen that equivalent circuit A can not describe impedance behavior in the entire frequency range especially with the file tip located inside the root canal. Circuit B can be used for every file tip position, but it has shortcomings.

Circuits C, D and E were proposed in this paper. Circuit C showed improved behavior over B at -0.5 mm only, while the circuit D turned out to be better at each file po-

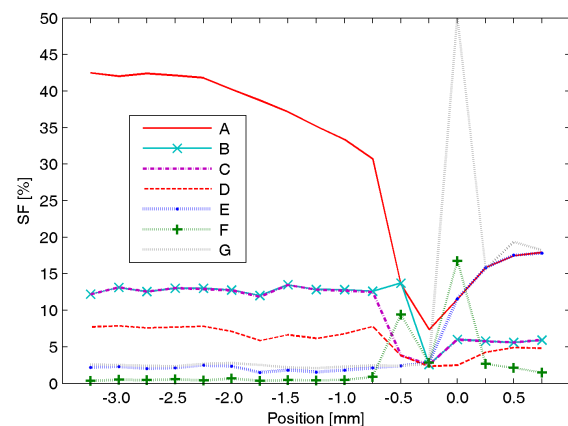

Fig. 7.  $SF$  as a function of the file tip position for equivalent circuits A to G

sition. Furthermore, circuit E showed significant improvement inside the root canal, but in the region over the apex it behaves similar to the circuit A.

Circuit F has shown the best fitting performances at each file tip position except in the most essential region around the apex. It is important to notice that a good fit was expected due to a relative complex structure of circuit F. Around the apex both circuits F and G (proposed in [17]) exhibit a considerable error.

Fit quality factor for circuit H has not been shown on Fig. 7 due to a significant overlap with curve F.

Figure 8 shows normalized  $SF$  as a function of the file tip position for all equivalent circuits. It could be seen that equivalent circuit H proposed in this paper showed the best fitting performances in normalized manner inside the root canal. At positions from -3.25 to -0.75 mm the improvement is achieved because it contains two elements less than circuit F, and at the position of -0.5 mm it has obtained a significantly better fit.

Table 1 shows  $WASF$  values obtained for all equivalent circuits in the region defined with weighting windows WA to WD. Table 2 shows normalized  $WASF$  values also obtained for all equivalent circuits and for windows WA to WD.

It could be seen that inside the root canal (WA) both equivalent circuits F and H result with practically the same error (0.48 %). Because the circuit H uses fewer elements, utilization of each free parameter is better by factor 9/7. On the other hand, circuit H can not be used near to and over the apex (WB to WD). In the region of clinical interest (WB), circuit D yields the best performance in both total and normalized manner. Following the circuit D is the circuit F in total manner, but in normalized manner there are circuits C, E, B and only then F. Over the apex (WC) circuit F showed best fitting performances in total manner, but in normalized circuits D, C and B are better than F due to its simplicity. Similar behavior is observed when accounting the entire file path (WD) - circuit F is the best in total manner, but in normalized the circuit D turned out better.

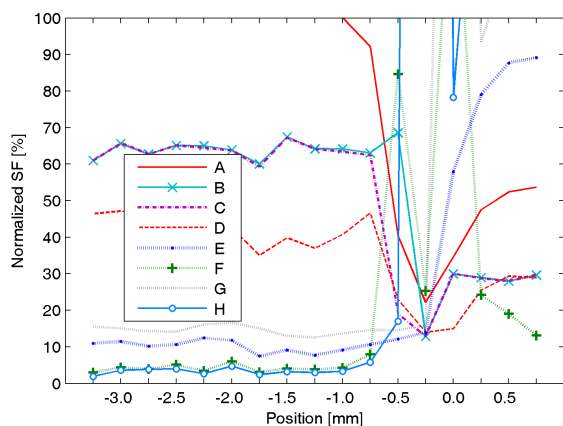

Fig. 8. Normalized  $SF$  as a function of the file tip position for equivalent circuits A to H

Table 1. An overall error for equivalent circuits A-H

Equivalent circuit	$WASF$ values			
	window WA, %	window WB, %	window WC, %	window WD, %
A	39.14	17.40	16.27	21.99
B	12.78	8.32	5.80	8.92
C	12.73	6.63	5.80	7.89
D	7.15	4.42	4.35	4.94
E	2.02	7.40	16.28	7.68
F	0.48	5.64	4.18	3.93
G	2.43	13.98	22.34	12.23
H	0.48	35.60	33.65	29.47

Shaded values indicate minimal  $WASF$  value for each window.

Table 2. An overall error for equivalent circuits A-H normalized with the number of free parameters

Equivalent circuit	$N$	Normalized $WASF$ values			
		window WA, %	window WB, %	window WC, %	window WD, %
A	3	117.41	52.19	48.82	65.98
B	5	63.88	41.59	29.02	44.62
C	5	63.64	33.16	28.99	39.47
D	6	42.91	26.51	26.07	29.64
E	5	10.12	37.00	81.39	38.40
F	9	4.29	50.74	37.63	35.37
G	6	14.59	83.90	134.01	73.39
H	7	3.37	249.21	235.52	206.27

Shaded values indicate minimal normalized  $WASF$  value for each window.

From the preceding results and discussion it is important to notice that good fitting performances of an equivalent circuit are desirable, but they do not necessarily imply accurate determination of the apex when using this circuit.

From the preceding results and discussion it is important to notice that good fitting performances of an equivalent circuit are desirable, but they do not necessarily imply accurate determination of the apex when using this circuit.

## 6 PARAMETERS THAT CAN BE USED TO MEASURE THE FILE TIP POSITION

In order to make conclusions about the file tip position inside the root canal, both circuit simplicity and fit quality are equally important. The goal is to find a parameter that can be easily and undoubtedly estimated out of measured impedance values. That parameter should ideally depend only on the file tip position. If the obtained fit is poor,

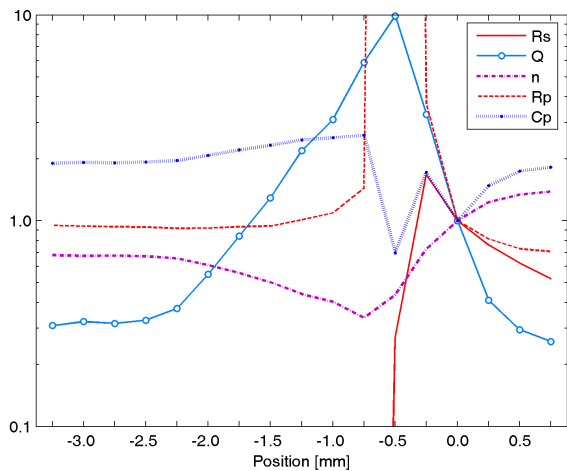

Fig. 9. Normalized equivalent circuit parameters depending on the file tip position - circuit B

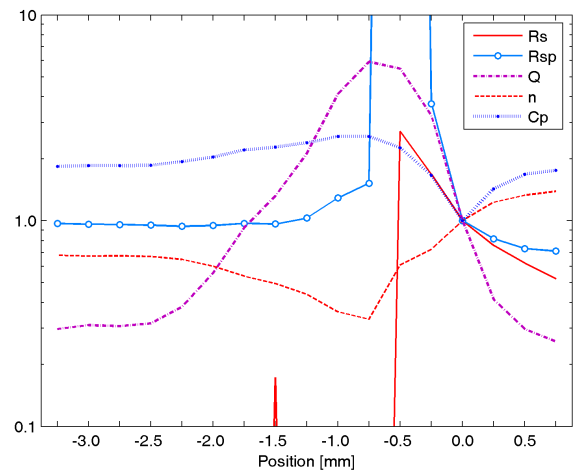

Fig. 10. Normalized equivalent circuit parameters depending on the file tip position - circuit C

used model probably does not contain enough information about electrical behavior inside the root canal and accordingly lacks the ability to distinguish parameters that dependent on the file tip position. If the equivalent circuit is too complicated, fit parameters are no longer uniquely defined (i.e. they are highly intercorrelated).

Figures 9 to 13 show the dependence of certain elements of individual equivalent circuits on the file tip position. Since the parameter values differ significantly from each other, they are normalized in order to display them in the same figure. Normalization is performed by dividing each value with the value of the same parameter obtained at the apex. Exception from this normalization procedure are parameters  $Q_w$  in the circuit E and  $R_s, R_c, Q_o, Q_w$  in the circuit F because they tend to zero at the position of the apex. These parameters are normalized by dividing their values with the first reasonable value closest to the apex.

Circuits A and G have shown bad fitting performances and therefore they are omitted from this discussion.

Knowing the tooth anatomy, we can conclude that in the circuit B parameter  $Q$  raises due to an increased double-layer area when the file is inserted deeper in the root canal. Therefore it *can not be used* for the estimation of the file tip displacement from the apex. Note that CPE (described with  $Q, n$ ) behaves more like a resistor when the file approaches the apex ( $n$  decreases), while  $R_s$  remains at very low value up to the -0.50 mm. After this point CPE changes its behavior and behaves more like a capacitor as the file is going deeper. This indicates that CPE represents different electrical parts of the tooth when the file tip is inside the canal and when it is near the apex.

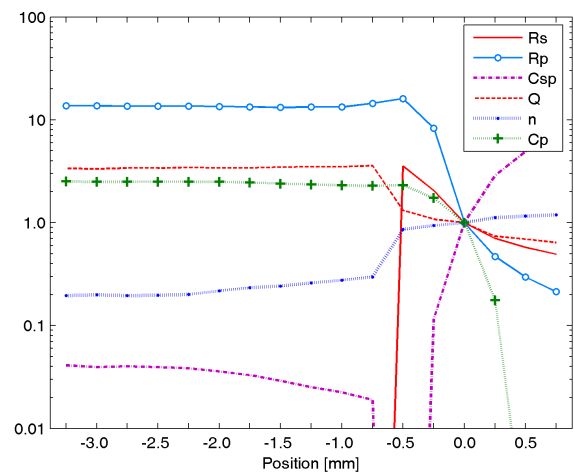

Fig. 11. Normalized equivalent circuit parameters depending on the file tip position - circuit D

When the file tip is located near the apex, CPE represents file-to-electrolyte contact, and when the file tip is located inside the root canal CPE tends to represent dentin behavior as well. That leads to a rapid decrease of parameter  $R_s$  which is expected to represent the resistance of the root canal from the file tip to the apex.

Similar discussion applies with the circuit C, except that parameters behave more smoothly just before the apex.

In the circuit D the electrode-solution interface is described with one additional parameter,  $C_{sp}$ . When the file is moving deeper inside the root canal and all the way to the -0.5 mm, the value of  $C_{sp}$  decreases simultaneously with the increase of  $n$  (CPE behaves more capacitive), while the  $R_s$  is negligible again. This means that inside the root canal CPE,  $R_p$  and  $C_{sp}$  are all trying to represent dentin behavior as well, therefore no isolated information on file

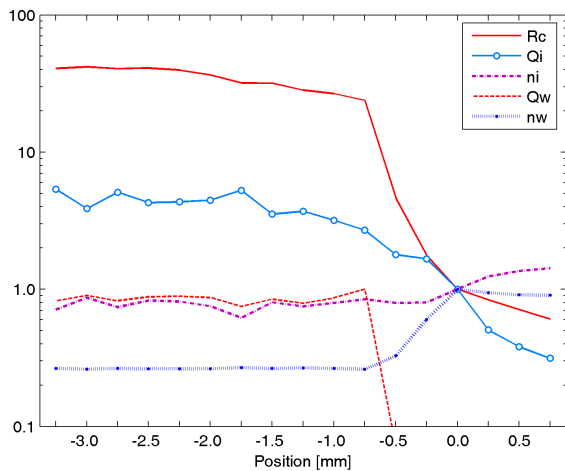

Fig. 12. Normalized equivalent circuit parameters depending on the file tip position - circuit E

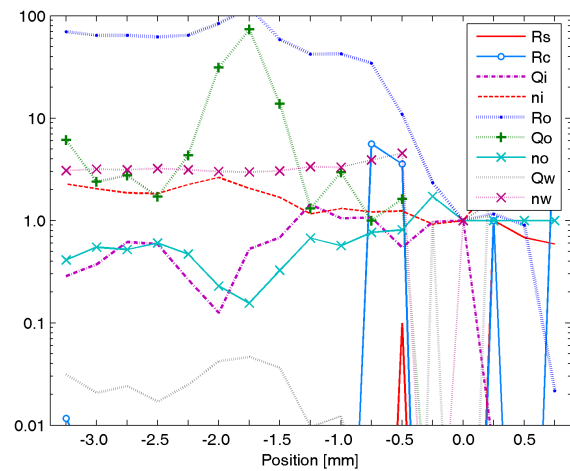

Fig. 13. Normalized equivalent circuit parameters depending on the file tip position - circuit F

tip position exist in these elements. Therefore circuit D also *can not be used* for the estimation of the file tip position inside the root canal. After the position of -0.5 mm is reached,  $R_s$  does not tend to zero anymore. The CPE can now represent the file-to-solution interface and the  $R_s$  resistance of the remaining portion of the root canal.

Circuit E appears to be *the best choice* for the estimation of the file position inside the root canal. Impedance behavior of dentin is represented sufficiently by parameters  $Q_w$  and  $n_w$ . Therefore  $Q_i$  and  $n_i$  are free to describe the file-to-solution interface behavior. That leaves enough room to reliably estimate resistance inside the root canal  $R_c$ . Relatively poor *WASF* values of circuit E especially over the apex (Table 1) indicate that considerable amount of unmodeled circuit parameters remain. However, circuit simplicity allows unambiguous determination of important elements. After the position of -0.5 mm is reached the influence of dentin on the total impedance becomes secondary. Therefore parameters  $Q_w$  and  $n_w$  that describe dentin behavior lose their consistency, but without interfering with the estimation of the other parameters.

Although the circuit F has shown good fitting performances, the complexity of the model prevents an unambiguous assessment of parameters. Figure 13 shows that the parameters are not monotonic and thus *can not be used* to estimate the position of the file inside the root canal. Small changes in initial guess along with measurement uncertainties significantly change all parameter estimates, i.e. convergence problem is severe. Using two equivalent circuits depending on current file position as proposed in [17] also complicates the estimation of the file position inside the root canal.

Circuit H is simpler than F (it lacks two elements), however a similar behavior applies on its estimated parameters.

Therefore further analysis was omitted from this discussion.

## 7 PROPOSED MEASUREMENT PROCEDURE

In the Section 6 we have found that circuit E should be used as a tooth model for estimation of the file tip position inside the root canal. Parameters  $Q_w$  and  $n_w$  of equivalent circuit E represent the dentin and do not depend on file position inside the root canal (Fig. 12). We recommend calculating these parameters at any location inside the root canal (from -3.25 to -0.75 mm) and keeping them unchanged during the rest of endodontic procedure. Therefore equivalent circuit E becomes significantly simpler. Only three parameters remain to be estimated, which can be done easily and unambiguously.

Figure 14 shows estimated  $R_c$ ,  $Q_i$  and  $n_i$  for simplified equivalent circuit E using fixed values for  $Q_w$  and  $n_w$  (once obtained at the position of -3.25 mm). In contrast to Fig. 12, Fig. 14 is drawn by using linear scale for y-axis.

Change of parameters  $Q_i$  and  $n_i$  in Fig. 14 with the file tip displacement can be explained by a change of the file-solution double-layer area when file is moving deeper into the solution inside the tapered root canal. The value of  $R_c$  is being reduced because the remaining length of root canal is shorter when file is deeper in the canal.

In the region between -2.50 and -0.75 mm the value of  $R_c$  decreased linearly with file position. When the file reaches -0.75 mm, the value of  $R_c$  rapidly decreases as the file is being scrolled through the apical constriction. After the root canal is wider again (above -0.5 mm), resistance continues to decrease with the previous rate. This behavior can be used to estimate the current position of the file inside the root canal.



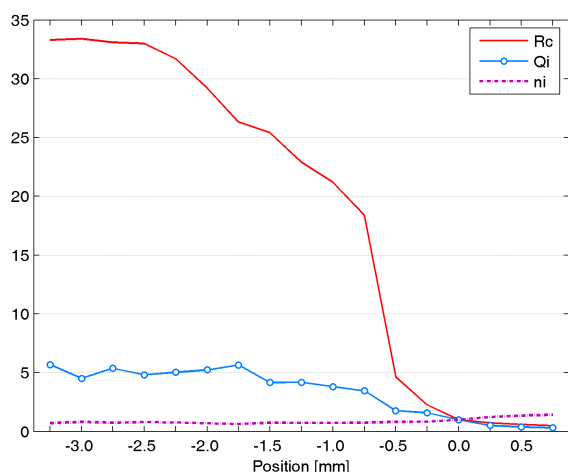

Fig. 14. Normalized parameters of circuit E using fixed values of  $Q_w$ ,  $n_w$  depending on the file tip position

Unfortunately during real endodontic procedure, the change of  $R_c$  with the file displacement inside the root canal strongly depends on the wideness of the root canal and the conductivity of the electrolyte that is present in the canal [8,13,16,17]. Therefore, the value of  $R_c$  and its slope is not sufficient to estimate the file tip position. It is important to determine which irrigant is present in the canal and accordingly compensate the values of  $R_c$ . For this purpose further investigation is required to determine the influence of different irrigants and root canal anatomy on the parameters of equivalent circuit E. It is also encouraged to find which parameter of equivalent circuit E, or perhaps some other equivalent circuit could be used to confidently determine which one of the most commonly used irrigants in endodontic treatment is currently present in the root canal.

## 8 DISCUSSION

The most critical procedure in the endodontic treatment is the measurement of the root canal length commonly performed by electronic apex locators.

A novel operating principle for root canal measurement devices that involves impedance spectroscopy is currently under investigation. A human tooth is modeled by electrical equivalent circuit whose elements are fitted to reconstruct the true measured impedance. Based on obtained values of equivalent circuit elements conclusions are made about the position of the file inside the root canal. Therefore using correct equivalent circuit is essential.

Eight equivalent circuits were compared by CNLS fitting procedure.

*Fitting quality* and *normalized fitting quality* factors were defined in order to compare individual equivalent circuit at each file tip position separately and in entire range of

measured frequencies (100 Hz to 1 MHz). Normalization was performed by using the number of free circuit parameters to account for the circuit complexity. *Overall circuit fitting efficiency* and *normalized overall circuit fitting efficiency* were also defined to allow for objective and quantitative evaluation of equivalent circuit ability to represent the true measured impedance in a given range of the file positions. For that purpose four weighting windows were defined and used to weight the overall circuit fitting efficiency:

1. inside the root canal,
2. around the apex (i.e. clinically the most important region),
3. in the overapex region and
4. in the entire region of file positions.

Fitting performances and the ability of estimated parameters to describe the file position inside the root canal were discussed for each equivalent circuit.

In this paper we have presented four new equivalent circuits with improved characteristics, namely C, D, E and H, Fig 3-5.

We have found that circuit C has improved fitting performances near the apex and the circuit D was better for all positions. Circuit E showed significant improvement of fitting performances inside the root canal, but has shortcomings in overapex region.

We have shown that a good fitting performance of an equivalent circuit is desirable, but it does not necessarily imply accurate determination of the apex.

Equivalent circuit H has shown the best fitting performances (in normalized manner) inside the root canal, but could not be used for measuring the file tip position due to its complex structure. The same obstacle kept circuit F from being used for that purpose.

## 9 CONCLUSION

The best choice for the determination of the file position was equivalent circuit E, proposed in this paper for the first time. Due to its simplicity it led to an unambiguous determination of all important elements.

A simplified method for the calculation of circuit E parameters and a new measurement procedure for the determination of the file position inside the root canal were proposed.

Further investigation of the influence of different tooth anatomy and irrigants that are commonly used in endodontic treatment on the elements of equivalent circuit E is required. Also, development of a new method to detect the presence of such irrigants is advisable.

## REFERENCES

- [1] D. Ricucci, "Electronic Apex Locators - Apical limit of root canal instrumentation and obturation, part 1," Literature review, *Int Endod J*, vol. 31, pp. 384-393, 1998.
- [2] J.A. Kang, S.K. Kim, "Accuracies of seven different apex locators under various conditions," *Oral Surg Oral Med Oral Pathol Oral Radiol Endod*, vol. 106, pp. 57-62, 2008.
- [3] C. Haffner et al., "Accuracy of electronic apex locators in comparison to actual length—an in vivo study," *Journal of Dentistry*, vol. 33, pp. 619-625, 2005.
- [4] M.P. Gordon, N.P. Chandler. "Electronic apex locators," Literature review, *Int Endod J*. vol. 7, pp. 425-427, 2004.
- [5] I. Sunada, "New method for measuring the length of the root canal," *Journal of Dental Research*, vol. 41/2, pp. 375-387, 1962.
- [6] M.H. Nekoofar et al., "The fundamental operating principles of electronic root canal length measurement devices," Review article, *Int Endod J*, vol. 39, pp. 595-609, 2006.
- [7] J.I. Ingle, et al, "Endodontic cavity preparation," in J.I. Ingle, L.K. Bakland (eds), *Endodontics*, 5th ed. Baltimore: Williams & Wilkins, pp.517-22, 2002.
- [8] Z. Stare, J. Šutalo, N. Galić, "The effect of apical foramen and electrode diameter on the accuracy of electronic root canal measuring devices," in *Proceedings of the 8th International IMEKO Conference on Measurement in Clinical Medicine*, (Zagreb, Croatia), pp. 533-536, 1998.
- [9] Y. Goel et al., "A comparative evaluation of the accuracy of third generation electronic apex locator (Root ZX) in presence of various intracanal irrigants," *Endodontology*, *Pub. Ind. Endodon. Soc.* vol. 18/1, pp. 28-33, 2006.
- [10] T. Marjanović, Z. Stare, "Benefits and disadvantages of impedance-ratio measuring method in new generation of apex-locators," in *IFMBE Proceedings 16*, pp. 206-209, 2007.
- [11] E. Barsoukov, J.R. Macdonald, *Impedance spectroscopy: theory, experiment, and applications*. placeCityHoboken, StateNew Jersey: John Wiley and Sons Inc., 2005.
- [12] T. Marjanović, Z. Stare, I. Lacković, "Verification of physical models used for root canal measurement by impedance comparison," in *IFMBE Proceedings 17*, pp. 715-718, 2007.
- [13] Z. Stare, T. Protulipac, "Sensitivity of the Root Canal Impedance to Electrode Displacement – in vivo and in vitro Measurement," in *Measurement Proceedings of the 4th International Conference*, (Smolenice, Slovak Republic), pp. 230-233, 2003.
- [14] T. Protulipac, Z. Stare, "The influence of excitation current on the root canal length measurement," in *Proceedings of the International Federation for Medical & Biological Engineering*, (Vienna, Austria), pp. 140-141, 2002.
- [15] Z. Stare, I. Lacković, N. Galić, "Evaluation of an in vitro model of electronic root canal measurement," in *Proceedings of the 9th Mediterranean Conference on Medical and Biological Engineering and Computing*, (Pula, Croatia), pp. 1047-1050, 2001.
- [16] D. Križaj, J. Jan and V. Valenčić, "Modeling AC Current Conduction Through a Human Tooth," *Bioelectromagnetics*, vol. 25, pp. 185-195, 2004.
- [17] J.H. Huang, S.C. Yen and C.P. Lin, "Impedance Characteristics of Mimic Human Tooth Root Canal and Its Equivalent Circuit Model," *Journal of The Electrochemical Society*, vol. 155, no. 5, pp. 51-56, 2008.

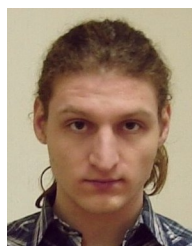

**Tihomir Marjanović** was born in Osijek, Croatia, in 1980. He received his B.Sc. and M.Sc. degrees in 2004 and 2009 in electrical engineering from the University of Zagreb, Faculty of Electrical Engineering and Computing in Croatia, where he works as a Junior Researcher. He is currently writing his Ph.D. thesis in the field of biomedical engineering. His interest also includes electronic instrumentation and embedded microcontroller system development.



**Igor Lacković** was born in Karlovac, Croatia, in 1972. He received the B.Sc., M.Sc. and Ph.D. degrees in electrical engineering from the University of Zagreb, Croatia. He is currently an Assistant Professor with the Faculty of Electrical Engineering and Computing, University of Zagreb. His main research interests are in the field of biomedical engineering with a special focus on numerical modeling of electric and thermal field distribution for electroporation-based drug and gene delivery, bioimpedance and related instrumentation development.



**Zoran Stare** was born in Zagreb, Croatia, in 1944. He received the B.Sc., M.Sc., and Ph.D. degrees in electrical engineering from the Faculty of Electrical Engineering and Computing, University of Zagreb, Croatia, in 1967, 1978, and 1997, respectively. He was an Associate Professor with the Department of Electronic Systems and Information Processing, Faculty of Electrical Engineering and Computing, University of Zagreb. His teaching and research interests are focused on electronic instrumentation, measurement techniques, industrial electronics, embedded systems and biomedical engineering.

## AUTHORS' ADDRESSES

**Tihomir Marjanović, M.Sc.**  
**Asst. Prof. Igor Lacković, Ph.D.**  
**Prof. Zoran Stare, Ph.D.**  
**Department of Electronic Systems and Information Processing,**  
**Faculty of Electrical Engineering and Computing,**  
**University of Zagreb,**  
**Unska 3, HR-10000, Zagreb, Croatia**  
**email: tihomir.marjanovic@fer.hr, igor.lackovic@fer.hr,**  
**zoran.stare@fer.hr**

Received: 2010-11-18

Accepted: 2011-02-18