

RESEARCH ON THE POWER GRID OPERATION IMPROVEMENT BY STATIC VAR COMPENSATORS

Vitomir Komen, Mateo Blasina, Renato Čučić

Original scientific paper

The paper investigates the impact of a static VAR compensator on voltage circumstances and reactive power flows in a Croatian power transmission grid. The research has been conducted between Melina SS–reversible Velebit HEPP–Konjsko SS under low- and high-load conditions of the system. During the research, the possibility of higher transfer capability of the existing HV overhead lines was identified through the reactive power flow control on the grid. Today's degree of industrialization and the living standards require exceptionally high quantities of electric energy, which is a great problem for the existing transmission systems having insufficient capacity to meet the increasing needs and demands of customers. The key parameters for solving the problems are the line transfer capability, voltage stability and reactive power compensation, which could be improved in terms of their high capabilities and better control by means of SVC devices.

Keywords: reactive power compensation, increase in transfer capability, power transmission grid, voltage control, SVC device and system stability

Istraživanje poboljšanja rada prijenosne mreže primjenom statičkih VAR kompenzatora

Izvorni znanstveni članak

U radu je istražen utjecaj statičkog VAR kompenzatora na naponske prilike i tokove jalovih snaga u Hrvatskoj prijenosnoj mreži. Istraživanje je provedeno između TS Melina–RHE Velebit–TS Konjsko i to u uvjetima niskih i visokih opterećenja sustava, te su utvrđene mogućnosti povećanja prijenosne moći postojećih visokonaponskih vodova kroz regulaciju i upravljanje tokova jalovih snaga u mreži. Današnji stupanj industrijalizacije i razvoja životnog standarda stanovništva iziskuje izrazito velike količine električne energije, što predstavlja veliki problem postojećim prijenosnim sustavima kao nedovoljno snažnim da zadovolje rastuće potrebe i zahtjeve kupaca. Ključni parametri za rješavanje navedenih problema su prijenosna moć voda, stabilnost napona i kompenzacija jalove snage, a povećanje i regulaciju istih moguće je ostvariti uz pomoć SVC uređaja.

Ključne riječi: kompenzacija jalove snage, povećanje prijenosne moći, prijenosne mreže, regulacija napona, SVC uređaj i stabilnost sustava

1 Introduction

A progressive growth in electricity demand and increasingly demanding customers ask for rehabilitation of the current transmission system as to provide a safe and good quality electricity supply and maintain the system stability. Worn out equipment and overloaded transmission lines can cause outages and blackouts in large industrial centres, and as a possible consequence, high financial losses. The basic problem reflected in the transmission system, not adequately supported by investments in increasing the transfer capability, could therefore reach a dangerous limit of its stability [1].

Not only are too high loads an issue, but also the low load conditions of the transmission elements, which could result, due to the prevailing parallel capacities of the lines, in serious damages in the switchgears. The current global financial crisis and implementation of the electricity market liberalization (the transfer from monopolistic to private-entrepreneurial system) particularly affect the system stability. This is manifested by underinvestment in all electric power sectors due to the numerous risks private investors are facing, such as huge investments and long-term return on investments, high costs and potential problems during construction and operation. The basic aim of power system development is secure supply of electricity at competitive prices formed on the open market with the appropriate environmental protection. Liberalized electricity market has allowed private investors to invest in renewable energy sources, which usually have a negative effect on system stability [1, 3, 4]. The problems made the world's scientific and professional communities more interested in maintaining the system stability and increasing the line transfer capability, voltage and reactive power control being the essential parameters of stability.

Current use of Flexible Alternating Current Transmission Systems (FACTS) helps in solving a great many previously mentioned situations. They are all cost-demanding and do not require replacement of the existing transmission lines by the new and more powerful ones.

The essence of all FACTS devices is in using the power electronic circuits, whose abrupt development over the last twenty years has resulted in formation of FACTS. The Static Var Compensators (SVC) are considered the first FACTS devices parallel-connected to the grid. This paper analyses the SVC devices, their properties, and operational problems when connected to a part of the Croatian electric power grid.

2 Structure and analysis of the SVC devices

A SVC device is counted among the parallel-connected FACTS devices whose main purpose is to control the voltage at the point of connection to the grid by injecting reactive power (current) into that node. Depending on whether it acts on the voltage amount in the node or on its angle, it is possible to achieve simultaneous effect on the active and reactive power flows in the system.

If the aim is the generation or consumption of the reactive power, the current injected should be phase vertical with respect to the voltage in the SVC connection node. Otherwise, the consequence will be the occurrence of the active power. The FACTS devices actually make the control of the transmission line current possible, which results in higher transfer capability. The generation or consumption of reactive power by SVCs varies widely using in most cases thyristor-controllable fluctuating impedances (capacitors and/or reactors). The power thyristors are found to be the most suitable because they involve significant voltage and current loads. Consequently, the types of thyristors are:

- Silicon Controlled Rectifiers (SCR)

- Gate Turn-off Thyristors (GTO)
- Metal-oxide Semiconductor Controlled Thyristors (MCT).

If a silicon-controlled rectifier is in a blocking state and if a positive impulse is brought to the "gate", SCR goes to a control state and maintains that state until the current through the main circuit (anode-cathode) falls to zero. This is the basic shortcoming of SCR because the control process cannot be voluntarily broken by a negative impulse to the "gate" thus making full controllability. That is why the GTO thyristors have been invented. They are fully controllable switches and have an optional on/off switching possibility. Finally, in order to increase the thyristor switch-off current, an MCT thyristor has been designed, which is in essence similar to GTO but has some advantages.

The SVC structure is illustrated in Fig. 1. It has been achieved by a combination of a thyristor-controlled reactor (TCR) and a thyristor-switched capacitor (TSC) with the filters for elimination of higher harmonics, which is in line with the standard design of SVC [2].

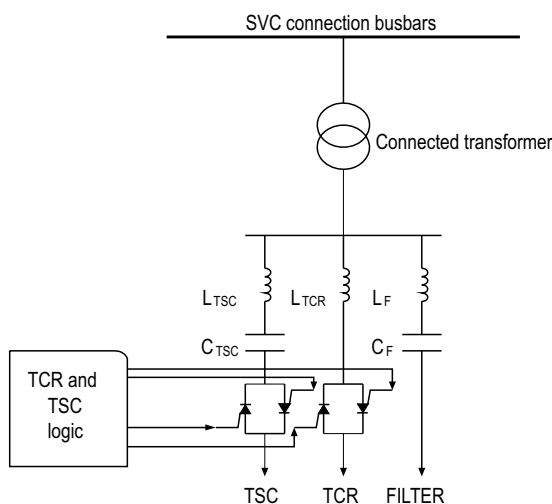

Figure 1 SVC device structure

Sensitive semiconductor elements require the SVC devices to be connected to the power grid through current transformers but a connection through a tertiary of a three-winding transformer is also possible providing it is cost efficient.

A wide range of control (inductive and capacitive character), fast response, low losses, insensitivity to the changes of voltage and frequency, continuous control, and independent phase control are the result of mass worldwide use of the SVC devices in electric power systems over the last ten years. Exceptionally high reliability of the SVC device operation has fully rolled out the use of conventional synchronous compensators and other conventional devices for voltage and reactive power control and the technological progress in the power electronics field made them competitively superior.

The climate-change related situations, environmental protection, market deregulation, and energy security force us into the reorganization of the systems and significant capital investment in renewable energy sources and distributed generation of electricity. This makes the SVC devices, but all other FACTS devices as well, leading in their use for maintaining the system stability and the quality of electric energy affected by the distributed electricity sources [3, 4].

2.1

Stationary characteristic of the SVC devices

In order to form stationary characteristics of a SVC device, its connection to an ideal transmission line is considered. Under ideal circumstances, SVC should be connected in the middle of the transmission line as illustrated in Fig. 2 [2, 5, 6].

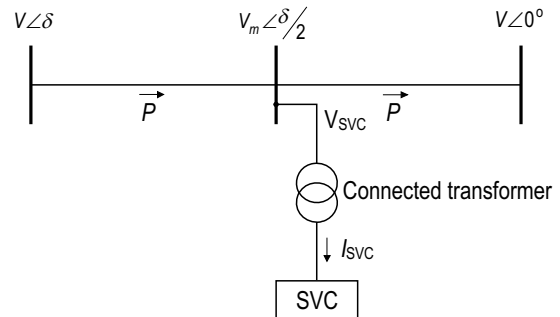

Figure 2 SVC device connected in the middle of a transmission line

With no SVC device connected as illustrated in Fig. 2, the amount of voltage in the middle of an ideal transmission line could be expressed as:

$$V_{m0} = \frac{V \cdot \cos(\delta / 2)}{\cos(\Theta / 2)}, \tag{1}$$

where Θ is an absolute weighting constant (wave constant) for the line length d and is expressed by the equation:

$$\Theta = \beta \cdot d, \tag{2}$$

with the parameters:
 β – phase constant, °/km
 d – line length, km.

Since an ideal line is involved, the following relations apply:

$$r = 0, \tag{3}$$

$$g = 0, \tag{4}$$

$$c \neq 0, \tag{5}$$

$$l \neq 0, \tag{6}$$

$$\beta = \omega \cdot \sqrt{l \cdot c} = 2 \cdot \pi \cdot f \cdot \sqrt{l \cdot c}, \tag{7}$$

where
 r – unit active resistance of the line, Ω /km
 g – unit active feeder of the line, S/km
 c – unit capacity of the line, F/km
 l – unit inductance of the line, H/km
 ω – circular frequency of the grid, rad/s
 f – operating frequency, Hz.

Since the voltage largest fluctuation occurs in the middle of the transmission line (according to the angle β), the SVC device can limit the fluctuation by adequate thyristor control of TCR and TSC.

The stationary control characteristic of SVC devices determines the relation between the SVC device voltage (V_{svc}) and the current injected by SVC (I_{svc}). The control characteristic of SVC and the system (transmission line)

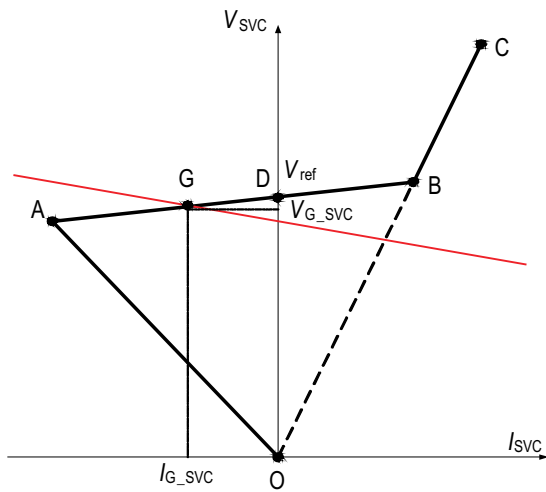

Figure 3 The stationary characteristic of the SVC device and the system characteristic

characteristic are illustrated in Fig. 3 to establish a relation between the system and the SVC electric parameters, the control area and the working point position.

The OABC curve represents a stationary characteristic of the SVC device (bolded black), whereas the system characteristic is shown by a straight line of negative inclination (red). The OA segment is an area in which SVC reaches a capacitive limit and the BC segment is a part of the characteristic where SVC gets into the inductive area and reaches an inductive limit. The inclination OA is defined by the capacitive susceptance of TSC B_{CTSC} , whereas the inclination BC is represented by the inductive susceptance B_{LTCR} TCR. The control area is defined by the line segment ADB, where the point G represents working point defined by intersection of the system and the SVC device characteristic.

The SVC current is considered positive when the susceptance of the SVC device B_{SVC} is inductive:

$$I_{SVC} = -B_{SVC} \cdot V_{SVC} \tag{8}$$

According to Fig. 3, the system characteristic is expressed by a linear equation of negative inclination:

$$V_{SVC} = V_T - X_T \cdot I_{SVC} \tag{9}$$

$$V_T = V_{m0} = \frac{V \cdot \cos(\delta / 2)}{\cos(\Theta / 2)} \tag{10}$$

$$X_T = \frac{Z_n}{2} \cdot \tan(\Theta / 2) \tag{11}$$

where

V_T – Thevenin voltage viewed from the SVC busbar side, kV

X_T – Thevenin reactance viewed from the SVC busbar side SVC, Ω

Z_n – Wave resistance of the ideal line, Ω .

The wave resistance of the line is represented by the equation:

$$Z_n = \sqrt{\frac{l}{c}} \tag{12}$$

In order to establish a relation among the electrical circumstances with and without a SVC device connected in the middle of the transmission line, the SVC voltage relations should be defined in the control area as shown in Fig. 3 (segment ADB of the line) and in parts of device stationary characteristic where the capacitive and inductive limits are reached (segments OA and BC).

According to Fig. 3, the ADB area is expressed by the equation:

$$V_{SVC} = V_{ref} + X_S \cdot I_{SVC} \tag{13}$$

where X_S is the quantity of the control area inclination of SVC, and V_{ref} is the SVC voltage for which I_{SVC} assumes the zero value according to the stationary characteristic in Fig. 3.

Having combined the equations (9) and (13), a relevant expression for V_{SVC} is obtained:

$$V_m = V_{SVC} = \frac{(V_T \cdot X_S) + (V_{ref} \cdot X_T)}{X_S + X_T} \tag{14}$$

However, the most important parameter is the line transfer capability. If $V_{ref} = V$ is assumed, the following expression for the line transfer capability is obtained:

$$P = t \cdot P_0 + (1 - t) \cdot P_1 \tag{15}$$

where the parameters are defined by:

$$P_0 = \frac{V^2 \cdot \sin \delta}{Z_n \cdot \sin \Theta} \tag{16}$$

$$P_1 = \frac{V^2 \cdot \sin(\delta / 2)}{Z_n \cdot \sin(\Theta / 2)} \tag{17}$$

$$t = \frac{X_S}{X_S + X_T} \tag{18}$$

The equation (15) suggests that the line transfer capability becomes higher if using SVC devices considering part of the equation $(1 - t) \cdot P_1$ where:

P_0 – line transfer capability with no SVC device connected in the middle, MW or pu

P_1 – line transfer capability with SVC connected in the middle of the transmission line and maintaining the constant voltage value V at the connection point, MW or pu.

The marginal areas of the stationary characteristic (Fig. 3) could be expressed by fixed susceptance B_{SVC} :

$$B_{SVC} = B_{CTSC} \tag{19}$$

when SVC reaches the capacitive margin (segment OA), and:

$$B_{SVC} = -B_{LTCR} \tag{20}$$

when SVC reaches the inductive margin (segment BC).

If the expression for I_{SVC} from the equation (8) is incorporated in the equation (9), a relation for V_{SVC} in marginal areas of the SVC stationary characteristic is obtained:

$$V_{SVC} = \frac{V \cdot \cos(\delta/2)}{(1 - X_T \cdot B_{SVC}) \cdot \cos(\Theta/2)} \quad (21)$$

In that case, the following relation applies for the line transfer capability:

$$P = \frac{V^2 \cdot \sin \delta}{Z_n \cdot (1 - X_T \cdot B_{SVC}) \cdot \sin \Theta} \quad (22)$$

In the equations (21) and (22), the parameter B_{SVC} assumes the values from the relations (19) and (20) depending on whether SVC reaches capacitive or inductive margin.

**2.2
TCR as a SVC structure element**

Power thyristors are controlled by the reactor current L_{TCR} and the TCR control time [2,7]. The basis of the control is the thyristor trigger angle α . Dependent on the requirements imposed on SVC, the trigger (firing) angle ranges from 180° to 90° . The TCR current movement is determined by the control angle σ (dependent on the trigger angle), which could constantly change from 0° to the maximum value corresponding to 180° angle.

The relation between the trigger and the control angles could be expressed by the equation:

$$\sigma = 2 \cdot (\pi - \alpha) \quad (23)$$

The TCR current is non-sinusoidal and as such, it contains higher harmonics that could be integrated in an extremely complex relation:

$$I_n = \frac{V}{X_L} \cdot \frac{4}{\pi} \cdot \left[\frac{\sin \alpha \cdot \cos(n\alpha) - n \cdot \cos \alpha \cdot \sin(n\alpha)}{n \cdot (n^2 - 1)} \right] \quad (24)$$

$n = 2 \cdot k + 1; k = 1, 2, 3, \dots$

where
 n – higher harmonics, –
 V – effective value of connected voltage, kV
 X_L – reactor reactance L_{TCR} of basic frequency, Ω .

Higher (odd) harmonics affect the current injected by SVC, which requires installation of additional filters to cancel the negative impact of higher harmonics on the system and on the consumers as well.

The basic component of the TCR current depends on the control susceptance B_{LTCR} and the control angle σ , which could be expressed by the equation:

$$I_1 = B_{LTCR}(\sigma) \cdot V \quad (25)$$

where the control susceptance is expressed as:

$$B_{LTCR}(\sigma) = \frac{\sigma - \sin \sigma}{\pi \cdot X_L} \quad (26)$$

**2.3
TSC as a SVC structure element**

Switching (on/off) parallel capacitors is done by the power thyristors and the result therefore is a step change of

reactive power injected into the AC system. This is the basic disadvantage as compared to TCR featuring continuous control. However, the TCR's advantage is in the fact that it does not inject higher harmonics into the system and the injected current is not distorted [2, 7].

Since large quantities of current flow through the capacitor when it is connected to the AC system, in order to protect the power thyristors an additional reactor L_{TSC} should be connected in the series with C_{TSC} (Fig. 1) to limit the current and prevent the thyristor damage. Another reason for connecting an additional reactor is to prevent the resonance with an AC grid. An optimal value of the reactor is determined by the reactance root ratio of X_{CTSC} and X_{LTSC} according to the equation:

$$r = \sqrt{\frac{X_{CTSC}}{X_{LTSC}}} \quad (27)$$

where
 X_{CTSC} – reactance of the TSC transversal capacitor, Ω
 X_{LTSC} – reactance of the TSC additional reactor, Ω

The amount of reactor L_{TSC} is selected by taking $r > 3$ for the factor r .

**2.4
Higher harmonics and protection of SVC devices**

SVC is considered a generator of higher harmonics in the system [2, 8], which is first of all due to the implementation of TCR in the SVC structure being the first to blame for generation of higher harmonics. Another consequence of injecting distorted currents by TCR is distorted voltage at the point of the SVC connection. Most of the problems refer to generation of low frequency harmonics that can cause serious problems in terms of electricity quality and stability of the system.

Generally, SVC contains filters for elimination of the 3rd, 5th, and 7th order harmonics. The higher harmonics amplitude primarily depends on the thyristor valve switching frequency. A transformer connected to the SVC device (Fig. 1) solves the problem of the third-order harmonics. The star-delta connection prevents that the third-order harmonics enter the AC system. For other harmonics, different filter structures are used (combinations of capacitors, reactors and resistance; passive and active filters) depending on the place of the SVC device installation and the funds available.

The use of a 12-impulse configuration of TCRs is also possible (TCR divided into two sections), which results in penetration of the 15th order and higher (odd) harmonics. However, this structure requires more capital. As a rule, the 15th order (and higher) harmonics are disregarded because they hardly have any impact on the electrical quantities at the SVC device connection point.

Since the basis of all FACTS devices is power electronics, each element requires adequate protection. This primarily refers to the power thyristors, which are very sensitive to different voltage and current overloads, temperature overloads, and similar. Basic defects related to power thyristors are:

- Thyristor failed to trigger at the right moment,
- One thyristor, or the whole section, failed to trigger,
- Voltage and current (temperature) overloads of thyristors, and
- Mechanical damage of thyristors.

The use of the break-over diodes (BOD) for automatic triggering of thyristors could solve the problem if a thyristor (a single one or the whole section) fails to trigger.

TRCs could be divided into two sections with the thyristor switches connected in the middle of the sections. In such way, the short circuit is prevented throughout the TCR device and it is very unlikely that the short circuit will happen at the same time in both sections. This design is typical for a 12-impulse configuration of TCR, which is financially more expensive.

Adequate cooling solves the problems relating to the temperature overloads. Cooling by water has proved to be the best solution.

Among other defects that could affect the operation of the SVC devices, the most significant are:

- Short circuits close to SVC
- Surge loads
- Short circuit within SVC.

The surges could be restricted by the metal-oxide varistors limiting the overvoltage to the desired value in a very simple way.

2.5

Cost specification

Cost specification considers the capital costs by generated kVAr, a level of operating costs of each device that could participate in voltage, and the reactive power control in the electric power system. Determination of the generation costs or the reactive power consumption in the electric power system is very complex and a number of criteria should be taken into account. The market liberalization further complicates the situation because of the additional services necessary for a normal and stable operation of the system (primary and secondary control of voltage and reactive power, cold and spinning reserve and similar). The problem is in charging these additional services to the single generators in the system. With the market liberalization, this could be any electricity undertaking satisfying the conditions prescribed [9].

When analyzing the costs of generation and consumption of the reactive power (capital and operating costs), the grid compensation devices taken into account are synchronous compensators, capacitor banks, SVC devices and other FACTS compensators (STATCOM-Static Synchronous Compensators, UPFC-Unified Power Flow Controller, and TCSC-Thyristor Controlled Series Capacitor). A comparison of the devices with respect to the capital costs (in \$/kVAr(kW)) is shown in Tab. 1 [9].

Table 1 Comparison of capital costs for conventional and FACTS devices

Type of device	Capital costs / \$/kVAr(kW)
Synchronous compensator	35 ÷ 50
Capacitor bank	10
SVC	35 ÷ 45
STATCOM	50 ÷ 55
UPFC (series branch)	(50)
TCSC	40

The reason for wide use of the SVC devices is their relatively low operating costs and exceptionally high operating reliability. The SVC compensator could achieve

at the same time the following:

- Voltage control and reactive power compensation
- Swing attenuation in the system
- Restriction of higher harmonics in the system
- Compensation of asymmetries in the system
- Higher stability of the system and the transfer capability.

As previously noted, the consequence of the SVC advantages is mass use of the devices in the transmission systems regardless of slightly higher capital costs per generated kVAr (Tab. 1).

3

Connection of the SVC device to a section of the EPS transmission grid: Melina SS – reversible Velebit HEPP – Konjsko SS

The impact of the SVC devices on electrical circumstances in a 400 kV transmission grid section (400 kV) of the electric power system connecting two basic substations was analysed: Melina SS and Konjsko SS with the reversible Velebit hydroelectric power plant (HEPP) connected (Fig. 4). Two generator sets have been installed in the reversible Velebit HEPP. They are designed to meet the requirements of the turbine and pumping operation. The sets in the model are defined to satisfy the turbine operation at fixed output that is available apparent power of 155 MVA per each set and the power factor of 0,89. According to Fig. 4, the grid consists of three 400 kV busbars (nodes) (Melina SS, the reversible Velebit HEPP, and Konjsko SS), two overhead lines connecting the nodes (Melina SS – Velebit HEPP and Velebit HEPP – Konjsko SS), the reversible Velebit hydroelectric power plant with two generator sets connected to a 400 kV grid with the associated transformers, and a stiff grid connected to the busbars in Konjsko SS. The energy transfer is in the east-west direction i.e. from Konjsko SS to Melina SS.

All lines in the model in Fig. 4 are characterized by their length, operating voltage, reactance, susceptance, and the maximum allowed current under regular mode of operation (maximum apparent power).

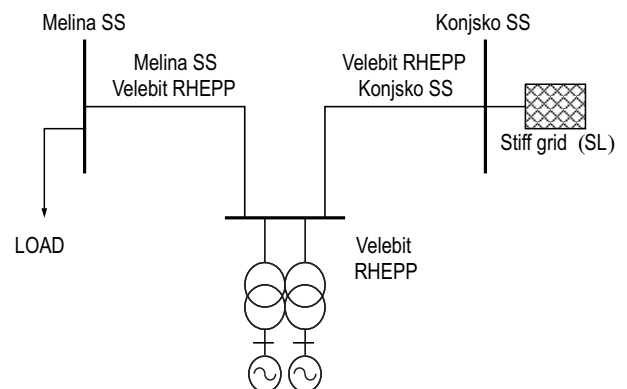

Figure 4 A model of the analyzed transmission grid

The transformers are defined by apparent power, transmission ratio, short circuit voltage, magnetizing current, short circuit losses and idle operation, control capabilities, and the connection group.

The synchronous generators in the power plants are represented by the rated apparent power, rated power factor, rated and minimal active power, maximal and minimal

reactive power according to the operating chart of the hydro set, and the associated reactances in the longitudinal and transversal axis.

The load is connected on the Melina SS side because of the east-west energy transfer and is modelled with the required active and reactive power (PQ). On the other side, a stiff grid is connected to the busbars in Konjsko SS making possible to cover the grid losses but also the power supply to consumers (load in Melina SS) with the necessary quantity of active and reactive power taking into account also the output of the reversible Velebit HEPP. At the connection point, the stiff grid maintains the voltage at 1,05 p.u.

Tab. 2 shows the amounts of voltage in each grid node with the operating conditions (loads) defined, and with no SVC device connected.

Table 2 Voltages in the grid nodes according to the loads defined

LOADS		Melina SS	Rev. Velebit HEPP
P / MW	Q / MVar	U / kV	U / kV
100	10	441,34	437,73
200	20	435,38	435,57
300	40	425,55	431,80
400	65	412,33	426,54
500	70	401,74	421,83
600	75	387,92	415,53
700	80	368,78	406,69
800	85	336,89	392,01

It is understood from Tab. 2 that at the low load connected to Melina SS, the voltages in the nodes assume too high and consequently do not allow values particularly in Melina SS. The higher the amount of load in the system, the lower is the amount of voltages in the nodes, which creates a problem of too small amounts of voltages in the nodes (Melina SS in particular). The problem is solved by adequate control of voltage and reactive power in the system for which a SVC device could be used since this is its fundamental purpose.

3.1 Results of the analysis with a SVC device connected in Melina SS

In order to have adequate voltages in each grid node, a SVC device consisting of a thyristor-controlled reactor (TCR) and two thyristor-switched capacitors (TSC) was used. The SVC is modelled with 300 MVar maximum reactive power of TCR and two TSCs of the reactive power of 150 MVar / capacitive. In order to maintain the exact amount of voltage of 400 kV (1,00 p.u.) at the SVC connection point (Melina SS), a balanced control was selected. The SVC device transformer and additional filters eliminating the harmful effect of higher harmonics of distorted injected current by SVC have been disregarded.

Tab. 3 shows the voltages in each grid node provided with the SVC device in Melina SS. Tab. 4, Tab. 5, Tab. 6, and Tab. 7 show the calculation of the power flow through the present lines, Melina SS – Velebit HEPP and Velebit HEPP – Konjsko SS with and without the SVC device connected.

Tab. 3 also shows the amounts of reactive power (MVar) injected into the grid by the SVC device (or taken from the grid) to maintain the voltage at the connection point at the exactly desired and predefined amount. In such a

Table 3 Voltages in the grid nodes according to the loads defined with the SVC device connected

LOAD		Melina SS	Velebit HEPP	SVC device
P / MW	Q / MVar	U / kV	U / kV	Q / MVar
100	10	400	423,41	166,37
200	20	400	423,32	140,34
300	40	400	422,94	98,45
400	65	400	422,24	45,48
500	70	400	421,22	6,140
600	75	400	419,84	-39,97
700	80	400	418,08	-93,35
800	85	400	415,91	-154,68

way, the voltages in the neighbouring grid nodes are also stabilized with respect to the SVC connection point.

The voltage circumstances, with or without the SVC device, are illustrated in Fig. 5. Under the condition of the system low load, the voltages in Melina SS and in the reversible Velebit HEPP assume high values. Likewise, when the system load increases, the voltages in the same nodes fall due too high flows of the reactive power. The SVC device reduces the flows and because it is connected to the Melina SS node, it takes from and gives to the grid a certain amount of the reactive power, which results in voltage stabilization in the broader region and in the nearby nodes respectively. Since the SVC device is connected at the Melina SS node, it maintains a constant amount of voltage at that node in accordance with its control model. Fig. 5 shows the lowest amount of voltage in Melina SS due to the identified reactive power flows in the associated grid model.

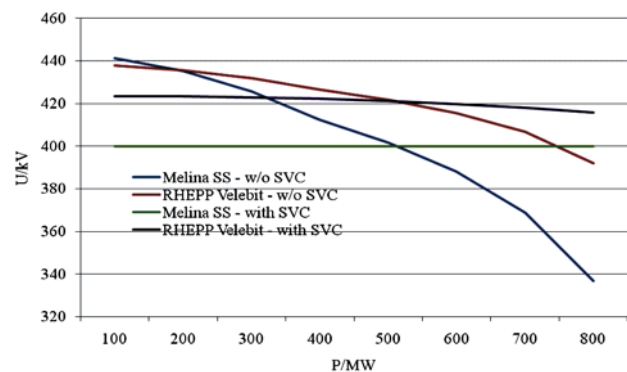

Figure 5 Voltage circumstances with and without a SVC device

In order to have the exact voltage of 400 kV at the Melina SS busbars, the SVC device injects into the grid a certain amount of reactive power. The consequence of the lower grid loads are high amounts of voltage in the grid and vice versa. The control of reactive power flow acts on the amount of voltage in each grid node, which is manifested through the SVC device operating area with respect to the static characteristic according to Fig. 3. The limit value of the load at which the SVC device gets from the inductive to the capacitive area is 516 MW / 70 MVar. The SVC device current for this grid load value is zero, and consequently, there is no injection of reactive power into the grid. The SVC device operates in the inductive area in case of any lower grid load. In contrast, in case of any higher value of the loads with respect to the reference value, the SVC device gets into the capacitive area of operation.

Table 4 Transmission line flow from Melina SS – Velebit HEPP with no SVC device connected

LOAD		Melina SS – Velebit HEPP			
		Melina SS		Velebit HEPP	
P /MW	Q /MVar	P /MW	Q /MVar	P /MW	Q /MVar
100	10	-100	-10	100,38	-80,44
200	20	-200	-20	201,39	-58,90
300	40	-300	-40	303,23	-18,31
400	65	-400	-65	406,13	38,57
500	70	-500	-70	510,10	84,97
600	75	-600	-75	615,60	147,11
700	80	-700	-80	723,51	233,82
800	85	-800	-85	836,81	375,81

Table 5 Transmission line flow from the reversible Velebit HEPP – Konjsko SS with no SVC devices connected

LOAD		Velebit HEPP – Konjsko SS			
		Velebit HEPP		Konjsko SS	
P /MW	Q /MVar	P /MW	Q /MVar	P /MW	Q /MVar
100	10	174,58	185,55	-173,3	-237,2
200	20	73,57	163,79	-72,86	-220,9
300	40	-28,27	122,79	28,68	-182,7
400	65	-131,19	65,32	131,63	-124,1
500	70	-235,16	18,37	236,14	-70,44
600	75	-340,67	-44,54	342,71	5,00
700	80	-448,59	-132,4	452,47	114,36
800	85	-561,93	-276,5	569,37	299,74

Table 6 Transmission line flow from the reversible Velebit HEPP – Konjsko SS with the SVC devices connected

LOAD		Melina SS – Velebit HEPP			
		Melina SS		Velebit HEPP	
P /MW	Q /MVar	P /MW	Q /MVar	P /MW	Q /MVar
100	10	-100	-176,37	101,17	105,07
200	20	-200	-160,34	202,22	99,20
300	40	-300	-138,45	304,06	95,12
400	65	-400	-110,48	406,70	92,88
500	70	-500	-76,14	510,20	92,60
600	75	-600	-35,03	614,61	94,40
700	80	-700	13,35	720,00	98,46
800	85	-800	69,68	826,46	104,99

Table 7 Transmission line flow from Velebit HEPP – Konjsko SS with SVC devices connected

LOAD		Velebit HEPP – Konjsko SS			
		Velebit HEPP		Konjsko SS	
P /MW	Q /MVar	P /MW	Q /MVar	P /MW	Q /MVar
100	10	173,77	-1,54	-173,25	-55,80
200	20	72,72	4,31	-72,61	-66,19
300	40	-29,11	8,36	29,16	-70,95
400	65	-131,76	10,51	132,09	-69,88
500	70	-235,27	10,67	236,24	-62,74
600	75	-339,68	8,70	341,69	-49,20
700	80	-445,07	4,43	448,52	-28,80
800	85	-551,53	-2,38	556,86	-0,96

In order to satisfy the load requirements connected to Melina SS, the voltages, without adequate control, assume the values not allowed and accordingly the reactive power flow through both transmission lines becomes too high (Tab. 4 and Tab. 5). To achieve a 400 kV voltage at Melina SS, the SVC device injects a certain quantity of reactive power into the system (depending on the load connected) thus influencing the reactive power flows in the system and it compensates them (Tab. 6 and Tab. 7), which results in the voltage stabilization in the neighbouring grid nodes.

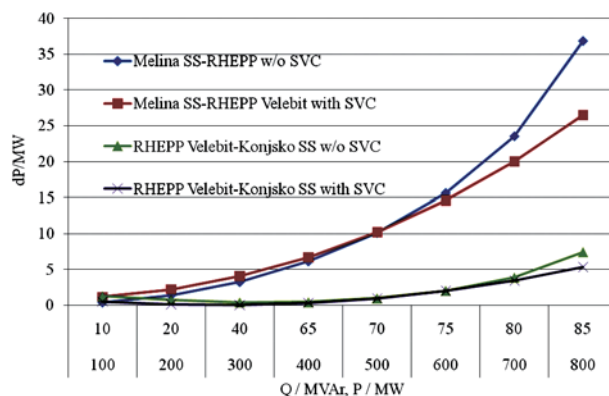

Figure 6 Active power losses on the lines in the model

By increasing the load in Melina SS, the losses through both transmission lines decrease (SVC gets from the inductive to the capacitive mode of operation), which is readily observable on the transmission line Melina SS – Velebit HEPP because a SVC device is connected to the Melina SS node (Fig. 6).

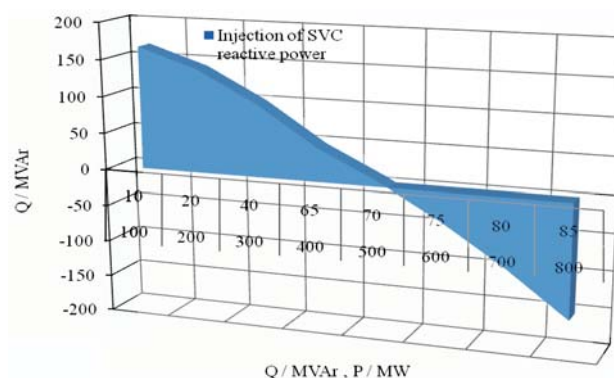

Figure 7 Area of the SVC device operation in the model

Depending on the grid load, the SVC device injects into or takes the reactive power from the grid and thus maintains the constant voltage value in Melina SS (Fig. 7). For the load value of 516 MW / 70 MVar, the SVC device current is zero and therefore there is no injection of the reactive power into the grid as illustrated in Fig. 7 (border area of the SVC device operation).

4 Conclusion

The research analysed the operation of the SVC devices on the transmission grid experiencing the problems of too high voltages due to too low loads flowing through the lines. The research showed that the SVC devices could influence:

- the voltages at the SVC device connection point by controlling the reactive power flow through the grid,
- the active power losses on the transmission lines decreasing with the increase in the system load,
- the increase in the line transfer capability i.e. the increase in the limiting transfer capability of the lines.

When the system is under the highest load, the transmission lines analyzed could be loaded by 28,4 % more with respect to the initial state with no SVC connected. The losses alongside the line are decreased by the same percentage value. For the load value of 516 MW and 70 MVar, the SVC device goes from the capacitive area, where SVC injects the reactive power into the connection node, to

the inductive area in which the reactive power is used, and is followed by a relevant increase in the system load.

The positive effect of the SVC device is demonstrated at high loads, but also at the system low loads as noted in the paper. Since Dalmatia is facing a problem of high loads at 400 kV and 220 kV voltage levels, due to the low loads of the lines, the use of the SVC devices could be ideal for solving the problem. Furthermore, deregulation of the electricity market and ongoing increase in electricity consumption (sufficient and good quality electric power), in the near future, it is also possible to expect the increase in the transmission line loads. Also in this scenario, the use of the SVC devices (or some other FACTS devices) could be pivotal for solving the upcoming problems.

5

References

- [1] Metodologija i kriteriji za planiranje razvoja prijenosne mreže u uvjetima otvorenog tržišta električnom energijom / autori studije Mislav Majstrovic, Davor Bajs, Goran Majstrovic. Zagreb: Energetski institut "Hrvoje Požar" d.o.o., 2002.
- [2] Padiyar, K. R. FACTS Controllers in power transmissions and distribution. New Age International Publishers, New Delhi, 2007.
- [3] Višković, A. Svjetlo ili mrak: O energetici bez emocija. Akademija tehničkih znanosti Hrvatske, Lider press d.d., Zagreb, 2008.
- [4] Višković, A. Svjetlo ili mrak: Energetska sigurnost – političko pitanje. Akademija tehničkih znanosti Hrvatske, Lider press d.d., Zagreb, 2009.
- [5] Sharma, P. R.; Kumar, A.; Kumar, N. Optimal Location for Shunt Connected FACTS Devices in a Series Compensated Long Transmission Line. // Turk J Elec Engin. 15, 3(2007), pp.321-328.
- [6] Nwohu, M. N. Voltage Stability Improvement using Static Var Compensator in Power Systems. // Leonardo Journal of Sciences. ISSN 1583-0233, Issue 14, January–June 2009. pp. 167-172.
- [7] Dizdarević, N. Mogućnosti povećanja prijenosne moći EES-a korištenjem konvencionalnih i FACTS naprava. // Energija. 50(2001), 5, str. 323-348
- [8] Grigsby, L. L. Power Systems. Taylor & Francis Group LLC, Canada, 2007.
- [9] Plavšić, T.; Kuzle, I. Regulacija napona i jalove snage kao pomoćna usluga sustava. // Energija. 54(2005), 5, str. 385-387.

Authors' addresses

doc. dr. sc. Vitimir Komen, dipl. ing. el.

Faculty of Engineering
University of Rijeka
Vukovarska 58
51000 Rijeka, Croatia
e-mail: vitimir.komen@hep.hr

Mateo Blasina, BScEE

Faculty of Engineering
University of Rijeka
Vukovarska 58
51000 Rijeka, Croatia
e-mail: mblasina@gmail.com

Renato Ćučić, BScEE

HEP-ODS d.o.o., Elektroprimorje Rijeka
V. C. Emina 2
51000 Rijeka, Croatia
e-mail: renato.cucic@hep.hr