

Bernd-Robert Hoehn, Karsten Stahl, Klaus Michaelis

ISSN 0350-350X

GOMABN 51, 1, 5-28

Izvorni znanstveni rad / Original scientific paper

LUBRICANT INFLUENCE ON SLOW SPEED WEAR IN GEARS

Abstract

In gears running under conditions of high load and low circumferential speed the lubricant film thickness is often not sufficient to fully separate the mating surfaces. Wear of the gear flanks can occur and can even result in total gear failure. For a given gear geometry the main influencing parameters are load, circumferential speed and lubricant. The wear characteristics of lubricants depend on many factors. Viscosity, base oil type and additives have great influence. In slow speed gears mostly lubricants with anti-wear (AW) additives reducing wear by forming chemical and/or physical protection layers are used. For testing the wear capacity of lubricants a suitable test method was developed using a modified FZG back-to-back gear test rig. The FZG slow speed wear test C/0.05/90:120/12 is run under very low circumferential speeds of $v = 0.05$ m/s and 0.57 m/s and at two different test temperatures $\vartheta_{oil} = 90$ °C and 120 °C. The test consists of three parts and is run in several intervals. The complete test run takes 120 h. The test gears are of C-PT type, the same as for the FZG pitting test.

Since the development of the test many different lubricants of different fields of application were investigated. The test results show obvious differences. Linear, degressive and progressive wear rates were found. Lubricants of the same base oil type and the same viscosity even with the same type of additive can totally differ in their wear behaviour. Also at different temperatures the wear performance of lubricants can be different. Due to activation of additives some lubricants show decreasing wear rates with increasing temperature whereas for other lubricants the temperature seems to have no influence. With the test method C/0.05/90:120/12 a suitable tool for the determination of the wear behaviour of lubricants is available. Candidate lubricants can be discriminated and ranked according to their wear characteristics under mixed and boundary lubrication conditions. The results of the slow speed wear test can be introduced into a calculation method. This calculation method allows the evaluation of the expected wear rate in a gear in practice when operated with the tested lubricant. An exemplary recalculation of the wear damage in a railway gearbox showed close correlation between calculation and practice. Substantial improvements were achieved by using a lubricant with better wear performance which was evaluated in the slow speed wear test.

1. Introduction

In order to decrease the no-load losses and thus to increase gear efficiency lubricants of low viscosity are commonly used. This results in thin film thickness values between the mating gear surfaces. This effect is even more relevant at high operating temperatures, among other reasons caused by small total lubricant quantities for low churning losses. In slow speed gears mixed and boundary lubrication can occur under high load so that the mating surfaces are not fully separated. In this case chemically or physically effective additives must help to reduce wear of the sliding surfaces.

Wear means the continuous removal of material from the surface of a solid body, caused by mechanical reasons, that means contact and relative motion of a solid, fluid or gaseous mating body [4]. Referred to gears wear means a continuous removal of material from the tooth flanks with each mesh what leads to increasing profile deviations from the original flank geometry. With ongoing wear damage dynamic effects as well as other gear damages can occur. In drives with high demands of accuracy, e.g. in robotics or azimuth gears, wear and the resulting increase of the flank clearances can cause the total failure of the drive component.

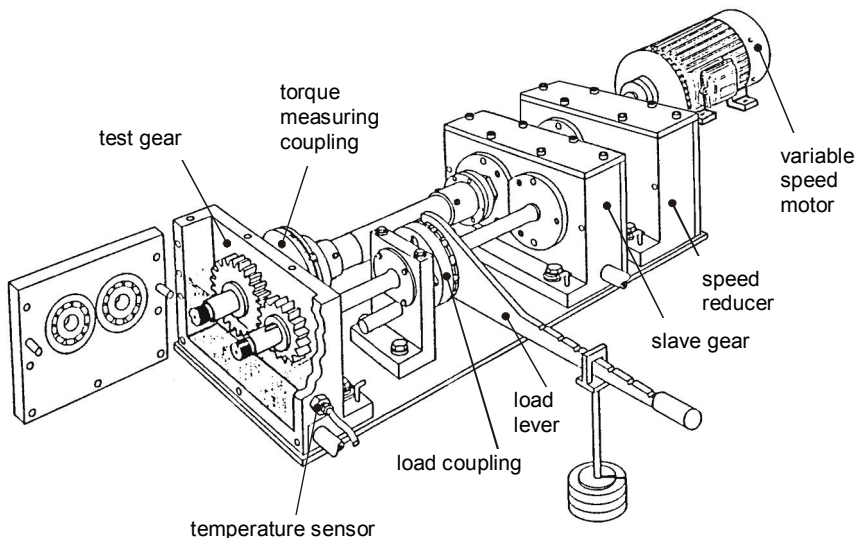

Figure 1: Modified FZG gear test rig

For the determination of the wear characteristics of gear lubricants only the ASTM wear test A/0.57/120/10 [1] was available. This test was developed for the determination of the wear behaviour of tractor hydraulic fluids and thus higher viscous lubricants can typically not be discriminated.

Therefore the influence of lubricants on wear occurring in slow speed gears was systematically investigated in different research projects [2,6,8]. The FZG wear test method C/0.05/90:120/12 was developed [3]. The test is performed in a modified FZG back-to-back gear test rig and gives detailed information on the wear protecting capabilities of lubricants at two different temperatures under conditions of mixed and boundary lubrication.

2. Test Method

2.1 Test Rig and Test Gears

The test is performed in a modified FZG back-to-back gear test rig with an additional speed reducer as shown in Figure 1. Same test gears FZG C-PT are used as for the FZG pitting test. The main data are given in Table 1.

Table 1: Main data of test gears type C

		symbol	unit	value
center distance		a	mm	91.5
number of teeth	pinion	z_1	-	16
	gear	z_2	-	24
module		m	mm	4.5
pressure angle		α	°	20
helix angle		β	°	0
face width		b	mm	14
profile shift factor	pinion	x_1	-	0.1817
	gear	x_2	-	0.1715
working pitch diameter	pinion	d_{w1}	mm	73.2
	gear	d_{w2}	mm	109.8
tip diameter	pinion	d_{a1}	mm	82,5
	gear	d_{a2}	mm	118.4
material		MAT	-	16MnCr5
heat treatment		-	-	case carburized

2.2 Test Conditions

A test run with one lubricant consists of 3 parts, consecutively run on the same gear flank. The test conditions are given in Table . Part 1 and 2 only differ in oil temperature. In part 3 the influence of speed is investigated. Alternatively the conditions of part 1 or 2 can be repeated in part 3. The test is performed at oil dip lubrication. The wear of the gears is determined after each test interval by separate weighing of pinion and gear. Compared to the operating conditions of most gears in practice the test conditions are very severe. Thus a discrimination of lubricants with improved wear characteristics can be achieved within a relatively short test time.

A transfer of the test results to conditions of gears in practice can be achieved by the calculation method according to Plewe [7].

Table 2: Test conditions

Test Conditions	Part 1 C/0.05/90/12	Part 2 C/0.05/120/12	Part 3 C/0.57/90/12
Pitch line velocity	0.05 m/s	0.05 m/s	0.57 m/s
Pinion speed	13 rpm	13 rpm	150 rpm
Gear speed	8.7 rpm	8.7 rpm	100 rpm
Oil sump temperature	90 °C	120 °C	90 °C
Pinion torque	378.2 Nm	378.2 Nm	378.2 Nm
Hertzian stress at pitch point	1853 N/mm ²	1853 N/mm ²	1853 N/mm ²
Running time	2 x 20 h	2 x 20 h	1 x 40 h
Number of revolutions of gear	2 x 10400	2 x 10400	1 x 240000

3. Influencing Parameters

Different lubricants from the market place were investigated. These lubricants were from different applications, had different base oils and additive systems and different viscosity grades. The main data of these lubricants are summarised in Table 3.

Table 3: Lubricants

Base Oil	Application	Code	Grade	Additive	Viscosity at 40°C	Viscosity at 100°C
Min	ATF	Dexron D	ISO VG 32	S-P + Ca	38 cSt	7,1 cSt
Min	engine oil	engine oil	SAE 30	ZDTP	99 cSt	12,0 cSt
Min	engine oil	engine oil	SAE 50	ZDTP	204 cSt	19,1 cSt
Min	MTF	GL-4	SAE 90	S-P	220 cSt	18,7 cSt
Min	MTF	GL-4	SAE 140	S-P	460 cSt	30,3 cSt
Min	axle oil	GL-5 man1	SAE 80W	S-P	108 cSt	11,4 cSt
Min	axle oil	GL-5 man2	SAE 80W90	S-P	137 cSt	14,0 cSt
Min + PAO	axle oil	GL-4	SAE 75W90	S-P	108 cSt	16,0 cSt
Min	tractor oil	UTTO	ISO VG 46	ZDTP	66 cSt	9,3 cSt

3.1 Temperature and Viscosity

With increasing temperature the viscosity of lubricants decreases and thus also the film thickness. Therefore increasing wear is expected for increasing temperature. Figure 2 shows the results of wear tests at constant circumferential speed $v = 0.05$ m/s for different oil temperatures.

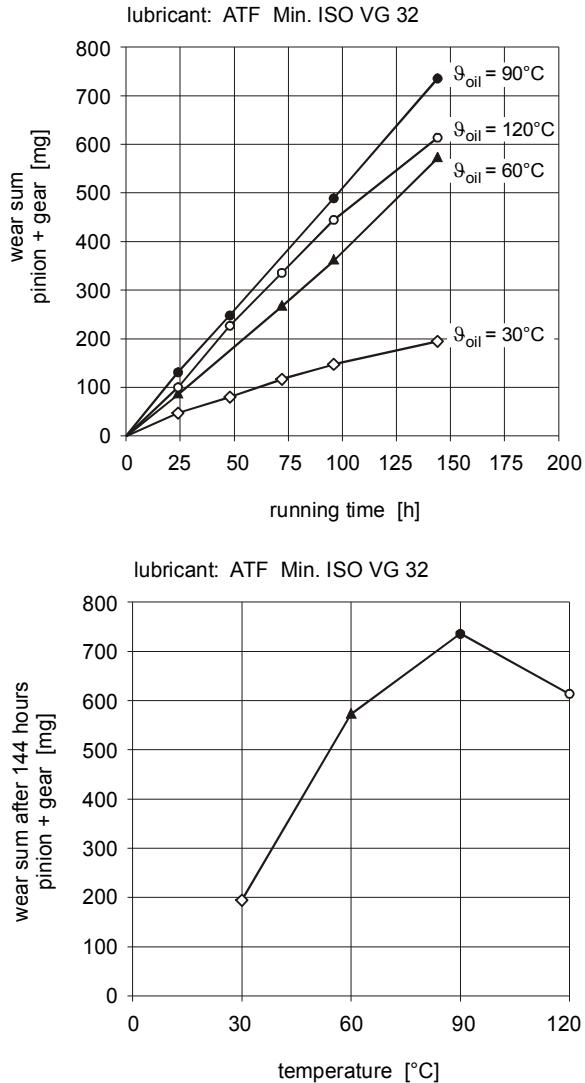

Figure 2: Influence of temperature on slow speed wear

With increasing oil temperature the wear increases for the candidate lubricant. At $\vartheta_{oil} = 90\text{ }^{\circ}\text{C}$ the highest wear amount is found, at $120\text{ }^{\circ}\text{C}$ less wear occurs. The reason for this effect lies in the decreasing influence of temperature on viscosity when temperature increases and additionally in the influence of temperature on the activity of the additives. With increased temperature the additives can be more active and improved wear protection can be found.

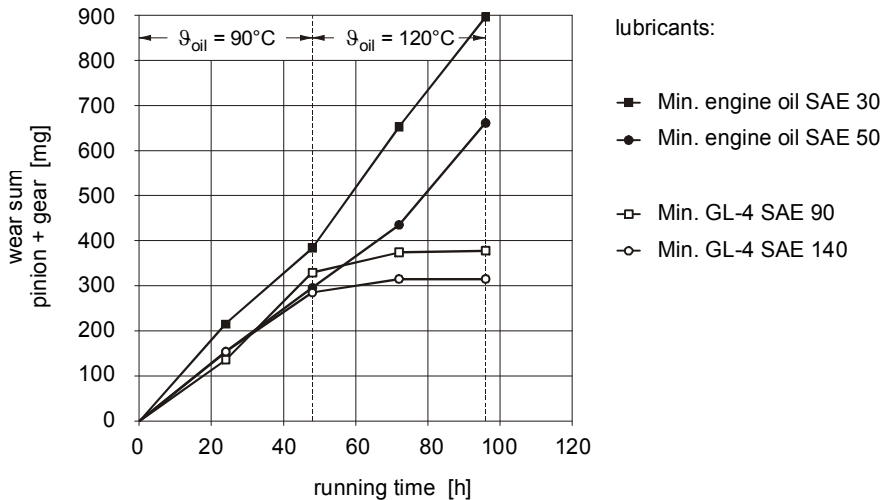

Figure 3: Influence of viscosity and temperature on slow speed wear

The influence of viscosity and temperature is also demonstrated in Figure 3. It shows the wear curves of two engine oils and two gear oils each with different viscosities. Each pair of lubricants shows the same wear behaviour. As expected higher viscosity results in lower wear. For the engine oils there is hardly any influence of temperature on the wear characteristics. With higher temperature slightly higher wear rates are found. For the gear oils there is a strong influence of temperature on the wear rates. Whereas at $90\text{ }^{\circ}\text{C}$ high wear is detected almost no wear occurs at $120\text{ }^{\circ}\text{C}$. The additives seem to be active at higher temperature and effectively reduce wear at this condition.

3.2 Additives

Under mixed and boundary lubricating conditions the additives have a substantial influence on the wear characteristics of a lubricant. Figure 4 shows the wear curves of two mineral oils of API class GL-5 of different manufacturers 1 and 2. The lubricants are each blended with sulphur-phosphorous additives and have similar viscosities. For oil temperature $\vartheta_{oil} = 90\text{ }^{\circ}\text{C}$ and circumferential speed $v = 0.05\text{ m/s}$ the wear characteristics are totally different whereas at higher temperature and higher speed very similar wear behaviour is found.

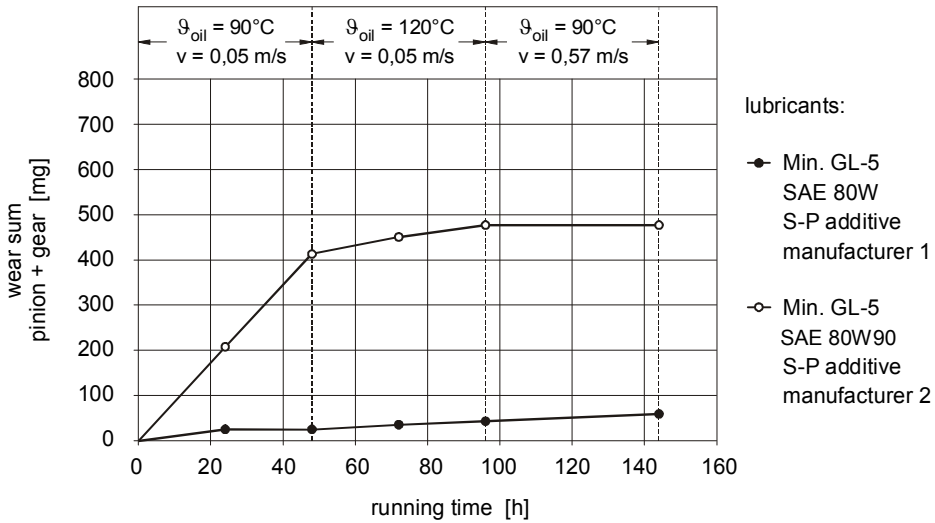

Figure 4: Influence of additive on slow speed wear

4. Application

4.1 Discrimination of Lubricants

With the FZG test method C/0,05/90:120/12 lubricants can be discriminated according to their wear behaviour. Figure 5 shows examples of different lubricants from different fields of application.

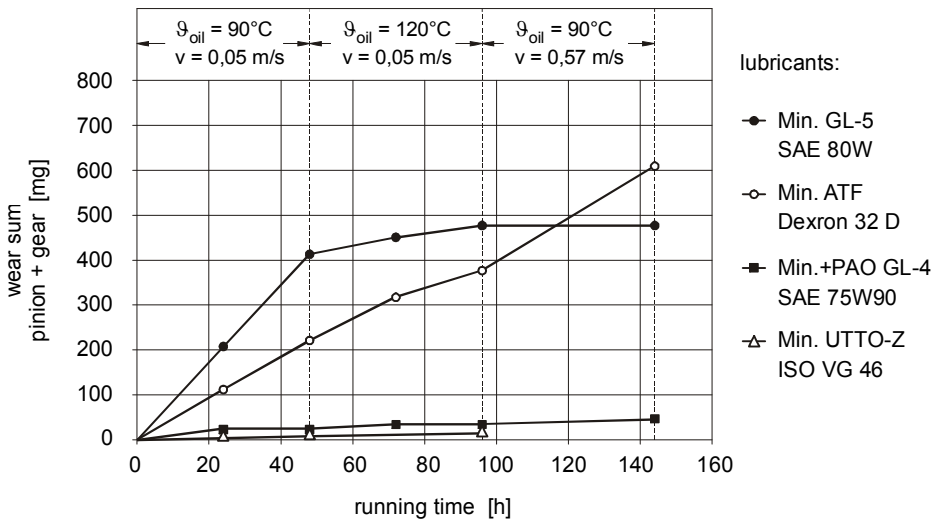

Figure 5: Discrimination of lubricants according to their wear characteristics

The wear rates of the lubricants vary from low wear to high wear. For some oils the wear behaviour strongly depends on the test conditions whereas for other oils no such influence can be found. It is obvious that a prediction of the wear rate of different lubricants only with the knowledge of the oil type, viscosity or additive system without testing can hardly be successful.

4.2 Wear Calculation

For the transfer of the results of the FZG slow speed wear test to actual operating conditions of a gear in practice a suitable calculation method is available. According to Plewe [7] the linear wear amount W_l of gear flanks after a given number of load cycles can be calculated from:

$$W_l = c_{IP} \cdot \left(\frac{\sigma_H}{\sigma_{HT}} \right)^{1.4} \cdot \left(\frac{\rho_C}{\rho_{CT}} \right) \cdot \left(\frac{\zeta_W}{\zeta_{WT}} \right) \cdot N \leq W_{lall} \quad (1)$$

with	W_l	[mm]	linear wear amount
	W_{lall}	[mm]	allowable linear wear amount
	c_{IP}	[mm/cycle]	linear wear coefficient at conditions of gear in practice
	σ_H	[N/mm ²]	nominal contact stress
	ρ_C	[mm]	radius of curvature at pitch point
	ζ_W	[-]	wear relevant specific sliding
	N	[-]	number of load cycles
	index T	[-]	values for test conditions

The linear wear amount W_l is the average thickness of the worn out material from the tooth flank. The removal of material is not uniform across the flank area. The maximum wear is expected in the middle between pitch circle and begin of contact respectively end of contact. The maximum wear is about three times the calculated linear wear amount W_l .

The decisive parameter in equation (1) is the linear wear coefficient c_{IT} . If no test results are available the value of a straight mineral oil according to Plewe [7] can be used. For case hardened gears it can be determined from Figure 6 by introducing the calculated film thickness at operating conditions. For a candidate lubricant with anti-wear or EP-additives the linear wear coefficient can be derived from the test results at $\vartheta_{oil} = 90 \text{ }^\circ\text{C}$ or $120 \text{ }^\circ\text{C}$ according to equation:

$$c_{IT} = \frac{m}{2 \cdot m_n \cdot b \cdot z \cdot \rho \cdot N} \quad (2)$$

with c_{IT} [mm/cycle] linear wear coefficient at test conditions, m [mg] wear amount, m_n [mm] normal module, b [mm] face width, z [-] number of teeth, ρ [mg/mm³] material density, and N [-] number of load cycles.

With the assumption that lubricants with anti-wear or EP-additives behave similar as pure mineral oils the original Plewe wear curve for a straight mineral oil is shifted parallel through the test point as shown in Figure 6. The test point is defined by c_{IT} and the film thickness h_{minT} at test conditions.

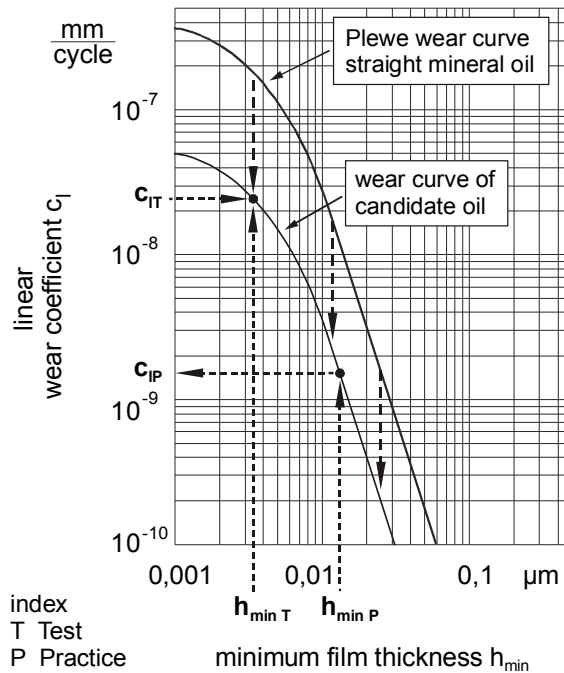

Figure 6: Linear wear coefficient

The relevant linear wear coefficient c_{IP} for the candidate lubricant can now be determined from the diagramme at the respective film thickness h_{minP} of the gear in practice. The film thickness h_{min} can be calculated according to Dowson/Higginson [5]. For sufficient wear load carrying capacity the calculated wear amount must be smaller than the allowable wear limit W_{all} . For the allowable wear different criteria can be applied depending on the gear design and application. In Figure 7 the allowable wear limits according to Plewe [7] are summarised.

4.3 Practical Example

Severe wear was found on pinions of locomotive gears used temporarily at severe conditions of high load and very low speed in trains for coal transport. Due to the deviations of the pinions increased vibrations occurred at higher speeds resulting in mechanical breakage and even engine damages. Figure 8 is a photo of a worn pinion. Severe wear marks can be observed.

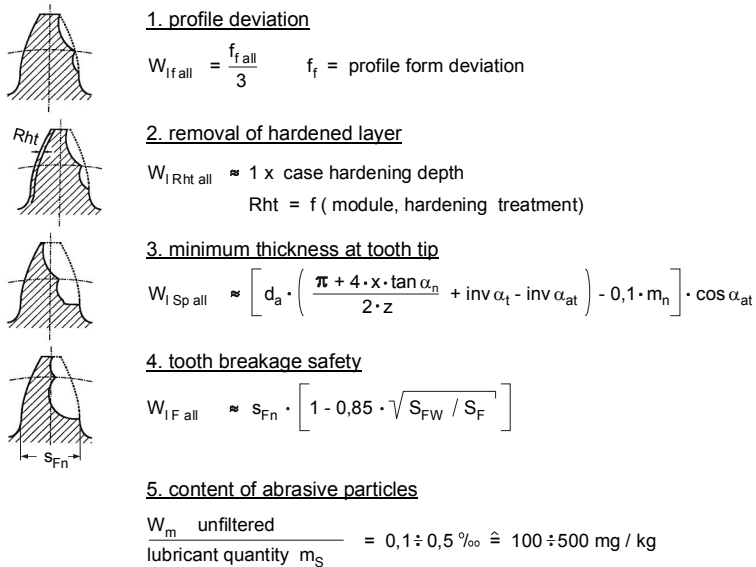

Figure 7: Allowable wear amount acc. to [7]



Figure 8: Worn locomotive pinion

Figure 9 shows the profile form measurement of three teeth of the right and the left flank of the worn pinion. The profile form deviations below the pitch circle due to wear are in a range of 50 to 80 μm .

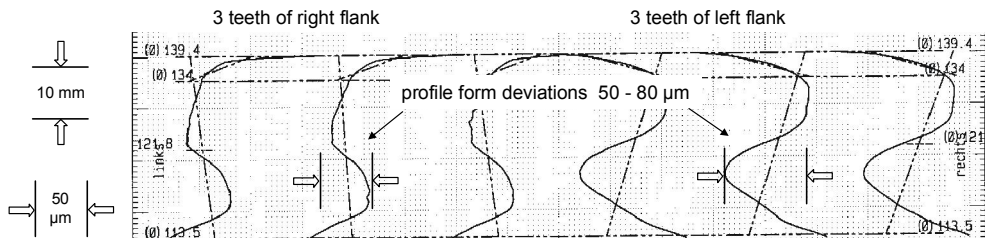

Figure 9: Profile form measurement of the worn pinion

The gear lubricant was a mineral oil ISO VG 220 blended with EP-additives. There was no information on the wear characteristics of the oil. Therefore a test according to the FZG slow speed wear test method C/0.05/90:120/12 was run and as a possible improvement an additional test with a polyglycol of the same viscosity class was performed. The viscosity data of the lubricants and the linear wear coefficients c_{IT} derived from the test results based on same film thickness $h_{min} = 0.01 \mu\text{m}$ are summarized in Table . For comparison the data of a straight mineral oil ISO VG 220 are additionally given. If compared to the straight mineral oil the EP mineral oil is characterised by improved wear behaviour. The polyglycol shows the lowest wear rate. Compared to the EP-oil only half the amount of wear is expected for the same film thickness. In addition the viscosity of the polyglycol at high temperature is higher than for the EP-oil due to the higher viscosity index VI. Thus the polyglycol provides a higher film thickness in the contact at high temperature despite its slightly unfavourable pressure-viscosity behaviour.

Table 4: Viscosity data and linear wear coefficients

	EP mineral oil ISO VG 220	polyglycol ISO VG 220	straight mineral oil ISO VG 220
v_{40} [mm ² /s]	215	219	220
v_{100} [mm ² /s]	19	38	19
VI [-]	99	226	97
c_{IT} [mm/cycle] at $h_{min} = 0.01 \mu\text{m}$	$20 \cdot 10^{-9}$	$10 \cdot 10^{-9}$	$50 \cdot 10^{-9}$

Measurements showed that in the contact the friction coefficient of polyglycols is in a range of only 50 to 70% of mineral oils. Therefore lower frictional heat and thus lower oil sump temperatures are expected when a polyglycol is used instead of a mineral oil. For the given application the oil sump temperature is assumed to decrease by some 10 K when using a polyglycol. Correspondingly at the same load the difference in film thickness of a polyglycol and a mineral oil is even increased. Taking all influence factors into account the film thickness and the expected wear after 2000 h at critical conditions were calculated for the mineral oils and the polyglycol. The results are shown in Table . The expected wear W_i of the polyglycol is reduced by a factor of approximately 5 when compared to the actually used EP mineral oil.

Table 5: Expected wear after 2000 h at critical operating conditions

$\vartheta_{oil \min} = 105 \text{ }^\circ\text{C}$ $\vartheta_{oil \text{ PG}} = 95 \text{ }^\circ\text{C}$ $v = 0.1 \text{ km/h}$	EP mineral oil ISO VG 220	polyglycol ISO VG 220	straight mineral oil ISO VG 220
h_{min} [μm]	0,004	0,008	0,004
c_{IP} [mm/cycle]	$70 \cdot 10^{-9}$	$15 \cdot 10^{-9}$	$250 \cdot 10^{-9}$
W_i [μm]	120	25	425

5. Conclusions

The wear characteristics of lubricants depend on many parameters. Viscosity, base oil type and additives as well as operating conditions have great influence. Lubricants of the same field of application can show substantial differences in wear characteristics. With the test method C/0.05/90:120/12 a suitable tool for the determination of the wear behaviour is available. Lubricants can be discriminated according to their wear characteristics under mixed and boundary lubrication conditions in a simple and cost effective manner. A calculation method is provided where the results can be transferred to actual conditions of any gears in practice.

References

- [1] ASTM Standard D 4998-89: Standard Test Method for Evaluating Wear Characteristics of Tractor Hydraulic Fluids, 1989.
- [2] Bayerdörfer, I.: Untersuchungen zum Einfluss von Schmierstoff und Betriebsbedingungen auf das Verschleißverhalten von Zahnrädern. DGMK Forschungsbericht Nr. 377-01, 1996.
- [3] DGMK Information: Method to Assess the Wear Characteristics of Lubricants - FZG Test Method C/0.05/90:120/12, 1997.
- [4] DIN 50323 Teil 2: Tribologie, Verschleiß, Begriffe, 1993.
- [5] Dowson, D.; Higginson, G. R.: Elastohydrodynamic Lubrication, Oxford, 1966.
- [6] Krieger, H.: Änderung des Verschleißverhaltens von Zahnrädern bei betriebsbedingten Ölveränderungen. DGMK Forschungsbericht Nr. 377-02, 2001.
- [7] Plewe, H.-J.: Untersuchungen über den Abriebverschleiß von geschmierten, langsam laufenden Zahnrädern. Dissertation TU München, 1980.
- [8] Vošiek, J.: Entwicklung eines Verfahrens zur Beurteilung des Verschleißverhaltens von Schmierstoffen für Zahnradgetriebe. DGMK Forschungsbericht Nr. 377, 1992.

Key words: lubricant, gears, slow speed wear, test method, calculation method

Authors

Bernd-Robert Hoehn, Karsten Stahl, Klaus Michaelis
e-mail: michaelis@fzg.mw.tum.de
Gear Research Centre FZG
Technische Universität München, Germany

Received

16.08.2011.

Accepted

08.01.2012.