

Carlos Restrepo, Tine Konjedic, Javier Calvente, Roberto Giral

A Review of the Main Power Electronics' Advances in Order to Ensure Efficient Operation and Durability of PEMFCs

DOI 10.7305/automatika.53-2.192
UDK 621.352.6
IFAC 4.2; 4.3

Original scientific paper

This article focuses on the main issues that affect the lifetime and performance of proton-exchange membrane fuel cells. The short lifespans of these fuel cells represent a barrier to their massive commercialization and usage in mobile and stationary applications. As fuel cell is a very complex system, a lot of knowledge of different areas is required, such as chemistry, electricity and mechanics, in order to completely understand its operation and all the problems that can occur during it. It is for this reason that an interdisciplinary approach needs to be taken when designing fuel-cell energy systems. This paper focuses on identifying and solving those issues that negatively affect the lifetime and performance of fuel cells. It is hoped that this article would be a valuable aid for power electronics' researchers and engineers for better understanding the presented issues and a useful guide for solving them with the use of proper power electronic-devices. Initially, the basic operation and structure of a proton-exchange membrane fuel cell is explained. Three main issues that can occur during operation of a mobile or stationary fuel cell energy system are pointed out and discussed in details, on the basis of the state-of-the-art on fuel cell technology. These issues are poor water management, reactant gas starvation and fuel cell current ripple. This article provides answers as to why they occur, how they affect the fuel cell, how they can be mitigated, and what are the future trends within this research field.

Key words: PEMFC, Water management, Reactant gas starvation, Current ripple, Power electronics.

Pregled znanstvenih napredaka u učinskoj elektronici usmjerenih ka osiguravanju efikasnog rada i dužeg životnog vijeka PEM gorivih ćelija. Članak se osvrće na ključna pitanja koja utječu na vrijeme rada i performanse gorivih ćelija s polimernom membranom kao elektrolitom. Kratak životni vijek gorivih ćelija takve vrste prepreka je njihovoj komercijalizaciji i masovnoj upotrebi u mobilnim i stacionarnim stanicama. Budući da su gorive ćelije komplicirani sustavi potrebno je znanje iz raznih područja kemije, elektrotehnike i mehanike da bi se u potpunosti mogao razumjeti njihov način rada i problemi koji se događaju. Upravo je zbog toga multidisciplinarni pristup nužnost pri razvoju sustava koji koriste gorive ćelije. Ovaj je članak usmjeren prema identifikaciji i rješavanju onih problema koji negativno utječu na životni vijek i performanse gorivih ćelija. Autori se nadaju da će se članak pokazati kao korisna pomoć i vodič istraživačima i inženjerima u domeni učinske elektronike pri susretu s navedenim problemima. Objasnjeno je način rada i struktura gorive ćelije s polimernom membranom kao elektrolitom. Izložena su, i diskutirana do u detalje, tri glavna problema sa stajališta trenutačnih spoznaja u području učinske elektronike. Ti problemi su: loše upravljanje vodom, nestanak reaktantnog plina i strujni trzaji u gorivim ćelijama. Objasnjeno je zašto se ovi problemi događaju, kako utječu na gorivu ćeliju, kako ih se može spriječiti i koje su buduće perspektive istraživanja.

Ključne riječi: PEM goriva ćelija, upravljanje vodom, nestanak reaktantnog plina, strujni trzaji, učinska elektronika

1 INTRODUCTION

Power systems based on proton-exchange membrane fuel cell (PEMFC) technology have been the object of increasing attention and extensive research over recent years. They are very interesting and display a lot of potential for usage in both stationary and mobile applications due to their high-efficiency, low-operating tempera-

tures, fast start-up, high-power density, solid electrolytes, longer cell and stack lifetime in comparison with other kinds of fuel cells, low corrosion rate, and non-polluting emissions [1–3]. However, the relatively short lifespans of fuel cells, in general, is a significant barrier to their commercialization in stationary and mobile applications [4–6].

Scientific literature discusses and deals with many different operational conditions and occurrences that affect

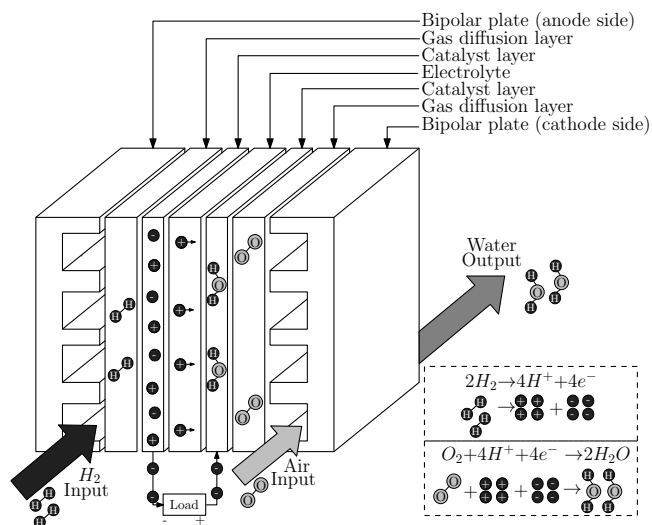

Fig. 1. Basic structure and chemical reactions of a PEMFC

the lifetime and performance of a fuel cell. This work is usually done either from chemical, mechanical or electrical points of view. There are many papers that discuss the impacts of such issues as poor water management, reactant gas starvation or fuel cell current ripple, on chemical reactions and components inside a PEMFC. However, there is no paper that would explain the ways of their mitigation from a power electronics' perspective. Therefore this article provides an overview of those above-mentioned issues that could cause irreversible damage to the PEMFC and the possibilities of mitigating or completely eliminating them with the use of novel power-electronic devices and approaches. This work provides a detailed explanation of possible causes for FC power degradation and a broad insight into a FC energy system, in which the FC is not treated as a black box. In addition, future work is suggested that would relate to mitigation of the discussed issues.

The basic operation principle and structure of a PEMFC is presented in Section 2. The further sections present and discuss three major problems that negatively affect the performance and lifetime of a FC and their possible solutions. Thus Section 3 describes the consequences of poor water management and ways of avoiding them, Section 4 explains the phenomenon of reactant gas starvation, and Section 5 the causes, effects and mitigation of FC current ripple. The last section collates the conclusions of this work.

2 PEMFC PRINCIPLE AND STRUCTURE

Fuel cells are electrochemical devices that directly convert the chemical energy of a fuel into electricity. FCs can operate continuously as long as they are provided with sufficient amounts of reactant gases. The reactant gases used by PEMFCs to produce electrical energy are hydrogen and

oxygen. The basic structure and chemical reactions of a PEMFC are depicted in Fig. 1. Hydrogen, in a gaseous state (H_2), enters into the fuel cell through the bipolar plates' channels on the anode side. These channels allow the distribution of gas uniformly through the entire surface of the gas diffusion layer. Then, the hydrogen molecule goes to the anode catalytic layer, where it is dissociated as electrons and protons

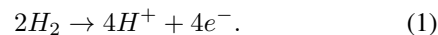

The electrons flow through the electric load to the catalytic layer of the cathode, whilst the protons travel through the electrolyte membrane. The membrane blocks the flow of electrons to the catalyst layer on the cathode side. On the other hand, the oxygen in a gaseous state (O_2) flows from the bipolar plates channels within the cathode to the catalyst layer of the cathode. Finally, the oxygen, the hydrogen protons and the electrons react to generate water onto the catalyst layer on the cathode side. The reaction is as follows

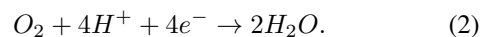

Each cell, as depicted in Fig. 1, generates low dc voltage and high dc current. In order to reach the power requirements of the load, as well as a sufficient level of dc voltage, it is necessary to connect individual FCs in series, what is known as a stack. The FC stack is a complex system that requires an auxiliary power-conditioning system to ensure safe, reliable and efficient operation under different operating conditions. In general, a PEMFC system includes four subsystems that manage the air, the hydrogen, the humidity, and the stack temperature, as shown in Fig. 2. The following sections present the main issues affecting the lifetime and performance of a PEMFC stack. In addition, ways are discussed for identifying, mitigating, and resolving them using power-electronics approaches.

3 POOR WATER MANAGEMENT

As described above, a FC is an efficient electrochemical energy source that combines hydrogen and oxygen to produce electricity, with heat and water as its by-products (2). One part of the water generated by the FC is removed out of the stack, whilst the other part is used to humidify the membrane. It is very important to keep the membrane humidified in order to ensure high proton (H^+) conductivity [7]. Nevertheless, excess water can block the flow-channels and the pores of the gas diffusion layer. This leads to a phenomenon known as gas starvation, as explained in the next section. In addition, excessive accumulation of water aggravates other degradation mechanisms such as the corrosion and contamination of components [8]. On the

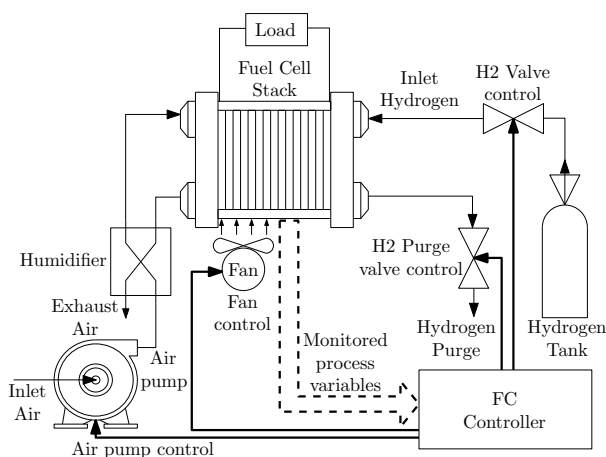

Fig. 2. PEMFC system with main control subsystems

other hand, dehydration of the membrane causes a decrease in proton conductivity and generates higher ohmic losses due to increased ionic resistance [7, 9, 10]. This results in a voltage drop and a reduction in output power. If a FC is operated under conditions of dehydration over a long period, the membrane can suffer severe and irreversible damage [7, 8, 11, 12]. In order to improve the performance and extend the lifetime of a FC, it is very important to maintain a balance between the amount of water kept inside the stack and the amount ejected from it [8, 11].

A basic FC energy system consists of a FC stack and, in most cases, a voltage step-up dc-dc converter. The latter has to ensure that the energy delivered by the FC can be used over a wide range of applications in a safe and efficient manner. Since the FC stack's structure is equivalent to a series connection of several voltage sources, each with its own internal impedance, the output power of the stack is limited by the state of the weakest cell [13, 14]. The fuel and air pressures, along with the membrane humidity, are the main parameters that can affect the terminal voltages of each cell. Those cells that receive lower pressure and/or have drier membranes will produce reduced voltage in comparison with other cells. Variations in fuel and air pressures can occur due to obstructions caused by bad FC water management. In addition, bad water management also causes variations in membrane humidity. The membrane humidities of each cell within the stack vary depending on the heat distribution within the FC. It is known that the heat is unequally distributed across the FC and that there are always differences in the temperatures of the central and side-cells of the stack. [15, 16]. An accumulation of excess water, known as flooding, may occur in the extremes of the stack, whilst the center of the stack, which is generally hotter, is susceptible to the appearance of membrane drying. A set of modular dc-dc converters that elec-

trically divides the FC stack into three sections, each powered by a modular dc-dc converter, is proposed in [13], in order to reduce the impacts of bad FC water management. The set of modular dc-dc converters presented in Fig. 3(a) has the following advantages [13]:

- The power generated by different sections within the modular fuel cell stack can be independently controlled by each dc-dc converter.
- Extra heating within under-performing sections of the stack due to their larger internal impedance, can be reduced by limiting their load currents. Thus reducing internal losses within the fuel cell.
- If a section of the stack is faulty, the dc-dc converter controlling the faulty section can be disabled and/or bypassed, whilst the rest of the system can continue operating at reduced power.
- If the proposed modular stack is employed in automotive systems, and a fault occurs whilst driving, the driver can steer the vehicle to a safe location under reduced power, since faulty stack sections can be shut-down.

Figure 3(b) shows a different topology than that used in [13], with the aim of reducing the impacts of bad FC water management and increasing the quality of the power generated by the FC. The advantage of the proposed topology is in the reduced sizes of the magnetic components, and improved global converter efficiency by the use of zero-voltage switching [14]. Both presented topologies achieve better performance of the FC, but do not reduce the impact of bad FC water management.

A novel, interdigitated gas distribution design has been studied by several researchers with the aim of improving the mass-transport rates of the reactants from the flow channels to the inner catalyst layers of the porous electrodes thus reducing the electrode water flooding problem in the cathodes of the PEMFCs [17–20]. Fig. 4(a) shows a conventional gas distribution design, in which the reactant gases are transported from the gas channels to the catalyst layers, mainly by diffusion. With the interdigitated flow field presented in Fig. 4(b), the transport mechanism is not only diffusion but also forced convection, which improves the mass transfer of reactant gases [19]. In addition, the shear force of this gas flow helps to remove a large amount of water in liquid state, that is entrapped in the inner layers of the electrode. This way the electrode flooding problem is significantly decreased [17, 18]. He *et. al.* [21] proposed using the pressure drop between the inlet and outlet channels as a diagnostic signal for monitoring the liquid water content within the porous electrodes of a PEMFC.

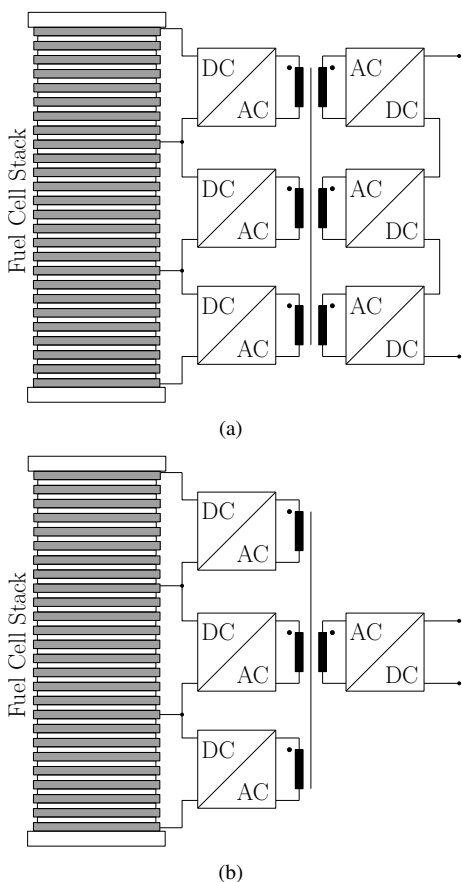

Fig. 3. Proposed modular fuel cell and modular dc—dc converter concept in: (a) [13], (b) [14]

This electrode-flooding monitoring device was designed for PEMFCs with interdigitated flow-distributors; however the authors claim that the presented methodology can be used for other flow-distributions as well. One of the drawbacks of this method is that it requires the installation of two pressure sensors at the entrance points of hydrogen and air, although these places are difficult to access in many commercial FCs.

The monitoring and control of flooding and drying-out conditions of a PEMFC and the characterization of both phenomena using AC impedance measurements, is presented in [22]. The state of the membrane humidification is controlled by the relative humidity of the inlet gases using a Fuel Cell Test Station of the Greenlight Innovation Manufacturer. Electrochemical impedance spectroscopy (EIS) is measured using the Gamry FC350 Fuel Cell Monitor in conjunction with an electronic load. The experimental EIS results are used to adjust the parameters of the Randles circuit with a constant phase element (CPE) and Warburg finite-length, as shown in Fig. 5.

The impedance of the equivalent circuit illustrated in

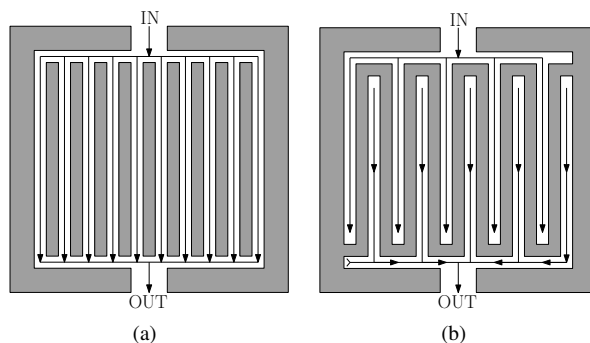

Fig. 4. Schematic illustrations of two different flow-fields: (a) conventional flow field design, (b) interdigitated flow-field

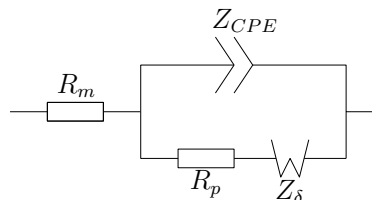

Fig. 5. Simplified equivalent electrical circuit schematic used in [22]

Fig. 5 is

$$Z = R_m + \frac{1}{(j\omega)^\alpha Q + \frac{1}{R_p + R_d \frac{\tanh(\sqrt{\tau_d j\omega})}{\sqrt{\tau_d j\omega}}}} \quad (3)$$

where R_m is the membrane resistance in $[\Omega]$, R_p the polarization resistance in $[\Omega]$, R_d the diffusion-related resistance in $[\Omega]$, ω the angular frequency in $[\text{rad s}^{-1}]$, α the power of the CPE set at 0.8, Q a constant parameter of the CPE in $[\Omega^{-1}(j\omega)^{-\alpha}]$, and τ_d the diffusion-related time constant in $[s]$. The main parameters of the FC, like temperature, current, pressures and stoichiometry relations, were kept constant during the study of FC behavior, whilst the relative humidity of the input gases changed over time, in order to ensure slow flooding and dehydration of the membrane [22]. EIS tests in flooded condition were carried out, with a relative humidity of 50% on the cathode side and 70% on the anode side, and the model parameters were adjusted according to the test results. The same procedure was performed with a relative humidity of 15% on the cathode side and 10% on the anode side, in order to carry out tests in dry conditions. The adjusted models for each of the cases presented in [22], are shown in Fig. 6. The higher the name of the experiment (Exp1, Exp3, ... Exp12) the longer the testing period of the FC under specific conditions. The flooding process

is characterized by a growth in the real impedance part at low frequencies, whilst the drying process is characterized by the move of the EIS curve to the right of the real axis and by the expansion of the low-frequency loop to a size comparable to the high-frequency one. During the flooding process the parameters R_p and R_d increased with each experiment, whilst in the other process R_m was the parameter that grew. Figure 6(c) demonstrates the possibility of characterizing the hydration state of the membrane using EIS within the range of 0.1 Hz to 1 kHz. The same results and conclusions were also obtained in [6, 7, 23]. The main drawback of this method was that the system used is unsuitable for on-board integration. An embedded frequency response analyzer for FCs was presented in [24]. It was implemented with a low-cost digital signal processor of small size and low-power consumption, which can be embedded into the FC controller or power-conditioning unit. The main advantage of this system is the ability of automatically measuring the frequency response of the FC at different operating points, even when the FC is operating with a load. This embedded instrument can be used as the FC state of hydration monitoring device, as it estimates all the circuitual parameters that were described in [22], during FC operation with any load.

A different analytic electrical model of a FC was proposed in [25] and is shown in Fig. 7. Both electrodes (anode and cathode) are presented with Randles models and are connected in series with the internal resistance R_m linked to the membrane [26, 27]. In Fig. 7, C_{dl} is the double-layer capacitance expressed in [F]. The PEMFC humidification scheme presented in Fig. 7 was analyzed in [25]. At high frequencies the model can be reduced to the membrane resistance R_m . Therefore, this resistance can be deduced at high frequency, dividing the voltage and the current variation in the FC as [25]

$$R_m = \left(\frac{\Delta V_{FC}}{\Delta I_{FC}} \right). \quad (4)$$

Since in most applications the voltage of the Fc is low, it is necessary to use dc-dc converters in order to increase the FC output voltage. The advantage of the work presented in [25] is that it doesn't require any additional equipment to generate high-frequency current ripple, whilst the boost converter generates its natural current ripple of 25 kHz, which corresponds to the switching frequency. The main drawback of this work is that the high frequency can only indicate whether the membrane is dry, but not if it is flooded, whilst in this case the FC has similar resistance to that during normal operation, as shown in Fig. 6(c). A similar conclusion is presented in [28], where it was determined that an increase in pressure drop, particularly on the cathode side, is considered to be a reliable indicator of

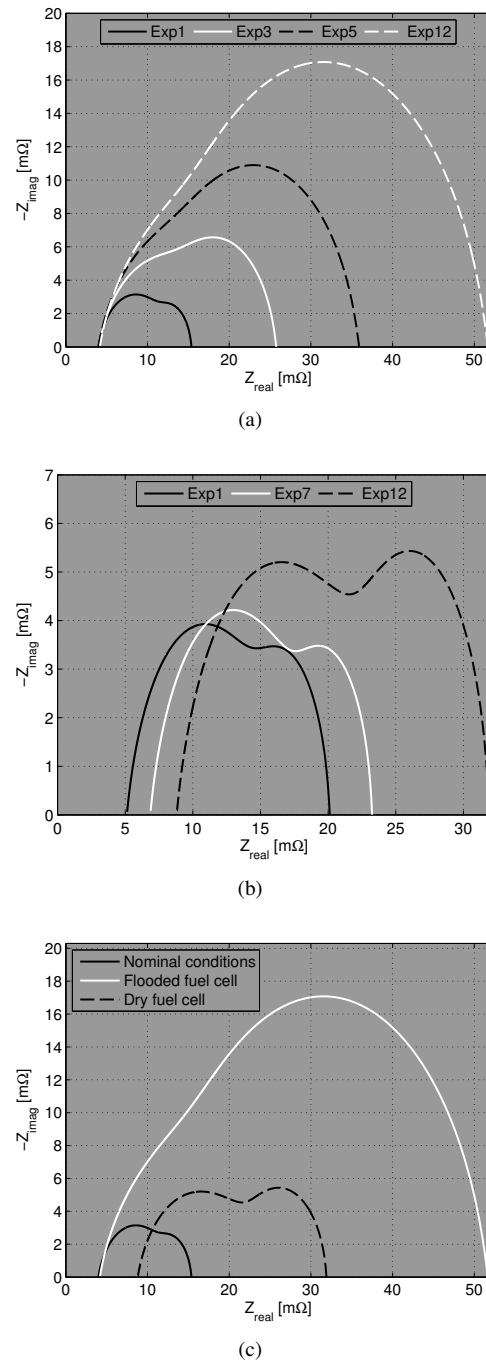

Fig. 6. Nyquist plot of the fuel cell impedance spectrum in: (a) Flooded conditions, (b) Dry conditions, (c) Different conditions

PEMFC flooding. On the other hand, an increase in cell resistance is a reliable indicator of FC drying. The problem of installing pressure sensors on the cathode side of the FC has already been described above.

The main strategies for mitigating water flooding de-

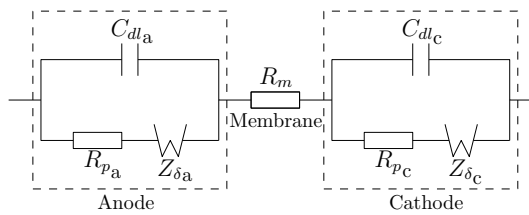

Fig. 7. Complete equivalent electrical circuit schematic, as used in [25]

scribed in the literature correspond to those strategies adopted by FC manufacturers [20]. One is the previously explained flow field design [29–32]. Another strategy is the anode water removal that is based on a decrease in the anode pressure by purging. In this way an increase in the ability of the stream to carry water vapor is achieved and thus a substantial portion of water could be removed at the cathode [33, 34]. Other strategies to mitigate flooding known as the manipulation of the operating conditions of the FC, such as increasing the cathode gas flow-rate [33, 35, 36], flushing the cathode periodically with a high air flow-rate for a short time [36, 37], and shaking or orienting the FC during its operation [38], can produce significant parasitic losses or increase the FC system's complexity [20]. A simpler approach for mitigating water flooding is through designing the membrane electrode assembly's components to function in the presence of liquid water [20, 39].

All the above-presented strategies for mitigating water flooding are outside the scope of power electronics. The only study where a power electronic device is used as an element for improving the performance of the FC under a bad water management condition is [40]. This work deals with an EIS study of a single cell under different humidity conditions similar to [22], but using an equivalent circuit similar to [25]. The most important part of this work is the mitigation of problems caused by the flooding or drying of the FC by selecting the most suitable operating point with a boost—cascade—buck converter connected to it. The authors claim that a low-current operation has the advantage of mitigating the flooding fault. The drying fault is, on the other hand, mitigated by operating at high current densities, as operating at this point results in more water production at the cathode side, which thus increases the amount of liquid water in the membrane. In future work, embedded frequency response analyzers can be used, like the one presented in [24] for EIS study. It is possible to monitor the water management within the FC, using this system in conjunction with an equivalent circuit model, as used in [22]. In this way the flooded, dry or normal operation can be identified. The current control of the converter proposed in [14] could be used for the mitigation of bad water management. Finally, it is considered that water management

is a relatively new area of research in power electronics, and has a great future.

4 REACTANT GAS STARVATION

Fuel or oxidant starvation is a complicated phenomenon that refers to the operation of fuel cells under sub-stoichiometric reaction conditions, and is one of the potential causes of fuel cell failure [8, 41]. In the case of fuel starvation, the amount of hydrogen is insufficient for the normal oxidation process that maintains the current. Consequently the anode potential rises to the level required for oxidizing the water. This results in the evolution of oxygen and protons at the anode, as in [8, 41, 42]

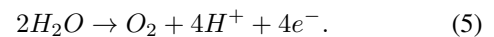

The chemical reaction on the cathode side is still present, as described with (2). The only difference is that the protons and electrons of the hydrogen come from water oxidation at the anode and not from the normal supply of hydrogen. The presence of oxygen on the anode due to reaction (5) has been proved using gas chromatographic analysis [42]. On the other hand, the oxygen starvation phenomenon occurs when the amount of oxygen supplied to the fuel cell is insufficient for reacting in accordance with the demand of the stack current. The described chemical reaction at the cathode can be derived from (2), with absence of oxygen as follows [8, 41, 42]

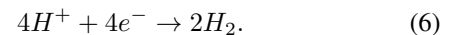

As described by (5) and (6), reactant gas starvation can result in the generation of hydrogen in the cathode or oxygen in the anode. Thus, a negative potential difference appears between the anode and the cathode [8, 36]. This so-called "cell reversal" accelerates the catalyst loss and the carbon-support corrosion [8, 41, 43, 44]. Gas starvation can be caused by several factors, such as poor water management, poor gas feeding management, and an imperfect stack and cell design, as well as poor stack assembly [8]. One solution to this problem is to modify the flow of hydrogen and oxygen in order to avoid reactant gas starvation at the maximum operating current of the FC [4]. However, this solution is inefficient because the air pump can consume up to 30% of the power generated by the FC [45] and an additional increase in hydrogen consumption would make the FC operation even more costly.

The output characteristics of a PEMFC are limited by mechanical devices that are used to maintain the air-flow within the cathode using a compressor or a blower, hydrogen-flow in the anode through an adjustable valve command, temperature control using a cooling-fan, and the

humidity of the air in the cell using a humidity-exchanger, as illustrated in Fig. 2. As the hydrogen, usually stored in a pressurized tank is fed through a fast opening valve, air-flow can be considered as the main control variable of a PEMFC [46, 47]. For this reason, major efforts within scientific literature have focused on preventing, modeling, and studying the oxygen starvation phenomenon. As a consequence of limitations on FC dynamics by mechanical devices, mainly the compressor, a load transient will cause a high voltage drop after a short time, well-known as the oxygen starvation phenomena [48]. This operational condition is evidently harmful for the FC and for this reason it is considered as slow dynamic-response equipment with respect to the transient load requirements. Therefore, batteries, ultracapacitors or other auxiliary power sources are needed to support the operation of the FC, in order to ensure a fast response to any load power transient. The systems formed by a FC and an other auxiliary power source, known as FC hybrid systems, have been extensively researched over recent years [49–52]. These hybrid systems can limit the slope of the current or power generated by the FC, with the use of current-controlled dc-dc converters. In this way the reactant gas starvation can be avoided and the system can operate with higher efficiency [53–56].

Models for analyzing those air-flow controllers that protect the FC from oxygen starvation during load transients, estimate the oxygen excess ratio and allow for studying the interactions between different elements connected to the FC, like dc-dc and dc-ac converters, can be found in [2, 3, 24, 57–62]. As mentioned above, oxygen starvation is a complex phenomenon that reduces the lifetime of a FC. This phenomenon entails a rapid decrease in cell-voltage, which can in several cases cause a hot spot, or even a burn-through on the surface of the membrane [3]. In the literature it is possible to find several studies about the oxygen starvation phenomenon, which has become another important area of research regarding FCs. In [56] controlling the FC air-pump voltage and regulating the FC-current through a dc-dc switching converter provides FC protection against the oxygen starvation phenomenon. For studying the behavior of a PEMFC under different air stoichiometric conditions, a test station for FCs was built in [63] and equipped with versatile control systems that control the fuel-flow, the air-flow, and the temperature. The design of a high-speed three-phase switch reluctance machine (SRM), as presented in [63], is needed for driving a compressor in regard to the air management of an automotive application FC, since this kind of compressor-motor is widely-used in high-speed applications. The two models of predictive control loops proposed and compared in [45] were designed with the aim of satisfying the oxygen starvation avoidance criterion, and the maximum efficiency criterion in the FC. A very similar goal is addressed in [64], which analyzes

the performance limitations and trade-offs associated with compressor-driven air-supply and discusses different feed-forward and feed-back architecture controllers for avoiding oxygen starvation during load changes. A PEMFC dynamic electrical-circuit model that can estimate the oxygen excess ratio is presented in [59], and its model is used in [58] to implement a real-time simulation system. In [65] a simplified model of the permanent-magnet synchronous motor is used to feed the FC with air. This control ensures less excursions away from the motor-equilibrium operation point, thus reducing the risk of oxygen starvation, and reacts quickly to load changes.

5 CURRENT RIPPLE

As described in previous sections, PEMFC generates unregulated dc energy. The level of output dc voltage depends on the FC power rating or, more precisely, on the number of cells connected in the series. The majority of commercially available FCs generate output voltage within the range of 25–50 V [66]. A power conditioning unit (PCU) is required in order to adapt the generated voltage to the demands of the load. According with the load requirements, PCUs can be divided into two groups: 1) PCUs for dc applications and 2) PCUs for ac applications. The first group is represented by dc-dc converters, whilst the second is, in most cases, represented by the combination of a dc-dc converter in series with a dc-ac inverter. When designing a PCU, the criteria have to be met relating to conversion efficiency, production costs, electrical isolation, current ripple and reliability [66].

A topic that has been a subject of extensive research over recent years and is of great importance for the performance and durability of a FC, is the FC current ripple. According to [67], there are low-frequency as well as high-frequency ripple components in FC current. Low-frequency ripple appears with PCUs for ac applications, where an inverter load is applied to a FC. It is generated due to the rectification effect through the inverter switches and, therefore, it appears as pulsating current with double frequency (e.g., 100 Hz) for fuel cell systems powering single-phase loads (e.g., 50 Hz) [68]. On the other hand, high-frequency ripple is related to a dc-dc converter switching frequency and the carrier frequency of a pulse-width modulated output stage [67]. It appears with both aforementioned groups of PCUs.

It is known that reactant utilization impacts the mechanical nature of a FC. Therefore, it is assumed that those varying reactant conditions caused by the current ripple, govern (at least in part) the lifetime of the cells [67]. Both parameters of ripple current, its magnitude and its frequency, are important. On the basis of [6, 67, 69] it can be concluded that the high-frequency ripple insignificantly

affects the performance, behavior and lifetime of a FC, except at very high ripple factors. In contrast, it has been reported that low-frequency ripple components (<400 Hz) have several negative effects, such as: reducing the FC lifetime and efficiency [70–74], increasing fuel consumption [72–74], and mechanical stress of the membrane [73], making cathode surface responses slower, leading to the occurrence of gas starvation and incurring nuisance tripping, like an overload situation [72].

For the aforementioned reasons and the fact that additional power losses increase with increasing the magnitude of the current ripple [75], FC current ripple reduction has become one of the more important tasks when designing a PCU. The values to which the current ripple should be reduced vary considerably from FC producers to experts dealing with this issue. Ballard Power Systems, for example, has specified that the maximum value of 100/120 Hz component of current ripple for its 1.2 kW Nexa™ PEM fuel cell is 24.7% RMS (or 35% peak-to-peak) [76]. According to experimental tests carried out on the aforementioned FC system [70], limiting the low-frequency current ripple to between 30% and 40%, results in less than a 0.5–1.5% reduction in FC output power. More stringent limitations for current ripple have been proposed even though this may be acceptable in many cases. In [67] it is suggested that, in order to achieve negligible impact regarding the performance and lifetime of a PEMFC, low-frequency ripple should be controlled to less than 4%. Alternatively, [77] specifies allowable ripple factors for the entire harmonic spectrum of the FC current from 10% to 100% load. It is suggested that fundamental frequency current ripple is limited to below 10% of its rated value, low-frequency current ripple to below 15% and high-frequency current ripple (>10 kHz) to below 60%.

Since high-frequency current ripple with a magnitude above 60% of the fundamental frequency current component could be harmful to the FC, it is necessary to keep it as low as possible. It is possible to reduce it by the use of passive compensation approaches, like connecting a low-pass filter between the FC and PCU or applying a zero ripple filter [78]. Bulky passive filter components must be used in order to achieve a sufficient degree of high-frequency ripple suppression in high-power applications. The latter, not only increase the size of the PCU, but also its production costs and power losses.

Another FC current ripple reduction approach is based on connecting dc-dc converters in parallel with an interleaving technique [79–81], as shown in Fig. 8. It is considered an active ripple reduction method. Its basic idea is the operation of modules at the same switching frequency, whilst their switching waveforms are phase-shifted over a switching period with respect to one another by T_s/N , T_s being the switching period and N the number of converters

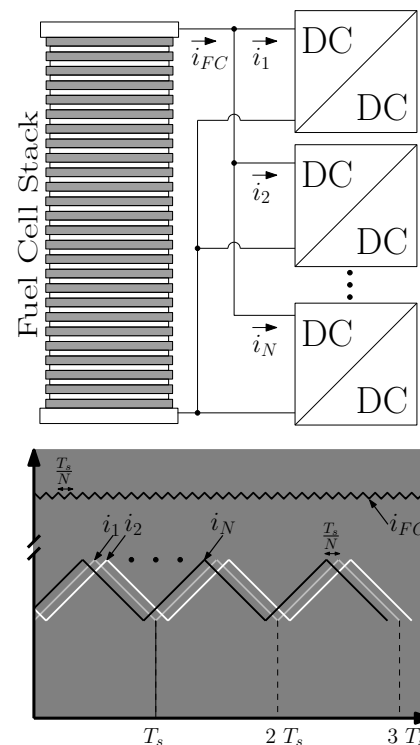

Fig. 8. Parallel connection of dc-dc converter with interleaving technique

in parallel. This arrangement of switching waveforms and consequently the way individual modules are clocked, lowers the net ripple magnitude. The input current is equally shared amongst the converters, by paralleling them. Hence, any current stress on the semiconductor devices on the input side is reduced and smaller passive components can be used [81]. This results in an increased efficiency, as well as reliability, of the PCU and makes the approach suitable for use in high-power applications [80]. The effectiveness of the interleaving technique was proved by experimental testing using 2- and 4-module interleaved converter on a 1.2 kW Nexa™ PEM fuel cell in [80]. The test results showed that the FC current ripple was $1/N$ the individual inductor ripple and in the case of using the 4-module interleaved converter, the high-frequency ripple was suppressed to almost zero at the FC current reference of 30 A.

As mentioned in the introductory part of this section, low-frequency current ripple can cause, in contrast to high-frequency ripple, severe damage to the FC at much lower magnitudes. For this reason substantial research has been done with the aim of reducing it. As a result, there are many passive as well as active ripple reduction methods proposed in the literature.

Using the classical passive current ripple compensation approach, a bulky energy storage device, like a capaci-

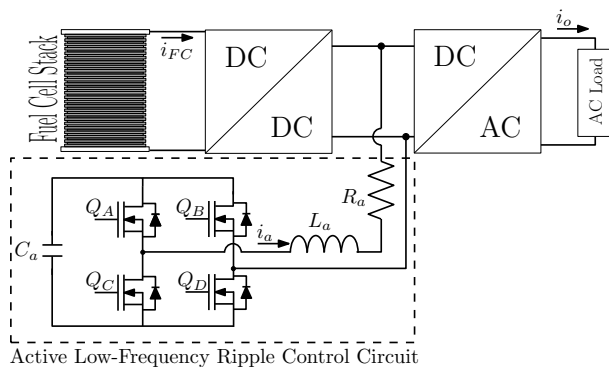

Fig. 9. Conventional double-stage FC PCU with active low-frequency ripple-control circuit, as proposed in [84]

tor [82] or a series LC circuit [83], is connected to the low- or high-voltage side of the dc-dc converter. Although a considerable reduction in low-frequency current ripple can be achieved this way, the increased size of the converter and more power dissipation as a consequence of additional passive components within the circuit, represent major drawbacks for passive ripple reduction approaches.

It is for these reasons that active ripple reduction methods have become prevalent amongst researchers lately. According to [84], active ripple reduction approaches are classified into two main categories. One is the power-conditioner self-controlling method [73, 74, 85, 86] and the other is the current-ripple injection method [71, 84, 87–89]. The latter is distinguished by its mobility over various applications, as it can be used with many different converter topologies. It works on the principle of directly injecting compensation ripple current into a coupling point at either high-voltage or low-voltage bus of any PCU. The ripple compensation current is generated by additional back-up units, which use capacitors, supercapacitors or batteries as energy storage devices.

Figure 9 presents the active low-frequency ripple-control circuit that is proposed in [84] and intended for use in double-stage PCUs. It is in fact a full-bridge inverter, with a filter inductor L_a and an energy storage capacitor C_a , connected to the high-voltage side of the dc-dc converter. Switches (Q_A, Q_B, Q_C, Q_D) of the ripple compensation unit are triggered according to the reference-current command of the output filter inductor L_a , in order to inject adequate compensation current i_a . Experimental results have shown that this approach is efficient for low-frequency ripple reduction as the 120 Hz component can be reduced by up to 90%.

Another promising topology that is based on the current-ripple injection method is proposed in [87, 88] and suitable for use in single-stage PCUs. It incorporates a back-up energy storage unit that consists of a current

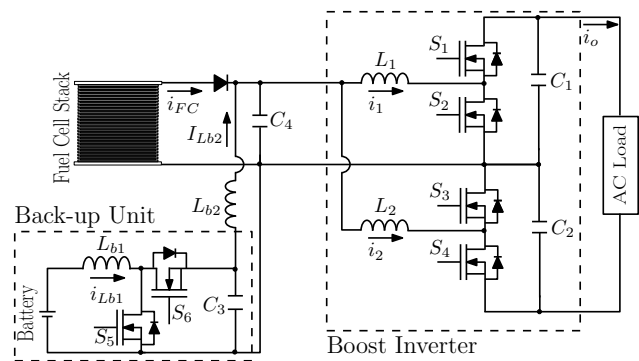

Fig. 10. FC energy system based on a single-stage boost inverter with energy storage back-up unit, as proposed in [87, 88]

mode controlled bi-directional converter, a battery as the energy storage medium and an LC passive filter. Apart from supporting the slow dynamics of the FC during load transients, the back-up unit has an additional function of protecting the FC. The current control compensates low-frequency current ripple, whilst the LC filter eliminates the switching-frequency ripple components. The structure of the described system is shown in Fig. 10.

Mazumder *et al.* [71] have proposed a multi-stage PCU topology that can achieve the mitigation of both low- and high-frequency current ripple. The PCU consists of a zero-ripple boost converter (ZRBC) followed by a soft-switched multi-level high-frequency inverter and single-phase cycloconverter, as shown in Fig. 11. The mechanism of ripple mitigation is based on a zero-ripple filter (ZRF) that consists of a coupled inductor-based filter for minimizing the high-frequency current ripple and a half-bridge active power filter (APF) for mitigating the low-frequency ripple. Experimental results have shown that the high-frequency ripple is reduced to 20% and low-frequency ripple to 15% of the maximum current ripple values, measured without the use of the ripple mitigation mechanism.

A special active ripple reduction technique was presented in [86]. It is based on a novel circuit topology that includes an active filter function without any extra switching devices. The active filter function is achieved by connecting the energy buffer capacitor C_f to the center tap of the transformer, which is then controlled by the zero switching vector of the first-stage inverter. The proposed circuit is presented in Fig. 12 and consists of a first-stage inverter for the medium frequency link, a transformer, a diode rectifier, and a grid interconnection inverter. The first-stage inverter has to perform the roles of both a dc-dc converter and an active filter. These roles are achieved by controlling the common-mode and differential-mode inverter voltages. Whilst the main power flow is controlled

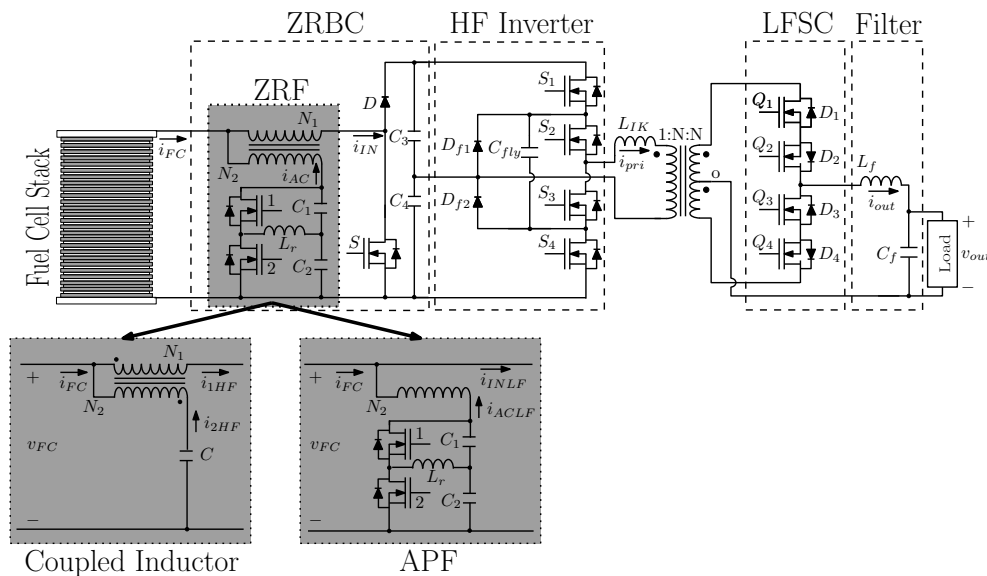

Fig. 11. Schematic of the PCU proposed in [71]

by the differential-mode voltage, the ripple current is suppressed by the common-mode voltage. Experimental tests have proven the effectiveness of the active filter function, as the low-frequency ripple was reduced to 20% of the one measured in the test without an active filter.

The main drawback of the current-ripple injection method is the increase in size and production costs of the PCU, as an additional back-up energy storage unit has to be designed, built and applied to the basic converter structure. In contrast, power-conditioner self-controlling approaches do not require any additional converters or energy storage components. Hence the overall system's size and costs are not increased.

Self-controlling ripple reduction methods for conventional double-stage FC inverters are presented in [73] and [74]. Both of them are fully implemented with software. Liu and Lai [74] proposed a control strategy that is based on adding a current control loop into the existing voltage control system. With a proper selection of control bandwidth for both the inner and outer control loops, it is possible to significantly reduce the current ripple whilst maintaining a stable dc bus voltage. Experimental tests have shown a reduction in low-frequency current ripple from 12.5% to less than 2% with the use of the proposed control system. An alternative low-frequency current ripple reduction control strategy for conventional double-stage FC inverters was proposed in [73]. This solution is based on a single sensorless current feedback loop that controls the dc-dc converter. Simulation tests showed promising results, as the 100 Hz current ripple component was reduced from 10.2% to 0.027%.

Kwon et al. [85] presented a double stage PCU that consists of a current-fed resonant push-pull converter and a full-bridge inverter. This system is distinguished by an extremely low switching-frequency current ripple at a duty ratio of around 0.5. The proposed low-frequency current ripple reduction technique is based on the inclusion of a ripple cancelation duty ratio into the control structure. Experimental tests carried out with a 1.5 kW prototype at full load and an average FC current of 33 A, have shown a reduction in low-frequency current ripple from 18% to 1.8% with the use of described ripple reduction method.

As most of the research in the field of FC current ripple reduction is already directed towards active reduction methods, it is expected that this trend will continue. Self controlling techniques have shown a lot of potential, as they can achieve considerable degrees of low-frequency ripple reduction without the use of any additional components that would negatively affect the size, costs and efficiency of the PCU. What is especially interesting for implementing the above-mentioned techniques are the single-stage inverter topologies, like buck-boost inverter [87] boost inverter [88], and Z-source inverter [90]. Their major drawback is the input current ripple and hence they are infrequently used in distributed energy systems, like fuel cell and photovoltaic applications. On the other hand, the low number of passive and active components, the simple circuit, single stage conversion and consequently small size, low production costs and high efficiency, make them very interesting for use in such systems. As every interference in the switching strategy of a single-stage inverter is reflected in the output voltage and current, the implementation of a self-controlled ripple reduction technique

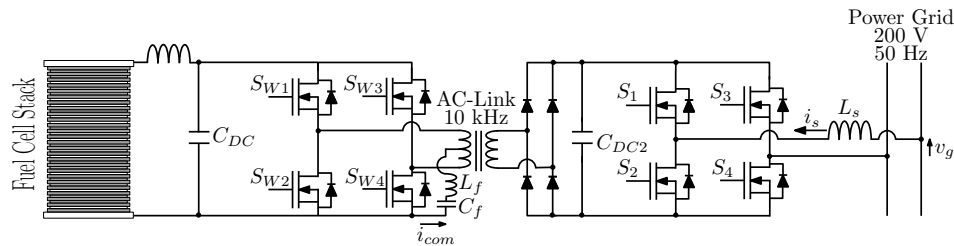

Fig. 12. Single-phase isolated converter with an active filter function, as proposed in [86]

is especially complex. Therefore it represents a real challenge for the future. With the aim of reducing the costs, increasing the efficiency and extending the lifetime of FC applications, a lot of attention needs to be given to developing and designing of novel low input current ripple converters, as well. Therefore it is expected, that future work will include the design of a low input current ripple inverter, composed of two identical coupled-inductor bidirectional buck-boost converters in differential/subtracting-stacking configuration [91, 92]. Low input current ripple of the described converter structure is achieved by selecting an appropriate turns ratio of the coupled inductors, as proposed in [93].

6 CONCLUSION

This article gives a comprehensive review of the main advances in power electronics that have the ability to improve efficiency and durability, as well as ensure safe and reliable operation of PEMFCs. On the basis of an extensive literature review dealing with the main phenomena that affect the lifetime and the long-term performance of PEMFCs, power electronics solutions have been discussed that could mitigate these problems. The major issues that affect the durability and efficiency of the FC stack, for which solutions within the scope of power electronics are available, are poor water management, reactant gas starvation, and current ripple. Understanding these issues and the way to solve them is very important for researchers working on the design of those power-electronic devices used in PEMFC energy systems. Power electronics plays a crucial role in the positioning of fuel cells as popular energy sources for mobile and stationary applications. The authors believe that this article will be helpful for those power electronics researchers and engineers interested in new design criteria or looking for future research areas.

ACKNOWLEDGEMENTS

This work was supported by the Spanish Ministerio de Ciencia e Innovación under the projects CSD2009-00046, TEC2009-13172, DPI2010-16084 and the FPU scholarship AP2008-03305.

REFERENCES

- [1] J. Larminie and A. Dicks, *Fuel Cell Systems Explained*, 2nd ed. Wiley, 2003.
- [2] J. Correa, F. Farret, L. Canha, and M. Simoes, "An electrochemical based fuel cell model suitable for electrical engineering automation approach," *IEEE Transactions on Industrial Electronics*, vol. 51, no. 5, pp. 1103 – 1112, Oct. 2004.
- [3] J. Pukrushpan, A. Stefanopoulou, and H. Peng, "Control of fuel cell breathing," *IEEE Control Systems Magazine*, vol. 24, no. 2, pp. 30 – 46, Apr. 2004.
- [4] P. Thounthong and P. Sethakul, "Analysis of a fuel starvation phenomenon of a pem fuel cell," in *Power Conversion Conference - Nagoya 2007, PCC '07*, Apr. 2007, pp. 731–738.
- [5] D. Nelson, M. Nehrir, and V. Gerez, "Economic evaluation of grid-connected fuel-cell systems," *IEEE Transactions on Energy Conversion*, vol. 20, no. 2, pp. 452 – 458, Jun. 2005.
- [6] B. Wahdame, D. Candusso, X. Francois, F. Harel, M.-C. Pera, D. Hissel, and J. Kauffmann, "Analysis of a fuel cell durability test based on design of experiment approach," *IEEE Transactions on Energy Conversion*, vol. 23, no. 4, pp. 1093 – 1104, Dec. 2008.
- [7] J.-M. L. Canut, R. M. Abouatallah, and D. A. Harrington, "Detection of membrane drying, fuel cell flooding, and anode catalyst poisoning on PEMFC stacks by electrochemical impedance spectroscopy," *Journal of The Electrochemical Society*, vol. 153, no. 5, pp. A857–A864, 2006.
- [8] W. Schmittinger and A. Vahidi, "A review of the main parameters influencing long-term performance and durability of pem fuel cells," *Journal of Power Sources*, vol. 180, no. 1, pp. 1 – 14, May 2008.
- [9] G. Hinds, "Performance and durability of PEM fuel cells: A review," NPL Report DEPC-MPE 002, Tech. Rep., Sep. 2004.
- [10] Y. Sone, P. Ekdunge, and D. Simonsson, "Proton conductivity of nafion 117 as measured by a four-electrode AC impedance method," *Journal of The Electrochemical Society*, vol. 143, no. 4, pp. 1254–1259, Apr. 1996.
- [11] T. V. Nguyen and R. E. White, "A water and heat management model for proton-exchange-membrane fuel cells," *Journal of The Electrochemical Society*, vol. 140, no. 8, pp. 2178–2186, Aug. 1993.

- [12] Y. Wang and C.-Y. Wang, "Dynamics of polymer electrolyte fuel cells undergoing load changes," *Electrochimica Acta*, vol. 51, no. 19, pp. 3924 – 3933, May 2006.
- [13] L. Palma and P. Enjeti, "A modular fuel cell, modular DC-DC converter concept for high performance and enhanced reliability," *IEEE Transactions on Power Electronics*, vol. 24, no. 6, pp. 1437 – 1443, Jun. 2009.
- [14] E. Frappe, A. De Bernardinis, G. Coquery, O. Bethoux, and C. Marchand, "A soft-switching four-port dc-dc converter for segmented PEM fuel cell power management in vehicle application," in *Vehicle Power and Propulsion Conference (VPPC), 2011 IEEE*, Sep. 2011, pp. 1 – 6.
- [15] Y. D. K. A. F. Broque, J. Ramousse and P. Adzaka, "Sensitivity study of flooding and drying issues to the operating conditions in PEM fuel cells," *International Journal of Energy and Environment (IJEE)*, vol. 1, no. 1, pp. 1–20, Sep. 2010.
- [16] J. Park and X. Li, "Effect of flow and temperature distribution on the performance of a PEM fuel cell stack," *Journal of Power Sources*, vol. 162, no. 1, pp. 444– 459, Sep. 2006.
- [17] T. V. Nguyen, "A gas distributor design for proton exchange membrane fuel cells," *Journal of The Electrochemical Society*, vol. 143, no. 5, pp. L103–L105, May 1996.
- [18] D. L. W. III, J. S. Yi, and T. V. Nguyen, "Effect of direct liquid water injection and interdigitated flow field on the performance of proton exchange membrane fuel cells," *Electrochimica Acta*, vol. 43, no. 24, pp. 3795 – 3809, 1998.
- [19] L. Wang and H. Liu, "Performance studies of PEM fuel cells with interdigitated flow fields," *Journal of Power Sources*, vol. 134, no. 2, pp. 185 – 196, 2004.
- [20] H. Li, Y. Tang, Z. Wang, Z. Shi, S. Wu, D. Song, J. Zhang, K. Fatih, J. Zhang, H. Wang, Z. Liu, R. Abouatallah, and A. Mazza, "A review of water flooding issues in the proton exchange membrane fuel cell," *Journal of Power Sources*, vol. 178, no. 1, pp. 103 – 117, 2008.
- [21] W. He, G. Lin, and T. V. Nguyen, "Diagnostic tool to detect electrode flooding in proton-exchange-membrane fuel cells," *AIChE Journal*, vol. 49, no. 12, pp. 3221–3228, 2003.
- [22] N. Fouquet, C. Doulet, C. Nouillant, G. Dauphin-Tanguy, and B. Ould-Bouamama, "Model based PEM fuel cell state-of-health monitoring via AC impedance measurements," *Journal of Power Sources*, vol. 159, no. 2, pp. 905 – 913, 2006.
- [23] H. Sian, "The root causes of underperformance," *The Fuel Cell Review*, vol. 2, no. 1, pp. 32 – 34, Feb.-Mar. 2005.
- [24] M. Ordonez, M. Sonnaillon, J. Quaiocoe, and M. Iqbal, "An embedded frequency response analyzer for fuel cell monitoring and characterization," *IEEE Transactions on Industrial Electronics*, vol. 57, no. 6, pp. 1925 – 1934, Jun. 2010.
- [25] M. Hinaje, I. Sadli, J. Martin, P. Thounthong, S. Rael, and B. Davat, "Online humidification diagnosis of a pemfc using a static dc-dc converter," *International Journal of Hydrogen Energy*, vol. 34, no. 6, pp. 2718 – 2723, 2009.
- [26] M. U. Iftikhar, D. Riu, F. Druart, S. Rosini, Y. Bultel, and N. Retiore, "Dynamic modeling of proton exchange membrane fuel cell using non-integer derivatives," *Journal of Power Sources*, vol. 160, no. 2, pp. 1170 – 1182, 2006.
- [27] M. Rubio, A. Urquia, and S. Dormido, "Diagnosis of PEM fuel cells through current interruption," *Journal of Power Sources*, vol. 171, no. 2, pp. 670 – 677, 2007.
- [28] F. Barbir, H. Gorgun, and X. Wang, "Relationship between pressure drop and cell resistance as a diagnostic tool for pem fuel cells," *Journal of Power Sources*, vol. 141, no. 1, pp. 96 – 101, 2005.
- [29] X. Li, I. Sabir, and J. Park, "A flow channel design procedure for PEM fuel cells with effective water removal," *Journal of Power Sources*, vol. 163, no. 2, pp. 933 – 942, 2007.
- [30] C. Xu and T. Zhao, "A new flow field design for polymer electrolyte based fuel cells," *Electrochemistry Communications*, vol. 9, no. 3, pp. 497 – 503, 2007.
- [31] A. Turhan, K. Heller, J. Brenizer, and M. Mench, "Passive control of liquid water storage and distribution in a pemfc through flow-field design," *Journal of Power Sources*, vol. 180, no. 2, pp. 773 – 783, 2008.
- [32] P. Suresh, S. Jayanti, A. Deshpande, and P. Haridoss, "An improved serpentine flow field with enhanced cross-flow for fuel cell applications," *International Journal of Hydrogen Energy*, vol. 36, no. 10, pp. 6067 – 6072, 2011.
- [33] H. Voss, D. Wilkinson, P. Pickup, M. Johnson, and V. Batura, "Anode water removal a water management and diagnostic technique for solid polymer fuel cells," *Electrochimica Acta*, vol. 40, no. 3, pp. 321 – 328, 1995.
- [34] D. Wilkinson, H. Voss, and K. Prater, "Water management and stack design for solid polymer fuel cells," *Journal of Power Sources*, vol. 49, no. 1 and 3, pp. 117 – 127, 1994.
- [35] K. Tuber, D. Pocza, and C. Hebling, "Visualization of water buildup in the cathode of a transparent PEM fuel cell," *Journal of Power Sources*, vol. 124, no. 2, pp. 403 – 414, 2003.
- [36] T. V. Nguyen and M. W. Knobbe, "A liquid water management strategy for PEM fuel cell stacks," *Journal of Power Sources*, vol. 114, no. 1, pp. 70 – 79, 2003.
- [37] M. Knobbe, W. He, P. Chong, and T. Nguyen, "Active gas management for PEM fuel cell stacks," *Journal of Power Sources*, vol. 138, no. 1 and 2, pp. 94 – 100, 2004.
- [38] A. Mughal and X. Li, "Experimental diagnostics of PEM fuel cells," *International Journal of Environmental Studies*, vol. 63, no. 4, pp. 377–389, 2006.
- [39] T. V. Nguyen, D. Natarajan, and R. Jain, "Optimized catalyst layer structure for PEM fuel cells," *ECS Transactions*, vol. 1, no. 6, pp. 501–508, 2006.
- [40] A. Gebregergis, P. Pillay, and R. Rengaswamy, "Pemfc fault diagnosis, modeling, and mitigation," *IEEE Transactions on Industry Applications*, vol. 46, no. 1, pp. 295 – 303, Jan.-Feb. 2010.

- [41] Z. Liu, L. Yang, Z. Mao, W. Zhuge, Y. Zhang, and L. Wang, "Behavior of PEMFC in starvation," *Journal of Power Sources*, vol. 157, no. 1, pp. 166 – 176, 2006.
- [42] S. D. Knights, K. M. Colbow, J. St-Pierre, and D. P. Wilkinson, "Aging mechanisms and lifetime of PEFC and DMFC," *Journal of Power Sources*, vol. 127, no. 1 and 2, pp. 127 – 134, 2004.
- [43] A. Taniguchi, T. Akita, K. Yasuda, and Y. Miyazaki, "Analysis of electrocatalyst degradation in PEMFC caused by cell reversal during fuel starvation," *Journal of Power Sources*, vol. 130, no. 1-2, pp. 42 – 49, 2004.
- [44] N. Y. Steiner, P. Mocoteguy, D. Candusso, and D. Hissel, "A review on polymer electrolyte membrane fuel cell catalyst degradation and starvation issues: Causes, consequences and diagnostic for mitigation," *Journal of Power Sources*, vol. 194, no. 1, pp. 130 – 145, 2009.
- [45] A. Arce, A. del Real, C. Bordons, and D. Ramirez, "Real-time implementation of a constrained MPC for efficient air-flow control in a PEM Fuel Cell," *IEEE Transactions on Industrial Electronics*, vol. 57, no. 6, pp. 1892 – 1905, Jun. 2010.
- [46] W. Garcia-Gabin, F. Dorado, and C. Bordons, "Real-time implementation of a sliding mode controller for air supply on a PEM fuel cell," *Journal of Process Control*, vol. 20, no. 3, pp. 325 – 336, 2010.
- [47] J. Gruber, C. Bordons, and A. Oliva, "Nonlinear MPC for the airflow in a PEM fuel cell using a Volterra series model," *Control Engineering Practice*, vol. 20, no. 2, pp. 205 – 217, 2012.
- [48] H. P. Jay T. Pukrushpan, Anna G. Stefanopoulou, *Control of fuel cell power systems: principles, modeling, analysis, and feedback design*, 1st ed. Springer, 2004.
- [49] F. Segura, J. Andujar, and E. Duran, "Analog current control techniques for power control in PEM fuel-cell hybrid systems: A critical review and a practical application," *IEEE Trans. Ind. Electron.*, vol. 58, no. 4, pp. 1171 – 1184, april 2011.
- [50] M. Vasallo, J. Andujar, C. Garcia, and J. Brey, "A methodology for sizing backup fuel-cell/battery hybrid power systems," *IEEE Transactions on Industrial Electronics*, vol. 57, no. 6, pp. 1964 – 1975, Jun. 2010.
- [51] A. Shahin, M. Hinaje, J.-P. Martin, S. Pierfederici, S. Rael, and B. Davat, "High voltage ratio DC-DC converter for fuel-cell applications," *IEEE Trans. Ind. Electron.*, vol. 57, no. 12, pp. 3944 – 3955, dec. 2010.
- [52] X. Zhu, X. Li, G. Shen, and D. Xu, "Design of the dynamic power compensation for PEMFC distributed power system," *IEEE Transactions on Industrial Electronics*, vol. 57, no. 6, pp. 1935 – 1944, Jun. 2010.
- [53] P. Rodatz, G. Paganelli, A. Sciarretta, and L. Guzzella, "Optimal power management of an experimental fuel cell supercapacitor-powered hybrid vehicle," *Control Engineering Practice*, vol. 13, no. 1, pp. 41 – 53, 2005.
- [54] P. Corbo, F. Corcione, F. Migliardini, and O. Veneri, "Experimental assessment of energy-management strategies in fuel-cell propulsion systems," *Journal of Power Sources*, vol. 157, no. 2, pp. 799 – 808, 2006.
- [55] P. Thounthong, S. Rael, B. Davat, and I. Sadli, "A control strategy of fuel cell/battery hybrid power source for electric vehicle applications," in *Power Electronics Specialists Conference, 2006. PESC '06. 37th IEEE*, Jun. 2006, pp. 1 – 7.
- [56] C. Ramos-Paja, C. Bordons, A. Romero, R. Giral, and L. Martinez-Salamero, "Minimum fuel consumption strategy for PEM fuel cells," *IEEE Transactions on Industrial Electronics*, vol. 56, no. 3, pp. 685 – 696, Mar. 2009.
- [57] X. Kong and A. Khambadkone, "Modeling of a PEM Fuel-Cell stack for dynamic and steady-state operation using ANN-based submodels," *IEEE Transactions on Industrial Electronics*, vol. 56, no. 12, pp. 4903 – 4914, Dec. 2009.
- [58] J.-H. Jung, S. Ahmed, and P. Enjeti, "PEM Fuel-Cell stack model development for real-time simulation applications," *IEEE Transactions on Industrial Electronics*, vol. 58, no. 9, pp. 4217 – 4231, Sept. 2011.
- [59] C. Ramos-Paja, R. Giral, L. Martinez-Salamero, J. Romano, A. Romero, and G. Spagnuolo, "A PEM fuel-cell model featuring oxygen-excess-ratio estimation and power-electronics interaction," *IEEE Transactions on Industrial Electronics*, vol. 57, no. 6, pp. 1914 – 1924, Jun. 2010.
- [60] L. Gauchia and J. Sanz, "A per-unit hardware-in-the-loop simulation of a fuel cell/battery hybrid energy system," *IEEE Transactions on Industrial Electronics*, vol. 57, no. 4, pp. 1186 – 1194, Apr. 2010.
- [61] A. Dhirde, N. Dale, H. Salehfar, M. Mann, and T. Han, "Equivalent electric circuit modeling and performance analysis of a pem fuel cell stack using impedance spectroscopy," *IEEE Transactions on Energy Conversion*, vol. 25, no. 3, pp. 778 – 786, Sep. 2010.
- [62] G. Fontes, C. Turpin, and S. Astier, "A large-signal and dynamic circuit model of a H_2/O_2 PEM Fuel Cell: Description, parameter identification, and exploitation," *IEEE Transactions on Industrial Electronics*, vol. 57, no. 6, pp. 1874 – 1881, Jun. 2010.
- [63] F. Marignetti, M. Minutillo, A. Perna, and E. Jannelli, "Assessment of Fuel Cell performance under different air stoichiometries and fuel composition," *IEEE Transactions on Industrial Electronics*, vol. 58, no. 6, pp. 2420 – 2426, Jun. 2011.
- [64] K.-W. Suh and A. Stefanopoulou, "Performance limitations of air flow control in power-autonomous fuel cell systems," *IEEE Transactions on Control Systems Technology*, vol. 15, no. 3, pp. 465 – 473, May 2007.
- [65] R. Talj, D. Hissel, R. Ortega, M. Becherif, and M. Hilairet, "Experimental validation of a pem fuel-cell reduced-order model and a moto-compressor higher order sliding-mode control," *IEEE Transactions on Industrial Electronics*, vol. 57, no. 6, pp. 1906 – 1913, Jun. 2010.

- [66] A. Kirubakaran, S. Jain, and R. Nema, "A review on fuel cell technologies and power electronic interface," *Renewable and Sustainable Energy Reviews*, vol. 13, no. 9, pp. 2430–2440, 2009.
- [67] R. S. Gemmen, "Analysis for the effect of inverter ripple current on fuel cell operating condition," *Journal of Fluids Engineering*, vol. 125, no. 3, pp. 576–585, 2003.
- [68] J.-S. Kim, H.-S. Kang, B.-K. Lee, and W.-Y. Lee, "Analysis of low frequency current ripples of fuel cell systems based on a residential loads modeling," in *International Conference on Electrical Machines and Systems, ICEMS 2007*, Oct. 2007, pp. 282–287.
- [69] G. Fontes, C. Turpin, R. Saissset, T. Meynard, and S. Astier, "Interactions between fuel cells and power converters influence of current harmonics on a fuel cell stack," in *IEEE 35th Annual Power Electronics Specialists Conference, 2004. PESC 04*, vol. 6, Jun. 2004, pp. 4729–4735.
- [70] W. Choi, J. Howze, and P. Enjeti, "Development of an equivalent circuit model of a fuel cell to evaluate the effects of inverter ripple current," *Journal of Power Sources*, vol. 158, no. 2, pp. 1324–1332, 2006.
- [71] S. Mazumder, R. Burra, and K. Acharya, "A ripple mitigating and energy efficient fuel cell power conditioning system," *IEEE Transactions on Power Electronics*, vol. 22, no. 4, pp. 1437–1452, Jul. 2007.
- [72] J.-S. Kim, B.-K. Lee, J. Hur, and D.-W. Yoo, "Analysis of low frequency current ripples in fuel cell electric vehicles considering driving conditions," in *IEEE Vehicle Power and Propulsion Conference, 2009. VPPC '09*, Sep. 2009, pp. 691–695.
- [73] A. Giustiniani, G. Petrone, G. Spagnuolo, and M. Vitelli, "Low-frequency current oscillations and maximum power point tracking in grid-connected fuel-cell-based systems," *IEEE Transactions on Industrial Electronics*, vol. 57, no. 6, pp. 2042–2053, Jun. 2010.
- [74] C. Liu and J.-S. Lai, "Low frequency current ripple reduction technique with active control in a fuel cell power system with inverter load," in *IEEE 36th Power Electronics Specialists Conference, 2005. PESC '05*, Jun. 2005, pp. 2905–2911.
- [75] L. Schindele, M. Braun, and H. Spath, "The influence of power electronic dynamics on pem fuel cell-system," in *European Conference on Power Electronics and Applications*, 2005, pp. 1–9.
- [76] *Nexa (310-0027) Power Module User Manual, MAN5100078*, Ballard Power Systems Inc., 2003.
- [77] E. . G. S. (Firm) and N. E. T. L. (U.S.), *Fuel cell handbook [electronic resource] / EG&G Technical Services, Inc*, 7th ed. U.S. Dept. of Energy, Office of Fossil Energy, National Energy Technology Laboratory, Morgantown, WV, 2004.
- [78] J. Kolar, H. Sree, N. Mohan, and F. Zach, "Novel aspects of an application of 'zero'-ripple techniques to basic converter topologies," in *28th Annual IEEE Power Electronics Specialists Conference, 1997. PESC '97 Record.*, vol. 1, Jun. 1997, pp. 796–803 Vol. 1.
- [79] D. Perreault and J. Kassakian, "Distributed interleaving of paralleled power converters," *IEEE Transactions on Circuits and Systems I: Fundamental Theory and Applications*, vol. 44, no. 8, pp. 728–734, Aug. 1997.
- [80] P. Thounthong, P. Sethakul, S. Rael, and B. Davat, "Fuel cell current ripple mitigation by interleaved technique for high power applications," in *IEEE Industry Applications Society Annual Meeting, 2009. IAS 2009*, Oct. 2009, pp. 1–8.
- [81] X. Kong and A. Khambadkone, "Analysis and implementation of a high efficiency, interleaved current-fed full bridge converter for fuel cell system," *IEEE Transactions on Power Electronics*, vol. 22, no. 2, pp. 543–550, Mar. 2007.
- [82] M. Schenck, J.-S. Lai, and K. Stanton, "Fuel cell and power conditioning system interactions," in *Twentieth Annual IEEE Applied Power Electronics Conference and Exposition, 2005. APEC 2005*, vol. 1, Mar. 2005, pp. 114–120 Vol. 1.
- [83] K. Fukushima, I. Norigoe, M. Shoyama, T. Ninomiya, Y. Harada, and K. Tsukakoshi, "Influence of small-series lc circuit on the input current-ripple for pulse-link dc-ac converter for fuel cells applications," in *13th European Conference on Power Electronics and Applications, 2009. EPE '09*, Sep. 2009, pp. 1–8.
- [84] R.-J. Wai and C.-Y. Lin, "Active low-frequency ripple control for clean-energy power-conditioning mechanism," *IEEE Transactions on Industrial Electronics*, vol. 57, no. 11, pp. 3780–3792, Nov. 2010.
- [85] J.-M. Kwon, E.-H. Kim, B.-H. Kwon, and K.-H. Nam, "High-efficiency fuel cell power conditioning system with input current ripple reduction," *IEEE Transactions on Industrial Electronics*, vol. 56, no. 3, pp. 826–834, Mar. 2009.
- [86] J.-I. Itoh and F. Hayashi, "Ripple current reduction of a fuel cell for a single-phase isolated converter using a dc active filter with a center tap," *IEEE Transactions on Power Electronics*, vol. 25, no. 3, pp. 550–556, Mar. 2010.
- [87] M. Jang, M. Ciobotaru, and V. Agelidis, "A single-stage fuel cell energy system based on a buck-boost inverter with a backup energy storage unit," *IEEE Transactions on Power Electronics*, vol. 27, no. 6, pp. 2825–2834, Jun. 2012.
- [88] M. Jang and V. Agelidis, "A minimum power-processing-stage fuel-cell energy system based on a boost-inverter with a bidirectional backup battery storage," *IEEE Transactions on Power Electronics*, vol. 26, no. 5, pp. 1568–1577, May 2011.
- [89] Y. R. Novaes and I. Barbi, "Low frequency ripple current elimination in fuel cell systems," in *Proc. Fuel Seminar Special Session Fuel Cell Power Conditioning*, Nov. 2003, pp. 21–27.
- [90] Y. Yu, Q. Zhang, X. Liu, and S. Cui, "Dc-link voltage ripple analysis and impedance network design of single-phase z-source inverter," in *Proceedings of the 2011-14th European Conference on Power Electronics and Applications (EPE 2011)*, Aug.-Sep. 2011, pp. 1–10.

- [91] R. Caceres, W. Garcia, and O. Camacho, "A buck-boost dc-ac converter: operation, analysis, and control," in *VI IEEE International Power Electronics Congress, 1998. CIEP 98*, Oct. 1998, pp. 126–131.
- [92] C. Restrepo, J. Calvente, A. Cid, A. El Aroudi, and R. Giral, "A non-inverting buck-boost DC-DC switching converter with high efficiency and wide bandwidth," *IEEE Transactions on Power Electronics*, vol. 26, no. 9, pp. 2490–2503, Sep. 2011.
- [93] M. Milanovic, F. Mihalic, K. Jezernik, and U. Milutinovic, "Single phase unity power factor correction circuits with coupled inductance," in *23rd Annual IEEE Power Electronics Specialists Conference, 1992. PESC '92 Record.*, Jun.-Jul. 1992, pp. 1077–1082 vol.2.



Carlos Restrepo graduated, with honors, as Ingeniero Electricista and Master en Ingeniería Eléctrica in 2006 and in 2007, respectively, from the Universidad Tecnológica de Pereira, Colombia. He obtained the Master en Ingeniería Electrónica from the Universitat Rovira i Virgili de Tarragona, Tarragona, Spain, in 2008. He is currently working toward the Ph.D. degree in the Departament d'Enginyeria Electrònica, Elèctrica i Automàtica, Escola Tècnica Superior d'Enginyeria, Universitat Rovira i Virgili de Tarragona. His main research interests include fuel cell modelling and power converters design.



Tine Konjedic received the B.Sc. degree in industrial engineering - option electrical engineering from the University of Maribor, Maribor, Slovenia, in 2009. Since 2010 he is employed as a researcher at the Faculty of Electrical Engineering and Computer Science, University of Maribor, Slovenia, where he is also working towards his Ph.D. degree. His main research interests are switching converters for small distributed power generation systems, in particular control and design of converters for photovoltaic and fuel cell applications.

applications.



Javier Calvente received the Ingeniero de Telecomunicación degree and the Ph.D. degree from the Universitat Politècnica de Catalunya (UPC), Barcelona, Spain, in 1994 and 2001, respectively. He was a visiting scholar with Alcatel Space Industries, Toulouse, France, in 1998. He is currently an Associate Professor with the Departament d'Enginyeria Electrònica, Elèctrica i Automàtica, Universitat Rovira i Virgili (URV), Tarragona, Spain, where he is working in the fields of power electronics and control systems.



Roberto Giral received the B.S. degree in Ingeniería Técnica de Telecomunicación, the M.S. degree in Ingeniería de Telecomunicación, and the Ph.D. (with honors) degree from the Universitat Politècnica de Catalunya, Barcelona, Spain, in 1991, 1994, and 1999, respectively. He is currently an Associate Professor with the Departament d'Enginyeria Electrònica, Elèctrica i Automàtica, Escola Tècnica Superior d'Enginyeria, Universitat Rovira i Virgili, Tarragona, Spain, where he is working in the field of power

electronics.

AUTHORS' ADDRESSES

Carlos Restrepo, M.Sc.

Prof. Javier Calvente, Ph.D.

Prof. Roberto Giral, Ph.D.

Departamento d'Enginyeria Electrònica, Elèctrica i Automàtica, Escola Tècnica Superior d'Enginyeria, Universitat Rovira i Virgili,

Avda. Països Catalans 26, Campus Sescelades, 43007, Tarragona, Spain

email: carlos.restrepo@urv.cat, javier.calvente@urv.cat, roberto.giral@urv.cat

Tine Konjedic, B.Sc.

Faculty of electrical engineering and computer science, University of Maribor,

Smetanova ulica 17, 2000, Maribor, Slovenia

email: tine.konjedic@uni-mb.si

Received: 2012-02-03

Accepted: 2012-03-21