

INDUCTION HEATING OF GEARS - PULSING DUAL-FREQUENCY CONCEPT

Received – Prispjelo: 2012-06-04
Accepted – Prihvaćeno: 2012-10-12
Preliminary Note – Prethodno priopćenje

The paper concerns analysis of gears hardening process. In order to obtain required temperature distribution several variations of single and combined frequencies for selected gear-wheel configurations were considered. The paper includes the calculation models and analysis of geometry and current intensity as well frequency influence on temperature distribution of the tooth surface. All calculations have been carried out by means of the use of Flux3D simulation program, which enables to provide, coupled electromagnetic and temperature fields analysis.

Key words: hardening process, induction heating, wheel gears, computer simulation

INTRODUCTION

The quality of the production process is evaluated basis on multiple criteria. Proper hardening of irregularly shaped work-pieces in contrast to a cylindrical shape is not an easy task. Method that can connect economic and ecological values for higher product quality is the induction hardening. Heating should provide an optimal temperature field, that is, uniform temperature in the surface of the tooth and the notch (above the temperature required for hardening), while the deeper layers should remain in the lower temperature, respectively. This makes it possible to obtain high hardness of the tooth surface while keeping some flexibility of the core wheel [1].

Obtaining the desired temperature distribution is not a simple issue. In order to achieve that inductors are often used by of sophisticated shapes. This solution is uneconomical (high cost of implementation) and not very universal (the inductor fits only a specific type and size of the wheel). Heating process can be made much easier by using the classical cylindrical inductors, but in such case it is very difficult to obtain required temperature field distribution. Usage of two, (or more) frequency of current can drastically improve the solution [2, 3, 4]. However, sometimes, the use of a cylindrical inductor is not possible. The results of quenching depend also on the number of teeth, height, or length of the tooth.

RESEARCH DESCRIPTION AND CALCULATION MODEL

The basic parameters are frequencies of induction heating and the heating time. They allow to control the

temperature distribution, which must be adapted to the contour of hardness, which should be obtained. In the case of gears, hardening takes place on the surface: this applies to both the side surface, and the tooth tip and root. With such a complex geometry obtain the desired surface temperature distribution is difficult. Quenching with use of the classical loop inductor produces large differences of temperature between the tip and root tooth. For the surface heating different treatments should be used. One of them is the use of multistage heating, using the inductor current of different frequencies [3, 4, 5,]. The final result depends on many parameters of such a process. In the simplest two-step process of heating the main parameters are:

- Heating time during stage 1 and 2,
- The frequency of the supply current in the inductor during stage 1 and 2,
- Final temperature of selected surface points obtained after stage 2,

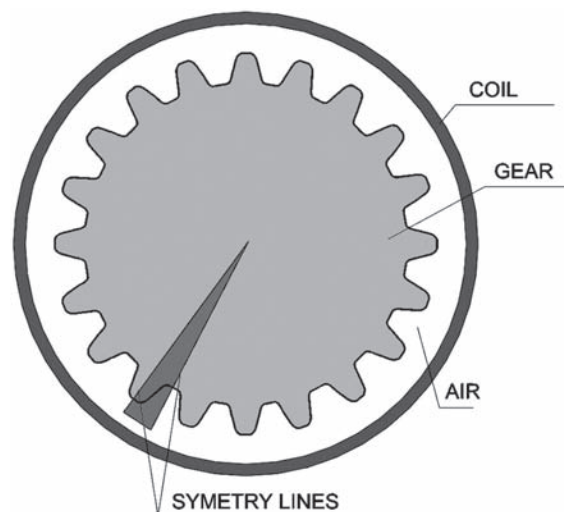

Figure 1 Calculation area

R. Przyłucki, A. Smalcerz, Silesian Technical University, Department of Metallurgy, Katowice, Poland

- Geometrical parameters of inductor (height, depth, position),
- The distance between the tip of the tooth and the coil.

In order to full analyze of the problem all possible combinations of several values of the selected parameter should be done. This requires an analysis of many of variants. In this project an attempt to analyze the impact of selected parameters for a single gear on the quenching process was made.

The paper concerns analysis of inductor position and height of the coil on the temperature distribution on the tooth surface. Due to symmetry of calculated objects analysis was conducted only for a small part of gear (quarter of a tooth). Analyzed area is shown in Figure 1.

The object of research is a gear. In all cases the of outer radius has 31,5 mm, 11 mm of inner radius and 6 mm of height. The wheel consists of 48 teeth and is placed inside of circular, one-turn inductor [6].

Depending on calculation variant the air gap between top of the tooth and inductor was between 5 to 10 mm and inductor was between 3 to 7,2 mm of height.

Calculations were carried out with the use of Flux3D program (version 9). In induction hardening process medium or high frequency usually is used. For test purposes 10 kHz is taken as medium frequency and 100 kHz as high frequency. Such high frequencies causes in strong skin effect. It is necessary to generate mesh with high element density in outer parts of wheel, because most of the power is produced in these parts. In the most important parts regular mesh of second order is used. To reduce number of elements the inductor winding was modeled as stranded coil.

In calculations pair of potentials is used: T and Φ according to the following equations [7]:

Wheel (charge) area:

$$J = \text{rot } T \tag{1}$$

$$H = T - \text{grad}\Phi \tag{2}$$

Air area:

$$H = H_j - \text{grad}\Phi \tag{3}$$

where: J – eddy current density, T – vector potential of electric field, Φ – scalar potential of magnetic, H – magnetic field intensity, H_j – magnetic field intensity calculated according to Biot-Savart law.

Boundary condition $\tilde{\Phi}=0$ is taken on outer border of the model, which is a result of magnetic field disappearing in big enough distance from heating system. Due to teeth symmetry on both its sides symmetry boundary condition was adopted (tangential magnetic field).

In high frequency calculations method of surface impedance is used, skin depth δ is too low to generate mesh of good enough quantity. Method of surface impedance is an assumption of power (and heat) generation only on wheel surfaces. In this case on surfaces following (4) border condition is adopted:

$$n \times \underline{E} = \underline{Z}_s n \times (n \times \underline{H}) \tag{4}$$

where n is normal vector to considered surface, \underline{E} – electric field intensity and \underline{Z}_s – complex surface impedance calculated according to equation (5) (ρ – electric resistivity of the charge):

$$\underline{Z}_s = (1+j)\rho/\delta \tag{5}$$

Thermal field calculations were conducted for tooth area only. Thermal field analysis basis on Fourier-Kirchhoff law (6) [8, 9]:

$$\nabla \cdot (\lambda \nabla T) = \rho c \frac{\partial T}{\partial t} - w \tag{6}$$

where: T – temperature, λ – thermal conductivity, $w = \rho |J|^2$ – volumetric power density.

Heat transfer between charge and air includes convection and radiation and is taken into consideration

It is no easy to estimate values of convection coefficient and emissivity because of fast rotating of the gear and proximity of inductor. Base upon review references $\alpha_k = 20 \text{ W}/(\text{m}^2\text{K})$ and $\epsilon = 0,5$ was taken for the calculation.

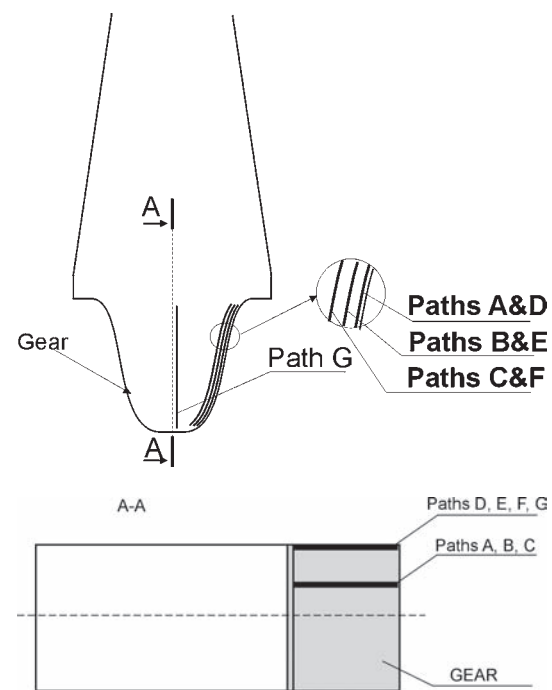

Figure 2 Location of temperature paths

The calculations take into account heating with use of two-step process, during the first step medium frequency is used and then high frequency. During hardening process temperature distribution is very important, so as results temperature field distribution and temperature in chosen points were monitored. Positions of these points are shown in Figure 2.

CALCULATIONS RESULTS

In this part of the paper influence of the geometrical parameters on temperature distribution of tooth surface was considered. The calculations consist of several var-

ients depending on variable parameter. Symbols' meaning used in calculations is described below:

- f_1 – frequency of inductor current during medium frequency (MF) stage (10 kHz),
- t_1 – heating duration of MF stage (1,5 s.),
- I_1 – intensity of inductor current (MF) (7 500 A),
- f_2 – frequency of inductor current during high frequency (HF) stage (100 kHz),
- t_2 – heating duration of HF stage (0,2 s.),
- I_2 – intensity of inductor current (HF) (3 600 A),
- k – tooth length (5 mm),
- n – teeth number (48),
- T_1 – maximum temperature after MF stage (≈ 700 °C),
- h – tooth height (6 mm),
- r – gear radius (26,5 mm),
- i – inductor height. ($3 \div 7,2$ mm),
- a - distance between the tooth and the inductor ($5 \div 10$ mm).

These last two parameters (i and a) describe calculation variants.

All heating processes consist of two stages. During first stage medium frequency (MF) of inductor current is used. When it is finished, final stage is carried out with use of high frequency current (HF). The picture (Figure 3) shows final temperature distribution on the tooth surface. The graphs (Figures 4-6) show the temperature value in the selected measurement paths. Temperature values are presented on the surface of the tooth (paths A & D), 0,2 mm from the surface of the tooth (paths B & E) and 0,4 mm from the surface of the tooth (paths C & F). Temperatures are shown on the edge of the tooth (paths D, E, F and G) and in the quarter of the tooth (paths B and C). In addition, the temperature is determined at points along the tooth (path G (Figure 2)).

Change of distance between the tooth and the inductor

The first parameter that changes during the experiment was the distance between the tooth and the inductor. To obtain correct temperature with the change of gap, also the power supply current value was changed, and have values as follow:

$$I_1 = 7,5 \text{ kA}, I_2 = 3,6 \text{ kA}$$

$$I_1 = 8,2 \text{ kA}, I_2 = 3,6 \text{ kA}$$

$$I_1 = 9 \text{ kA}, I_2 = 3,6 \text{ kA}$$

Variants of this part of experiment are described in Table 1.

Table 1 Simulation parameters

Variant	a – distance between the tooth and the inductor, i – height of inductor	
a1-i1	$a = 5$ mm	$i = 7,2$ mm
a2-i1	$a = 7,5$ mm	$i = 7,2$ mm
a3-i1	$a = 10$ mm	$i = 7,2$ mm

Change of height inductor

Another parameter that changes during the experiment was the height of inductor. Description of considered variants contain Table 2. In order to meet the conditions of heating wheels, with the change height of inductor, also changed the power supply current value:

$$I_1 = 7,5 \text{ kA}, I_2 = 3,6 \text{ kA}$$

$$I_1 = 7,4 \text{ kA}, I_2 = 3,6 \text{ kA}$$

$$I_1 = 7,4 \text{ kA}, I_2 = 3,6 \text{ kA}$$

Table 2 Simulation parameters

Variant	a – distance between the tooth and the inductor, i – height of inductor	
a1-i1	$a = 5$ mm	$i = 7,2$ mm
a1-i2	$a = 5$ mm	$i = 4,5$ mm
a1-i3	$a = 5$ mm	$i = 3$ mm

The last parameter that changes during the experiment was the distance between the inductors and the gear (Table 3).

$$I_1 = 7,5 \text{ kA}, I_2 = 3,6 \text{ kA}$$

$$I_1 = 7,4 \text{ kA}, I_2 = 3,8 \text{ kA}$$

$$I_1 = 7,4 \text{ kA}, I_2 = 4 \text{ kA}$$

Table 3 Simulation parameters

Variant	a – distance between the tooth and the inductor, i – height of inductor	
a2-i1	$a = 7,5$ mm	$i = 7,2$ mm
a2-i2	$a = 7,5$ mm	$i = 4,5$ mm
a2-i3	$a = 7,5$ mm	$i = 3$ mm

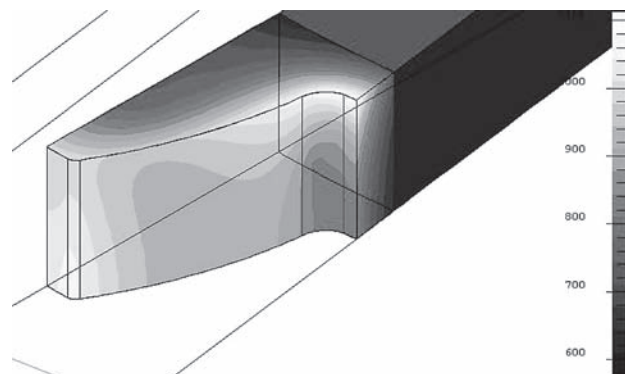

Figure 3 Variant a1-i1 - surface temperature after time 1,7s (1,5 s + 0,2 s)

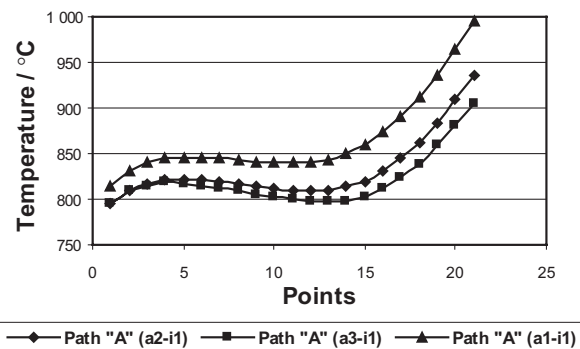

Figure 4 Effect of distance between the inductor and the gear on the temperature value for the path A

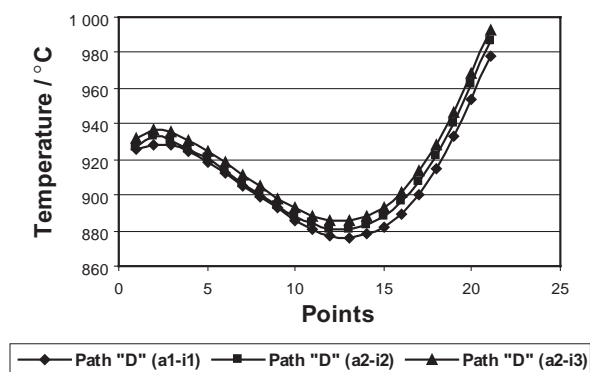

Figure 5 Effect of height of inductor on the temperature value for the path D

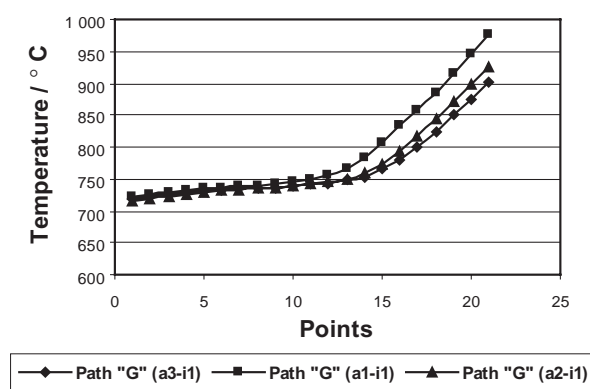

Figure 6 Effect of distance between the inductor and the gear on the temperature value for the path G

CONCLUSIONS

Analysis of the induction heating process of gear wheels seems to be a very complex process. This is mainly because of the large number of parameters that have a decisive influence on the final result. In addition, necessity of multiple calculations and change of the selected parameter in order to achieve the assumed temperature causes the large number of calculations.

For hardening process surface temperature of the tooth should be constant. Unfortunately in all cases tooth tip achieve higher temperature than its root. This

difference is connected with parameters showed in Figures 3 - 6. The main conclusions are:

- Shifting inductor from the wheel has influence on the uniformity of heating of the tooth wheel. With increasing distance between the wheel and the inductor, the tooth is heated more uniformly (Figure 4);
- Height of “non meshed” coil has small influence on the uniformity of heating of the tooth (Figure. 5);
- By using a pulsing dual-frequency concept (f_1 -10 kHz, f_2 -100 kHz) is achieved heating the tooth surface. In our case, a distance of 1 mm from the tooth surface temperature decreases by about 200 °C (Figure 6).

Application of pulsing dual-frequency concept heating increases control of temperature field distribution by changing the electrical and geometrical parameters. The resulting non-uniformity of temperature in selected points is about several percent.

Acknowledgement: This paper was supported by the Polish Ministry of Science and Higher Education under research project number: N N508 479438

REFERENCES

- [1] V. Rudnev, D. Loveless, R. Cook M. Black: Heat Treatment Of Metals, (2003) No 4, 97-103
- [2] Rudnev, V., et al.: Heat Treatment of Metals Part 2, (2004) No 1, 11-15
- [3] S. Lupi, F. Doughiero, M. Forzan: Conference Proceedings of EPM, (2006), 473-478
- [4] M. Niklewicz, A. Smalcerz: Przegląd Elektrotechniczny (2010) 5, 333-335
- [5] J. Barglik, A. Kurek, D. Dołęga, et al.: Proceedings of the 10th International Scientific Conference EPE, Czech Republic (2009)
- [6] Davis, J.R. Gear Materials, Properties, and Manufacture, ASM International, 2005.
- [7] M. Niklewicz, A. Smalcerz, A. Kurek: Przegląd Elektrotechniczny (2008) No 11, 219-224
- [8] Flux3D v.9.1 User's guide 2004
- [9] R. Przyłucki; S. Golak; B. Oleksiak, et al.: Metalurgija 51, (2012) 1, 61-70

Note: J. Przybyła is responsible for English language, Katowice, Poland