

Dynamic simulations of solar combisystems integrating a seasonal sorption storage: Influence of the combisystem configuration

Samuel HENNAUT¹⁾, Sébastien THOMAS¹⁾, Elisabeth DAVIN¹⁾, Alexandre SKRYLNYK²⁾, Marc FRERE²⁾ and Philippe ANDRE¹⁾

1) University of Liège, Building Energy Monitoring and Simulation
Av. de Longwy 185, B-6700 Arlon,
Belgium

2) University of Mons, Energy Research Center
Bd. Dolez 31, B-7000 Mons, **Belgium**

shennaut@ulg.ac.be

Keywords

*Seasonal storage
Solar combisystem
Bromide Strontium
Adsorption*

Ključne riječi

*Sezonski toplinski spremnik
Solarni kombi-sustav
Bromide Stroncij
Adsorpcija*

Primljeno (Received): 2012-04-20
Prihvaćeno (Accepted): 2012-10-15

1. Introduction

In a temperate or cold climate, seasonal thermal energy storage is necessary to reach a 100 % solar fraction for space heating. Using reaction enthalpy of the sorption phenomenon is an interesting way to store thermal energy. This kind of storage is particularly well suited for long-term storage because of its high storage density and of the absence of almost all thermal losses[1].

Previous researches [2, 3] have shown that autonomous solar space heating systems could be designed using this seasonal storage technology coupled to a ground heat exchanger used as a low temperature source. In these previous works, the combisystem was

Original scientific paper

This paper focuses on the sizing of solar combisystems with adsorption seasonal storage to target autonomous solar space heating. Two main configurations of the combisystem are simulated, including one or two tanks. The influence of the seasonal storage on the sizing of the tanks is also discussed. The analysis is conducted in simulation using the TRNSYS program. Results show that performances of the system with two tanks are better (2 to 4 % with seasonal storage) but some improvements should be possible for the single tank configuration. The sizing of the sensible storage is nearly independent of the solar collector area if there is a seasonal storage. The sensible storage size increases with the collectors' area without adsorption storage.

Dinamičke simulacije solarnih kombi-sustava sa sezonskim sorpcijskim spremnikom topline: Utjecaj konfiguracije kombi-sustava

Izvorni znanstveni rad

Ovaj članak je fokusiran na dimenzioniranje solarnog kombi-sustava sa sezonskim adsorpcijskim spremnikom topline sa ciljem autonomnog solarnog grijanja prostora. Dvije konfiguracije kombi-sustava su simulirane, uključujući jedan ili dva toplinska spremnika. Utjecaj sezonskog skladištenja energije na dimenzioniranje spremnika je također diskutirano. Analiza je vršena simulacijom u programu TRNSYS. Rezultati analize pokazuju da je performansa sustava sa dva spremnika bolja (2 do 4% sa sezonskim skladištenjem), ali i neka poboljšanja su moguća za konfiguraciju sa jednim toplinski spremnikom. Dimenzioniranje spremnika osjetne topline je gotovo neovisno od površine solarnih kolektora ako postoji sezonski spremnik. U slučaju bez adsorpcijskog spremnika, veličina spremnika osjetne topline se povećava sa povećanjem površine kolektora.

designed arbitrarily using two tanks, one for space heating (SH) and one for domestic hot water (DHW). This design identifies more easily the different heat flows associated with both purposes.

This paper deals with the analysis, by simulation, of the influence of the solar combisystem design on the complete system performances. The influence of the number of tanks and of the volume of the tanks is assessed. Additionally, the performance of these systems is evaluated without seasonal storage to quantify the influence of the storage utilization on the sizing of the system.

<u>Symbols/Oznake</u>	
E	- annual final energy demand, kWh - godišnja potrošnja energije
$F_{\text{sav, therm}}$	- fractional thermal energy savings - omjer uštede toplinske energije
Q	- annual thermal energy load, kWh - godišnje toplinsko opterećenje
<u>Greek letters/Grčka slova</u>	
ΔH_r	- heat of reaction, J - toplina reakcije
η	- mean annual efficiency - prosječna godišnja učinkovitost
<u>Subscripts/Indeksi</u>	
boiler,aux	- auxiliary boiler - pomoćni kotao
boiler,ref	- reference system boiler - kotao referentnog sustava
DHW	- for domestic hot water production - za proizvodnju potrošne tople vode
(g)	- gaseous - plinovito
(s)	- solid - kruto
SH	- for space heating - za grijanje sustava
TOT	- total, for the global system - ukupno, za cijeli sustav

2. Simulated systems

The simulated system includes the building, the sorption storage reactor and the solar combisystem. The dynamics simulations are realized with TRNSYS [4].

2.1. Seasonal storage

In the simulated systems the seasonal storage is carried out by a closed adsorption system using SrBr₂/H₂O as a working pair, according to the following reaction:

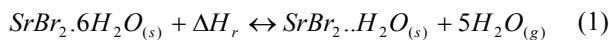

The working of the storage apparatus briefly described hereafter is given in more detail in [3] and [5]. The storage plant is composed of a chemical reactor containing the adsorbent and a tank used to store the condensed adsorbate. Both are linked and a valve allows or prevents mass transfer between the two parts when necessary. During the summer, solar heat is provided to the reactor to desorb water vapor which is condensed in the storage tank. During the winter, the stored water is evaporated at a low temperature level and adsorbed to the salt. Adsorption reaction heat is then released for SH. The evaporation and condensation of the adsorbate is supposed to be achieved using a ground heat exchanger (which is not simulated). The adsorbate evaporation and condensation temperatures are supposed to be constant: respectively 5°C and 20°C.

The model used for the chemical reactor is based on the “Detailed Modelling Approach” described in [5]. It computes dynamic energy and mass balances of the reactor and includes some kinetic aspects of the

reaction. Currently, this model is not yet experimentally validated.

2.2. Reference building

The simulated building, used in previous studies [2, 3, 5], is a “low-energy” single-family house. Its heating area is 100 m² shared between two floors and 40 m² of the roof are facing South with a slope of 40°. Set point temperatures for SH are permanently 20°C and 18°C respectively for the ground floor and the first floor. Uccle, in Belgium, is chosen as the given climate. The annual building heating demand is around 4200 kWh for SH and 2710 kWh for DHW.

2.3. Combisystems: 2 configurations

Two main configurations of the combisystem are considered. The first configuration uses two storage tanks, one for SH and another for DHW. The tank dedicated to SH is fed primarily by the solar loop. The second configuration includes only one tank for both purposes and DHW is produced using an external heat exchanger. For each configuration, outlets are located at the top of the tank both for SH and DHW. These two configurations are respectively illustrated in Figure 1 and Figure 2.

For all simulations realised for this study, the “space heating period” is considered to run from the 1st of October to the 30th of April. During this period, the maximum temperature allowed in the tank is fixed to 95°C (even this temperature is rarely reached).

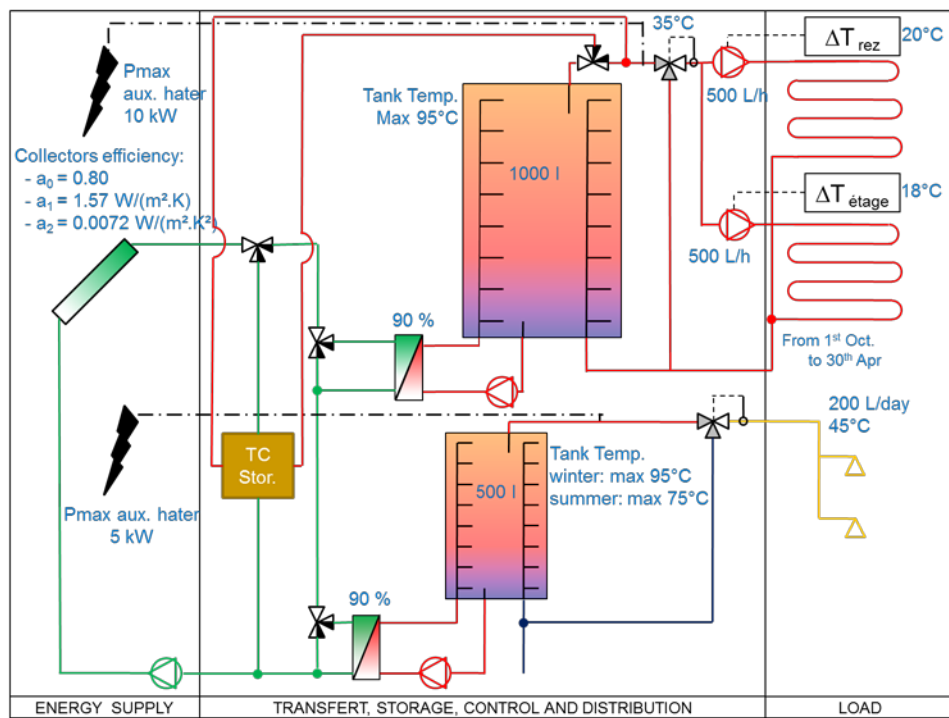

Figure 1. Configurations of the solar combisystem designed with 2 tanks

Slika 1. Konfiguracija solarnog kombi-sustava sa dva spremnika topline

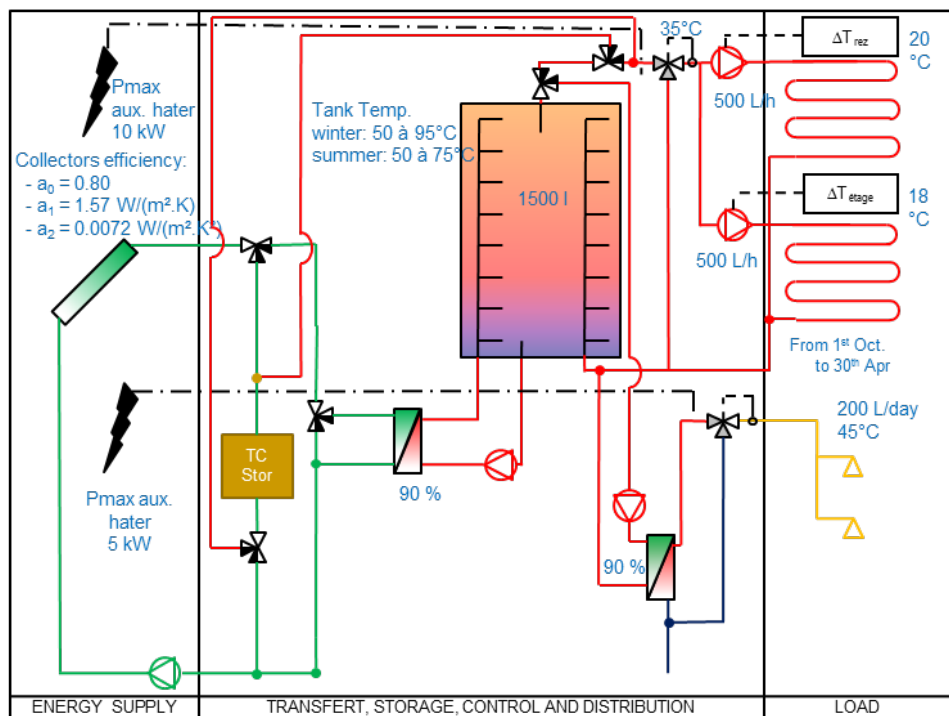

Figure 2. Configurations of the solar combisystem designed with 1 tank

Slika 2. Konfiguracija solarnog kombi-sustava sa jednim spremnikom topline

Outside this period, the building is not heated and the solar heat can be stored thermochemically if there is no need for DHW production. This part of the year running from the 1st of May to the 30th of September is consequently called the “storage period” for which the tank dedicated to SH (in the first configuration) is not used and the maximum temperature in the other (or single) tank is reduced to 75°C to increase solar heat available for seasonal storage.

The simulated solar collectors are flat plate collectors with high efficiency values which are targeted into the frame of this research project:

- Optical efficiency (a_0) = 0,80;
- Linear loss coefficient (a_1) = 1,57 W/(m²K)
- Quadratic loss coefficient (a_2) = 0,0072 W/(m²K²)

The emission device chosen for SH is composed of a water-based floor heating fed at a maximum temperature of 35°C. For both configurations, two instantaneous auxiliary heaters are used. One for SH, which is added between the tank and the floor heating to reheat the water leaving the tank (or the storage reactor) to 35°C if the set point is not reached in the building with lower temperature, and another for DHW which guarantees a temperature of 45°C for DHW users.

2.4. Seasonal storage integration

The storage reactor is integrated in the solar combisystem, both in the solar loop and in the SH distribution system (see Figures 1 and 2). The thermochemically stored heat is only dedicated to the building heating. It's not used for DHW production because of the temperature level which can be reached using the chosen adsorbent/adsorbate couple. During winter, the seasonal storage is used as an instantaneous auxiliary heater for SH. The water leaving the tank is reheated by the thermochemical reactor if the temperature of the reactor is higher. Otherwise, the tank water is directly provided to the emission system.

The storage reactor is composed of one big module containing the totality of the reactant salt and achieving only one cycle per year (charging during summer and discharging during winter). If the salt is completely desorbed before the end of the storage period, the reactor is used as a sensible storage medium until the beginning of the heating period.

3. Methodology

Both configurations of the combisystem described above are compared, with and without seasonal storage.

For each configuration, different values were tested for the following parameters:

- Solar collectors area
- Volume of the tanks: DHW and SH or a single tank
- Adsorbent mass

The tested values are summed up in Table 1.

Performances of the simulated systems are evaluated using the “fractional thermal energy savings” indicator ($f_{sav,therm}$) developed in the framework of IEA-SHC Task 26 [6]:

$$F_{sav,therm} = 1 - \frac{E_{boiler,aux}}{E_{ref}} = 1 - \frac{\frac{Q_{boiler,aux}}{\eta_{boiler,aux}}}{\frac{Q_{boiler,ref}}{\eta_{boiler,ref}}} \quad (2)$$

$F_{sav,therm}$ is computed for DHW production ($F_{sav,DHW}$), for the SH energy consumption ($F_{sav,SH}$) and for the global system ($F_{sav,TOT}$). The reference consumption ($Q_{boiler,ref}$) for the DHW and SH are respectively around 2710 and 4200 kWh. The same efficiency (η) is considered for the reference system and for the auxiliary heaters, i.e. 85 %. For the global system, the reference consumption is the sum of the consumptions for DHW and SH. This indicator will help to compare the two configurations' performance but also in discussing the system sizing methodology with and without seasonal storage.

4. Results and analysis

4.1. Without seasonal storage

If the thermochemical seasonal storage is not used, both configurations reach almost the same performances for the complete system, with a small advantage (less than 1%) for the *two-tank* system. This observation is illustrated in Figure 3.

In this figure, for each collector area tested, the $F_{sav,TOT}$ for the *best case* and the volume of the corresponding tank are plotted. Here, the *best case* is defined as the case allowing the achievement of, with the smallest sensible storage volume, at least the maximum value computed for $F_{sav,TOT}$ minus 1%. For these *best cases*, the volumes of the tank are quite close for both configurations.

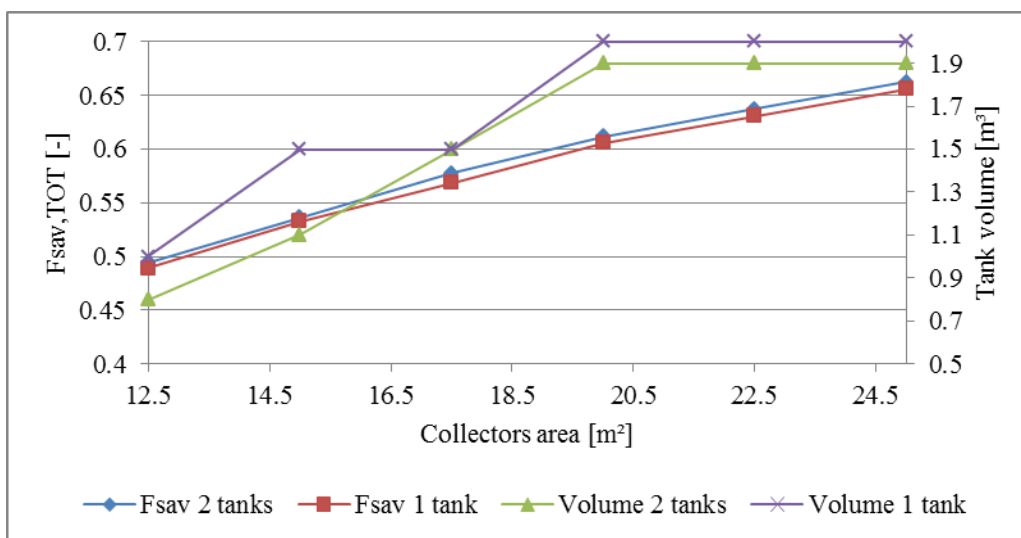

Figure 3. $F_{sav,TOT}$ and tank volume for *best cases* without seasonal storage

Slika 3. $F_{sav,TOT}$ i volumen spremnika [m³] za najbolje slučajeve bez sezonskog spremnika topline.

4.2. With seasonal storage

tanks increases the $F_{sav,TOT}$ by around 4 % compared to the configuration with a single tank.

If the solar system integrates the thermochemical reactor, the advantage of the first configuration (2 tanks) becomes greater. For a large collectors area, using two

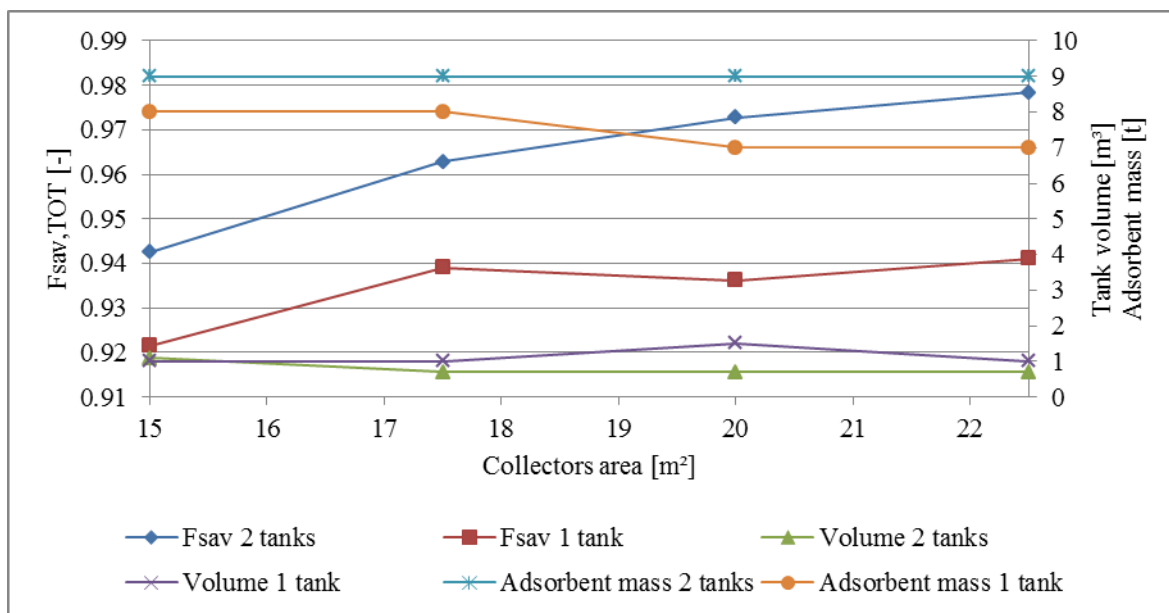

Figure 4. $F_{sav,TOT}$ and tank volume for *best cases* with seasonal storage

Slika 4. $F_{sav,TOT}$ i volumen spremnika [m³] za najbolje slučajeve sa sezonskim spremnikom topline.

With seasonal storage, the *best case* is defined as the case allowing the achievement of at least the maximum value computed for $F_{sav,TOT}$ minus 1% with the smallest adsorbent mass (among cases with the smallest

adsorbent mass, the one with the smallest sensible storage volume is chosen). These *best cases* are shown in Figure 4 for each collector area. For the configuration with one tank, the masses of adsorbent computed are

lower than those for the system with two tanks, but the $F_{\text{sav,TOT}}$ values are also lower. The results show that with two tanks, for an equal mass of salt, results are better (up to 2%) than with one tank. In most cases, the configuration has little influence on the required volume for the sensible storage.

The comparison of the F_{sav} computed for the *best cases* with and without seasonal storage shows that, for identical areas of collectors, the thermochemical storage allows saving between 30 and 40 %. It's also shown that the sizing of the storage tank won't be the same if some seasonal storage occurs. Figure 3 shows that it's interesting to increase the sensible storage volume when the collectors' area increases, if there is no seasonal storage. Conversely, with seasonal storage, a tank volume around 1 m³ allows for the achievement of the best performance regardless of the collectors' area (see Figure 4).

Some of the *best cases* selected don't allow for an autonomous SH system with solar energy ($F_{\text{sav,SH}} > 0.99$). But if the *best cases* are selected among those capable of reaching the autonomy for SH, the conclusions are similar.

4.3. Case study: 1.5 m³ sensible storage, 22.5 m² collectors and 7000 kg adsorbent

Both configurations are studied in detail for a fixed storage volume (1.5 m³) in this section. For the single-tank configuration, the sensible storage is made up of 0.5 m³ for DHW and 1 m³ dedicated to SH. The performances of the global system and of the SH are illustrated in Figure 5, for different collectors areas and a variable mass of adsorbent. It's shown that, in most cases, the performances are slightly better with two tanks than with one.

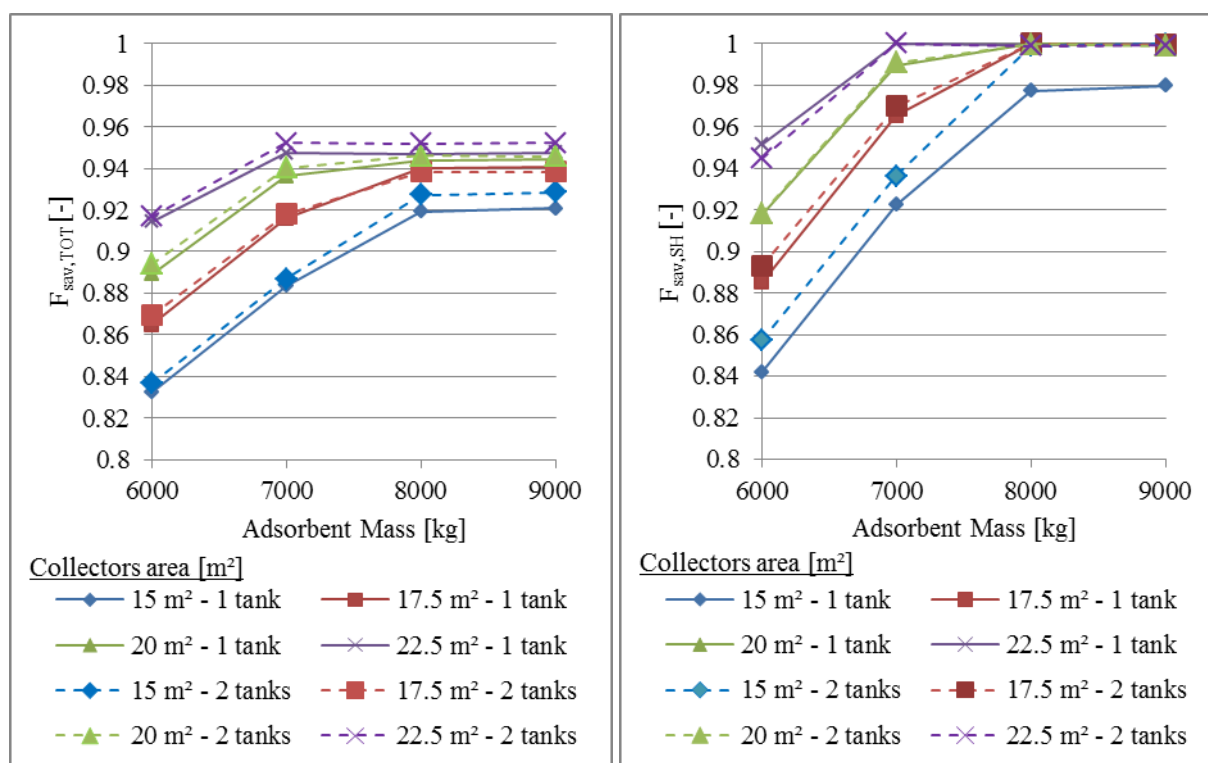

Figure 5. Comparison of the performance of the two configurations with a sensible storage of 1.5 m³, for the global system (on the left) and for SH only (on the right)

Slika 5. Usporedba performansi dviju analiziranih konfiguracija sa spremnikom osjetne topline od 1.5 m³ : za ukupni sustav (lijevo) i samo sustav za grijanje prostora (desno).

Some explanations can be found by the analysis of the following particular case: a comparison of the energy balances is done for a solar system with 1.5 m³ of sensible storage, 22.5 m² of collectors and 7000 kg of adsorbent. In this case, the lower performance of the

single-tank configuration can be explained by the following observations and assumptions.

- During summer, there are more solar gains in the single storage tank (see Fig. 6, left). We assume that in this configuration the single tank is too large for summer operation, which reduces the

solar energy available for seasonal storage (see Fig. 6, right). Stored heat becomes insufficient at the end of winter (see Fig. 6, right and 7, left). In the two-tank configuration, only the DHW tank is used during the summer, which makes more solar heat available for seasonal storage.

- During the winter, the solar gains in the single tank are lower (see Fig. 6, left) probably because it is hotter than the DHW tank in the single-tank configuration.

- An increasing consumption of the auxiliary heating energy used for DHW is observed in February and March (See Fig. 7, right). It seems that at the end of the SH period, when the thermochemical storage is “empty”, the important flow rate in the single tank reduces the stratification in the tank and consequently the performance of the DHW production.

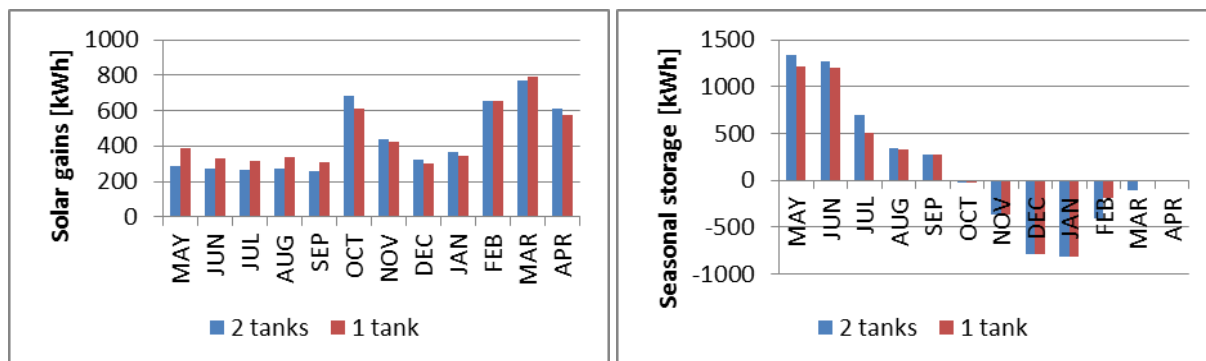

Figure 6. Solar gains in the tanks (on the left) and seasonal thermochemical storage (on the right)

Slika 6. Solarna dovedena količina topline u spremnicima (lijevo) i sezonska termo-kemijska uskladištena toplina (desno)

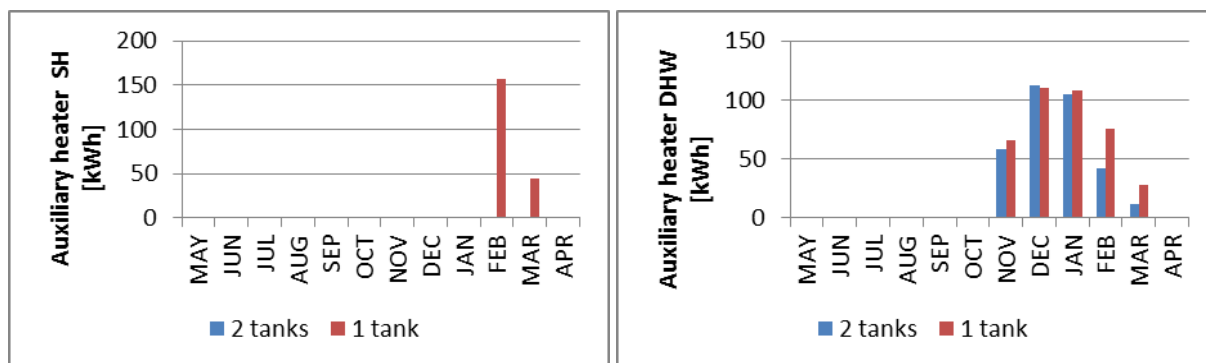

Figure 7. Auxiliary heating needs for SH (on the left) and for DHW (on the right)

Slika 7. Pomoćna količina topline potrebna za grijanje prostora (lijevo) i potrošne tople vode (desno)

5. Conclusions and outlook

The results show that the performances of both configurations are almost the same without seasonal storage. If the thermochemical storage is used, the configuration with two tanks allows increasing the fractional thermal energy savings of the complete system from 94 to 98 % in the best case illustrated. For the configuration with a single tank, a plateau seems to be reached for an F_{sav} around 94 %.

This conclusion wasn't expected. Actually, the objective of using one tank instead of two was first to reduce thermal losses through the wall of the tanks and to increase the thermal performances of the system in this way. The high insulation simulated for the tanks ($0.53 \text{ W}/(\text{m}^2\cdot\text{K})$) has probably reduced this impact on the system behaviour. Nevertheless, the single tank solution allows reducing the bulk of the system and the investment cost. Some modification may also be investigated to increase the performances of this configuration. For instance, reducing the maximal

temperature in the tank during the summer should make more solar heat available for seasonal storage while ensuring the solar production of DHW.

Another issue of the configuration with a single tank is the production of the DHW. The simulated external unit requires the use of instantaneous auxiliary heating which is difficult to provide without connection to the natural gas network. Additionally, the intention to heat the building with renewable energy merely won't allow for the heating of the single storage tank with non-renewable energy sources.

If the sizing of the sensible storage seems to be very close for both configurations, some differences appear if we compare the systems with or without seasonal storage. As expected, for a system without seasonal storage, it is interesting to increase the sensible storage capacity with the collectors' area. But if the storage reactor is used, the sensible storage has to be around 1m^3 .

Future work will focus on new combisystem configurations, especially to improve the performance of the single tank configuration. The modification of the position of the outlet for space heating could also increase the performance of the system. Future work will study the influence of the position of this outlet as well as the influence of the choice of an internal heat exchanger which should reduce internal water flows in the tank.

Acknowledgements

Research presented in this paper is conducted in the SOLAUTARK project with the following partners: ESE, ArcelorMittal Liège R&D, Atelier architecture Ph. Jaspard, ULB, CTIB, M5, UMons, and ULg. This project is funded by the Plan Marshall of the Walloon Region.

REFERENCES

- [1] K. E. N'Tsoukpoe, H. Liu, N. Le Pierrès, and L. Luo, "A review on long-term sorption solar energy storage," *Renewable and Sustainable Energy Reviews*, vol. 13, pp. 2385-2396, 2009.
- [2] S. Hennaut, S. Thomas, P. Andre, E. Courbon, T. Berigot (Le), and M. Frère, "Pré-dimensionnement par simulations dynamiques d'un réacteur de stockage thermo-chimique assurant l'autonomie d'un système solaire combiné," presented at the Congrès Français de Thermique 2011 - Energie Solaire et Thermique, Perpignan, 2011.
- [3] S. Hennaut, S. Thomas, E. Davin, and P. Andre, "DYNAMIC SIMULATION OF RESIDENTIAL BUILDINGS WITH SEASONAL SORPTION STORAGE OF SOLAR ENERGY- PARAMETRIC ANALYSIS," presented at the ISES solar world congress 2011, Kassel, Germany, 2011.
- [4] "TRNSYS," 17.00.0019 ed. Madison, Wisconsin, USA: Solar Energy Laboratory - University of Wisconsin, 2010.
- [5] A. Skrylnyk, E. Courbon, M. Frère, S. Hennaut, P. Andre, P. Sun, and G. Descy, "Modelling of a solar thermo-chemical system for energy storage in buildings," presented at the Innostock 2012 - The 12th International Conference on Energy Storage, Lleida, Spain, 2012.
- [6] T. Letz, "Validation and background information on the FSC procedure," IEA SHC2002.