

# Compensation of Integrated Resonant and Time Delay System by Using Wave Compensator

DOI 10.7305/automatika.54-1.322  
UDK 629.3.015.5-23-56; 004.896  
IFAC 3.2.1.9; 1.2.1

Original scientific paper

Recently, teleoperated robots have been researched for working in ultimate environment actively. Developing performance of teleoperated robots, it will be possible for human to work in such a ultimate environment with safety. However, in the actual case, a flexible mechanism caused by the mechanical constraint such as weight saving of robot, using gear, and so on, induces vibration. Moreover, a communication delay causes vibration, too. In addition, in the worst case, the delay makes the control system unstable. Therefore, in this paper, for suppressing the vibration, compensation of integrated resonant and time-delay systems by using a wave compensator is proposed. In the proposal, there are two important control structures. Firstly, a reflected wave in the resonant system is eliminated by a reflected wave rejection. A transfer function of wave equation without the reflected wave is represented as a time delay. Therefore, a resonant system without a reflected wave can be regarded as an equivalent time-delay system. Next, it is defined that an effect of time delay from resonant and communication systems is caused by a time-delay disturbance. Then, vibrations from resonant and communication delays are simultaneously suppressed by the wave compensator. Finally, the validity of the proposal is verified by simulation and experimental results.

**Key words:** Reflected wave rejection, Vibration control, Time delay, Wave equation, Wave compensator

**Kompensacija sustava s rezonancijom i vremenskim kašnjenjem pomoću valnog kompenzatora.** U posljednje vrijeme daljinski upravljani roboti za rad u izazovnim okruženjima dobivaju na važnosti. Poboljšanje sposobnosti daljinski upravljanih robota neosporno bi omogućilo bi sigurniji rad u takvim okruženjima. Ipak, realne robotske konstrukcije često podrazumijevaju fleksibilne prijenosne mehanizme, zupčanike i druge elemente koji unose nepoželjne vibracije u sustav. Fenomen vibracije dodatno je naglašen i vremenskim kašnjenjem u komunikaciji s robotom što može u konačnici uzrokovati nestabilno ponašanje. U ovom se radu predlaže mehanizam sprječavanja vibracija temeljen na kompenzatoru valova. Mehanizam se sastoji od dvije cjeline. Prvi korak je eliminacija reflektiranog vala. Drugo, prijenosna funkcija valne jednadžbe bez reflektiranog vala tretira se kao vremensko kašnjenje. Stoga se rezonantni sustav može promatrati kao ekvivalentni sustav s vremenskim kašnjenjem. Nadalje, utjecaj se vremenskog kašnjenja modelira kao poremećaj s vremenskom odgodom. U konačnici se vibracije rezonantnog i komunikacijskog kašnjenja potiskuju kompenzatorom valova. Predloženi je algoritam ispitan u simulacijama kao i na stvarnome sustavu.

**Ključne riječi:** odbacivanje odbijenog vala, vremensko kašnjenje, kontrola vibracija, valna jednadžba, valni kompenzator

## 1 INTRODUCTION

Recently, teleoperated robots have been researched for working in ultimate environment actively. For example, there are robots for space, for atomic power plant, for micro-manipulation, etc [1]. Developing performance of the teleoperated robots, it will be possible for human to work in such a ultimate environment with safety. Moreover, a motion control technology of the robots has been developing with the performance enhancement of the computer. So, in a near future, it is thought that it is possible to

teleoperate robots accurately and rapidly.

For realizing the teleoperated robots, there are two problems which should be solved. One is a vibration on the robots caused by a mechanical resonance. In actual case, mechanical constraint such as reduction of mass, using gear, and so on, reduces mechanical stiffness, and, reduction of stiffness causes a vibration. The vibration induces degradation of task accuracy and destruction of materials in the worst case. Second is a time delay in the communication system. Feedback of position information

including time delay causes a vibration or the system becomes unstable in the worst case.

It is important for teleoperation systems to consider vibration from both the flexible structure and the communication delay. Therefore, in this paper, vibration control of the system with the flexible mechanism and the communication delay is focused on.

A lot of methods of vibration control and time-delay compensation have been researched. As for conventional vibration control methods, state feedback control [2],  $H_\infty$  control [3],  $\mu$ -synthesis [4], wave control [5–7] and resonant ratio control [8, 10] have been researched. Especially, a resonant ratio control has a simple control structure and physical meaning of that is clear. Resonant ratio control is a vibration control method based on feedback of torsional torque which is estimated by a reaction force observer (RFOB) [11]. On the other hand, as for conventional time-delay compensation methods, there are Smith predictor [12] and a communication disturbance observer (CDOB) [13–15], and so on. In particular, compared with Smith predictor, CDOB doesn't need time delay model. However, CDOB needs plant model and inverse model. So, for control of teleoperation system, only integrated resonant ratio control with communication disturbance observer makes sometimes system unstable because of existing error of plant model.

Therefore, in this paper, a novel vibration control method of a resonant system with communication delay is proposed. In the proposal, a resonant system is modeled as a wave equation and a transfer function of the wave equation is used for design of vibration control of resonant system. The authors proposed a method of eliminating reflected wave [16] and a resonant system without a reflected wave can be regarded as a time-delay system. However, feedback of output including time delays from the resonant system and the communication system causes the vibration at the load side of the system. Therefore, as the time-delay compensation method, a wave compensator has been proposed. Originality and advantage of this paper is that vibrations from resonant system and communication delay can be simultaneously suppressed by using the wave compensator. Moreover, plant parameter used in the proposed method is only time-delay model of the resonant system in the reflected wave rejection and it is not so sensitive to stability of the system. Thus, vibration suppression can be achieved by the proposed method without becoming the system unstable. The authors have already proposed the vibration control of resonant system with communication delay by using the wave compensator [17]. In this paper, more detail about theory of the reflected wave rejection and analysis by simulation and wave compensator are added. In the simulation, the effect of the reflected wave rejection

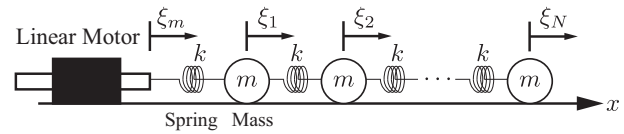

Fig. 1. Multi-mass resonant system.

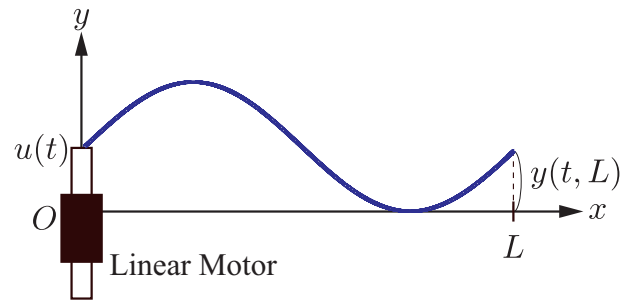

Fig. 2. Resonant system modeled as wave equation.

is confirmed and the ability of high order vibration suppression is verified in a three-mass resonant system.

This paper is organized as follows. At first in Section 2, a modeling of resonant system is explained, and an acceleration-control system is introduced. In Section 3, firstly, a method of reflected wave rejection is described. In addition, for suppression of vibration from the resonant system and communication delay, a wave compensator which is the time-delay compensation method based on CDOB is proposed. In Section 4, simulations are conducted in order to verify the performances of the reflected wave rejection and the wave compensator. In order to verify the effectiveness of the proposed method, experimental results are shown in Section 5. Finally, this paper is concluded.

## 2 MODELING

A system which is treated in this paper is described as flexible manipulator like Fig. 1 and 2. In this system, control goal is that tip position corresponds to position command without vibration in transient and steady-state phases. In this section, the resonant system without communication system is modeled.

### 2.1 Resonant System

Firstly, it is explained that when number of particles  $N$  approaches infinity, motion equations of  $N$ -mass resonant model become equivalent to a wave equation.  $N$ -mass resonant system is shown in Fig. 1. In this paper, a position input by a linear motor is applied in a boundary of the system. In addition, the other boundary is set to free end.

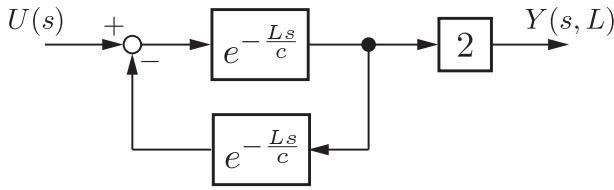

Fig. 3. Block diagram of wave equation.

The motion equation of the  $N$ -mass resonant system is represented as

$$\begin{aligned}
 m\ddot{\xi}_1 &= k(\xi_m - 2\xi_1 + \xi_2) \\
 &\vdots \\
 m\ddot{\xi}_i &= k(\xi_{i-1} - 2\xi_i + \xi_{i+1}) \\
 &\vdots \\
 m\ddot{\xi}_N &= k(\xi_{N-1} - \xi_N)
 \end{aligned} \tag{1}$$

where  $m$ ,  $\xi$ , and  $k$  denote the mass, displacement, spring coefficient respectively. Subscripts  $i$  ( $1 \leq i \leq N$ ) and  $m$  denote particle number and motor respectively. Here, boundary conditions of (1) are represented as

$$\xi_0 = \xi_m \tag{2}$$

$$\xi_{N+1} = \xi_N \tag{3}$$

where  $\xi_{N+1}$  denotes the position of virtual particle. By using (2) and (3), motion equations of all particles ( $1 \leq i \leq N$ ) become same expression. The motion equation of  $i$ -th particle is represented as

$$m\ddot{\xi}_i = k(\xi_{i-1} - 2\xi_i + \xi_{i+1}) \tag{4}$$

Now, if the maximum number of particles  $N$  approaches infinity, (4) comes down to a wave equation represented as

$$\frac{\partial^2 y(t, x)}{\partial t^2} = c^2 \frac{\partial^2 y(t, x)}{\partial x^2} \tag{5}$$

$$c = \sqrt{\frac{ka^2}{m}} \tag{6}$$

where  $y(t, x)$ ,  $c$ , and  $a$  denote the displacement in  $t$  at  $x$ , propagation velocity of the wave, and length of a spring respectively. Furthermore, the boundary conditions are represented as

$$y(t, 0) = u(t) \tag{7}$$

$$\frac{\partial y(t, L)}{\partial x} = 0 \tag{8}$$

where  $u(t)$  and  $L$  denote the position input and the length of system. In this paper, (7) means that the position input

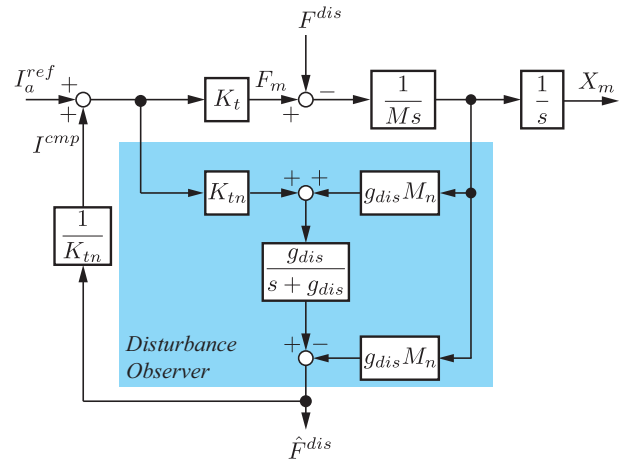

Fig. 4. Block diagram of acceleration control based on disturbance observer.

is applied by the linear motor at  $x = 0$  and (8) means that the system at  $x = L$  is free end. Moreover, the initial conditions are represented as

$$y(0, x) = 0 \tag{9}$$

$$\frac{\partial y(0, x)}{\partial t} = 0 \tag{10}$$

The resonant system modeled as the wave equation is shown in Fig. 2. Using (7)–(10), a transfer function from  $Y(s, 0)$  to  $Y(s, L)$  is derived as

$$\begin{aligned}
 G(s, L) &= \frac{Y(s, L)}{Y(s, 0)} \\
 &= \frac{2}{e^{\frac{Ls}{c}} + e^{-\frac{Ls}{c}}} \\
 &= \frac{2e^{-\frac{Ls}{c}}}{1 + e^{-\frac{2Ls}{c}}}
 \end{aligned} \tag{11}$$

where  $s$  denotes the Laplace operator. It turns out that the transfer function of the wave equation is composed of time delay elements. The block diagram of (11) is shown in Fig. 3. In Fig. 3, negative feedback represents a reflected wave against the input. From a point of view of the wave, a superposition of traveling and reflected waves causes vibration.

### 2.2 Acceleration Control Based on Disturbance Observer

In order to apply the position input which is robust against disturbances to the resonant system, a disturbance observer (DOB) [18, 19] is implemented. A block diagram of acceleration control based on a disturbance observer is shown in Fig. 4. In Fig. 4,  $g_{dis}$ ,  $I_a^{cmp}$ ,  $M$ ,  $K_t$  and  $I_a^{ref}$

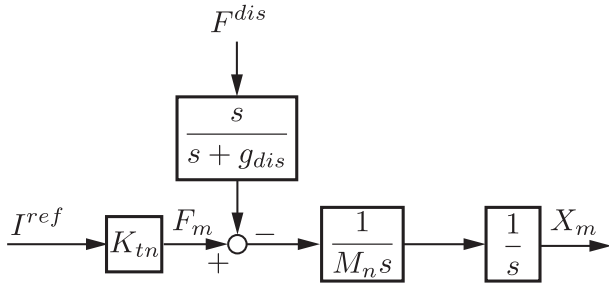

Fig. 5. Equivalent block diagram of Fig. 4.

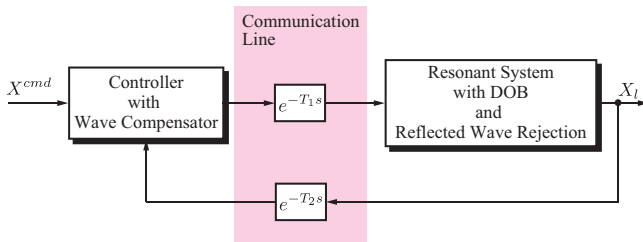

Fig. 6. Overview of the proposed teleoperated system.

represent the cut-off frequency, the compensation current, the mass, the torque coefficient and the current reference, respectively. Subscript  $n$  denotes the nominal value. In this paper, a disturbance is defined as

$$F^{dis} = F_{reac} + F_c + D\dot{X}_m + \Delta M\ddot{X}_m - \Delta K_t I_a^{ref} \quad (12)$$

where  $X_m$ ,  $F_{reac}$ ,  $F_c$ ,  $D$ , and  $\Delta$  denote the position of motor, the reaction force, the coulomb friction, the viscous friction coefficient, and the variation, respectively. From Fig. 4, the disturbance is estimated through a low-pass filter, which is represented as

$$\hat{F}^{dis} = \frac{g_{dis}}{s + g_{dis}} F^{dis} \quad (13)$$

The equivalent block diagram of Fig. 4 is shown in Fig. 5. From Fig. 5, it turns out that feedforward of the estimated disturbance shown in Fig. 4 is equivalent to apply a high-pass filter to the disturbance. Therefore, if  $g_{dis}$  approaches infinity, the disturbance is eliminated perfectly. In this situation, dynamics of the motor is represented as follows,

$$X_m = \frac{1}{s^2} \ddot{X}^{ref} \quad (14)$$

where  $\ddot{X}^{ref}$  denotes the acceleration reference.

### 3 VIBRATION CONTROL OF RESONANT SYSTEM WITH COMMUNICATION DELAY

In this section, the proposed vibration control method is explained. Overview of the proposed control method

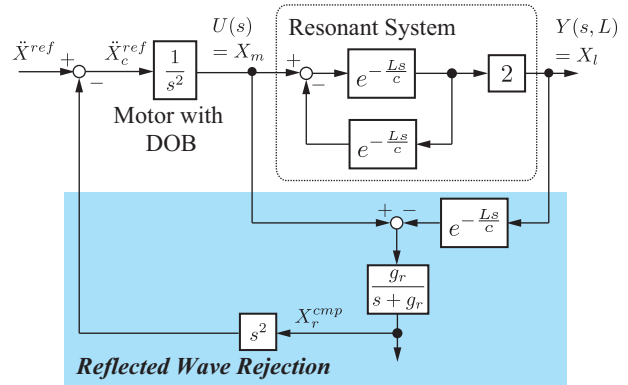

Fig. 7. Block diagram of the reflected wave rejection.

is shown in Fig. 6. In the proposal, a controller and a wave compensator which is the proposed method are implemented at the local side. On the other hand, at the remote side, a disturbance observer and a reflected wave rejection are implemented.

#### 3.1 Reflected Wave Rejection

In this part, the reflected wave rejection for vibration suppression of the resonant system is explained. First of all, the transfer function (11) is transformed and an equation is derived as follow,

$$Y(s, L) = 2e^{-\tau s} U(s) - e^{-2\tau s} Y(s, L) \quad (15)$$

where  $\tau$  denotes the propagation time of the wave, which is represented as

$$\tau = \frac{L}{c} \quad (16)$$

In (15), the second term in the right part means the reflected wave. For eliminating the reflected wave, a feedback is conducted and it is represented as

$$\begin{aligned} \ddot{X}_c^{ref} &= \ddot{X}^{ref} - s^2 X_r^{cmp} \\ &= \ddot{X}^{ref} - \frac{s^2 g_r}{s + g_r} (X_m - e^{-\tau_n s} Y(s, L)) \end{aligned} \quad (17)$$

where  $\ddot{X}_c^{ref}$ ,  $X_r^{cmp}$  and  $g_r$  denote the acceleration reference including the compensation value, the compensation value for eliminating the reflected wave and the cut-off frequency of the compensation value. Subscript  $n$  denotes the nominal value. It is assumed that the cut-off frequency of the reflected wave rejection  $g_r$  equals to infinity. Applying (17) to the resonant system represented as (15), (15) is

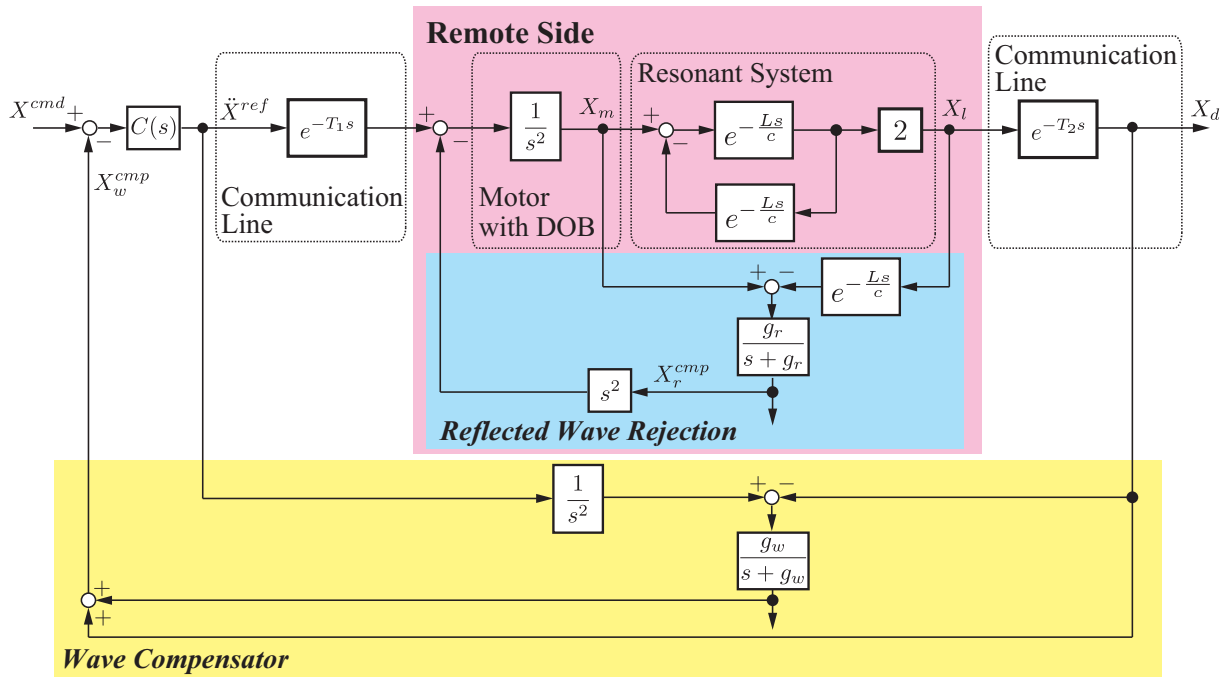

Fig. 10. Block diagram of the proposed control system.

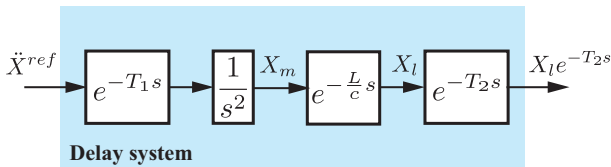

Fig. 8. Block diagram of time-delay system.

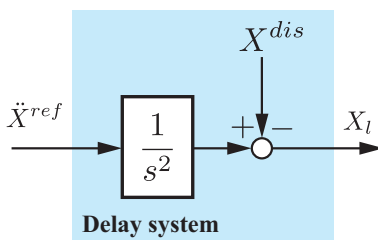

Fig. 9. Block diagram of time-delay system considering time delay disturbance.

transformed into

$$\begin{aligned}
 Y(s, L) &= 2e^{-\tau s} \frac{1}{s^2} \ddot{X}^{ref} - e^{-2\tau s} Y(s, L) \\
 &= \frac{1}{s^2} e^{-\tau s} \ddot{X}^{ref} \\
 &\quad - \left( e^{-2\tau s} - e^{-(\tau+\tau_n)s} \right) Y(s, L) \quad (18)
 \end{aligned}$$

If the nominal time delay corresponds to the actual time delay, the transfer function from the acceleration reference  $\ddot{X}^{ref}$  to the load position  $Y(s, L)$  is represented as

$$Y(s, L) = \frac{1}{s^2} e^{-\tau s} \ddot{X}^{ref} \quad (19)$$

In (19), it is found that there is no time delay in the denominator of the transfer function. It implies that vibrations caused by resonances are suppressed. It turns out that the transfer function is expressed as one-time delay and integrators. Therefore, by using the reflected wave rejection, the resonant system is transformed into the equivalent time-delay system. Finally, the block diagram of the reflected wave rejection is shown in Fig. 7.

### 3.2 Wave Compensator

In this part, a position control system is designed for the controlled plant represented as (19). For designing the control system, a feedback of load position is conducted. However, the feedback including time-delay elements causes vibration at the load side of resonant system. There is not only time delay of the resonant system but also communication delays.

For suppression of the vibrations from these time delays, a wave compensator is proposed. The compensator is based on CDOB which is the time-delay compensation method used in the field of a communication system. A

concept of the wave compensator is that the vibration is caused by the time-delay disturbance. The time-delay disturbance  $X^{dis}$  is defined as

$$\begin{aligned} X^{dis} &= \frac{1}{s^2} \ddot{X}^{ref} - X_l \\ &= \frac{1}{s^2} \ddot{X}^{ref} - \frac{1}{s^2} \ddot{X}^{ref} e^{-\left(\frac{L}{c} + T_1 + T_2\right)s} \end{aligned} \quad (20)$$

where  $T_1$  and  $T_2$  denote communication delays. Using the time-delay disturbance, time-delay system shown in Fig. 8 is transformed into time-delay system shown in Fig. 9.

The wave compensator can estimate and compensate the time-delay disturbance. The block diagram of the proposed control system including the wave compensator is shown in Fig. 10. In Fig. 10,  $X^{cmd}$  denotes the position command. The time-delay disturbance is estimated through a low-pass filter represented as

$$\hat{X}^{dis} = \frac{g_w}{s + g_w} X^{dis} \quad (21)$$

where  $g_w$  denotes the cut-off frequency. The compensation value  $X_w^{cmp}$  represented as (22) is generated by using (21).

$$X_w^{cmp} = X_l + \hat{X}^{dis} \quad (22)$$

When the cut-off frequency is large enough, (22) is transformed into

$$X_w^{cmp} = \frac{1}{s^2} \ddot{X}^{ref} \quad (23)$$

Therefore, it is possible that the motor and the load are regarded as a rigid body. Moreover, if PD controller is used as a position controller, the acceleration reference applied to the motor is represented as

$$\ddot{X}^{ref} = K_p(X^{cmd} - X_w^{cmp}) + K_v s(X^{cmd} - X_w^{cmp}) \quad (24)$$

where  $K_p$  and  $K_v$  denote the position control gain and the velocity control gain, respectively. In addition, a transfer function from the position command  $X^{cmd}$  to the load position  $X_l$  is derived as

$$\frac{X_l}{X^{cmd}} = \frac{K_p}{s^2 + K_v s + K_p} e^{-\frac{L}{c}s} \quad (25)$$

## 4 NUMERICAL ANALYSIS

In this section, in order to analyze the validity of the proposal, numerical simulations and analyses are conducted. First, for confirming the performance of the proposed method, a position control of a three-mass resonant system with communication delay is conducted. Next, we analyze variation of delay of a resonant system and communication system.

Table 1. Simulation parameters.

| Parameter     | Description                                   | Value      |
|---------------|---|------------|
| $T_s$         | Sampling time                                 | 0.1 ms     |
| $K_{tn}$      | Force coefficient                             | 3.33 N/A   |
| $M_n$         | Mass  | 0.245 kg   |
| $\frac{L}{c}$ | Propagation time of wave                      | 107 ms     |
| $T_1 + T_2$   | Communication delays (Round trip delay)       | 200 ms     |
| $\omega_1$    | First-order resonance                         | 14 rad/s   |
| $\omega_2$    | Second-order resonance                        | 42 rad/s   |
| $K_p$         | Position control gain                         | 200        |
| $K_v$         | Velocity control gain                         | 30         |
| $g_{pd}$      | Cut-off frequency of pseudo derivation        | 3000 rad/s |
| $g_{dis}$     | Cut-off frequency of disturbance observer     | 2000 rad/s |
| $g_r$         | Cut-off frequency of reflected wave rejection | 1000 rad/s |
| $g_w$         | Cut-off frequency of wave compensator         | 2000 rad/s |

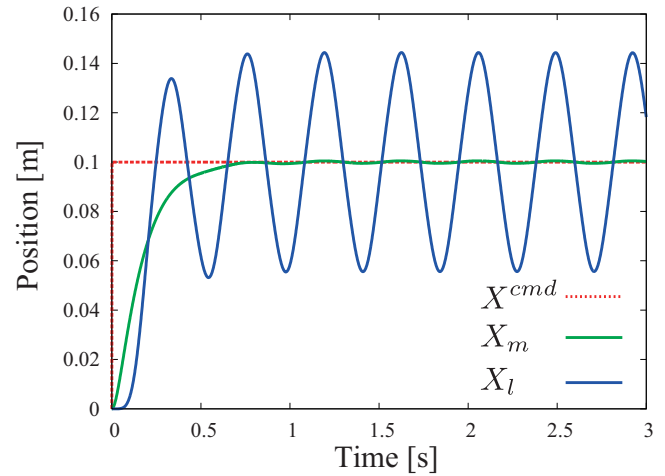

Fig. 11. Simulation results of the method with disturbance observer without communication delay.

### 4.1 Position Control

In this part, position control of a three-mass resonant system with communication delay is conducted. The simulation parameters are shown in Table 1. In this simulation, step input is used as the position command. The proposed method is compared with the method based on disturbance observer.

Firstly, for confirming the performance of the reflected wave rejection, the simulations in the case that there is

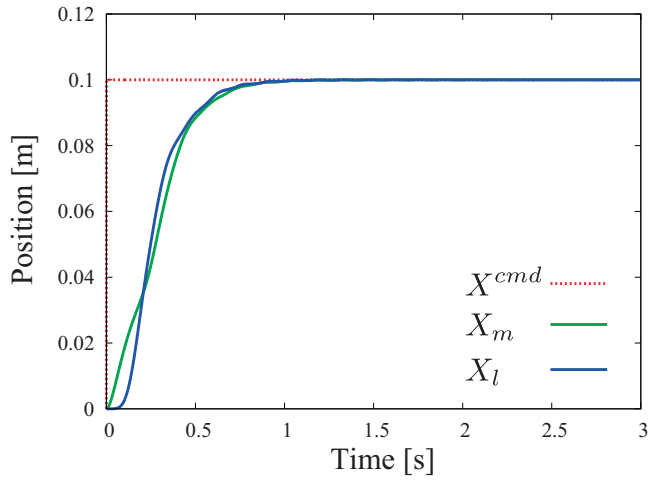

Fig. 12. Simulation results of the proposed method without communication delay.

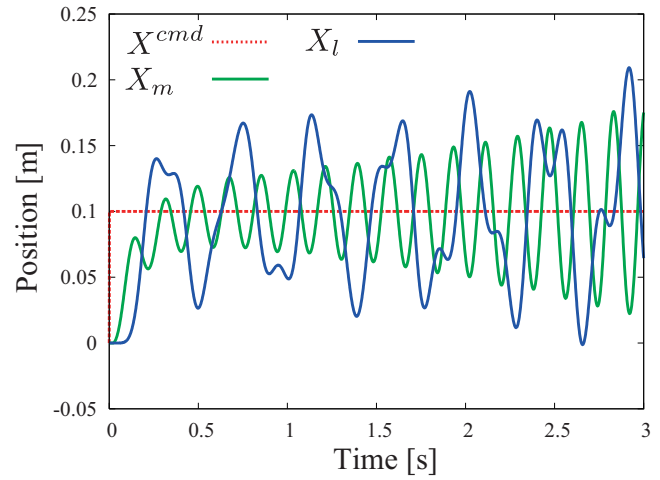

Fig. 14. Simulation results of the method with disturbance observer with communication delay.

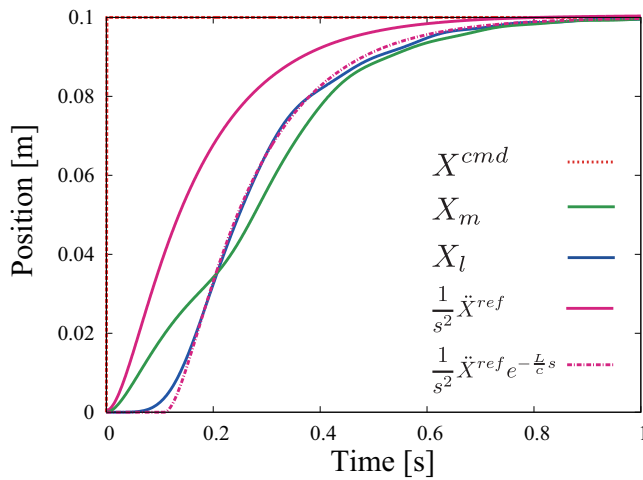

Fig. 13. Enlarged view of Fig. 12.

no time delay are conducted. The simulations results are shown in Figs. 11 and 12. From Fig. 11, it is found that vibration from the resonant system occurs on the response of load position  $X_l$ . On the other hand, from Fig. 11, it turns out that vibration caused by the resonance is well suppressed by the reflected wave rejection and wave compensator. Moreover, Fig. 13 shows the enlarged view of the proposed method without time delay shown in Fig. 12. It can be seen that response of the load position  $X_l$  corresponds the delayed position  $\frac{1}{s^2} \ddot{X}^{ref} e^{-L/cs}$ . The fact implies that the resonant system is transformed into an equivalent time-delay system whose time delay is  $\frac{L}{c}$  by the reflected wave rejection because (19) is achieved.

Next, the simulation results in the case that there is time

delay are shown in Figs. 14 and 15. From Fig. 14, time delay causes the vibration on the response of both motor and load position. On the other hand, from results of the proposed method shown in Fig. 15, vibration caused by time delay from the resonant and communication system is well suppressed. Fig. 16 shows the enlarged view of Fig. 15. From Fig. 15, It can also be seen that response of the load position  $X_l$  corresponds the delayed position  $\frac{1}{s^2} \ddot{X}^{ref} e^{-(L/c+T_1+T_2)s}$ . Moreover, wave compensator is able to suppress the effect of time delay which is sum of the time delays from the resonant and communication system.

From these results, validity of the proposed method which is composed of the reflected wave rejection and the wave compensator is verified.

#### 4.2 Variation of Delays

In this part, simulation in the case when communication delays are changed is conducted. Equivalent time delay of the resonant system shown in Table 1 is used. The other parameters equal to same value shown in Table 1.

Simulation results of the load position response when the communication delays are changed are shown in Fig. 17. In Fig. 17, sum of communication delays are changed from 0 ms to 1000 ms. From Fig. 17, it is found that the value of communication delays do not affect the transient response of the load position if cut-off frequency is set enough high value. This results implies that time-delay disturbance represented as (20) is suppressed by wave compensator.

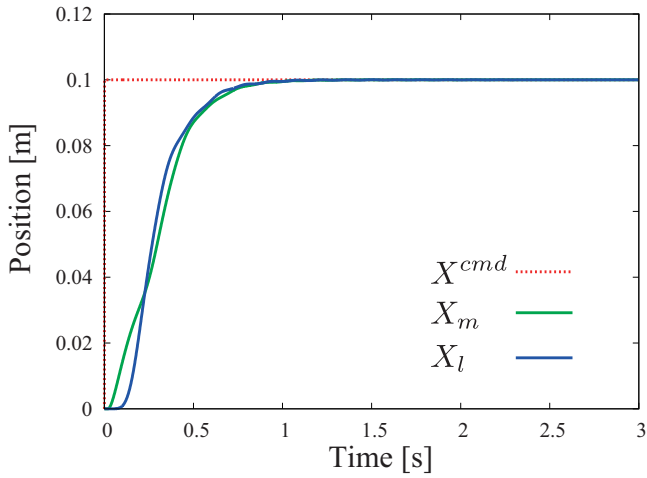

Fig. 15. Simulation results of the proposed method with communication delay.

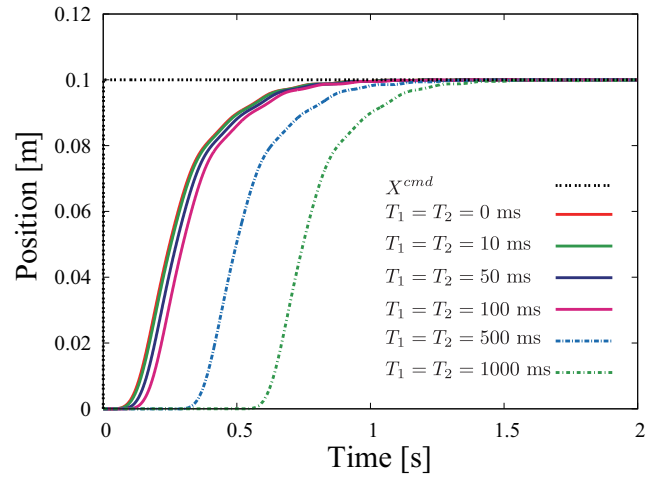

Fig. 17. Simulation results of the load position response when the communication delays are changed.

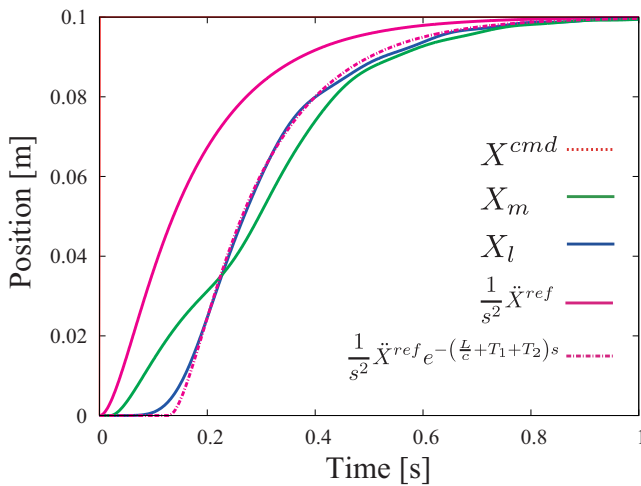

Fig. 16. Enlarged view of Fig. 15.

## 5 EXPERIMENTS

### 5.1 Experimental Setup

In order to verify the effectiveness of the proposed method, experiments of position control are conducted in a two-mass resonant system. The control software was written in C language under RTAI 3.7 (Real-Time Application Interface). The experimental setup is shown in Fig. 18. A right motor is used as load and is not controlled. On the other hand, a left motor is controlled according to the control program. Position information of each motor is obtained by linear encoders (resolution capability: 0.1  $\mu\text{m}$ ).

Experimental parameters are shown in Table 2. As roots of the characteristic equation in (25) are multiple root

Table 2. Experimental parameters.

| Parameter     | Description                                   | Value      |
|---------------|---|------------|
| $T_s$         | Sampling time                                 | 0.1 ms     |
| $K_{tn}$      | Force coefficient                             | 3.33 N/A   |
| $M_n$         | Mass  | 0.245 kg   |
| $k$           | Spring coefficient                            | 200 N/m    |
| $c$           | Propagation velocity of wave                  | 1.42 m/s   |
| $a$           | Length of a spring                            | 0.05 m     |
| $\frac{L}{c}$ | Propagation time of wave                      | 35 ms      |
| $T_1 + T_2$   | Communication delays (Round trip delay)       | 40 ms      |
| $K_p$         | Position control gain                         | 2500       |
| $K_v$         | Velocity control gain                         | 100        |
| $g_{pd}$      | Cut-off frequency of the pseudo derivation    | 2000 rad/s |
| $g_{dis}$     | Cut-off frequency of disturbance observer     | 2000 rad/s |
| $g_r$         | Cut-off frequency of reflected wave rejection | 2000 rad/s |
| $g_w$         | Cut-off frequency of wave compensator         | 1000 rad/s |

on the real axis, position and velocity gains should be set as

$$K_v = 2\sqrt{K_p} \quad (26)$$

Delay time in the reflected wave rejection is calculated by (6) and (16). And, for decreasing noise effect caused by a numerical differentiation, a pseudo differentiation represented as (27) is used for calculation of the velocities of



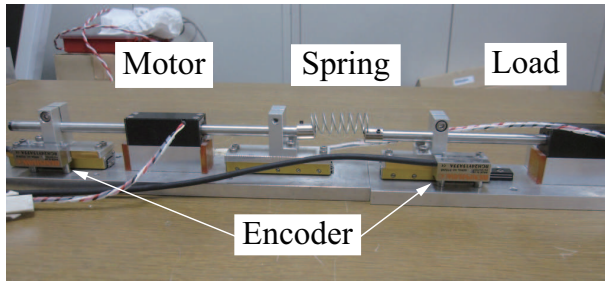

Fig. 18. Experimental setup.

the motor and the load.

$$\frac{sg_{pd}}{s + g_{pd}} \quad (27)$$

In addition, the compensation value of the reflected wave  $X_r^{cmp}$  is calculated by following equation,

$$X_r^{cmp} = \frac{sg_r}{s + g_r} \frac{sg_{pd}}{s + g_{pd}} \left( X_m - e^{-\frac{L}{c}s} X_l \right) \quad (28)$$

From (28), in order to suppress the high order vibrations, the cut-off frequency of the reflected wave rejection should be set high value. However, the cut-off frequency is limited by sampling time and noise level. Therefore, the cut-off frequency is set to high value in the limitation of actual equipment. In addition, communication delays are artificially generated in a computer.

Performance of the proposed method is compared with those of a method using PD controller with a disturbance observer and a method using a resonant ratio control and a communication disturbance observer. Each control gain is set to make the time-constants of the proposed and compared methods same. A disturbance observer and a reaction force observer in the compared methods are implemented in the remote side. In the resonant ratio control, a reaction force feedback is conducted at remote side.

## 5.2 Experimental Results

The experimental results of the PD controller with disturbance observer is shown in Fig. 19. In Fig. 19, it can be seen that the system becomes unstable because of communication delay.

The experimental results of the resonant ratio control with communication disturbance observer is shown in Fig. 20. In similar to the results of the PD controller with the disturbance observer, the system becomes unstable. The reason is that error of plant model in the communication disturbance observer makes the system unstable.

On the other hand, in results of the proposed method shown in Fig. 21, the system is kept stable and vibration

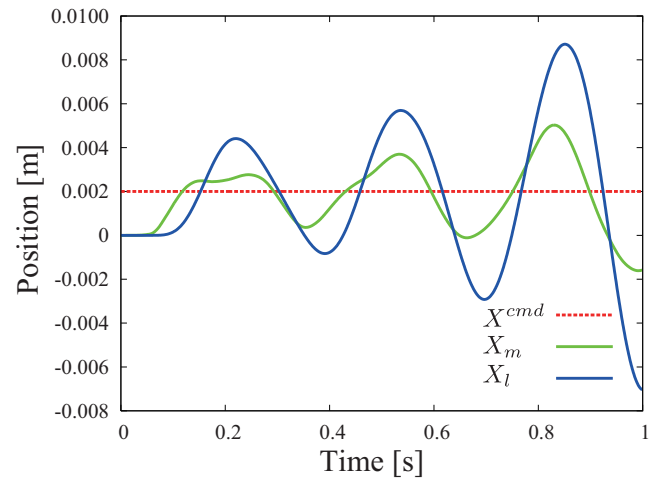

Fig. 19. Experimental results of PD controller with disturbance observer.

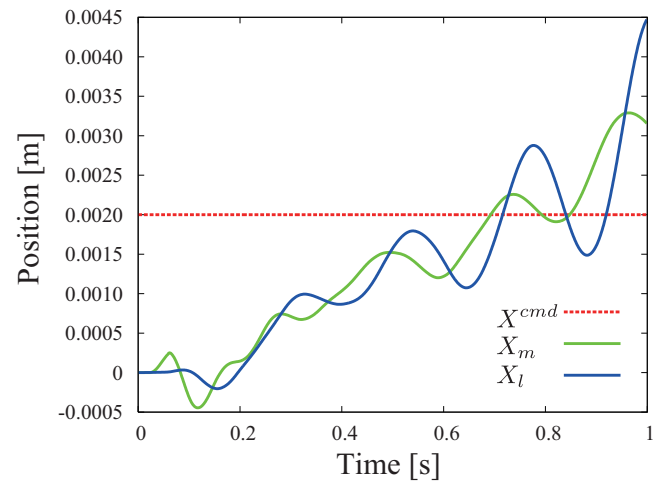

Fig. 20. Experimental results of resonant ratio control with communication disturbance observer

is well suppressed. From Fig. 21, a steady state error is observed at the load side because of the load disturbance composed of coulomb and viscous frictions.

## 6 CONCLUSIONS

This paper proposed the vibration control method based on a transfer function of wave equation. The proposed method is composed of two important structures. Firstly, a control structure to remove a reflected wave was shown. By using the reflected wave rejection, the resonant system was regarded as time-delay system. Therefore, it was possible to integrate time delay of the resonant system with the communication system. Secondly, for suppress-

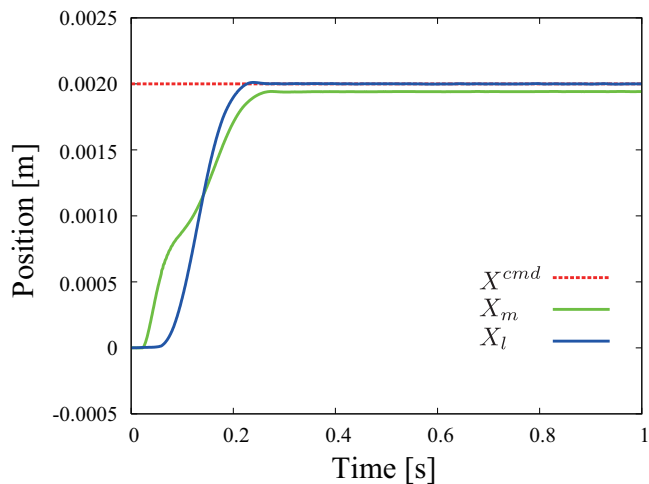

Fig. 21. Experimental results of the proposed method.

ing vibrations from the resonant system and the communication delay, a wave compensator based on CDOB was proposed. In the wave compensator, it is defined that effect of time delays from the resonant and communication system was caused by a time-delay disturbance. The wave compensator can estimate and compensate the time-delay disturbance. Therefore, by using the wave compensator, it became possible to suppress the vibrations from the resonant system and the communication delay simultaneously. Finally, the effectiveness of the proposed method was verified by simulation and experimental results.

## ACKNOWLEDGMENT

This research was partially supported by the Ministry of Internal Affairs and Communications, Strategic Information and Communications RD Promotion Programme (SCOPE), 112103003, 2011.

## REFERENCES

- [1] M. Elitas, S. Khan, A. O. Nergiz, A. Sabanovic, "Task Based Bilateral Control for Microsystems Application," in *AUTOMATIKA: Journal for Control, Measurement, Electronics, Computing and Communications*, Vol. 52, No. 2, pp. 107–117, 2011.
- [2] S. H. Song, J. K. Ji, S. K. Sul, and M. H. Park, "Torsional Vibration Suppression Control in 2-Mass System by State Feedback Speed Controller," in *Proceedings of 2nd IEEE Conference on Applications, '93-VANCOUVER*, Vol. 1, pp. 129–134, September 13–16, 1993.
- [3] S. Morimoto and Y. Takeda, "Two-Degrees-of-Freedom Speed Control of Resonant Mechanical System Based on  $H_\infty$  Control Theory," in *Transaction of IEE Japan*, Vol. 116–D, No. 1, pp. 65–70, January, 1996.
- [4] M. Hirata, K. Z. Liu, and T. Mita, "Active Vibration Control of a 2-Mass Spring System using  $\mu$ -Synthesis," in *Transaction of IEE Japan*, Vol. 114–D, No. 5, pp. 512–519, March, 1993.
- [5] I. S. M. Khalil and A. Sabanovic, "Sensorless Wave Based Control of Flexible Structure Using Actuator as a Single Platform for Estimation and Control," in *International Review of Automatic Control*, Vol. 2, No. 1, pp. 83–89, January, 2009.
- [6] H. Iwamoto and N. Tanaka, "Active Wave Feedback Control of a Flexible Beam Using Wave Filter : Theoretical Verification of Basic Properties," in *Transactions of the Japan Society of Mechanical Engineers. C*, Vol. 70, No. 689, pp. 46–53, 2004.
- [7] M. Saigo and N. Tanaka, "Torsional Vibration Suppression by Using Wave Absorbing Filter," in *Transactions of the Japan Society of Mechanical Engineers. C*, Vol. 71, No. 703, pp. 852–858, 2005.
- [8] K. Yuki, T. Murakami, and K. Ohnishi, "Vibration Control of 2-Mass Resonant System by Resonant Ratio Control," in *Proceedings of the 1993 IEEE International Conference on Industrial Electronics, Control, and Instrumentation, IECON '93-MAUI*, Vol. 3, pp. 2009–2014, November, 1993.
- [9] S. Katsura and K. Ohnishi, "Force Servoing by Flexible Manipulator Based on Resonance Ratio Control," in *IEEE Transactions on Industrial Electronics*, Vol. 54, pp. 539–547, February, 2007.
- [10] Y. Hori, H. Sawada, and C. Yeonghan, "Slow Resonance Ratio Control for Vibration Suppression and Disturbance Rejection in Torsional System," in *IEEE Transactions on Industrial Electronics*, Vol. 46, No. 1, pp. 162–168, February, 1999.
- [11] T. Murakami, F. Yu, and K. Ohnishi, "Torque Sensorless Control in Multidegree of Freedom Manipulator," in *IEEE Transactions on Industrial Elements*, Vol. 40, No. 2, pp. 259–265, April, 1993.
- [12] O. J. M. Smith, "A Controller to Overcome Dead Time," in *the International Society of Automation Journal*, Vol. 6, No. 2, pp. 28–33, February, 1959.
- [13] K. Natori and K. Ohnishi, "An Approach to Design of Feedback Systems with Time Delay," in *the 31st Annual Conference of the IEEE Industrial Electronics Society, IECON '05-RALEIGH*, pp. 1931–1936, November 6–10, 2005.
- [14] K. Natori and K. Ohnishi, "A Design Method of Communication Disturbance Observer for Time-Delay Compensation, Taking the Dynamic Property of Network Disturbance Into Account," in *IEEE Transactions on Industrial Electronics*, Vol. 55, No. 5, pp. 2152–2168, May, 2008.
- [15] K. Natori, R. Oboe, and K. Ohnishi, "Stability Analysis and Practical Design Procedure of Time Delayed Control Systems With Communication Disturbance Observer," in *IEEE Transactions on Industrial Informatics*, Vol. 4, No. 3, pp. 185–197, August, 2008.

- [16] E. Saito, S. Katsura, "Vibration Control of a Two-mass Resonant System Using Wave Compensator," in *SICE 2011 Annual Conference, SICE 2011-TOKYO*, pp. 363–368, September 13–18, 2011.
- [17] E. Saito, S. Katsura, "Vibration Control of Flexible System With Communication Delay Using Wave Compensator," in *the 12th International Workshop on Advanced Motion Control, AMC2012-SARAJEVO*, March 25–27, 2012.
- [18] K. Ohnishi, M. Shibata, and T. Murakami, "Motion Control for Advanced Mechatronics," in *IEEE/ASME Transactions on Mechatronics*, Vol. 1, No. 1, pp. 56–67, March, 1996.
- [19] S. Katsura, Y. Matsumoto, and K. Ohnishi, "Modeling of Force Sensing and Validation of Disturbance Observer for Force Control," in *IEEE Transactions on Industrial Electronics*, Vol. 54, No. 1, pp. 530–538, February, 2007.



**Eiichi Saito** received his B.E. degree in system design engineering and his M.E. degrees in integrated design engineering from Keio University, Yokohama, Japan, in 2011 and 2012. He is currently working toward the Ph.D. degree at Keio University. He received the Best Conference Paper Award from the IEEE Industrial Electronics Society in 2012. His research interests include vibration control, haptics, and time-delay compensation.



**Seiichiro Katsura** received his B.E. degree in system design engineering and his M.E. and Ph.D. degrees in integrated design engineering from Keio University, Yokohama, Japan, in 2001, 2002 and 2004, respectively. From 2003 to 2005, he was a Research Fellow of the Japan Society for the Promotion of Science. From 2005 to 2008, he worked at Nagaoka University of Technology, Nagaoka, Niigata, Japan. Since 2008, he has been at Keio University, Yokohama, Japan. His research interests include real-world haptics, human support space, systems energy conversion, and electromechanical integration systems.

human support space, systems energy conversion, and electromechanical integration systems.

Prof. Katsura received the Best Paper Award from the Institute of Electrical Engineers of Japan (IEEJ) in 2003, the Dr. Yasujiro Niwa Outstanding Paper Award in 2004, The European Power Electronics and Drives-Power Electronics and Motion Control Conference, EPE-PEMC'08 Best Paper Award in 2008, and the 4th IEEE International Conference on Human System Interaction, HSI'11 Best Paper Award in 2011.

He is a Senior Member of IEEJ, as well as a Member of the IEEE, EPE, The Society of Instrument and Control Engineers (SICE), The Japan Society of Mechanical Engineers (JSME), The Japan Society for Precision Engineering (JSPE), Robotics Society of Japan (RSJ), The Institute of Electronics, Information and Communication Engineers (IEICE), and The Japan Society of Computer Aided Surgery (JSCAS).

#### AUTHORS' ADDRESSES

**Eiichi Saito, M.Sc.**

**Assoc. Prof. Seiichiro Katsura, Ph.D.**

**Department of System Design Engineering,**

**Keio University,**

**3-14-1 Hiyoshi, Kohoku, Yokohama 223-8522, Japan**

**email: saito@katsura.sd.keio.ac.jp, katsura@sd.keio.ac.jp**

Received: 2012-07-05

Accepted: 2012-10-17