

Comparison of DoA Estimation Algorithms in SDMA System

DOI 10.7305/automatika.54-2.131
UDK 621.396.67.011.4.092:519.254
IFAC 5.8.3; 1.1

Original scientific paper

With Space Division Multiple Access (SDMA) schemes employing digital signal processing algorithms in its smart antenna systems, it is possible to improve the system capacity of modern wireless communication systems by enabling user's angular separation. Angular separation ability enhances reception in Signal-of-Interest direction and minimizes interference in Signal-of-Not-Interest direction. Direction of Arrival (DoA) algorithms are used for estimation of a number of incident plane waves on the antenna array and their incidence angles. This paper compares performance of three DoA algorithms: MUSIC, root-MUSIC and Capon applied on the uniform linear array in the presence of uncorrelated white noise. The simulation results show that MUSIC outperformed root-MUSIC and Capon in both required number of snapshots and number of array elements as well as in signal-to-noise ratio requirements.

Key words: Capon, DoA estimation, MUSIC, root-MUSIC, MVDR

Usporedba algoritama procjene smjera dolaska u sustavima prostorno raspodjeljenog višestrukog pristupa. Korištenjem digitalnih sustava obradbe signala u inteligentnim antenama za sustave prostorno raspodjeljenog višestrukog pristupa, moguće je, ostvarivanjem razlučivanja korisnika po kutu, unaprijediti ukupni kapacitet sustava suvremenih bežičnih komunikacijskih sustava. Mogućnost razdvajanja po kutu pojačava prijam u smjeru korisnog signala i minimizira smetnju iz smjerova smetajućih signala. Algoritmi procjene smjera dolaska se koriste za procjenu broja planarnih valova koji upadaju na antenski niz, te za procjenu njihovih upadnih kutova. Ovaj rad uspoređuje kakvoću tri algoritama procjene kuta upada: MUSIC, root-MUSIC i Capon, primijenjenih za uniformni antenski niz u prisustvu nekoreliranog bijelog šuma. Rezultati simulacija pokazuju da je MUSIC algoritam davao najbolje rezultate, u smislu minimalnog potrebnog broja uzoraka, minimalnog broja potrebnih elemenata niza, te u smislu minimalnih potreba odnosa signal-šum.

Ključne riječi: Capon, procjena smjera dolaska, MUSIC, root-MUSIC, MVDR

1 INTRODUCTION

In our day to day life, overwhelming amount of devices such as personal digital assistants (PDA), TV remote controls, cellular phones, satellite TV receivers and mobile computers are based on wireless communications technology. Many more new technologies are emerging, which demand more spectrum and bandwidth for faster growth. But since the electromagnetic spectrum is a limited resource, it is not possible to get new spectrum allocation without the international coordination on the global level. Therefore efficient use of existing spectrum is of prime interest as a research objective. Efficient source and channel coding as well as reduction in transmission power, transmission bandwidth or both are significantly contributing to this challenging issue. With the advances in digital techniques, the frequency efficiency can be improved by Multiple Access Technique (MAT), which improves mo-

bile users' access to the scarce resources of base station and hence improves the system's capacity [1]. By adding a new parameter of 'space' or 'angle' to the existing family of Frequency Division Multiple Access (FDMA), Time Division Multiple Access (TDMA), Code Division Multiple Access (CDMA) and Orthogonal Frequency Division Multiple Access (OFDMA) schemes, a new MAT known as 'Space Division Multiple Access' (SDMA) is established [2]. Generally, at the receiver's side, the signal received is a superposition of multipath components combined with interferers' signals, and with present noise. Thus, detection of the Signal-of-interest (SoI) is a tough task. The Smart Antenna System (SAS) embeds the antenna elements and the digital signal processing unit which enables it to form a beam to a desired direction taking into account the multipath signal components. Hence, Signal-to-Interference-and-Noise Ratio (SINR) can be improved

due to producing nulls towards the interferers in the direction of Signal-of-not-Interest (SonI) [3-5] and overall spectrum efficiency can be increased. In order to form beam in SoI direction, estimate of the number of plane waves arriving at the antenna array and the angle at which the waves are incident on antenna array is essential. The angle of wave incidence on antenna array is calculated using Direction of Arrival (DoA) estimation algorithms [3-5]. Thus the performance of SAS greatly depends on the performance of its DoA estimation algorithm.

A previous paper [4] investigated performance of the DoA algorithms MUSIC, ESPRIT and root-MUSIC on the uniform linear array in the presence of white noise. The simulation results showed to which extent the resolution of DoA techniques improves as number of snapshots, number of array elements and signal-to-noise ratio increase. In [4] mean square estimated error (MSE) was used for describing quality of DoA estimation algorithms. The simulation results showed that MUSIC algorithm was superior to the other two.

In this paper, we have investigated the performance of three very popular algorithms: Capon, MUSIC, and root-MUSIC. In our investigation, following parameters were considered: number of array elements, user spatial distribution (wide/narrow/combined angular separation), number of snapshots and Signal-to-Noise Ratio (SNR). Further, limitations and sensitivity of all algorithms to the DoA angles around direction along the antenna array are analysed.

The research and comparison of performance was limited to the special case of continuous wave (unmodulated signal), 2-dimensional model is used and the antennas used were with omnidirectional pattern (dipole like). Also we did not take mutual coupling into account.

The organisation of paper is as follows: Section 2 describes the background of what is SDMA scheme with SAS, Section 3 describes the framework for DoA estimation algorithms comparison, Section 4 describes the simulation results and is followed by conclusions in Section 5.

2 BACKGROUND ON SDMA USING SAS

As shown in Fig. 1, SDMA can be realised using SAS that generates multiple beam patterns; each beam would be assigned to one user (SoI) while producing nulls towards the interferers in the direction of Interferer (SonI), improving frequency reuse capability and increase in channel capacity. After the system downconverts the received signals to the baseband and digitizes them, it locates the SoI (user) using DoA algorithm and it continuously tracks the SoI and SonIs by dynamically changing the complex weights w_k (amplitudes and phases of the signals) using adaptive beamforming [6-8]. Each antenna system performs DoA estimation of all the signals to find SoI by calculating time

delays between antenna elements. This is done in Parameter Estimator block as shown in Fig. 1. The output of Parameter Estimator block is fed to adaptive beamforming where a digital signal processor (DSP) uses cost (error) function for calculating the optimum filter weights using adaptive algorithm (Least Mean Square (LMS)) that generates an array factor for an optimal Signal-to-Interference Ratio (SIR). Specifically, this results in an array pattern, where ideally the maximum of the pattern is placed towards the intended user (SoI) while nulling or attenuating the interfering users (SonI) [1],[3].

3 FRAMEWORK FOR DOA ESTIMATION ALGORITHMS COMPARISON

In practice we are interested in estimation of signal parameters such as code, time, frequency and direction of arrival. There are two main categories of parameter estimation techniques: spectral-based and parametric approaches. Spectral-based approaches form some spectrum-like function of the parameters of interest, e.g., DoA. Locations of distinct separated highest peaks of the function are recorded as DoA estimates. The parametric approaches require simultaneous search for all parameters of interest and therefore often results in more accurate estimates at the expense of increased computational complexity, which may limit the capability of estimating parameters in the real-time [4-5].

3.1 System Model

An Uniform Linear Array (ULA) is considered, with J number of signals of frequency f_0 arriving at K number of array elements which are equally spaced at distance d between the elements. The channel noise for all channels is modeled as mutually non-coherent narrowband noise at f_0 .

The steering vector of dimensions $K \times 1$ corresponding to DoA at some angle θ is given by a column vector:

$$\mathbf{v}(\theta) = \left[e^{(-j(m-1)2\pi d \sin(\theta)/\lambda)} \right]^T, m = 1, 2, \dots, K, \quad (1)$$

where $\lambda = c/f_0$ is the wavelength, c being the velocity of light and d is the spacing between antenna elements, set for this research to 0.5λ . The columnwise combination of all J steering vectors is called array manifold matrix \mathbf{V} of dimensions $K \times J$ given by $\mathbf{V}(\theta) = [\mathbf{v}(\theta_1) : \mathbf{v}(\theta_2) : \dots : \mathbf{v}(\theta_J)]$.

The spatial correlation (covariance) matrix for the N number of snapshots is given by:

$$\mathbf{S}_{\mathbf{x}} = \frac{1}{N} \sum_{t=1}^N \mathbf{x}(t) \mathbf{x}(t)^H, \quad (2)$$

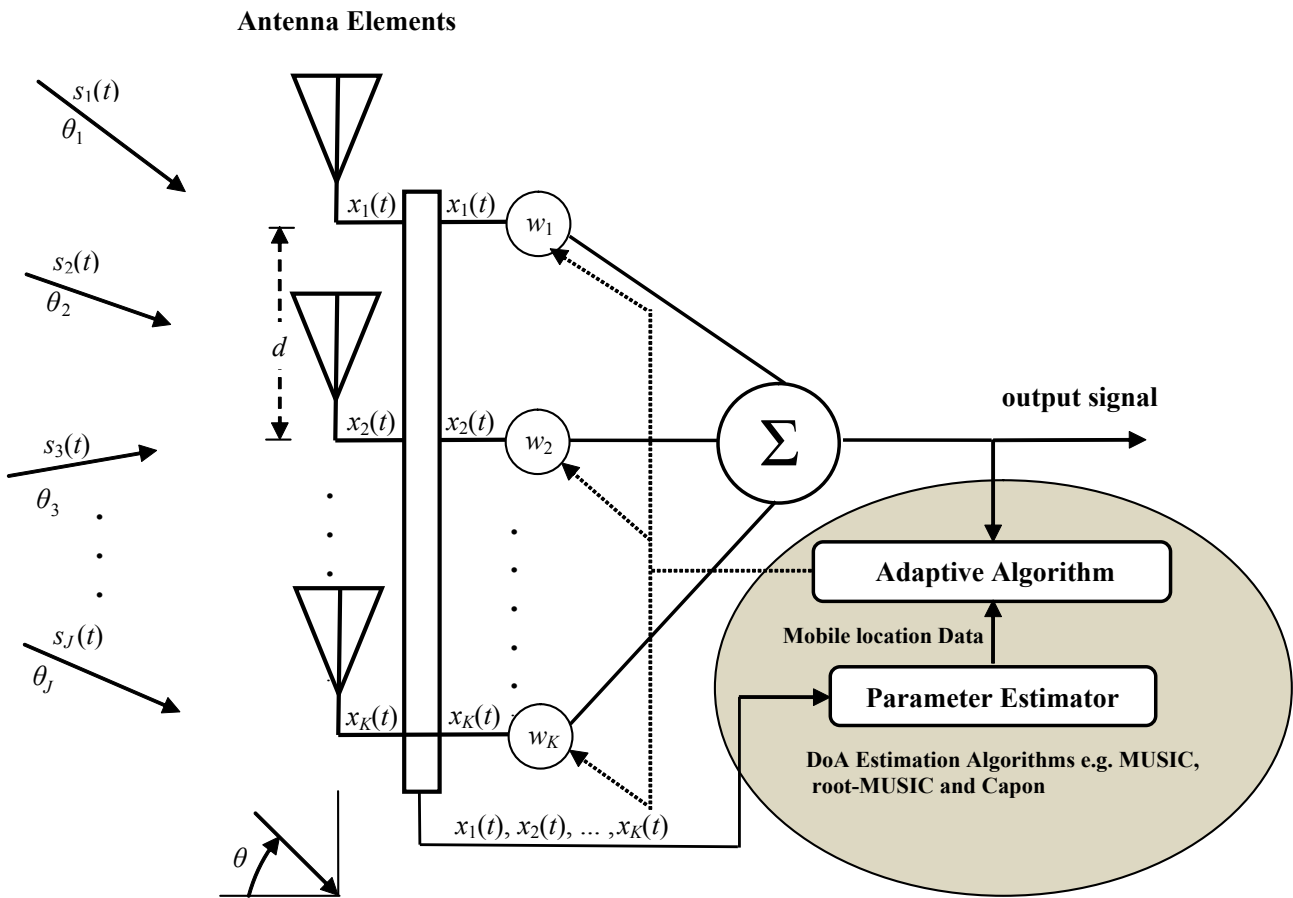

Fig. 1. SDMA employing Smart Antenna System (θ_1 to θ_J are DoAs of transmitted signals s_1 to s_J ; x_1 to x_K are antenna-specific received signals; $d = 0.5\lambda$)

where H denotes the Hermitian operator and \mathbf{x} denotes a vector of dimensions $K \times 1$ consisting of received signals x_k . Substitution of (1) into (2) results in

$$\mathbf{S}_x = \frac{1}{N} \sum_{t=1}^N \mathbf{V}(\theta) \mathbf{s}(t) \mathbf{s}(t)^H \mathbf{V}(\theta)^H + \mathbf{n}(t) \mathbf{n}(t)^H, \quad (3)$$

$$\mathbf{S}_x = \mathbf{V}(\theta) \mathbf{S}_s \mathbf{V}(\theta)^H + \sigma_w^2 \mathbf{I}, \quad (4)$$

where σ_w^2 is noise variance, \mathbf{I} is an identity matrix of size $K \times K$ and \mathbf{S}_s is received signal power matrix.

3.2 Beamforming Techniques

The principle behind beamforming technique is to "steer" the array in one direction at a time and measure output power. The steering locations that give maximum power yield DoA estimates. A number of sources will correspond to a number of peaks. The array response is steered by forming a linear combination of the sensor outputs [5],[9].

The array output is:

$$y = \sum_{i=1}^K \mathbf{w}_i^* x_i = \mathbf{w}^H \mathbf{x}(t), \quad (5)$$

where $\mathbf{w} = [w_1, w_2, \dots, w_K]^T$ is a complex weighting vector, which determines the radiation pattern. The array output samples $y(1), y(2), \dots, y(N)$ give output power as:

$$\begin{aligned} P_{o/p}(\mathbf{w}) &= \frac{1}{N} \sum_{t=1}^N |y(t)|^2 = \frac{1}{N} \sum_{t=1}^N \mathbf{w}^H \mathbf{x}(t) \mathbf{x}(t)^H \mathbf{w} \\ &= \mathbf{w}^H \mathbf{S}_x \mathbf{w}. \end{aligned} \quad (6)$$

Bartlett's [5] and Capon's methods are based on Beamforming techniques.

3.3 Capon's method

Capon's method is also called Minimum Variance Distortionless Response algorithm (MVDR). The aim is to

minimize power contributed by noise and any signals coming from other direction than desired [9-11].

$$\min_w (\mathbf{w}^H \mathbf{S}_x \mathbf{w}) \quad \text{Subject to } |\mathbf{w}^H \mathbf{v}(\theta)| = 1. \quad (7)$$

The Capon's weight vector is found to be:

$$\mathbf{w}_{\text{capon}} = \frac{\mathbf{S}_x^{-1} \mathbf{v}(\theta)}{\mathbf{v}(\theta)^H \mathbf{S}_x^{-1} \mathbf{v}(\theta)}. \quad (8)$$

Thus Capon's output spectrum is:

$$P_{\text{capon}} = \frac{1}{\mathbf{v}(\theta)^H \mathbf{S}_x^{-1} \mathbf{v}(\theta)}. \quad (9)$$

3.4 Subspace Based Methods

In Subspace based method, the observed covariance matrix is decomposed into two orthogonal spaces: signal subspace and noise subspace. The DoA estimation is calculated from any one of the subspaces. The subspace based DoA estimation algorithms MUSIC and ESPRIT provide high resolution, they are more accurate and not limited to physical size of array aperture [4][9][12].

3.5 MUSIC algorithm

MUSIC stands for **M**Ultiple **S**ignal **C**lassification, one of the high resolution subspace DoA algorithms, which gives an estimate of a number of arrived signals, hence their direction of arrival [5][9][12-16]. Estimation of DoA is performed from one of subspaces either signal or noise, assuming that noise in each channel is highly uncorrelated. This makes the covariance matrix diagonal.

Writing the spatial covariance matrix in terms of eigenvalues and eigenvectors[7-9] gives

$$\mathbf{S}_x = \sum_{i=1}^K T_i \boldsymbol{\varphi}_i \boldsymbol{\varphi}_i^H, \quad (10)$$

$$\mathbf{S}_x = \boldsymbol{\varphi} \boldsymbol{\beta} \boldsymbol{\varphi}^H, \quad (11)$$

$$\boldsymbol{\beta} = \text{diag} [T_1, T_2, \dots, T_K]. \quad (12)$$

The noise subspace eigenvalues and eigenvectors are:

$$T_i, \quad i = J+1, J+2, \dots, K, \quad (13)$$

$$\boldsymbol{\varphi}_i, \quad i = J+1, J+2, \dots, K. \quad (14)$$

The noise subspaces can be written in the form of $K \times (K - J)$ matrix:

$$\boldsymbol{\vartheta}_N = [\boldsymbol{\varphi}_{J+1}, \boldsymbol{\varphi}_{J+2}, \dots, \boldsymbol{\varphi}_K]. \quad (15)$$

Equation (15) indicates that the desired value DoA of $\theta_1, \theta_2, \dots, \theta_J$ can be found out by finding a set of vectors that span $\boldsymbol{\vartheta}_N$ and projecting $\mathbf{v}(\theta)$ onto $\boldsymbol{\vartheta}_N$ for all values of θ and evaluating the J values of θ , where the projection is zero:

$$\|\mathbf{v}_i^H \boldsymbol{\vartheta}_N\|^2 = 0, \quad i = 1, 2, \dots, J. \quad (16)$$

Thus, MUSIC Pseudospectrum is given as:

$$P_{\text{music}}(\theta) = \frac{1}{\text{abs} [\mathbf{v}(\theta)^H \boldsymbol{\vartheta}_N \boldsymbol{\vartheta}_N^H \mathbf{v}(\theta)]}. \quad (17)$$

3.6 Root-MUSIC algorithm

Root-MUSIC is the polynomial version of MUSIC. The array manifold matrix is expressed in polynomial form by evaluating at $z=e^{j\theta}$. If the eigendecomposition corresponds to the true spectral matrix, then MUSIC spectrum $P_{\text{music}}(\theta)$ becomes equivalent to the polynomial on the unit circle and peaks in the MUSIC spectrum exist as roots of polynomial that lie close to the unit circle [5], [17-19]. That is $P_{\text{music}}(z)|_{z=e^{j\theta}} = P_{\text{music}}(\theta)$. Ideally in absence of noise, the poles will lie exactly on the unit circle at the locations determined by DoA. Ultimately, we calculate the polynomial and select the J roots that are inside the unit circle. A pole of polynomial, $D(z)|_{z=z_q} = |z_q| = |\exp(j \arg(z_q))|$ will result in a peak in the MUSIC spectrum at:

$$\theta = \sin^{-1} \{ \lambda / 2\pi d \} \arg [z_q], \quad q = 1, 2, \dots, J. \quad (18)$$

3.7 ESPRIT

The ESPRIT algorithm is described here for completeness. Its acronym stands for **E**stimation of **S**ignal **P**arameter via **R**otational **I**nvariance **T**echnique. This algorithm is more robust with respect to array imperfections than MUSIC [4]. Computation complexity and storage requirements are lower than for MUSIC algorithm, as it does not involve extensive search throughout all possible steering vectors, but rather it explores the rotational invariance property in the signal subspace created by two subarrays derived from original array with a translation invariance structure.

The detailed comparison between MUSIC, root-MUSIC and ESPRIT was made in [4].

4 RESULTS

For reliable comparison between algorithms, 50 trials were run for each case and their results were averaged before the comparison. Also, standard deviation (in degrees)

of DoA estimation (also in degrees) in these 50 trials is used for presenting accuracy and deviation of DoA estimation results: the higher the deviation – the higher the unreliability of the algorithm for given conditions. The MUSIC, Capon and root-MUSIC techniques for DoA estimations were simulated using MATLAB.

The simulations were run for three different sets of environment: one with wide angular separation $E_W = \{0^\circ, 25^\circ, 55^\circ\}$, one with narrow angular separation $E_N = \{-5^\circ, 10^\circ, 20^\circ\}$ and the last one with combination of wide and narrow separations $E_C = \{0^\circ, 10^\circ, 15^\circ, 40^\circ\}$. Furthermore, accuracy in the case of DoA close to 90° (alongside the ULA) is considered. For analysing the performance of these algorithms, regarding impact of number of array elements, number of snapshots and SNR, simulation parameters were set as follows:

1. **Impact of number of array elements:** at SNR of 10 dB 200 snapshots for environment E_W and E_N were considered.
2. **Impact of number of snapshots:** array of 10 elements at SNR of 10 dB for environment E_N was considered.
3. **Impact of SNR:** 16 element arrays with 200 snapshots for environment E_C were considered.
4. **Performance with DoAs around 90° :** 16 element arrays with 200 snapshots and SNR of 10 dB were considered, with environments containing one DoA around 90° .

4.1 Impact of number of array elements

Table 1 and Table 2 show the performance of algorithms for different number of array elements. Figure 2 and Fig. 3 show standard deviation of DoAs for 50 runs as a measure of error of algorithms. Root-MUSIC showed significant down performance comparing to MUSIC and Capon in case of wide angular separation.

While MUSIC and Capon errors are less than 1° already for 5 element array and above, root-MUSIC error is still above 40° coming down to 17° for 6 element array and reaching below 1° only for 7 element array and above.

Further the spectrum for wide angular separation and narrow angular separation has been plotted for Capon and MUSIC. As shown in Fig. 4 for wide angular separation, both Capon and MUSIC algorithms accurately detect DoA at $\{0^\circ, 25^\circ, 55^\circ\}$ and sharp peaks in the spectrum for estimated DoAs are visible.

Figure 3 shows that for narrow angular separation case with 5 element array, all three algorithms still had significant DoA estimation errors (around 33° , 32° and 42° for

Table 1. Effect of number of array elements on performance of algorithms [SNR=10 dB, snapshots=200] in case of wide angular separation $E_W = \{0^\circ, 25^\circ, 55^\circ\}$

Array Size	Mean DoA estimation (in deg.) out of 50 runs		
	MUSIC	Capon	Root-MUSIC
5	0	-0.5	-60.09
	25	25.8	7.65
	55.9	56	39.29
6	0	-0.1	-28.61
	25	24.9	-0.39
	55	54.9	55.90
7	0.1	0.1	-0.09
	24.9	24.9	24.54
	55	54.9	55.99
8	0.1	0	0.14
	24.9	25	25.33
	54.8	54.8	53.66
9	0	0.1	-0.06
	24.9	25.1	24.89
	55.2	55.1	55.01
10	0	0	-0.01
	25	25	25.04
	54.9	54.9	54.84
11	-0.1	-0.1	-0.02
	25	25	25.02
	55	54.9	55.04
12	-0.1	0.1	-0.06
	25	25	25.01
	55	55	54.84
13	0	0	0.01
	25	25	25.27
	55	55	54.97
14	0	0	-0.01
	25	25	25.05
	55	55	54.99
15	0	-0.1	0.02
	25	25	24.98
	55	55.1	55.06
16	0	0	-0.02
	25	25	24.96
	55	55	54.98

MUSIC, Capon and root-MUSIC algorithms respectively). MUSIC algorithm proved again to be more robust than the other two, having its error reduced to below 1° already for 6 element array case.

Capon algorithm turned out to be the most sensitive to reduction in angular separation having an error of less than 1° only at 9 elements array and above, root-MUSIC sensitivity to angular separation is higher than for MUSIC algorithm, but better than for Capon algorithm.

For case of narrow angular separation, Fig. 5 illustrates how for 16 element arrays both MUSIC and Capon spectra easily enable detection of all three DoAs.

4.2 Impact of number of snapshots

Figure 6 shows the performance of algorithms as a function of snapshots for narrower angular separation. It gives standard deviation of DoAs for 50 runs as a measure of error of algorithms. Below 40 snapshots all three

Table 2. Effect of number of array elements on performance of algorithms [SNR=10 dB, snapshots=200] in case of narrow angular separation $E_N = \{-5^\circ, 10^\circ, 20^\circ\}$

Array Size	Mean DoA estimation (in deg.) out of 50 runs		
	MUSIC	Capon	Root-MUSIC
5	-58.3 -3.9 10.7	-53.9 -1.9 12.9	-34.47 3.78 69.07
6	-3.9 9.9 19.9	-38.3 -2.3 13.2	-29.91 4.97 46.05
7	-5 9.7 20	-4.1 12.1 50	-5.15 15.22 39.56
8	-4.8 10.2 20.3	-26 -5 11	-5.15 10.21 20.20
9	-4.9 9.9 20	-5.2 10.5 19.1	-4.98 10.09 20.16
10	-4.9 9.9 19.9	-5.1 10.2 19.6	-5.02 9.98 19.90
11	-5 10 20	-5 10.2 19.8	-4.9 10.07 20.13
12	-4.9 10 19.9	-4.9 10 19.8	-5.02 9.87 20.09
13	-5 10 20	-5 10 20	-4.99 10.04 19.92
14	-5 10 19.9	-5.1 10 19.9	-5.02 9.98 19.85
15	-5 10 19.9	-5 10 20	-5.08 10.04 20.01
16	-5 10 19.9	-5 10 19.9	-4.99 10.02 19.91

algorithms performed poorly. For snapshots of 10, Capon gives error as 25° , root-MUSIC nearly 23° and MUSIC 11° . This error for all three algorithms starts decreasing gradually to 10° for snapshots of 30 and to 1° at 50 snapshots.

From 50 snapshots onwards all three algorithms converge to the correct value having an error of less than 1° . In this region MUSIC algorithm performed slightly better than the other two.

As shown in Table 3, up to 40 snapshots all algorithms down-perform and from 50 snapshots onwards all three algorithms perform well, having an error around 1° . In this region MUSIC algorithm performed slightly better than the other two.

4.3 Impact of SNR

The comparison of Capon and MUSIC algorithms' performance as a function of SNR value for E_C environ-

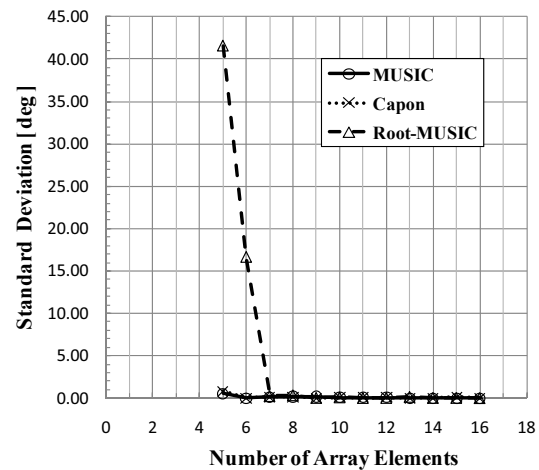

Fig. 2. Effect of varying number of array elements on performance of algorithms [SNR=10 dB, snapshots=200] in case of wide angular separation $E_W = \{0^\circ, 25^\circ, 55^\circ\}$

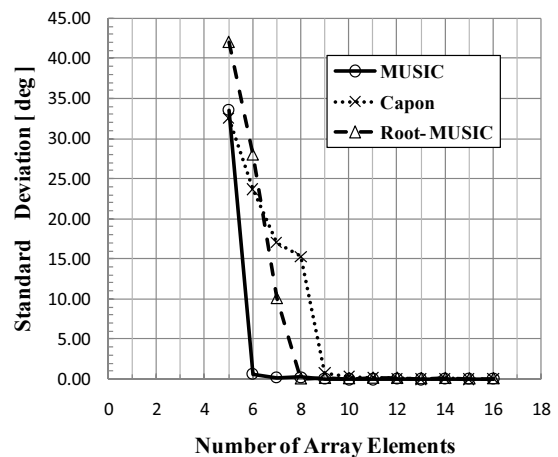

Fig. 3. Effect of varying number of array elements on performance of algorithms [SNR=10 dB, snapshots=200] in case of narrow angular separation $E_N = \{-5^\circ, 10^\circ, 20^\circ\}$

ment is given by plotting their spectra (figures 7 and 8). The analysis was performed using environment E_C where one separation was only 5° (other separations being 10° and 25°). In good SNR conditions like 10 dB and 0 dB, Capon has good resolution capability to estimate DoA at $\{0^\circ, 10^\circ, 15^\circ, 40^\circ\}$. However, as SNR value decreases, peaks in the spectrum start to disappear and hence decreases resolution capability of Capon for closely spaced signals like DoAs at 10° and 15° . From SNR of -6 dB onwards the peak related to DoA at 15° starts disappearing.

The performance of MUSIC algorithm as a function of SNR value is shown in Fig. 8 by plotting its spectrum using also environment E_C . In good SNR conditions like 10 dB

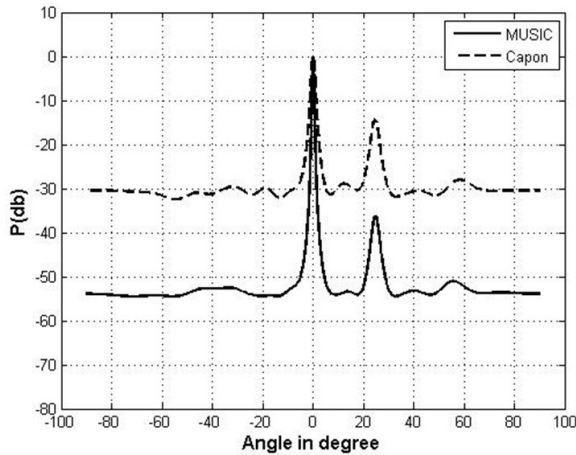

Fig. 4. Capon and MUSIC spectrum [SNR =10 dB, snapshots=200, 16 element arrays and in case of wide angular separation $E_W = \{0^\circ, 25^\circ, 55^\circ\}$

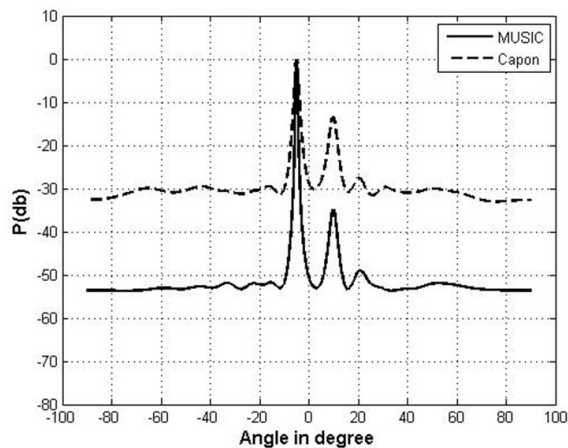

Fig. 5. Capon and MUSIC spectrum [SNR =10 dB, snapshots=200, 16 element arrays in case of narrow angular separation $E_N = \{-5^\circ, 10^\circ, 20^\circ\}$

and 0 dB, MUSIC has good resolution capability to estimate DoA at $\{0^\circ, 10^\circ, 15^\circ, 40^\circ\}$. As SNR value decreases, peaks in spectrum start to disappear and hence decreases resolution capability of MUSIC for closely spaced signals like 10° and 15° . But this effect of vanishing peak related to DoA at 15° is much less severe compared to Capon's even for SNR of -6 dB.

Thorough comparison of all three algorithms performance for different values of SNR in case of EC environment is given in Table 4.

Figure 9 gives the same comparison from the perspective of standard deviation of results. It visualises the fact that for environment E_C where one separation was only

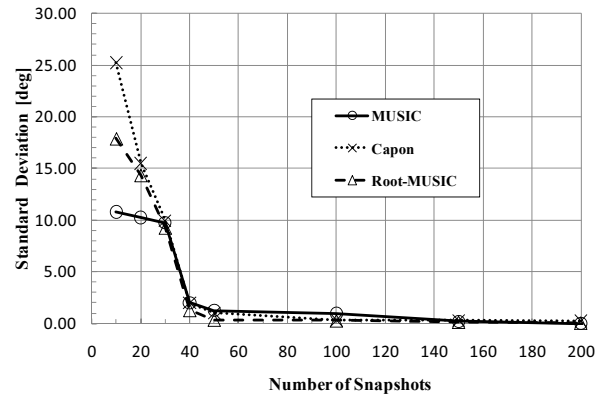

Fig. 6. Effect of varying snapshots on performance of algorithms [SNR =10 dB, array elements=10] in case of narrow angular separation $E_N = \{-5^\circ, 10^\circ, 20^\circ\}$

Table 3. Effect of varying number of snapshots on the performance of algorithm [array element=10, SNR=10 dB] in case of narrow angular separation $E_N = \{-5^\circ, 10^\circ, 20^\circ\}$

Snapshots	Mean DoA estimation (in deg.) out of 50 runs		
	MUSIC	Capon	Root-MUSIC
10	-37.4	-47.3	-36.57
	-6.5	7.5	11.41
	9.2	12.7	19.79
20	-6.6	-20.6	9.19
	9.3	-5.1	20.49
	38.9	9.5	38.74
30	-5.2	7.5	-20.73
	8.7	9.1	9.12
	36.3	37.8	20.39
40	-6.2	-6.2	-3.19
	9.3	8.8	7.78
	23.3	22.7	20.36
50	-6.1	-5.9	-4.46
	9.9	9.7	9.41
	22.4	21.7	20.01
100	-5.9	-5.7	-4.87
	9.7	9.7	10.14
	21.6	20.3	19.58
150	-5.1	-5.4	-5.01
	9.9	10	9.85
	20.3	19.8	20.16
200	-5	-5.1	-5.02
	10	10.2	9.97
	20	19.6	19.89
500	-5	-5	-5.03
	10	10	9.95
	20	20	20.02
700	-5	-5	-5.07
	10	10	9.93
	20	20	19.9

5° , Capon performs poorly below 10 dB of SNR. Sensitivity of Capon towards narrower angular separation could be observed already by comparing Fig. 2 with Fig. 3. Root-MUSIC estimation's standard deviation is higher than its MUSIC algorithm counterpart, but their performance aligns to satisfactory standard deviation of less than 1°

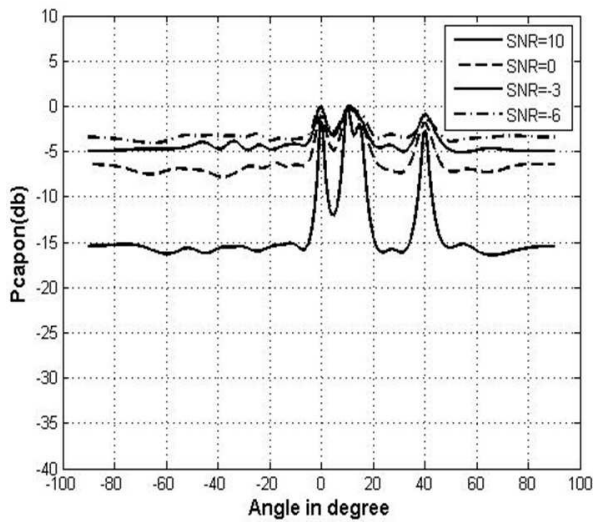

Fig. 7. Capon spectrum for varying SNR value [snapshots=200, array elements=16] in case of combination of wide and narrow angular separations $E_C = \{0^\circ, 10^\circ, 15^\circ, 40^\circ\}$

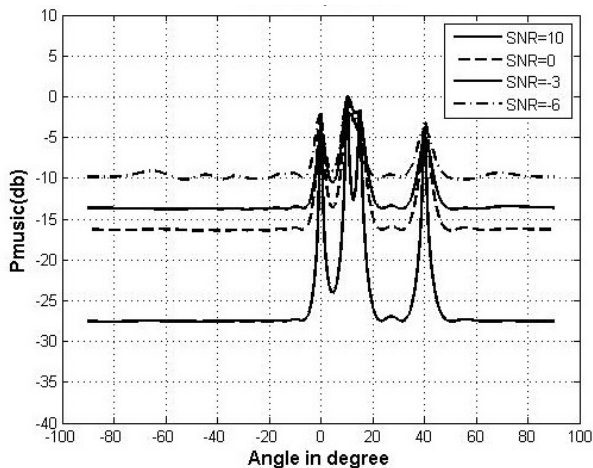

Fig. 8. MUSIC Spectrum for varying SNR value [snapshots=200, array elements=16] in case of combination of wide and narrow angular separations $E_C = \{0^\circ, 10^\circ, 15^\circ, 40^\circ\}$

from -6 dB upwards.

4.4 Performance with DoAs around 90°

Performance of all algorithms for DoAs around 90° is analysed for case of wide angular separation (Fig. 10, Fig. 11 and Fig. 12).

Figure 10 reveals that for DoA at 90° the algorithms fail to detect it due to appearance of false spectrum at negative 90° direction (180° flipping). Figure 11 reveals that

Table 4. Effect of varying SNR on algorithms [snapshots=200, array elements=16] in case of combination of wide and narrow angular separations $E_C = \{0^\circ, 10^\circ, 15^\circ, 40^\circ\}$

SNR(dB)	Mean DoA estimation (in deg.) out of 50 runs		
	MUSIC	Capon	Root-MUSIC
20	0	0	0
	10	10	9.99
	15	14.9	15
	40	40	39.98
10	0	-30.8	-0.01
	10	-0.1	10.05
	15	10.2	15.07
	40	40.1	40.01
0	0	-30.8	-0.15
	9.9	-0.2	10.08
	14.8	10.6	14.24
	40	40.1	40.18
-3	-0.1	-30.9	-0.2
	10	0.3	10.44
	14.8	10.7	14.83
	40.2	40.1	39.9
-5	-0.1	-30.9	-0.3
	10.6	-0.3	9.5
	15.1	10.7	14.1
	40.3	40	39.9
-6	-0.1	-30.9	-0.34
	10.8	-0.3	9.71
	15.3	10.7	14.16
	40.5	40	40.16
-10	-0.5	-30.9	-12.57
	10.5	-0.4	-0.42
	20	10.4	10.28
	40.8	39.8	40.55
-15	-12	-30.9	-13.75
	-8.2	-0.4	-2.9
	-0.6	10.4	11.52
	8.8	39.8	45

for DoA at 86.5°, even though flipping is still observed in the spectrum, all the algorithms detect DOAs correctly. Detailed analysis at what extent algorithms can detect DoAs correctly near 90° is validated in Fig. 12 in the form of DoA detection percentage while varying DoA from 85.5° to 90°. For that purpose simulations were run for 100 times and the percentage of correct detection was calculated.

Figure 12 reveals that all algorithms detect the DoA correctly in 100% of cases for DoAs at 85.5° and 86°. For degrees closer to 90° there is degradation in correct DoA detection and likelihood for 180° flip in the result increases. For DoAs from 88.5° to 90° all the algorithms fail to detect correctly, since correct detection rate is around 50%, i.e. as random as flipping the coin.

5 CONCLUSIONS

The paper gives thorough analysis framework for comparison between DoA estimation algorithms. It was illustrated on performance comparison between DoA estimation algorithms MUSIC, root-MUSIC and Capon. Com-

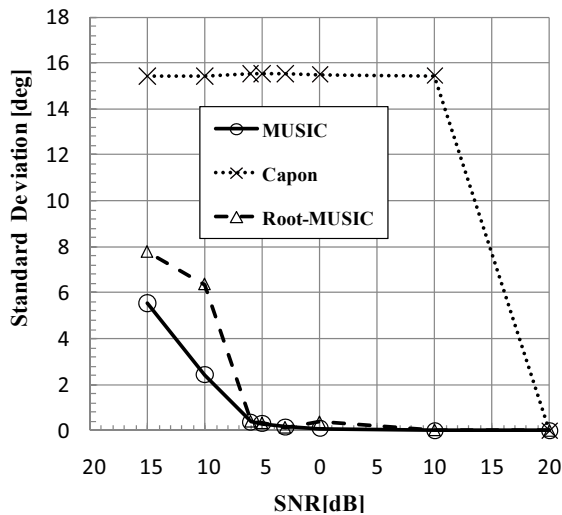

Fig. 9. Effect of Varying SNR on algorithms [snapshots=200, array elements=16] in case of combination of wide and narrow angular separations $E_C = \{0^\circ, 10^\circ, 15^\circ, 40^\circ\}$

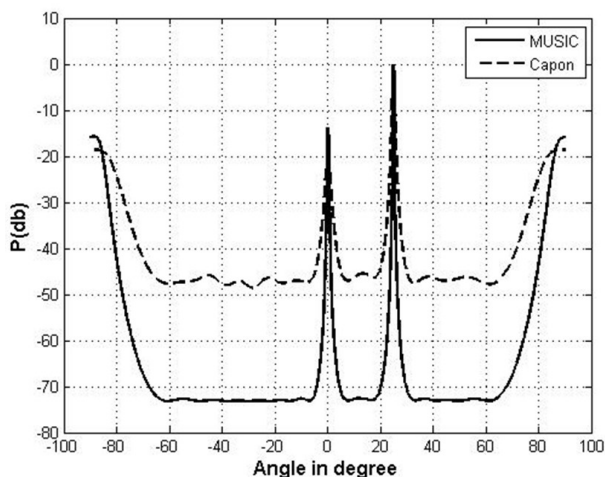

Fig. 10. Capon and MUSIC spectrum [SNR = 10 dB, snapshots=200, 16 element arrays] in case of wide angular separation $E_W = \{0^\circ, 25^\circ, 90^\circ\}$

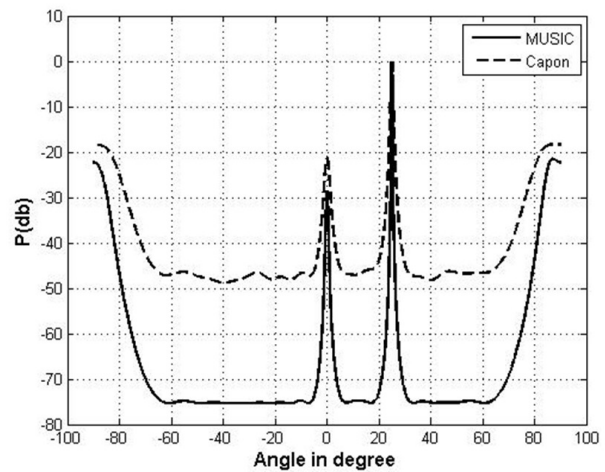

Fig. 11. Capon and MUSIC spectrum [SNR = 10 dB, snapshots=200, 16 element arrays] in case of wide angular separation $E_N = \{0^\circ, 25^\circ, 86.5^\circ\}$

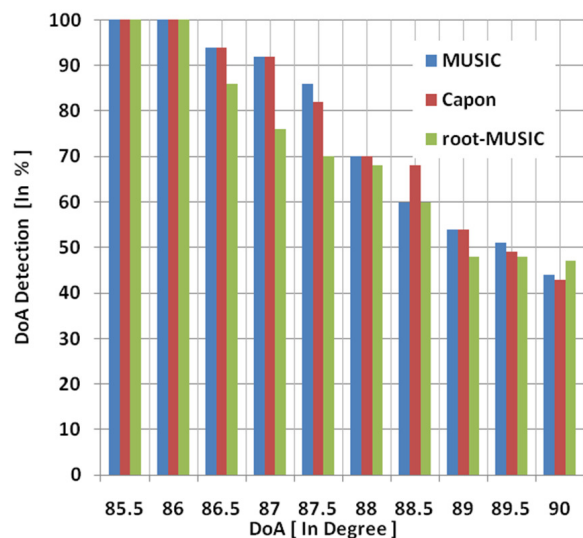

Fig. 12. Correct DoA detection [in %] for DoAs from 85.5° to 90° for MUSIC, Capon and root-MUSIC [SNR = 10 dB, snapshots=200, 16 element arrays]

parison included impact of number of snapshots, SNR, number of antenna array elements and performance comparison in the presence of wide, narrow and combined wide and narrow angular separation. Also, performance comparison for DoAs close to direction along the antenna array was given. As expected, performance improvement was observed with increasing number of array elements, increasing angular separation between the signals and with increasing SNR for all three algorithms. MUSIC algorithm showed superior performance by all criteria of comparison

(SNR level, number of elements, number of snapshots) and in all environment conditions (narrow, wide and combined angular separation). When DoAs are close to the direction along the array, all three algorithms are prone to flip the result for 180° with similar likelihood. Incidence of this flipping was 0% at 86° , rising to incidence of around 50% for angles of 88.5° and above. The results presented offer both framework for DoA algorithms' comparison and some hints about qualitative difference between Capon's MUSIC and root-MUSIC algorithms.

REFERENCES

- [1] K-C. Chen and R. Prasad, "Cognitive Radio Networks," John Wiley & Sons Ltd, 2009.
- [2] J. Litva and L. Titus, Digital Beamforming in Wireless Communication, Artech House Boston-London, 1996.
- [3] C. Balanis, Antenna Theory, Analysis and Design, 3rd edition, John Wiley and Sons, Hoboken, New Jersey, 2005.
- [4] T. Dhope, D. Simunic and M. Djurek, "Application of DOA Estimation Algorithms in Smart Antenna Systems," Studies in informatics and Control, vol.19, Issue 4, pp.445-452, Dec. 2010.
- [5] H. Trees, Optimum Array Processing, Detection, Estimation and Modulation, Part IV, John Wiley and Sons, New York, 2002.
- [6] A.Kisliansky and R. Shavit, "Direction of Arrival Estimation in the Presence of Noise Coupling in Antenna Arrays," *IEEE transaction on Antennas and Propagation*, vol. 55, no. 7, pp. 1940-1947, July 2007.
- [7] J. J. Blanz, A.Papathanassiou, M. Haardt, I.Furio and P.W.Baler. "Smart Antennas for Combined DoA and Joint Channel Estimation in Time-Slotted CDMA Mobile Radio Systems with Joint Detection," *IEEE Transactions on Vehicular Technology*, vol.49, no.2, pp. 293-305, Mar. 2000.
- [8] W.G. Diab, H. M. Elkamchouchi, "A Deterministic real-Time DoA-Based Smart Antenna Processor," *The 18th Annual IEEE International Symposium on Personal, Indoor and Mobile Radio Communications (PIMRC'07)*, pp.1-5, Sept. 2007
- [9] R.J. Weber and Y. Huang, "Analysis for Capon and MUSIC DoA Estimation Algorithms," *Antennas and Propagation Society International Symposium, 2009. APSURSI '09*, pp. 1-4, June 2009.
- [10] M. Jalali, M. Moghaddasi and A. Habibzadeh, "Comparing accuracy for ML, MUSIC, ROOT-MUSIC and spatially smoothed algorithms for 2 users," *Microwave Symposium (MMS), 2009 Mediterranean IEEE conference*, pp. 1-5, Nov. 2009.
- [11] S.W. Varade and K.D.Kulat, "Robust Algorithms for DoA Estimation and Adaptive Beamforming for Smart Antenna Application," *2nd international conference on Emerging Trends in Engineering and Technology (ICETET), 2009*, pp. 1195-1200, Dec.2009.
- [12] F.A Leon De and S.J.J Marciano, "Application of MUSIC, ESPRIT and SAGE Algorithms for Narrowband Signal Detection and Localization," *TENCON, IEEE Region 10 Conference*, pp. 1-4, Nov. 2006.
- [13] W.X.Sheng,J.Zhou,D.G.Fang and Y.C. Gu, "Super Resolution DoA Estimation in Switched Beam Smart Antenna, Antennas," *Propagation and EM Theory, 2000. Proceedings. ISAPE 5th International Symposium*, pp. 603-606, 2000.
- [14] A. Abdallah, S.A.Chabine, M. Rammal, G.Neveux,P. Vaudont, M. Campovecchio, "A Smart Antenna Simulation for (DoA) Estimation Using MUSIC and ESPRIT Algorithms," *23rd National Radio science conference (NRSC 2006)*, pp.1-10, Mar. 2006.
- [15] F. A. de Leon, J. Joseph and S. Marciano, "Application of MUSIC, ESPRIT and SAGE Algorithms for Narrowband Signal Detection and Localization", *TENCON 2006*, pp. 1-4, Nov.2006.
- [16] A. Kangas,P. Stoica and T. Soderstrom, "Finite sample and modelling error effects on ESPRIT and MUSIC direction estimators," *IEE Proc.-Radar, Sonar Navig.*, Vol. 141, No. 5, pp. 249-255, Oct. 1994.
- [17] B.D. Rao and K.V.S. Hari, "Performance analysis of ROOT-MUSIC," *IEEE Transactions on Acoustics, Speech and Signal Processing*, Vol. 37, pp. 1939-1949, Dec. 1989.
- [18] M.Pesavento, A. B. Gershman and M.Haardt "Unitary Root-MUSIC with a Real-Valued Eigendecomposition: A Theoretical and Experimental Performance Study," *IEEE transaction on Signal Processing*, vol. 48, no. 5, pp. 1306-1314, May 2000.
- [19] Qi Cheng, "Choice of Root in Root-MUSIC for OFDM Carrier Frequency Offset Estimation," *2005 Asia-Pacific Conference on Communications, Perth, Western Australia*, pp. 534-536, Oct. 2005.



Tanuja Satish Dhope (Shendkar) graduated Electronics and Telecommunication engineering at Cummins College of Engineering, University of Pune in 1999. She received Master degree in Electronics Engineering from Walchand college, Sangli, Shivaji University in 2007. Currently she is pursuing her Ph.D in wireless communication at University of Zagreb, Croatia. Her research focus is on cognitive radio network optimization with spectrum sensing algorithms, radio channel modelling for cognitive radio, cooperative spectrum sensing, Direction of arrival (DoA) Estimation algorithms in Cognitive Radio and in SDMA. She published 13 scientific papers in journals and conference proceedings.



Dina Šimunić is a full professor at University of Zagreb, Faculty of Electrical Engineering and Computing in Zagreb, Croatia. She graduated in 1995 from University of Technology in Graz, Austria. In 1997 she was a visiting professor in "Wandel & Goltermann Research Laboratory" in Germany, as well as in "Motorola Inc", Florida Corporate Electromagnetics Laboratory, USA, where she worked on measurement techniques, later on applied in IEEE Standard.

In 2003 she was a collaborator of USA FDA on scientific project of medical interference. Dr. Simunic is a IEEE Senior Member, and acts as a reviewer of IEEE Transactions on Microwave Theory and Techniques and on Biomedical Engineering and Bioelectromagnetics, journal JOSE and as a reviewer of many papers on various scientific conferences (e.g., IEEE on Electromagnetic Compatibility). She was a reviewer of Belgian and Dutch Government scientific projects, of the EU FP programs, as well as of COST-ICT and COST-TDP actions. She was acting as a main organizer of the data base in World Health Organization, for the service of International EMF Project from 2000 to 2009. From 1997 to 2000 she acted as a vice-chair of COST 244: "Biomedical Effects of Electromagnetic Fields". From 2001 to 2004 she served as vice chair of Croatian Council of Telecommunications. In 2006 she is elected the first time and re-confirmed in 2010 as vice-chair of COST Domain Committee on Information and Communication Technologies (ICT). She is one of the proposer as well as a member of COST Trans-domain Committee. She is organizer of many workshops, symposia and round tables, as well as of special sessions (e.g., on telemedicine and on intelligent transport systems during Wireless Vitae, Aalborg, Denmark in 2009). She has held numerous invited lectures, among others at ETH Zuerich, Switzerland in 1996 and US Air Force, Brooks, USA in 1997). She is author or co-author of approximately 100 publications in various journals and books, as well as her student text for wireless communications, entitled: "Microwave Communications Basics". She is co-editor of the book "Towards Green ICT", published in 2010. She is also editor-in-chief of the "Journal of Green Engineering". Her research work comprises electromagnetic fields dosimetry, wireless communications theory and its various applications (e.g., in intelligent transport systems, body area networks, crisis management, security, green communications). She serves as Chair of the "Standards in Telecommunications" at Croatian Standardization Institute. She serves as a member of the core group of Erasmus Mundus "Mobility for Life".



Radovan Zentner graduated electrical engineering at University of Zagreb in 1994. Since 1995 he served as research assistant at University of Zagreb where he also received his Ph. D. in 2002 (with honours). His research focus is on radio channel modelling for MIMO systems, broadband microstrip antennas and arrays, multiple antenna schemes for wireless communications and heuristic optimisation techniques (genetic algorithms). He published more than 30 scientific papers in journals and conference proceedings.

He participated in several European Union funded projects in antennas (COST 260, COST 284) and wireless communications (COST 273, COST 2100). Since 2011, he is an appointed management committee member of COST IC1004 project: "Cooperative Radio Communications for Green Smart Environments". He holds the assistant professor position at University of Zagreb Faculty of Electrical Engineering and Computing. He is a member of IEEE, and has served as Joint AP-MTT Chapter Chair of Croatia Section. Currently, he serves as AP Chapter Chair of Croatia Section.

AUTHORS' ADDRESSES

Tanuja S. Dhope, M.Sc.

Prof. Dina Šimunić, Ph.D.

Asst. Prof. Radovan Zentner, Ph.D.

**Department for Wireless Communications,
Faculty of Electrical Engineering and Computing,
University of Zagreb,**

Unska 3, HR-10000, Zagreb, Croatia

**email: tanuja_dhope@yahoo.com, dina.simunic@fer.hr,
radovan.zentner@fer.hr**

Received: 2011-11-22

Accepted: 2012-05-28