Katarina JERBIĆ PERCAN

PRAPOVIJESNA KERAMIKA IZ PEĆINE JAČMICE

PREHISTORIC POTTERY FROM THE JAČMICA CAVE

Katarina Jerbić Percan
Arheološki muzej Istre, Carrarina 3, 52100 Pula
katarina.jerbic@gmail.com

Katarina Jerbić Percan
Archaeological Museum of Istria, Carrarina 3, 52100 Pula
katarina.jerbic@gmail.com

UDK 903.2.02:551.144](497.5-3 Istra)“634/637”
Izvorni znanstveni članak
Primitljeno: 27.7.2012.
Odobreno: 3.9.2012.

UDC 903.2.02:551.144](497.5-3 Istra)“634/637”
Original scientific paper
Received: July 27, 2012
Approved: September 3, 2012

Pećina Jačmica jedno je od mnogih prapovijesnih nalazišta u Istri. Kao arheološko nalazište prvi je spominje arheolog Alberto Puschi, koji se u 19. stoljeću bavio istraživanjem ove i još nekoliko obližnjih pećina. U razdoblju od 19. srpnja do 5. kolovoza 2004. godine u Jačmici je provedeno arheološko istraživanje, kao dio međunarodnog projekta “Paleolitička i mezolitička nalazišta sjevernog Jadrana”. U ovom radu predstavljena je keramika koja je pronađena tijekom tog istraživanja. Od prepoznatljivih prapovijesnih grupa u pećini su prisutni ulomci impresso, vlaške, danilske i nakovanske keramike te brončanodobne keramike. Vrlo zanimljiv nalaz predstavlja ulomak keramičke pintadere.

The Jačmica cave is but one of the many prehistoric sites in Istria. Alberto Puschi, the archaeologist, was the first to mention it within the context of an archaeological site. He explored this cave and a few nearby ones in the 19th century. An archaeological excavation was staged at Jačmica in the period from July 19 to August 5, 2004, as part of an international archaeological project titled “Paleolithic and Mesolithic Sites in the Northern Adriatic”. The pottery that was discovered in the course of those excavations is presented in this work. From recognizable prehistoric groups, fragments of impresso, Vlačka, Danilo and Nakovana pottery were unearthed in the cave, and there was Bronze Age pottery as well. A very interesting find is a fragment of a clay pintadera.

KLJUČNE RIJEČI: Jačmica, neolitik, impresso kultura, vlaška grupa, danilska grupa, pintadera, eneolitik, nakovanska keramika, brončano doba

KEY WORDS: Jačmica, Neolithic, impresso culture, Vlačka group, Danilo group, pintadera, Eneolithic, Nakovana pottery, Bronze Age

OPIS PEĆINE I POVIJEST ISTRAŽIVANJA

Pećina Jačmica smještena je na gornjim stijenama brda Jačmica, visokog 466 m, koje se nalazi sjeverozapadno od grada Buzeta, u blizini sela Perci i Črnica. Ulaz je okrenut prema sjeveroistoku te se s njega pruža pogled na cijelu buzetsku kotlinu, a njegove koordinate, izmjerene GPS uređajem, s odstupanjem od 51 m, jesu: X 5417888, Y 5033946, Z 365 po Gauss - Kruegerovoj projekciji. Pećina se sastoji od dviju gotovo usporednih prostorija odijeljenih zidom, koje su spojene dvama otvorima (slika 1). Ulazna prostorija duga je 10, široka 5 i visoka 6 metara, a druga je duga 15, široka 4,5 i visoka 4 metra (Komšo/Miracle 2004, 151; Komšo/Miracle 2006, 29).

A DESCRIPTION OF THE CAVE AND HISTORY OF EXPLORATION

Jačmica cave lies in the upper rock wall of Jačmica Hill that is 466 m high and located to the northwest from the town of Buzet, in the vicinity of the villages of Perci and Črnica. The entrance to the cave is turned towards the northeast, offering thus a panoramic view of the entire Buzet basin; measured with a GPS instrument with a deviation of 51 m, its coordinates are: X 5417888, Y 5033946, Z 365, in accordance with the Gauss Krueger projection. The cave consists of two almost parallel areas divided by a wall, which are connected with two openings (Fig. 1). The entrance area is 10 m long, 5 m wide, and 6 m high, and the parallel one is 15 m long, 4.5 m wide, and 4 m high (Komšo/Miracle 2004, 151; Komšo/Miracle 2006, 29).

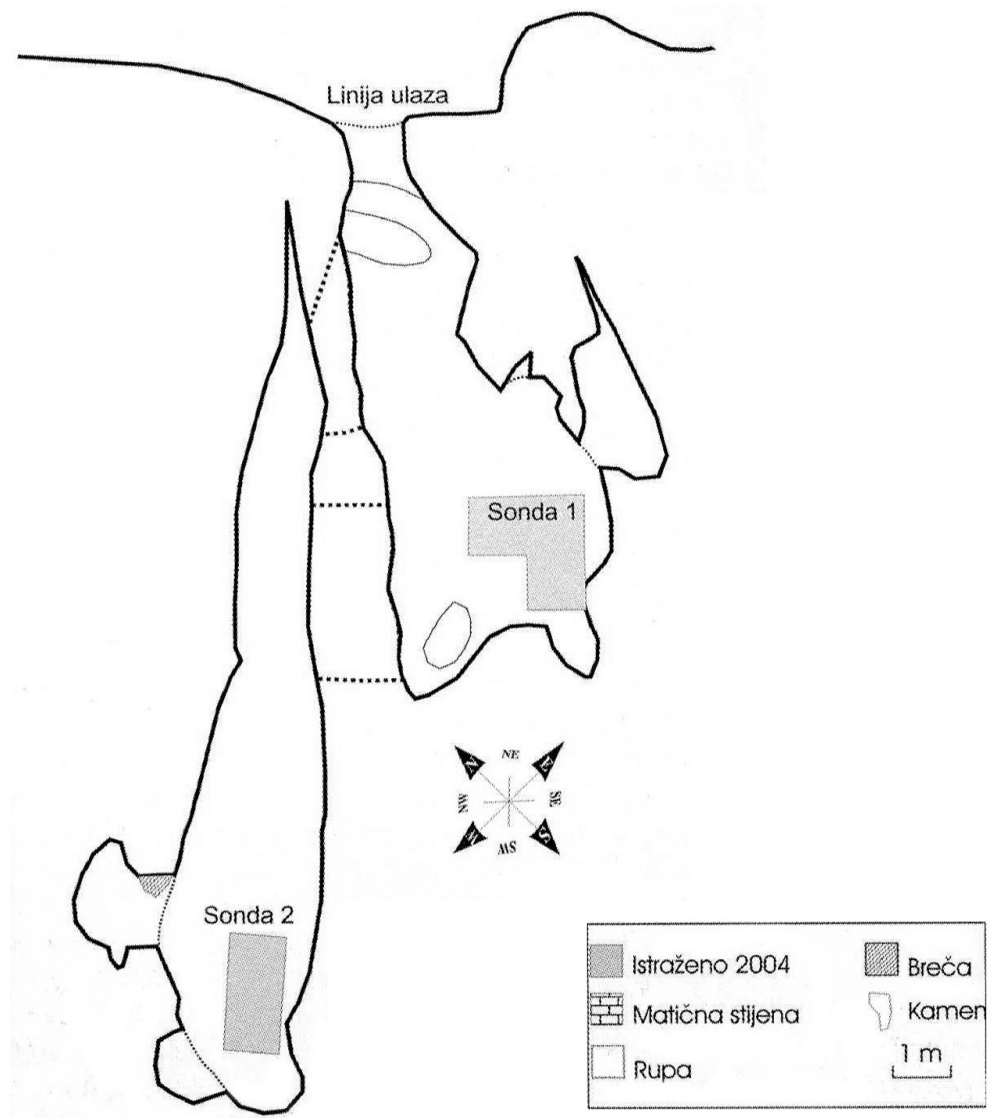

Sl. 1 Tlocrt pećine Jačmice s položajem sonde iz 2004. godine (preuzeto iz Komšo/Miracle 2004, 150)

Fig. 1 A ground plan of Jačmica cave showing the position of the probes from 2004 (Taken over from Komšo/Miracle 2004, 150).

Prva je istraživanja 1895. g. proveo Alberto Puschi, ravnatelj Museo Civico di Antichità di Trieste (Crismani 2003, 271; Komšo/Miracle 2004, 151; Komšo/Miracle 2006, 29) i član Società Istriana di Archeologia e Storia Patria (Crismani 2003, 271; Komšo), iskopavši dvije male sonde, po jednu u svakoj prostoriji pećine. Zabilježio je 54 ulomka keramike, analizu kojih je, kao i katalog, u članku objavila A. Crismani (Crismani 2003). Sve je nalaze pronašao u sondi iz unutrašnje prostorije, a osim keramike dokumentirao je i bakrenu sjekiru (Crismani 2003, 273; Fig. 4) te probušene kosti i morske školjke. Prikupljene nalaze usporedio je s onima iz obližnje Nugljanske peći (Komšo/Miracle 2004, 151; Komšo/Miracle 2006, 29-30), koju je također istraživao (Crismani 2003, 272). Po površinskoj istrošenosti pronađenih puževih kućica i s obzirom na druga nalazišta u regiji i Sredozemlju, starost ovih arheoloških nalaza upućivala je na razdoblje mezolitika. Iz tog razloga je od 19. srpnja do 5. kolovoza 2004. g. obavljeno arheološko istraživanje pećine, kao dio međunarodnog projekta "Paleolitička i mezolitička nalazišta sjevernog Jadrana", započetog 1995. godine. U istraživanju su sudjelovali djelatnici Arheološkog muzeja Istre u Puli, Zavoda za paleontologiju i geologiju kvartara HAZU iz Zagreba i Department of Archaeology - University of Cambridge iz Velike Britanije (Komšo/Miracle 2004, 150-151; Komšo/Miracle 2006, 30). U ovom radu predstavljena je izabrana prapovijesna keramika koja je pronađena tijekom tog istraživanja te su izneseni rezultati analize radioaktivnim ugljikom 14C (tablica 1).

The first explorations of the cave were conducted in 1895 by Alberto Puschi, the director of the Museo Civico di Antichità di Trieste (Crismani 2003, 271; Komšo/Miracle 2004, 151; Komšo/Miracle 2006, 29), and member of the Società Istriana di Archeologia e Storia Patria (Crismani 2003, 271; Komšo), when two small probes were excavated, one in each room of the cave. This resulted in 54 pottery fragments, an analysis of which, together with the catalogue, was published in a paper by A. Crismani (Crismani 2003). All the finds were unearthed in the probe located in the inner room, and except for pottery he also documented a bronze axe (Crismani 2003, 273; Fig. 4) as well as perforated bones and sea shells. He then proceeded by comparing these finds with the finds discovered in nearby Nugljanska cave (Komšo/Miracle 2004, 151; Komšo/Miracle 2006, 29-30) that he likewise explored (Crismani 2003, 272). Judging by the superficial wear of the discovered snail houses, and with regard to other sites in the region and in the Mediterranean, these archaeological finds were most probably from the Mesolithic period. It was with this in mind that an archaeological exploration of the cave was organized in the period from the 19th of July to the 5th of August, 2004, as part of an international project titled "Paleolithic and Mesolithic Sites in the Northern Adriatic", which was started in 1995. Participating in these excavations were the employees of the Archaeological Museum of Istria in Pula, the Institute for Quaternary Paleontology and Geology of the Croatian Academy of Sciences and Arts from Zagreb,

Tablica 1 Rezultati 14C analize iz pojedinih slojeva i tvorevina (izrada: K. Jerbić Percan, po rezultatima koje je ustupio D. Komšo)
Table 1 Results of C14 analysis from individual layers and features (Author: K. Jerbić Percan according to results provided by D. Komšo).

Uzorak / Sample	Naziv / Name	Nekalibrirano (prije sadašnjosti) / Uncalibrated (BP)	Godina prije Krista / BC/AD						Razdoblje / Period	Sloj / Level
			Od / From	Do / To	%	Od / From	Do / To	%		
Jačmica 1	OxA-18025	9115±45 BP	-8421	-8273	68,2	-8456	-8251	95,4	Rani mezolitik / Early mesolithic	3C
Jačmica 3	OxA-18181	6191±31 BP	-5213	-5074	68,2	-5286	-5039	95,4	Srednji neolitik / Middle neolithic	F5
Jačmica 4	OxA-18182	5263±31 BP	-4225	-3995	68,3	-4230	-3985	95,4	Kasni neolitik / Late neolithic	F4
Jačmica 6	OxA-18183	5325±29 BP	-4223	-4070	68,2	-4252	-4048	95,4	Rani eneolitik / Early Copper age	F2A

SONDA 1

U svakoj prostoriji pećine istražena je po jedna sonda. U ulaznoj prostoriji iskopana je sonda 1 (*slika 1, slika 2*), oblika slova "L" i površine 3 m², istražena do dubine od 120 cm. Zbog urušavanja profila i malog broja kulturnih ostataka u dubljim slojevima, nije iskopana do matične stijene. Definirano je 8 slojeva, od kojih su sloj 1 (T.1/1-3) i sloj 2 bili međusobno pomiješani, a u njima se nalazila keramika koju se tipološki može svrstati u različita prapovijesna razdoblja (Komšo/Miracle 2006, 32). Na jednom dijelu sloja 1 nalazilo se malo otvoreno vatrište, nazvano tvorevina 1 (*feature 1*), u kojem su nalazi bili uglavnom kosti i litika te malo keramike (T.1/4). Sloj 2X (T.1/5-8) također je bio poremećen. U sloju 3, koji je bio podijeljen na podslojeve 3A, 3B i 3C, javljali su se brojni nalazi spaljenog kamenja, životinjskih kostiju i litike, po čijoj su tipologiji relativno datirani u razdoblje mezolitika (Komšo 2006/2, 67; Komšo/Miracle 2006, 32), a ulomak oboda (T.1/9) jedini je određivi ulomak keramike, i to u sloju 3B. Analizom uzorka iz sloja 3C dobiven je radiokarbonski datum OxA-18025: 9115 ± 45 godina prije sadašnjosti, kalibrirani raspon od 8456. - 8251. godine prije Krista, s 95,4% vjerojatnosti, što ukazuje na razdoblje ranog mezolitika (Komšo 2006/2, 56, 60). Slojevi 4 do 8 bili su pjeskasti, vjerojatno geološki slojevi, s nekoliko ulomaka životinjskih kostiju (Komšo/Miracle 2006, 33).

SONDA 2

U unutrašnjoj prostoriji iskopana je sonda 2, dimenzija 2 x 1 m, istražena do dubine od 150 cm (*slika 1, slika 3*). Već prilikom čišćenja površine prostorije pronađeno je nekoliko ulomaka keramike (T.1/10-14; 2/1-6). U sondi 2 je također definirano 8 slojeva. Sloj 1 (T.2/7-12; 3/1-5) te 1X (T.2/6, 7) i 1Y (T.3/8-11) bili su pomiješani, a u njima je bilo nekoliko ulomaka prapovijesne te jedan ulomak antičke keramike (T.3/11). Ispod sloja 1 nalazio se sloj 2 (T.4-6; 7/1) uz koji su bila dva vatrišta nazvana tvorevinom 1 (T.7/2) i 2 (T.7/3-5) (*feature 1 i 2*), u kojima su osim keramike nađene životinjske kosti, morske školjke i sječivo od rožnjaka. Iz tvorevine 2 uzet je uzorak od kojeg je dobiven radiokarbonski datum OxA-18183: 5325 ± 29 godina prije sadašnjosti, kalibrirani raspon od 4252. - 4048. godine prije Krista, s 95,4% vjerojatnosti. Tvorevina 3 (*feature 3*), u dokumentaciji navedena kao otpadna jama za čišćenje vatrišta, sadržavala je brojne nalaze keramike (T.7/6-15, 8-10; 11/1-12), životinjske kosti, litiku te jednu pintaderu (T.11/13). Slični nalazi bili su prisutni i u slojevima 3 (T.11/14-16; 12-16) i 4 (T.17-

and the Department of Archaeology at the University of Cambridge from the United Kingdom (Komšo/Miracle 2004, 150-151; Komšo/Miracle 2006, 30). Presented in this work is a selection of prehistoric pottery discovered in the course of the mentioned excavation, as well as the results of an analysis of radioactive carbon 14C (*Table 1*).

PROBE 1

A single probe was explored in each room of the cave. The L-shaped probe 1 (*Fig. 1, Fig. 2*), with an area measuring 3 square meters, was dug in the entrance room, and it was explored up to a depth of 120 cm. This probe was not excavated to bedrock level because the profile caved in, and also due to the small number of culture remnants in the deeper layers. Eight layers were defined, out of which layer 1 (T.1/1-3) and 2 were mixed with one another, and they contained pottery that can be typologically ascribed to different prehistoric periods (Komšo/Miracle 2006, 32). Located on a section of layer 1 was a small, open area where fires were lit, named feature 1, which yielded finds that consisted mostly of bones, lithics and a small amount of pottery (T.1/4). Layer 2X (T.1/5-8) was also disturbed. In layer 3 which was further divided into sub-layers 3A, 3B and 3C, there appeared numerous finds consisting of burned stone, animal bones and lithics, and on the basis of their typology they were relatively dated to the Mesolithic period (Komšo 2006/2, 67; Komšo/Miracle 2006, 32), while a fragment of a rim (T.1/9) from layer 3B represents the only ageable pottery fragment discovered. An analysis of a sample from layer 3C yielded a radiocarbon date OxA-18025: 9115 ± 45 years before present, calibrated range from 8456-8251 BC with a 95.4% probability, which points to the period of the Early Mesolithic (Komšo 2006/2, 56, 60). Layers 4 to 8 were sandy, probably geological layers with several animal bones fragments (Komšo/Miracle 2006, 33).

PROBE 2

Probe 2 which was dug in the inner room, measured 2 x 1 meters, and it was explored up to a depth of 150 cm (*Fig. 1, Fig. 3*). Already during the cleaning of the surface area of the room several pottery fragments were discovered (T.1/10-14; 2/1-6). In probe 2 it was also possible to define 8 layers. Layer 1 (T.2/7-12; 3/1-5) and 1X (T.2/6, 7) as well as 1Y (T.3/8-11) were mixed, and they contained several fragments of prehistoric and a single fragment of Roman pottery (T.3/11). Located underneath layer 1 was layer 2 (T.4-6; 7/1) alongside which were two spots where fires were lit, named

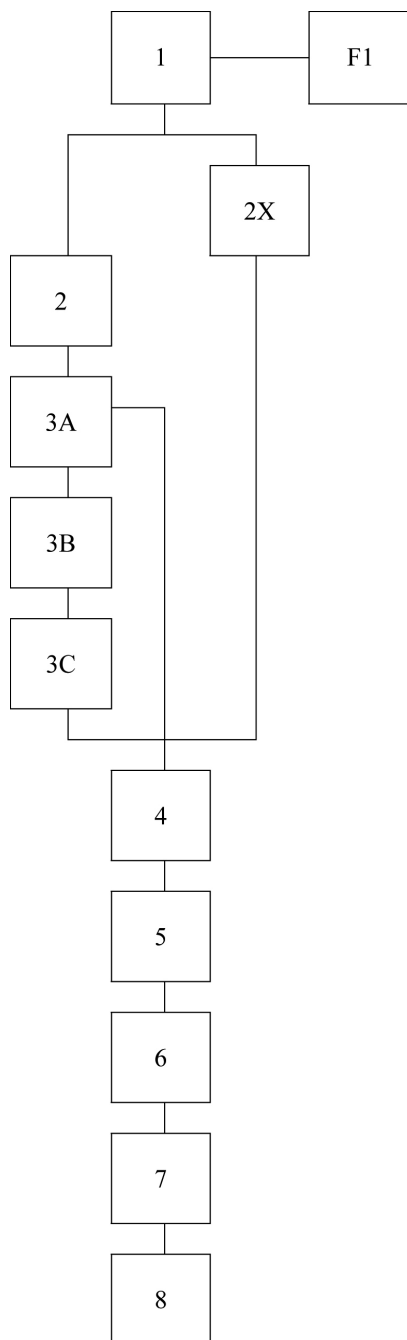

Sl. 2 Grafički prikaz odnosa između slojeva i tvorevina u sondi 1 (izrada: K. Jerbić Percan, po terenskoj dokumentaciji D. Komše)

Fig. 2 A graphic depiction of relations between layers and features in probe 1 (Author: K. Jerbić Percan according to field documentation of D. Komšo).

26, 27/1-4). U sloju 3 je osim keramike pronađen i privjesak izrađen od svinjskog zuba s rupicom za vješanje (Komšo/Miracle 2004, fotografija na str. 152; Komšo/Miracle 2006, gornja desna fotografija na str. 36), obrađeni jelenji rogovi, životinjske kosti, ugljen te kremena strelica i alatka na sječivju, a u sloju 4 kosti i morske školjke, ugljen te još jedna kremena strelica.

feature 1 (T.7/2) and 2 (T.7/3-5), in which besides pottery also animal bones, sea shells and blades made of chert were discovered. A sample was taken from feature 2, from which a radiocarbon date was obtained, OxA-18183: 5325 ± 29 years before present, calibrated range from 4252-4048 BC with a 95.4% probability. Feature 3, in the documentation referred to as a refuse pit for the disposal of waste from the spots where fires were lit, contained numerous pottery fragments (T.7/6-15, 8-10; 11/1-12), animal bones, lithics and a single pintadera (T.11/13). Similar finds were also present in layers 3 (T.11/14-16, 12-16) and 4 (T.17-26; 27/1-4). In layer 3, besides pottery, a pendant was discovered, which was made of a pig's tooth and equipped with a perforation for hanging (Komšo/Miracle 2004, photograph on page 152; Komšo/Miracle 2006, upper right photograph on page 36), as well as worked antlers, animal bones, coal, a flint arrow and a tool on the cutting edge, and in layer 4 there were bones and sea shells, coal as well as another flint arrow. Underneath the ground called layer 5, there was another spot where fires were lit feature 4 (T.27/5-9; 28/1-2), from where a sample was taken that produced a radiocarbon date, OxA-18182: 5263 ± 31 years before present, calibrated range from 4230-3985 BC with a 95.4% probability; and layer 6 (T.28/3-10). In feature 5, another spot where fires were lit, a small number of pottery finds were discovered, a single one of those was decorated with an impresso technique (T.28/11). A sample was taken from this feature as well, from which we obtained a radiocarbon date, OxA-18181: 6191 ± 31 years before present, calibrated range from 5286-5039 BC with a 95.4% probability. In layer 7, where cattle bones were absent and goat and sheep remains prevailed, pottery fragments from different periods were discovered (T.28/12-17; 29/1-7). Layer 8 is a sandy geological layer, almost devoid of any culture remnants (T.29/8-9) (Komšo/Miracle 2004, 150-151; Komšo/Miracle 2006, 32-35). The profiles were constantly caving in due to sediment that was very loose, and in the process of cleaning these profiles additional pottery fragments were discovered (T.29/10-14). The caving in of profiles is probably one of the main reasons for the disturbance regarding stratigraphic relations and pottery finds that were discovered in marked stratigraphic units. That is also the reason why in this work we attribute individual fragments to certain archaeological periods mostly on the basis of their typology. The appurtenant catalogue is organized with respect to stratigraphic contexts in each probe.

Ispod zemlje nazvane slojem 5 nalazilo se još jedno vatrište - tvorevina 4 (T.27/5-9; 28/1-2), iz koje je uzet uzorak od kojeg je dobiven radiokarbonski datum OxA-18182: 5263 ± 31 godina prije sadašnjosti, kalibrirani raspon od 4230. - 3985. godine prije Krista, s 95,4% vjerojatnosti; te sloj 6 (T.28/3-10). U tvorevini 5, još jednom vatrištu, nađen je mali broj keramičkih nalaza, s jednim koji je ukrašen impresso tehnikom (T.28/11). Iz ove tvorevine također je uzet uzorak od kojeg je dobiven radiokarbonski datum OxA-18181: 6191 ± 31 godina prije sadašnjosti, kalibrirani raspon od 5286. - 5039. godine prije Krista, s 95,4% vjerojatnosti. U sloju 7, u kojem izostaju kosti goveda i prevladavaju ostaci koža i ovaca, pronađeni su ulomci keramike iz različitih razdoblja (T.28/12-17; 29/1-7). Sloj 8 geološki je pjeskasti sloj, gotovo bez kulturnih ostataka (T.29/8-9) (Komšo/Miracle 2004, 150-151; Komšo/Miracle 2006, 32-35). Zbog vrlo rahlog sedimenta profili su se konstantno urušavali te je prilikom njihova čišćenja nađeno još nekoliko ulomaka keramike (T.29/10-14). Urušavanje profila vjerojatno je jedan od glavnih razloga poremećenosti stratigrafskih odnosa odnosno keramičkih nalaza koji su pronađeni u obilježenim stratigrafskim jedinicama. Iz tog razloga je u ovom radu pripisivanje pojedinih ulomaka određenim arheološkim razdobljima najviše temeljeno na njihovoj tipologiji. Katalog članka organiziran je po stratigrafskim kontekstima u svakoj sondi.

OPĆE KARAKTERISTIKE KERAMIČKIH NALAZA IZ PEĆINE JAČMICE

U iskopavanju su zabilježena 2.143 ulomka keramike, ukupne mase gotovo 32 kg. Izabrani ulomci predstavljaju obode, dna i ručke te sve one koji imaju ukras ili su na neki način specifični. Cjelokupni keramički i ostali materijal s iskopavanja, između ostalog i 319 inventarnih jedinica predstavljenih u članku, čuva se u prapovijesnoj zbirci u Arheološkom muzeju Istre u Puli. Izabrani ulomci uvedeni su u muzejski inventar pod brojevima P-51100 do P-51419 (osim P-51339).

Od svih ulomaka nađenih tijekom iskopavanja pećine, gotovo 40% bila je keramika metličasto obrađenih vanjskih ili unutrašnjih stijenki, a često je ukrašavanje obje strane. Zabilježena je u svim slojevima iskopa, zajedno s elementima odredivih prapovijesnih kultura. Također je zabilježena u iskopavanjima koje je vodio Pusch 1895. godine (Crismani 2003, 274). Pod metličasto obrađenom keramikom smatra se ona dosta kvalitetne fature, ponekad s vidljivim komadićima kvarcica, koja je "prošarana" nepravilnim, slabo ili

GENERAL CHARACTERISTICS OF POTTERY FINDS FROM JAČMICA CAVE

These excavations yielded a total of 2,143 pottery fragments with a total mass of almost 32 kg. The selected fragments represent rims, bases and handles as well as all fragments that either feature some sort of decoration or are specific in some other way. All pottery and other finds that resulted from these excavations, including amongst these the 319 inventory units presented in this

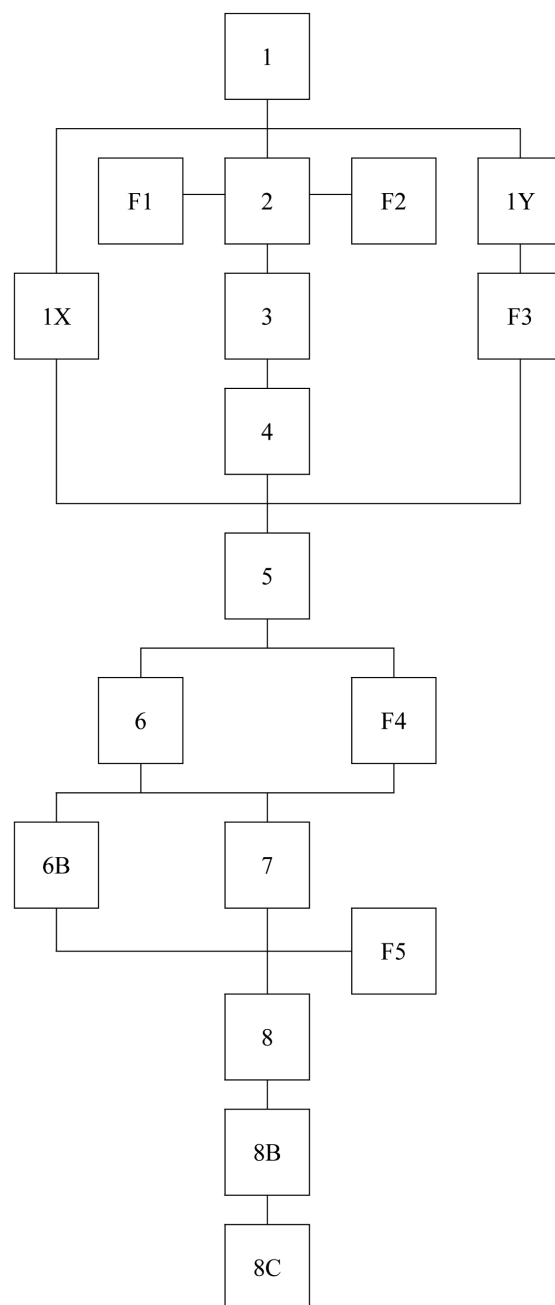

Sl. 3 Grafički prikaz odnosa između slojeva i tvorevina u sondi 2 (izrada: K. Jerbić Percan, po terenskoj dokumentaciji D. Komše)
Fig. 3 A graphic depiction of relations between layers and features in probe 2 (Author: K. Jerbić Percan according to field documentation of D. Komšo).

jako utisnutim te gusto ili rijetko prošaranim linijama, izvedenim metlicom ili nekim sličnim predmetom i većinom slijede vertikalnu posudu te tako oponašaju izgled košare od šiblja. Metličasto obrađene stijenke ponekad se koriste i kao podloga za jednostavne linije uboda ili plastičnu traku ukrašenu ubodima ispod oboda posude (Buršić-Matijašić 1990, 247-251). Autori koji su se bavili keramikom metličasto obrađenih stijenki imali su različite poglede na njezinu dataciju i pripadnost određenoj kulturi. Smještena je u šire vremensko razdoblje, od neolitika do potpunog nestanka u srednjem brončanom dobu, te se zbog toga smatra nepouzdanom u detaljnijem određivanju prapovijestih kultura (Crismani 2003, 281; Čuka 2009, 20-21; Zlatunić 2007, 462). Zanimljiv je primjerak metličaste obrade na ulomku trbuha posude iz Jačmice (T.16/8), gdje je unutrašnjost stijenke prošarana dubokim i širokim žljebovima paralelnim s linijom oboda, koji nije očuvan, a vanjski dio plićim i tanjim šarama koje su usmjerene okomito u odnosu na liniju oboda te žlijebove u unutrašnjosti.

Od 319 ulomaka njih 201 ima očuvan obod (T.1/1, 2, 4-7, 9-14; 2/1, 7-12; 3/1, 6-9; 4; 5/1-8; 7/2-4, 6-15; 8; 9; 10/1, 2; 11/14-16; 12; 13; 14/1-6; 16/2; 17; 18; 19; 20; 21; 22; 23; 24/1, 2; 27/5-8; 28/3-10, 12-17; 29/1-3, 10-13), a od toga ih je 57 (T.1/12-14; 2/1; 3/1, 7; 4/14-16; 5/1-6, 8; 8/8-12; 9/1, 3-5; 14/1-6; 19/2-4, 7-11; 20; 21/2, 4; 22/4; 23/2, 3; 27/6-8; 28/8-10; 29/13) s usnom ukrašenom utiscima noktom, prstom ili nekim instrumentom koji ostavlja sličan trag te jedan ulomak s ukrasom na usni izvedenim štipanjem (T.13/7). Četrnaest ulomaka je na vanjskoj stijenci ukrašeno plastičnom trakom s dodatnim ukrašavanjem utiscima prstom ili noktom (T.2/1; 5/8; 7/4; 8/7; 11/10; 14/5; 19/5-7, 11; 20/3-5; 28/9), a jedan ima samo plastičnu traku koja nije dodatno ukrašena (T.10/1). Također su prisutni ukrasi u vidu jednog reda utisaka na liniji ispod oboda bez plastične trake, i to njih 5 (T.3/7; 5/5; 8/3, 5; 9/2), a na jednom ulomku radi se o dva reda utisaka (T.5/6). Svi ulomci s ovakvim ukrasima na usni i neposredno ispod oboda imaju očuvani obod, osim jednog kojem se ne vidi obod, ali se po načinu izrade može pretpostaviti njegova neposredna blizina (T.11/10). Na jednom ulomku je na vanjskom zadebljanju oboda izveden valovit ukras (T.9/2).

Nakon oboda najčešći su ulomci s očuvanim dnom, njih 55 (T.2/2-4; 3/2, 3, 10; 5/9-12; 6/1-3; 10/2-7; 11/1-3; 14/7-14; 15/1-4; 24/2-14; 25; 27/9; 29/4, 9). Uglavnom se radi o jednostavnim, ravnim dnima, njih 41 (T.2/2-4; 3/2, 10; 5/11, 12; 6/2, 3; 10/2-6; 11/1; 14/7-10, 12-14; 15/1, 3, 4; 24/2-4, 6-9; 11-14; 25/1, 4, 5; 27/9; 29/9), te sedam primjeraka zaobljenih (T.3/3;

work, are kept within the prehistoric collection of the Archaeological Museum of Istria at Pula. The chosen fragments were introduced to the museum inventory under numbers P-51100 to P-51419 (except P-51339).

Out of all the fragments discovered in the course of exploration activities, almost 40% represent pottery with brushed outer or inner walls, and there are many examples that feature a brushed surface on both sides. Such pottery was recorded in all excavated layers together with elements of definable prehistoric cultures. This was also the case during the excavations conducted by Puschi in 1895 (Crismani 2003, 274). Brushed surface pottery is pottery with a relatively high-quality fabric, sometimes having visible bits of quartzite, which has been decorated with irregular, more or less impressed, and more or less dense lines that were executed with a brush or some similar object, and which for the most part run vertically with regard to the vessel, resembling thus a basket made of wattle. These brushed vessel wall surfaces serve at times as a background for a simple line of engraved points, or a plastic strap decorated with engraved points underneath the vessel rim (Buršić-Matijašić 1990, 247-251). Authors dealing with pottery decorated with brushed surfaces had diverging views as far as its dating and cultural affiliations are concerned. It has been placed in the broad period of time from the Neolithic to its complete disappearance in the Middle Bronze Age, and hence it is regarded as being unreliable for a more detailed determination of prehistoric cultures (Crismani 2003, 281; Čuka 2009, 20-21; Zlatunić 2007, 462). There is an interesting specimen of a brushed surface on a fragment of the belly of a vessel from Jačmica (T.16/8), where the inner side of the vessel wall was decorated with deep, wide channels that run parallel with the line of the rim that was not preserved, while the outer side features shallower and thinner lines that run vertically in relation to the line of the rim and the channels on the interior side.

Out of 319 fragments, 201 of them have a preserved rim (T.1/1, 2, 4-7, 9-14; 2/1, 7-12; 3/1, 6-9; 4; 5/1-8; 7/2-4, 6-15; 8; 9; 10/1, 2; 11/14-16; 12; 13; 14/1-6; 16/2; 17; 18; 19; 20; 21; 22; 23; 24/1, 2; 27/5-8; 28/3-10, 12-17; 29/1-3, 10-13), out of which 57 of them (T.1/12-14; 2/1; 3/1, 7; 4/14-16; 5/1-6, 8; 8/8-12; 9/1, 3-5; 14/1-6; 19/2-4, 7-11; 20; 21/2, 4; 22/4; 23/2, 3; 27/6-8; 28/8-10; 29/13) have a lip decorated with impressions made by a nail, finger or some other instrument that leaves a similar trace, and there is a single fragment with a lip decorated by pinching (T.13/7). There are 14 fragments that are on the outer side decorated by a plastic strap with additional decorations in the form of finger or nail impressions (T.2/1; 5/8; 7/4; 8/7; 11/10; 14/5; 19/5-7, 11; 20/3-5; 28/9), and there is a single one that has

5/9, 10; 24/10; 25/2, 3, 6) i šest dna s peticom (T.10/7; 11/2, 3; 14/11; 24/5; 29/4). Na donjoj površini tri dna vidi se ukras izveden utiskivanjem nekog predmeta, koji slični na uže (T.15/4; 25/5, 6).

Pronađeno je ukupno sedam ulomaka ručki očuvanih na stijenci posuda (T.2/5, 6; 5/7; 6/5; 15/5, 6; 26/2), tri samostalne (T.6/4; 11/4, 6; 26/1) te četiri ušice (T.11/5; 24/1; 26/3; 28/2).

Dvije posude su bile dovoljno očuvane da se u potpunosti rekonstruiraju (T.24/1, 2). Na posudi na T.24/1 nije bilo očuvanog dijela dna, ali je zbog stabilnosti predmeta dno izvedeno kao ravno. Posude su rekonstruirane u laboratoriju Arheološkog muzeja Istre u Puli. Na 16 ulomaka s očuvanim obodom (T.3/1; 9/5; 10/1, 2; 13/6; 21; 22; 23), 12 njih s očuvanim dnom (T.2/2; 11/2, 3; 14/14; 15/1, 2, 4; 25/2-4, 6; 29/4) te na jednom ulomku stijenke (T.27/4) mogao se izračunati promjer te tako djelomično rekonstruirati u crtežu. Rekonstrukcija u crtežu bila je moguća i kod predmeta nepoznate namjene na T.28/2.

Od ostalih keramičkih predmeta nađen je spomenuti predmet s ušicom (T.28/2), pintadera (T.11/13) te dva ulomka perforiranih posuda - cjedila (T.7/5; 11/7).

Osim već navedenih ukrašenih usna oboda te ulomaka s ukrasom reda utisaka ili plastičnom trakom ispod oboda, sa ili bez utisaka, pronađeno je još 47 ulomaka s ukrasom. Od toga su dva ulomka koji su ukrašeni impresso tehnikom utiskivanja nokta (T.28/11; 29/6) te još dva ukrašena cik-cak motivom (T.1/3; 16/3). Utiscima noktom ukrašen je i jedan ulomak ručke (T.6/5) i još jedan ulomak stijenke posude (T.28/1). Spiralni motiv prisutan je samo kod jednog ulomka (T.1/7), isto tako samo je jedan ulomak ukrašen kaneliranim koncentričnim kružnicama (T.1/8). Ukrasom šrafiranih trokuta ukrašena su tri ulomka (T.13/8; 28/2; 29/5). Njih četiri ukrašena su ubodima (T.3/4; 5/7; 26/4, 5), s tim da su neki ubodi kod ulomka na T.5/7 ispunjeni bijelom inkrustacijom. Na dva ulomka nalazi se ukras bradavica izvedenih štipanjem (T.21/4; 29/14) te na jednom ulomku plastična bradavica (T.29/7). Svi ostali ukrasi izvedeni su plitkim kaneliranjem, i to njih 21 (T.3/5; 4/12; 7/1; 12/13; 13/2; 16/4, 6; 17/9; 18/2; 22/2; 26/3, 8-14; 27/1, 2; 29/12). Primjer ukrašivosti predstavlja i pintadera uljepšana duboko urezanim cik-cak linijama unutar kojih se naziru tragovi crvene boje (T.11/13). U pećini je pronađen i jedan ulomak antičke keramike tankih stijenki, koji je ukrašen jednom izbočenom linijom te jednom kanelurom (T.3/11). Na šest ulomaka nalaze se razni ukrasi (T.6/11, 12; 11/11, 12; 16/5; 28/15) koji nisu interpretirani.

only a plastic strap that is not additionally decorated (T.10/1). There are also decorations that consist of a single row of impressions on the line underneath the rim, without a plastic strap, and there are 5 of those (T.3/7; 5/5; 8/3, 5; 9/2), and one fragment features two rows of impressions (T.5/6). All fragments that have such decorations on the lip and immediately underneath the rim have a preserved rim, except one, where the rim is not visible but it is possible to presume the immediate vicinity of the rim on account of the manner in which it was manufactured (T. 11/10). There is a fragment that features a wavy decoration on the exterior thickening of the rim (T.9/2).

After the fragments with a preserved rim, come those that have a preserved base, and there are 55 of them (T.2/2-4; 3/2, 3, 10; 5/9-12; 6/1-3; 10/2-7; 11/1-3; 14/7-14; 15/1-4; 24/2-14; 25; 27/9; 29/4, 9). For the most part they consist of simple, flat bases, and there are 41 of these (T.2/2-4; 3/2, 10; 5/11, 12; 6/2, 3; 10/2-6; 11/1; 14/7-10, 12-14; 15/1, 3, 4; 24/2-4, 6-9; 11-14; 25/1, 4, 5; 27/9; 29/9), as well as 7 specimens with a rounded base (T.3/3; 5/9, 10; 24/10; 25/2, 3, 6), and 6 bases with a small heel (T.10/7; 11/2, 3; 14/11; 24/5; 29/4). Visible on the nether surface of 3 bases are decorations that were impressed with some object and which resemble a rope (T.15/4; 25/5, 6).

A total of 7 fragments of handles preserved on the vessel wall were discovered (T.2/5, 6; 5/7; 6/5; 15/5, 6; 26/2), 3 handles were standing alone (T.6/4; 11/4, 6; 26/1), and there were 4 lugs (T.11/5; 24/1; 26/3; 28/2).

Two vessels were preserved enough to allow their thorough reconstruction (T.24/1, 2). Vessel T.24/1 lacked a section of the preserved base, but the base was reconstructed flat to insure the stability of the object. The vessels were reconstructed in the laboratory of the Archaeological Museum of Istria at Pula. For 16 fragments with a preserved rim (T.3/1; 9/5; 10/1, 2; 13/6; 21; 22; 23), 12 with a preserved base (T.2/2; 11/2, 3; 14/14; 15/1, 2, 4; 25/2-4, 6; 29/4), and for a single fragment of the vessel wall (T.27/4), it was possible to calculate the diameter and hence to partially reconstruct it in drawing. Reconstruction by drawing was also possible for an object of unknown purpose on T.28/2.

As far as the other pottery objects are concerned, we discovered the already mentioned object with a lug (T.28/2), a pintadera (T.11/13) and two fragments of perforated vessels sieves (T.7/5; 11/7).

Except for the already mentioned decorated lips of the rim and those fragments having a decoration in the form of a row of impressions or a plastic strap underneath the rim, with or without impressions, we discovered another 47 fragments that were decorated. Two of these were decorated in the impresso technique with nail

Kod ulomaka su česte rupice izvedene svrdlom nakon pečenja – u Jačmici ih nalazimo na njih 11 (T.6/6-10; 11/8, 9; 12/11; 16/1, 2; 27/3), a pretpostavlja se da su služile kao rupice za krpanje posuda nakon što su se razbile, ne bi li se mogle nastaviti koristiti (Forenbaher/Kaiser 2003, 76). Zanimljiv primjer sekundarnog korištenja vidljiv je na lomu ulomka s očuvanim obodom (T.17/16), na kojem je vidljivo da je izglačan nakon loma.

NEOLITIČKA KERAMIKA

Najstariji primjerci keramike u pećini jesu nekoliko sitnih ulomaka keramike impresso kulture, koja je za rani neolitik u pećinskim nalazištima Istre vrlo rijedak nalaz (Komšo 2003, 45; Marijanović 2007, 17), i to zbog toga što su u Istri za sada, osim u Jačmici, Šandalji (Bačić 1997, 30; Marijanović 2007, 17; Zlatunić 2007, Sl. 2) i vjerojatno Oporovini (Komšo 2004, 15; Zlatunić 2004, 6; Zlatunić 2007, Sl. 2), ranoneolitička nalazišta poznata samo na otvorenom, i to na njezinom južnom dijelu, u blizini mora (Bačić 1997; Komšo 2003; Komšo 2004; Marijanović 2007; Mihovilić 1986; Müller 1991; Müller 1994, 138-140; Zlatunić 2004, 6; Zlatunić 2007). Budući da se radi o vrlo malim ulomcima s neodredivih dijelova posude, interpretacija je utemeljena na načinu njihova ukrašavanja. Najstarije primjerke vjerojatno predstavljaju sitni ulomak sivosmeđe keramike, ukrašen dubokim i plitkim ubodima (T.28/11), nađen u tvorevini 5 sonde 2, te onaj sloju 7 (T.29/6) sonde 2, nešto većih dimenzija, također sivosmeđe boje, na kojem su vidljiva dva reda utisaka noktom ili nekim alatom koji stvara taj dojam (Marijanović 2009, 76). U tekstu je već navedeno da za tvorevinu 5 u kojoj je nađen jedan od ova dva ulomka (T.28/10) postoji radiokarbonski datum OxA-18181: 6191 ± 31 godina prije sadašnjosti, kalibrirani raspon od 5286. – 5039. godine prije Krista, s 95,4% vjerojatnosti. Po ostalim radiokarbonskim datumima na području tršćanskog Krasa, ovi datumi više odgovaraju vlaškom horizontu (Gilli/Montagnari Kokelj 1996, 64, 68/T.1; Montagnari Kokelj 2003, 76; Müller 1991, 345/Sl. 18, 355). Utisci nokta ili prsta predstavljaju najčešći motiv kod ukrašavanja stijenki impresso keramike, a drugu najčešću skupinu predstavljaju motivi izvedeni raznim alatima (Bregant 1968, 67). Takav način ukrašavanja – utiscima noktom i raznim alatima – po Batoviću je tipičan za fazu I (Batović 1979, 509) odnosno po Mülleru za impresso A fazu (Müller 1991, 325), datiranu u 6100. – 5800. godinu prije Krista (Müller 1991, 327). Od ostalih tipičnih načina ukrašavanja nađena su dva ulomka s djelomično vidljivim cik-cak ukrasom, karakterističnim za drugu fazu (Batović 1979, 509;

impressions (T.28/11; 29/6), two more were decorated with a zigzag motif (T.1/3; 16/3). A handle fragment was also decorated with nail impressions (T.6/5), as is the case with a vessel wall fragment (T.28/1). A single fragment is decorated with the spiral motif (T.1/7), and one with cannulated concentric circles (T.1/8). Three fragments are decorated with hatched triangles (T.13/8; 28/2; 29/5). Four fragments are adorned with engraved points (T.3/4; 5/7; 26/4, 5), and some of the engraved points on fragment T.5/7 are filled with a white incrustation. Two fragments are decorated with nubs executed by pinching (T.21/4; 29/14), and one fragment has a plastic nub (T.29/7). All other decorations consist of shallow channels, a total of 21 of them (T.3/5; 4/12; 7/1; 12/13; 13/2; 16/4, 6; 17/9; 18/2; 22/2; 26/3, 8-14; 27/1, 2; 29/12). An example of decoration can also be seen on the pintadera that is adorned with deeply incised zigzag lines within which there are traces of red color (T.11/13). A single fragment of Roman pottery was also discovered in the cave, which has thin walls and is decorated with a single protuberant line and a channel (T.3/11). Six of the fragments feature different decorations (T.6/11, 12; 11/11, 12; 16/5; 28/15) that are not interpreted.

Fragments were often equipped with small perforations executed with the help of a gimlet after the pottery was baked, and a total of 11 of these were unearthed at Jačmica (T.6/6-10; 11/8, 9; 12/11; 16/1, 2; 27/3). It is presumed that these perforations served for mending broken vessels in order to be able to use them again (Forenbaher/Kaiser 2003, 76). An interesting example for secondary vessel use can be observed at the breaking line of a fragment with a preserved rim (T.17/16), on which we can see that it was burnished after it was broken.

NEOLITHIC POTTERY

The oldest examples of pottery that was unearthed in the cave are several small fragments of impresso culture pottery which represents a very rare find for the Early Neolithic period in Istrian cave sites (Komšo 2003, 45; Marijanović 2007, 17). The reason for this is because to date in Istria, except in Jačmica, Šandalja (Bačić 1997, 30; Marijanović 2007, 17; Zlatunić 2007, Fig. 2) and probably Oporovina (Komšo 2004, 15; Zlatunić 2004, 6; Zlatunić 2007, Fig. 2), Early Neolithic sites were known only out in the open, on its southern part, in the vicinity of the sea (Bačić 1997; Komšo 2003; Komšo 2004; Marijanović 2007; Mihovilić 1986; Müller 1991; Müller 1994, 138-140; Zlatunić 2004, 6; Zlatunić 2007). Due to the fact that we are dealing with very small fragments from undefined vessel sections, we

Bregant 1968, 68; Müller 1991, 324-325; Težak-Gregl 1998, 77). Radi se o jednom ulomku smeđe glačane keramike s dvije urezane linije koje bi mogle biti dio cik-cak ukrasa iz poremećenog sloja 1 sonde 1 (T.1/3). Još jedan ulomak koji bi možda mogao predstavljati cik-cak ukras nađen je u sloju 3 sonde 2 (T.16/3), a radi se o gruboj, sivoj keramici. Ukrašavanje cik-cak motivom prvi puta se javlja u stupnju II impresso kulture po Batoviću (Batović 1979, 504) te se češće koristi u fazi III (Batović 1979, 509), a po Müllerovoj podjeli takvi motivi ukrašavanja tipični su za impresso B1 i 2 fazu (Müller 1991, 325). Ulomci keramike impresso kulture ukrašeni cik-cak motivima u Istri su nađeni i na Kargaduru kod Ližnjana (Komšo 2006/1, 235), Sv. Mihovilu kod Bala (Zlatunić 2007, 463; T.1/1, 2), Velej Gromači kod Kavrana na jugoistočnoj obali Istre (Bačić 1973, 14, T.III; Mihovilić 1986, 49; T.1/4, 5, 7), Verudici kod Pule (Bačić 1997, 30), Vižuli kod Medulina (Bačić 1969, T.VII; Mihovilić 1986, 49; T.1/1, 2; Müller 1994, 139; T.56, 58, 60, 62, 63) te Vrčevanu kod Medulina (Komšo 2004, 6-7; T.1/1, 2).

Neolitizaciju na području tršćanskog Krasa obilježila je tzv. vlaška grupa (Biagi/Voytek 1994, 64; Gilli/Montagnari Kokelj 1996, 63; Müller 1991, 329) za koju su karakteristični trbušasti lonci s izrazito uvrnutim obodom (oblik podsjeća na zatvoreni cvijet tulipana) i konkavnom kratkom nogom (u talijanskoj literaturi takvi lonci su često opisani kao *vasi a coppa*), široke zdjele i plitice (Gilli/Montagnari Kokelj 1996, 63; Korošec 1958, 121; Montagnari Kokelj/Boscarol/Jurišević 2011, 176). Vlašku i danilsku keramiku zbog visokog stupnja sličnosti u oblicima posuda i načinu ukrašavanja neki autori smatraju varijantama jedne srednjoneolitičke tradicije na istočnom Jadranu, a glavnu razliku čini odsutnost oslikavanja posuda kod vlaške keramike (Miracle/Forenbaheer 2006, 198-202). Keramika je jednobojna, pečena na relativno niskoj temperaturi (Gilli/Montagnari Kokelj 1996, 63; Miracle/Forenbaheer 2006, 178), ponekad s geometrijskim ukrasima u vidu visećih trokuta ili mrežastim motivom uz vanjski rub posude (Miracle/Forenbaheer 2006, 178; Müller 1991, 329). Analizom 14C provedenom nad dva uzorka iz horizonta vlaške grupe u pećini Grotta dei Ciclami na tršćanskom Krasu, ova keramika datirana je u 5280. - 5149., odnosno 5332. - 5068. g. prije Krista (Gilli/Montagnari Kokelj 1996, 64, 68/T.1; Montagnari Kokelj 2003, 76; Müller 1991, 345/sl. 18, 355). Osim ovih apsolutnih datuma, postoje i oni iz Grotta dell'Edera, s datacijom 5600. - 5300. g. prije Krista, te Grotta del Mitreo s datacijom od 4726. - 4543. g. prije Krista, što ovu grupu smješta u vrlo široko razdoblje

interpretirani na temelju načina ukrašavanja. Najstariji primjerci su vjerojatno predstavljeni malim fragmentima sive keramike ukrašene dubokim i plitim graviranim točkama (T.28/11), koji je otkriven u značajki 5 sonde 2, a drugi u sloju 7 (T.29/6) sonde 2, koji je nešto veći i također sive boje, na kojem su dva reda utisaka izvršena noktom ili nekim drugim alatom koji daje isti efekt (Marijanović 2009, 76). U tekstu je već spomenuto da za značajku 5, gdje je jedan od ovih dva fragmenta otkriven (T.28/10), postoji datacija radiokarbonom, OxA-18181: 6191 ± 31 godina prije sadašnjosti, kalibrirani raspon od 5286-5039 BC s 95.4% vjerojatnošću. Ako usporedimo ovo s drugim datacijama radiokarbonom iz Tršćanskog Karsta, tada ove datacije odgovaraju više vlaškoj horizonskoj (Gilli/Montagnari Kokelj 1996, 64, 68/T.1; Montagnari Kokelj 2003, 76; Müller 1991, 345/Sl. 18, 355). Utisak noktom ili prstom predstavlja najčešći dekorativni motiv na impresso posudama, slijedi grupa koja se sastoji od motiva izvršenih različitim alatom (Bregant 1968, 67). Ova vrsta ukrašavanja, izvršena utiskom noktom ili nekim drugim alatom, prema Batoviću tipična je za fazu I (Batović 1979, 509), a prema Mülleru za Impresso A fazu (Müller 1991, 325) datirana u 6100-5800 BC (Müller 1991, 327). Što se tiče drugih tipičnih dekorativnih motiva, otkriveni su dva fragmenta s djelomično vidljivim zickzack motivom, koji su karakteristični za drugu fazu (Batović 1979, 509; Bregant 1968, 68; Müller 1991, 324-325; Težak-Gregl 1998, 77). Jedan od ovih je fragment sive glazirane keramike s dvije urezane linije koje bi mogle biti dio zickzack dekorativnog motiva iz poremećenog sloja 1 sonde 1 (T.1/3). Drugi fragment koji bi možda predstavljao zickzack dekorativni motiv otkriven je u sloju 3 sonde 2 (T.16/3), a radi se o gruboj, sivoj keramici. Dekorativni motivi zickzack vrste pojavljuju se u fazi II impresso kulture, prema Batoviću (Batović 1979, 504), ali češće se koriste u fazi III (Batović 1979, 509), a prema Mülleru za Impresso B1 i 2 fazu (Müller 1991, 325). U Istri, impresso kultura keramike ukrašene zickzack motivima otkrivena je i na Kargaduru kod Ližnjana (Komšo 2006/1, 235), Sv. Mihovilu kod Bala (Zlatunić 2007, 463; T.1/1, 2), Velej Gromači kod Kavrana na jugoistočnoj obali Istre (Bačić 1973, 14, T.III; Mihovilić 1986, 49; T.1/4, 5, 7), Verudici kod Pule (Bačić 1997, 30), Vižuli kod Medulina (Bačić 1969, T.VII; Mihovilić 1986, 49; T.1/1, 2; Müller 1994,

od oko tisuću godina (Montagnari Kokelj 2003, 76). Već u Puschievim istraživanjima pronađeni su ulomci koji svojim oblikom sugeriraju na prisutnost slične keramike u Jačmici (Crismani 2003, 279) i obližnjoj Nugljanskoj pećini (Crismani 2001, 177). U Istri je vlaška keramika zabilježena i u horizontima I i H Pupićine peći (Miracle/Forenbaher 2006, 172; Sl. 5.5), koji su na temelju nekoliko uzoraka radiokarbonskom analizom datirani u razdoblje srednjeg neolitika (Miracle/Forenbaher 2006, 80-91; T. 3.1, Sl. 3.19). Postoji nekoliko ulomaka nađenih u istraživanju 2004. u Jačmici koji oblikom podsjećaju na vlašku keramiku, od kojih se ulomci širokih zdjela iz tvorevine 1B (T.7/2), sloja 2 (T.4/2), sloja 3 (T.12/9, 15; 13/2, 5) i sloja 4 (T.21/3) mogu relativno usporediti s ulomkom široke zdjele nađenim u Puschijevim istraživanjima koji je opisan kao karakterističan oblik kulture Danilo-Kakanj, a prisutan je i u vlaškoj keramici tršćanskog Krasa i Istre (Crismani 2003, 279, Fig. 7/11) te u Nugljanskoj pećini (Crismani 2001, 180; Fig.12/59-62). U Jačmici bi se vlaškoj keramici mogli pripisati brojni ulomci lonaca s očuvanim manje ili više uvučenim obodom, koji podsjećaju na one tipična izgleda otvorenog i zatvorenog cvijeta tulipana, i to u sloju 1 (T.2/9, 11, 12; 2/1), sloju 1X (T.3/6), sloju 1Y (T.3/8, 9), sloju 2 (T.4/4, 7, 8; 5/3-5), tvorevini 3 (T.7/11, 15; 8/5, 9, 10, 12; 9/2-5; 10/2), sloju 3 (T.12/1, 2, 7, 14; 13/3, 4; 14/6) sloju 4 (T.17/17; 18/5, 8-10; 19/4, 8, 9; 20/1; 21/2, 4; 22/1, 3, 4; 23), tvorevini 4 (T.27/7) sloju 7 (T.29/3) i sloju 8 (T.29/8). U Puschijevim istraživanjima također je pronađen jedan takav sličan ulomak, koji Crismani datiran u kasni neolitik, odnosno rani eneolitik Istre (Crismani 2003, 280; Fig. 6/2, gornja slika na str. 277). Svi ovi oblici mogu se usporediti s brojnim nalazima vlaške keramike na području tršćanskog Krasa (Gilli/Montagnari Kokelj 1996; Montagnari Kokelj/Boscarol/Jurišević 1976) te u Istri (Crismani 2001; Miracle/Forenbaher 2006). Također se s istim paralelama može povezati i ulomak trbuha posude s očuvanom vertikalnom ušicom (T.11/5). Mnogi od ovih ulomaka imaju metličasto obrađene stijenke te ukras s otiscima prsta ili nekog drugog instrumenta na usni oboda. Upotreba metličaste obrade stijenke poznata je i na vlaškoj keramici (Crismani 2003, 281; Miracle/Forenbaher 2006, 176-177). Također je kod takve keramike zabilježeno i ukrašavanje otiscima na ustima oboda (Gilli/Montagnari Kokelj 1996, 68; Miracle/Forenbaher 2006, 178; T. 5.1-5.5; Montagnari Kokelj/Boscarol/Jurišević 2011, 180).

Ulomak koji ukrasom i oblikom podsjeća na danilsku kulturu nađen je u pomiješanom sloju 2X sonde 1. Radi

139; T.56, 58, 60, 62, 63), and Vrčevan near Medulin (Komšo 2004, 6-7; T.1/1, 2).

The process of Neolithization was in the region of the Trieste Karst marked by the so-called Vlaška group (Biagi/Voytek 1994, 64; Gilli/Montagnari Kokelj 1996, 63; Müller 1991, 329), characteristic for which are globular pots with a distinctively inverted rim (the form is reminiscent of a closed tulip flower) and a short concave foot (in Italian literature such pots are often referred to as *vasi a coppa*), broad bowls and plates (Gilli/Montagnari Kokelj 1996, 63; Korošec 1958, 121; Montagnari Kokelj/Boscarol/Jurišević 2011, 176). Due to the high degree of similarity as regards vessel forms and decoration, some authors regard Vlaška and Danilo pottery as variants of a Middle Neolithic tradition in the eastern Adriatic, the main difference being that Vlaška pottery vessels were not painted (Miracle/Forenbaher 2006, 198-202). The pottery is monochrome, baked on a relatively low temperature (Gilli/Montagnari Kokelj 1996, 63; Miracle/Forenbaher 2006, 178), sometimes decorated with geometrical motifs consisting of hanging triangles or a reticular motif alongside the outer edge of a vessel (Miracle/Forenbaher 2006, 178; Müller 1991, 329). With a 14C analysis of two samples from the Vlaška group horizon in the Grotta dei Ciclami cave in the Trieste Karst, this pottery was dated to 5280-5149, and 5332-5068 BC (Gilli/Montagnari Kokelj 1996, 64, 68/T.1; Montagnari Kokelj 2003, 76; Müller 1991, 345/Sl. 18, 355). Except for these absolute dates, there are also those from the Grotta dell'Edera cave with a dating 5600-5300 BC, and the Grotta del Mitreo cave with a dating from 4726-4543 BC, which means that this group is placed into a very broad time span of approximately a thousand years (Montagnari Kokelj 2003, 76). Fragments were unearthed already during Puschi's excavations, which with their shape suggest a presence of similar pottery in Jačmica (Crismani 2003, 279) and the nearby Nugljanska cave (Crismani 2001, 177). In Istria, Vlaška pottery was recorded in horizons I and H of Pupićina cave (Miracle/Forenbaher 2006, 172; Fig. 5.5), which were on the basis of several samples, by means of a radiocarbon analysis dated to the period of the Middle Neolithic (Miracle/Forenbaher 2006, 80-91; T. 3.1, Fig. 3.19). There are several fragments that were unearthed during the excavation in 2004 at Jačmica, which on account of their form remind us of Vlaška pottery. Out of these we can make a relative comparison between the fragments of broad bowls from feature 1B (T.7/2), in layer 2 (T.4/2), layer 3 (T.12/9, 15; 13/2, 5) and layer 4 (T.21/3), with the fragment of a broad bowl that was discovered during Puschi's explorations, which was described as a characteristic form of the Danilo-Kakanj culture, and which is also

se o ulomku oboda neujednačene smeđe do sive boje, na čijoj stijenci su urezana dva reda paralelnih linija koje se kreću u smjeru oboda, a ispod donje linije vidljiv je ukras vezanih spirala (T.1/7), što je tipično danilski motiv (Bregant 1968, 73). Ukras na ovom ulomku može se usporediti s onim na posudama iz Smilčića (Batović 1979, T. LXXXIV/5, 8), a osim po ukrasu sličan je i po obliku s ulomcima nađenima na Lirskoj gradini (Bačić 1976, T. XIV/2, 3; Mihovilić 1986, T.1/10; Mihovilić 1990, 104/ Fig. 2), relativno datiranim u završnu fazu danilske i prijelaz na hvarsku kulturu (Mihovilić 1986, 50; Mihovilić 1990, 105). U Jačmici je nađeno nekoliko ulomaka ukrašenih plitko urezanim šrafiranim trokutićima, koji bi se također mogli interpretirati kao srednjoneolitički odnosno danilski. Prvi ulomak nađen je u sloju 3 sonde 2, a radi se o sitnom ulomku oboda plitice ili široke zdjele izrađene od crne, glačane keramike s ukrasom fino urezanog, visećeg, šrafiranog trokutića uz sam obod na unutrašnjoj stijenci posude (T.13/8). Crne, glačane stijenke karakteristika su fine danilske keramike, u čije se tipične oblike ubrajaju i plitice (Batović 1979, 541), što se poklapa s ovim ulomkom. Sličan ukras urezanih, šrafiranih, visećih trokutića uz rub unutrašnje stijenke tanjura nalazimo u Smilčiću (Batović 1979, T. LXXXIV/3). Osim ovog mogućeg ulomka plitice, u pećini je pronađena jedna gotovo cijela plitica bez očuvanog dna (T.21/1). U sloju 7 sonde 2 pronađen je sitni ulomak stijenke posude sive boje s primjesama kvarcita, na kojem se vidi jedan dio plitko urezanog šrafiranja (T.29/5). Ako se radi o trokutiću, na temelju tog ukrasa ovaj ulomak mogao bi se pripisati gruboj danilskoj keramici (Batović 1979, 541). U tvorevini 4 sonde 2 s već navedenim datumom za koju postoji OxA-18182: 5263 ± 31 godina prije sadašnjosti, kalibrirani raspon od 4230. – 3985. godine prije Krista, s 95,4% vjerojatnosti, pronađen je keramički predmet nepoznate namjene, izrađen od sive keramike s primjesama kvarcita (T.28/2). Ulomak svojim oblikom podsjeća na neku vrstu poklopca s otvorom na sredini. Na iznutra zadebljanom, blago izvučenom spoju gornje vodoravne i postranične stijenke koja se spušta prema dolje nalazi se ukošeno probijena ušica. Predmet je ukrašen plitkim i tankim urezima cik-cak linija i šrafiranim trokutima na vanjskim stijenama, po čemu bi se također mogao pripisati danilskoj kulturi.

U pećini je nađen zanimljiv ulomak oboda (*slika 4*; T.5/7) crvenkastosmeđe boje, koji je na jednom dijelu jezičasto izvijen prema van pa se čini kao da tvori kut, s očuvanom horizontalnom tunelastom ručkom i ukrasom dva reda uboda koji se kreću cik-

present in Vlačka pottery from the Trieste Karst and Istria (Crismani 2003, 279, Fig. 7/11), as well as in Nugljanska cave (Crismani 2001, 180; Fig.12/59-62). At Jačmica, numerous pot fragments could be ascribed to Vlačka pottery. These have a preserved, more or less inverted rim, and are reminiscent of those with a typical appearance of an open and closed tulip flower, and are from layer 1 (T.2/9, 11, 12; 2/1), layer 1X (T.3/6), layer 1Y (T.3/8, 9), layer 2 (T.4/4, 7, 8; 5/3-5), feature 3 (T.7/11, 15; 8/5, 9, 10, 12; 9/2-5; 10/2), layer 3 (T.12/1, 2, 7, 14; 13/3, 4; 14/6), layer 4 (T.17/17; 18/5, 8-10; 19/4, 8, 9; 20/1; 21/2, 4; 22/1, 3, 4; 23), feature 4 (T.27/7), layer 7 (T.29/3) and layer 8 (T.29/8). A similar fragment was unearthed during Puschi's excavations, which Crismani dates into the Late Neolithic, or the Early Eneolithic in Istria (Crismani 2003, 280; Fig. 6/2, upper figure on page 277). All of these forms can be compared with numerous finds of Vlačka pottery in the region of the Trieste Karst (Gilli/Montagnari Kokelj 1996; Montagnari Kokelj/Boscarol/Jurišević 1976) as well as in Istria (Crismani 2001; Miracle/Forenbaher 2006). The fragment of a vessel belly with a preserved vertical lug (T.11/5) can also be tied with these same analogies. Many of these fragments have brushed walls and feature a decoration that consists of impressions made by fingers or by some other instrument on the lip of the rim. Brushed vessel walls are also known from Vlačka pottery (Crismani 2003, 281; Miracle/Forenbaher 2006, 176-177). This kind of pottery also features decorations made by impressions on the mouth of the rim (Gilli/Montagnari Kokelj 1996, 68; Miracle/Forenbaher 2006, 178; T. 5.1-5.5; Montagnari Kokelj/Boscarol/Jurišević 2011, 180).

A fragment was unearthed in the disturbed layer 2X of probe 1, whose decoration and form are reminiscent of the Danilo culture. This fragment of the rim is brown to grey in color, and on its wall there are two incised rows of parallel lines that move in the direction of the rim, and visible underneath the lower line is a decoration that consists of tied spirals (T.1/7), which is a typical Danilo motif (Bregant 1968, 73). The decorative motif on this fragment can be compared with the one found on vessels from Smilčić (Batović 1979, T. LXXXIV/5, 8), and this is not the only similarity since its form can also be compared with the fragments discovered on Lirska Gradina (Bačić 1976, T. XIV/2, 3; Mihovilić 1986, T.1/10; Mihovilić 1990, 104/ Fig. 2). This form has a relative dating to the final phase of the Danilo culture and the transition to the Hvar culture (Mihovilić 1986, 50; Mihovilić 1990, 105). Several fragments decorated with small, shallow incised hatched triangles were unearthed at Jačmica, which could also be interpreted as Middle Neolithic and Danilo. The

cak, paralelno s obodom. U nekim ubodima vidljivi su tragovi bijele inkrustacije. Po načinu izrade oboda, koji je izvijen tako da tvori kut, te po boji keramike, izradi ručkice i bijeloj inkrustaciji, ovo bi mogao biti primjerak kulture u Italiji poznate kao *Cultura dei vasi a bocca quadrata*, odnosno kultura s posudama kojima je obod oblikovan u obliku kvadrata (Radmilli 1974, 342; Fig. 44), i to njezine stilske verzije *Stile a incisioni e impressioni* (Aspes 1984, 337; donja slika na str. 338). Ta kultura specifična je za srednji neolitik na području pokrajina Ligurije i Veneta u Italiji, gdje je u slojevima pećine Arene Candide apsolutno datirana oko 5465. ± 50, odnosno 5335. ± 50 godina prije sadašnjosti te na lokalitetu Isolino di Varese u 5534. ± 144 godine prije sadašnjosti, a javlja se još i u kasnom neolitiku i početkom eneolitika (Radmili 1974, 341). Za verziju *Stile a incisioni e impressioni*, posebno na području Veneta, smatra se da je bila povezana s jadransko-balkanskim područjem u kasnom neolitiku, odnosno zadnjoj fazi danilske i prvoj fazi hvarske kulture, a dovedene su u vezu ne samo zbog ukrašavanja keramike, nego i zbog pojave ženskih figurina od terakote te pintadera (Aspes 1984, 339; 345-346). Zanimljivo je da su za ovu fazu specifične pintadere s cik-cak motivima (Aspes 1984, 337; gornja slika na str. 338), a primjerak jedne s takvim motivom nađen je i u Jačmici. Još jedan ulomak *Cultura dei vasi a bocca quadrata* pronađen je u Jačmici u Puschijevim istraživanjima 1895. godine (Crismani 2003, 279; Fig.7/10).



Sl. 4 Ulomak oboda koji bi mogao biti primjerak *Cultura dei vasi a bocca quadrata* (fotografirala: K. Jerbić Percan)
Fig. 4 A fragment of a rim that could well be an example of *Cultura dei vasi a bocca quadrata* (Photographed by: K. Jerbić Percan).

first fragment was discovered in layer 3 of probe 2. It represents a small fragment of the rim from either a plate or a broad bowl, made of black, burnished pottery decorated with a small, finely incised, hanging, hatched triangle alongside the rim on the interior vessel wall (T.13/8). Black, burnished vessel walls are characteristic for fine Danilo pottery, and plates represent one of the typical forms of that pottery (Batović 1979, 541), all of which fits together with this fragment. A similar decoration consisting of incised, hanging, hatched triangles alongside the edge of the interior plate wall was discovered at Smilčić (Batović 1979, T. LXXXIV/3). Except for this fragment that possibly belongs to a plate, an almost whole plate was also discovered in the cave, lacking however its base (T.21/1). In layer 7 of probe 2 we discovered a small fragment of a vessel wall, grey in color, with quartzite temper, on which a section of a shallow incised hatching can be observed (T.29/5). Based on this decoration, and presuming it is a small triangle, then this fragment could be classified as Danilo coarse ware (Batović 1979, 541). In feature 4 of probe 2, for which there is an already mentioned date, OxA-18182: 5263 ± 31 BC, calibrated range from 4230-3985 BC with a 95.4% probability, an unidentified pottery object was discovered, made of grey clay tempered with quartzite (T.28/2). With its form this fragment is reminiscent of a lid with an opening in the middle. A transversely drilled lug is located on the inner thickening of the mildly drawn out juncture of the upper horizontal and lateral wall that descends downwards. This object is decorated with shallow and thin incisions representing zigzag lines and hatched triangles on the outer walls, on account of which it is possible to classify it as belonging to the Danilo culture.

An interesting reddish-brown fragment of a rim (Fig. 4; T.5/7) was discovered in the cave, which is in one section everted towards the outside in a linguiform manner, so that it appears as if though it forms a triangle. It has a small, preserved horizontal tunnel-handle and a decoration consisting of two rows of engraved points that are applied in a zigzag manner parallel to the rim. Traces of white inkrustation can be observed in some of these engraved points. Judging by the manner in which the rim was executed, which is everted and forms thus an angle, and taking into account the color of the pottery, the execution of the handle and the white inkrustation, this could very well be an example of the culture that in Italy is known as *Cultura dei vasi a bocca quadrata*, i.e., culture featuring vessels that have a square-shaped rim (Radmilli 1974, 342; Fig. 44), and to be precise, its stylish version, *Stile a incisioni e impressioni* (Aspes 1984, 337; lower figure on page 338). This culture is specific for the Middle Neolithic on the territory of the regions

PINTADERA

Termin *pintadera* dolazi od španjolske riječi “pintar”, što u prijevodu znači “bojati” (Skeates 2007, 196). Španjolski putnici u 16. stoljeću tako su nazivali keramičke pečate kojima su se po tijelu bojali starosjedioci Meksika. U modernoj literaturi prvi puta ih spominju etnolozi krajem 19. stoljeća kod opisa glinenih pečata koje su izrađivali žitelji Kanarskih otoka (Buršić-Matijašić 1993, 7; Cornaggia Castiglioni 1956, 109;). Budući da u hrvatskom jeziku ne postoji odgovarajući termin, u stručnoj literaturi najčešće se koristi ovaj izraz (Codacci-Terlević 2012, 16). Kao arheološki nalazi javljaju se u razdobljima neolitika, eneolitika i brončano doba (Buršić-Matijašić 1993, 8). Postoji nekoliko interpretacija čemu su služili, od identifikacijskih oznaka između zajednica, kao pečati za otiskivanje oznaka na keramičkim posudama, kao alati za izvođenje ukrasa na odjeći ili na dijelovima tijela, pa sve do oznake hijerarhijskog položaja pojedinca u zajednici te kao predmeti i motivi korišteni u religijskoj praksi (Marijanović 2008, 143-145), na primjer kao alat za pečatanje neke vrste kruha koji se koristio u ritualne svrhe (Buršić-Matijašić 1993, 7). Za pintadere koje svojim oblikom podsjećaju na oblik stošca, cilindra, piramide te ostala slična geometrijska tijela smatra se da su u ranom neolitiku služile kao pečati za označavanje količine neke sirovine ili kao neka vrsta identifikacije oznake u administrativne svrhe (Budja 1998, 221). Na području Istre i Krasa pronađeno je još nekoliko pintadera različitih tipova, i to na nalazištima Grotta Teresiana, Grotta delle Gallerie, Limska gradina, Brijuni - Saline i gradina Sv. Bartolomej na otoku Cresu, koje su uglavnom datirane u razdoblje kasnog neolitika i eneolitika (Buršić-Matijašić 1993, 9-10). Pintadera u obliku valjka pronađena je u Ravlića pećini u zapadnoj Hercegovini, u sloju s nalazima hvarsko-lisičićke kulture (Marijanović 2008, 142). Još jedna pintadera pronađena je i na Crnom vrilu, gdje je datirana u rani neolitik (Marijanović 2008, 142). Keramički pečat unutar sloja s nalazima impresso keramike spominje se kao nalaz u pećini Zemunici kod Biska u Dalmatinskoj zagori (Šošić/Karavanić 2005, 377).

Pintadera iz Jačmice (*slika 5; T.11/13*) “plosnatog” tipa (Buršić-Matijašić 1993, 9) nalazila se u tvorevini 3B sonde 2. Radi se o fragmentu jednog kraja pintadere prema kojem se može pretpostaviti da je njezin oblik bio pravokutni, izrađene od neujednačeno pečene žuto-crvenkaste keramike s primjesama kvarcita i pijeska. Ukrašena je duboko urezanim paralelnim cik-cak linijama usmjerenima paralelno s dužim stranicama,

of Liguria and Veneto in Italy, where in the layers of the Arena Candida cave, an absolute dating was obtained around 5465 ± 50 , or 5335 ± 50 years before present, as well as on the site of Isolino di Varese, 5534 ± 144 years before present, but it also appears in the Late Neolithic and at the beginning of the Eneolithic (Radmili 1974, 341). It is believed that the *Stile a incisioni e impressioni* version, and especially so in the region of Veneto, was connected with the Adriatic-Balkans territory in the Late Neolithic, in the last phase of the Danilo culture and the first phase of the Hvar culture. This link was observed not only based on pottery decorations, but also due to the appearance of female terracotta figurines and pintaderas (Aspes 1984, 339; 345-346). It is interesting to note that pintaderas with a zigzag motif are specific for this phase (Aspes 1984, 337; upper figure on page 338), and a specimen featuring just such a motif was unearthed at Jačmica. Another fragment of *Cultura dei vasi a bocca quadrata* was discovered in Jačmica during the excavations performed by Puschi in 1895 (Crismani 2003, 279; Fig.7/10).

THE PINTADERA

The word *pintadera* comes from Spanish “pintar”, which is a Spanish verb meaning “to paint” (Skeates 2007, 196). This was how Spaniards traveling in the 16th century called the decorative stamps made of clay, which the autochthonous population in Mexico used to paint their bodies. Ethnologists were the first ones to mention *pintaderas* in modern literature towards the end of the 19th century, when describing the clay stamps that were made by the inhabitants of the Canary Islands (Buršić-Matijašić 1993, 7; Cornaggia Castiglioni 1956, 109). As in the Croatian language we do not have an appropriate term for this, the term *pintadera* is used in professional literature (Codacci-Terlević 2012, 16). *Pintaderas* appear as archaeological finds in the period of the Neolithic, Eneolithic and the Bronze Age (Buršić-Matijašić 1993, 8). There are several interpretations for the use of *pintaderas*. They could have been used as identification marks between different communities, as stamps on pottery vessels, as instruments for decorating clothing and one’s own body, as marks of a hierarchical position of an individual in a community, and as objects and motifs employed in religious rituals (Marijanović 2008, 143-145), e.g., as a tool to stamp certain types of bread used for ritual purposes (Buršić-Matijašić 1993, 7). It is also believed that *pintaderas* whose forms were reminiscent of cones, cylinders, pyramids and other more or less similar geometrical bodies, in the Early Neolithic served as stamps to mark the quantity of a certain raw material, or as some kind of identification



Sl. 5 Ulomak pintadere (fotografirala: K. Jerbić Percan)
Fig. 5 A fragment of the pintadera (Photographed by: K. Jerbić Percan).

unutar kojih se mogu vidjeti naznake crvene boje, tipične za neolitička nalazišta Italije, istočnu obalu Jadrana i Grčke (Buršić-Matijašić 1993, 9). Ovakav način izvedbe ukrasa najsličniji je onima na pintaderama s nalazišta Hacilar u Turskoj, datiranim između 6090. i 5720. godine prije Krista (Budja 2003, 121/Fig. 5; 122), te onima iz Kunszentmárton-Jaksorérparta u Mađarskoj, po tipologiji pripisanima kulturi Körös-Starčevo (Makkay 1984, 31; T. 1/7 (124); T.VII/8 (124)) i Dikili Tasha (Makkay 1984, 19; T.XII/4 (48)).

ENEOLITIČKA KERAMIKA

Pojavu eneolitika na istočnoj jadranskoj obali obilježila je keramika karakterističnog izgleda i ukrasa, a radi se o tzv. nakovanskoj keramici (Mihovilić 1990, 105; Forenbaher 1999, 373; Petrić 1979, 215). Prvi ju je, na temelju nalaza kanelirane keramike nađene u spilji Nakovani na Pelješcu, definirao Nikša Petrić (Petrić 1979, 215). Tipične karakteristike nakovanske keramike su tamnosmeđe ili crne glačane stijenke, a oblici su konične zdjele s oblim trbuhom i cilindričnim vratom ukrašenim okomitim kanelurama koji završava blago izvijenim obodom te zdjele oštrije profiliranog trbuha i lagano stegnutog vrata, ukrašene kratkim okomitim kanelurama i plastičnim rebrima koja se radijalno spuštaju niz trbuh (Forenbaher 1999, 373; Petrić 1976, 305). Područje rasprostranjenosti nakovanske keramike počinje od Crne Gore pa preko srednjojadranskih otoka do Istre i tršćanskog Krasa (Čuka 2009, 18), a u Istri je karakteristična po tome što je, osim crne, ponekad crvenkaste i smeđe boje te nema toliku

mark used for administrative purposes (Budja 1998, 221). Several other types of pintaderas were unearthed on the territory of Istria and the Karst region, on sites such as Grotta Teresiana, Grotta delle Gallerie, Limska Gradina, Brijuni Saline, and the Sv. Bartolomej hillfort on the island of Cres, and for the most part they were dated into the period of the Late Neolithic and Eneolithic (Buršić-Matijašić 1993, 9-10). A pintadera shaped like a cylinder was discovered in Ravlića cave in western Herzegovina, in a layer containing finds from the Hvar-Lisičići culture (Marijanović 2008, 142). Another pintadera was unearthed at Crno Vrilo, where it was dated into the Early Neolithic (Marijanović 2008, 142). A clay stamp within a layer containing finds of impresso pottery is mentioned as a find from Zemunica cave near Bisak in Dalmatinska Zagora (Šošić/Karavanić 2005, 377).

The pintadera from Jačmica (Figure 5; T.11/13), which is of the “flat” type (Buršić-Matijašić 1993, 9), was located in feature 3B of probe 2. This is a fragment of one end of a pintadera and according to it we can presume that its form was rectangular. It was made of unevenly baked yellow-reddish clay tempered with quartzite and sand. Its decoration consists of deeply incised parallel zigzag lines that run parallel to the longer sides, within them a reddish color can be discerned, typical for Neolithic sites in Italy, the eastern Adriatic coast and Greece (Buršić-Matijašić 1993, 9). Such a mode of decoration is most similar to decoration found on pintaderas from the site of Hacilar in Turkey, dated between 6090 and 5720 BC (Budja 2003, 121/Fig. 5; 122), and those from Kunszentmárton-Jaksorérparta in Hungary, whose typology is ascribed to the Körös-Starčevo culture (Makkay 1984, 31; T. 1/7 (124); T.VII/8 (124)) and Dikili Tasha (Makkay 1984, 19; T.XII/4 (48)).

ENEOLITHIC POTTERY

The arrival of the Eneolithic period to the eastern Adriatic coast was marked by pottery that had a characteristic appearance and decoration, the so-called Nakovana pottery (Mihovilić 1990, 105; Forenbaher 1999, 373; Petrić 1979, 215). The first to define it was Nikša Petrić, based on finds of channeled pottery discovered in the Nakovana cave on Pelješac (Petrić 1979, 215). The typical characteristics of Nakovana pottery are burnished, dark brown or black walls, the forms being conical bowls with a round belly and a cylindrical neck decorated with vertical channels, the neck ending with a slightly everted rim, and bowls

raznolikost u oblicima kao u Dalmaciji. Na Brijunima je nađena i keramika koja po oblicima i kvaliteti pripada nakovanskoj, samo što nema kanelure (Čuka 2009, 19; Petrić 1979, 218). Oblici nađeni u Jačmici poklapaju se s onima nađenim na Brijunima (Petrić 1979, 218, T: XIII-XV), a u Istri su nalazi keramike ovog tipa pronađeni i na lokalitetima Srbani, Laganiši, Kargadur, Oporovina, Pupičina peć, Cingarela, Limska gradina, Dančeva pećina i Nezakcij (Čuka 2009, 19; Težak-Gregl 2009, 180). U Jačmici se u sondi 1 našao jedan ulomak koji bi se po obliku i glačanoj površini mogao pripisati nakovanskoj keramici (T.1/6). U sondi 2 nakovanska keramika počinje se javljati već u sloju 1 (T.3/5), nešto se češće javlja u sloju 2 (T.4/6, 10-13; 6/13; 7/1) i tvorevini 3 (T.7/7; 8/4, 6), a najveću koncentraciju ovakvih nalaza nalazimo u slojevima 3 (T.11/16; 12/3, 4, 13; 13/7; 16/4, 6, 7) i 4 (T.17/5, 9, 10, 13, 14, 18, 21; 18/2, 7, 11; 22/2; 24/1, 2; 26/1-3, 6-14; 27/1, 2). Sporadično se opet javlja u tvorevini 4 (T.27/5) te u nalazima iz urušenja profila (T.29/11, 12). U sloju 4 nađen je ulomak trbuha bikonične posude s okomitim kanelurama na najširem dijelu trbuha i s očuvanom okomito postavljenom subkutanom ušicom (T.26/3), što je također karakteristika nakovanske keramike (Crismani 2001, 180; Čečuk/Radić 2005, 226; Forenbaher 1999, 373), a pronađen je i veći ulomak posude koja se mogla rekonstruirati, na kojoj je vidljivo da je također imala takvu ušicu (T.24/1). Ulomak oboda široke zdjele s plastičnim ispupčenjem izvedenim štipanjem pripisan je eneolitiku, po usporedbi sa sličnim ulomkom nađenim u Veloj Spili na Korčuli (Čečuk/Radić 2005, str. 236, T.78/1).

Pretpostavljalo se da nakovanskoj keramici prethode nalazi hvarske kulture, no na nekim nalazištima hvarska i nakovanska keramika nalaze se u istim stratigrafskim kontekstima. Tako su kanelirani ukras i subkutane ušice u Veloj Spili obilježile završetak neolitika i početak eneolitika, odnosno fazu 4./3. hvarske kulture (Čečuk/Radić 2005, 155, 159, 227-228). Kaneliranje predstavlja najuobičajeniju tehniku ukrašavanja 2. faze Grapčeve špilje, što odgovara kasnoj hvarskoj kulturi, a u toj fazi su prisutne i subkutane ušice. Faza 1.3 i 2 Grapčeve špilje uspoređene su s fazama 4./3. i 4./4. hvarske kulture u Veloj Spili na Korčuli (Forenbaher/Kaiser 2008, 57; Tabla 18/5-7). Po dva radiokarbonska datuma iz faze 2 Grapčeve špilje, ova keramika datirana je u 4584. - 4359. godinu prije Krista, što je navedeno u opasci kao mogući prerani datum, te u 4041. - 3972. godinu prije Krista (Forenbaher/Kaiser 2008, 21; tablica 1). Zanimljivo je da su u Jačmici u tvorevinama 2A (4252. - 4058. godina prije Krista) i 4 (4230. - 3985. godina

with a more pronounced belly and a slightly constricted neck, which are decorated with short vertical channels and plastic ribs that descend radially down the belly (Forenbaher 1999, 373; Petrić 1976, 305). The area of dissemination of Nakovana pottery begins in Montenegro and goes over the middle Adriatic islands towards Istria and the Trieste Karst (Čuka 2009, 18). In Istria, this pottery has certain characteristics such as that it is not only black in color but also reddish and brown, and the diversity of forms is not as great as in Dalmatia. Earthenware that according to forms and quality belongs to Nakovana pottery was discovered on the Brioni Isles, albeit without any channels (Čuka 2009, 19; Petrić 1979, 218). The forms unearthed at Jačmica are in harmony with the ones discovered on Brioni (Petrić 1979, 218, T: XIII-XV), and in Istria pottery of this kind was also discovered on the sites of Srbani, Laganiši, Kargadur, Oporovina, Pupičina cave, Cingarela, Limska Gradina, Dančeva cave, Nezakcij (Čuka 2009, 19; Težak-Gregl 2009, 180). A fragment was discovered in probe 1 at Jačmica, which according to its form and burnished surface could be ascribed to Nakovana pottery (T.1/6), and in probe 2, Nakovana pottery began to appear already in layer 1 (T.3/5), it is more frequent in layer 2 (T.4/6, 10-13; 6/13; 7/1), and feature 3 (T.7/7; 8/4, 6), but the biggest concentration of such finds exists in layers 3 (T.11/16; 12/3, 4, 13; 13/7; 16/4, 6, 7) and 4 (T.17/5, 9, 10, 13, 14, 18, 21; 18/2, 7, 11; 22/2; 24/1, 2; 26/1-3, 6-14; 27/1, 2). Sporadically it again appears in feature 4 (T.27/5), and amongst the finds that resulted when the profile caved in (T.29/11, 12). In layer 4, a fragment of the belly of a biconic vessel was discovered, which had vertical channels on the broadest section of the belly, and a preserved vertically placed subcutaneous lug (T.26/3), all of which is likewise a characteristic of Nakovana pottery (Crismani 2001, 180; Čečuk/Radić 2005, 226; Forenbaher 1999, 373). A larger fragment from a vessel that we were able to reconstruct was likewise discovered, and on this vessel it was visible that it also had such a lug (T.24/1). A fragment of the rim of a broad bowl with a plastic protuberance executed by pinching was placed into the Eneolithic on the basis of a comparison with a similar fragment discovered at Vela Spila on Korčula (Čečuk/Radić 2005, page 236, T.78/1).

It was presumed that finds from the Hvar culture precede Nakovana pottery; however, on some sites both Hvar and Nakovana pottery are to be found in the same stratigraphic contexts. Thus channeled decoration and subcutaneous lugs at Vela Spila marked the end of the Neolithic and the beginning of the Eneolithic, and phase 4/3 of the Hvar culture (Čečuk/Radić 2005, 155,

prije Krista) dobiveni slični radiokarbonski datumi, no u tim stratigrafskim kontekstima kanelirana keramika gotovo da i nije prisutna. Dosadašnjim istraživanjima pokazalo se da nakon nakovanske keramike na području Dalmacije slijedi "Cetina 1", odnosno jadranski tip ljubljanske kulture, a moguće je da je između ta dva horizonta postojao još jedan "prijelazni" (Forenbaher 1999, 381).

BRONČANODOBNA KERAMIKA

U pećini je nađeno nekoliko ulomaka koji bi mogli biti brončanodobni. Tipičan način ukrašavanja keramike u brončanom dobu bila je plastična traka ispod oboda posude. Obično je ukrašena utiscima prstiju ili nekog tupog predmeta, ili pak zarezima izvedenima štapićem, no najčešće su to utisci prstiju. Često se ispod oboda javlja dodatno ukrašen dio ispod ruba oboda, a ponekad je takav ukras i samostalan, bez plastične trake. Za plastične trake ispod oboda posude još je 1903. g. Marchesetti primijetio da su najčešći ukras na keramici istarskih gradina, a javljaju se i u zapadnoj Sloveniji u keramici "kašteljerske kulture" (Buršić-Matijašić 1998, 95). Čović smatra da se plastične trake s utiscima prstiju javljaju početkom ranog brončanog doba Istre (Istra I), što ga razlikuje od zadnje faze eneolitika (Čović 1983, 130; Čuka 2009, 22). Bačić također svrstava ukras plastične trake u rano brončano doba (Bačić 1973, 10, T.VI/5). Primjerci ovakvog ukrašavanja zabilježeni su u Jačmici i prilikom iskopavanja koje je vodio Puschi 1895. godine (Crismani 2003, 277). U ovom iskopavanju pronađeno je ukupno 14 ulomaka s ukrasom plastične trake s utiscima prsta, i to kao površinski nalaz prostorije 2 (T.2/1), u sloju 2 (T.5/8), tvorevini 2B (T.7/4), tvorevini 3 (T.8/7; 11/10), sloju 3 (T.14/5), sloju 4 (T.19/5-7, 11; 20/3-5), te sloju 6 sonde 2 (T.28/9).

Ulomak trbuha posude nađen u pomiješanom sloju 2X sonde 1, tamnosmeđe boje, ukrašen koncentričnim, plitko kaneliranim kružnicama (T.1/8), možda je primjer brončanodobne keramike u Jačmici jer je takav ukras tipičan za kasno srednje brončano doba u Istri (Mihovilić 2008, 50).

U tvorevini 2B i 3B sonde 2 pronađeni su ulomci tamnosivih posuda s perforiranom stijenkama (T.7/5; 11/7), odnosno cjedila, za koja se smatra da su bila dio garniture za preradu mlijeka i procjeđivanje napitaka dobivenih namakanjem i fermentacijom žitarica ili voća (Mihovilić 2008, 51). Takve garniture poznate su iz apeninske kulture i nalazimo ih na istočnoj obali Jadrana (Forenbaher/Vranjčan 1985, 11). U Vaganačkoj pećini primjerak cjedila pripada fazi završetka srednjeg i početka kasnog brončanog doba (Forenbaher/

159, 227-228). Channeled ornamentation represents the most common form of decoration of the 2. phase of Grapčeva cave, which corresponds to the Late Hvar culture, and subcutaneous lugs are also present in this phase. Phases 1.3 and 2 of Grapčeva cave were compared with phases 4/3 and 4/4 of the Hvar culture in Vela Spila on Korčula (Forenbaher/Kaiser 2008, 57; Table 18/5-7). In accordance with two radiocarbon dates from phase 2 at Grapčeva cave, this pottery was dated to 4584-4359 BC, and in a remark it was stated that this possibly represents a dating that is too early, and to 4041-3972 BC (Forenbaher/Kaiser 2008, 21; Table 1). It is interesting to note that at Jačmica, in features 2A (4252-4058 BC) and 4 (4230-3985 BC), similar radiocarbon dates were obtained; however, in those stratigraphic contexts channeled pottery is almost non-existent. The research conducted to date has shown that Nakovana pottery on the territory of Dalmatia is followed by "Cetina 1", or the Adriatic type of the Ljubljana culture, and it is feasible that between these two horizons existed another "transitional" one (Forenbaher 1999, 381).

BRONZE AGE POTTERY

Several fragments were unearthed at the cave, which could possibly be from the Bronze Age. A plastic strap underneath the rim of a vessel was a typical mode of pottery decoration in the Bronze Age. Pottery was usually decorated by impressions made with fingers or some other blunt instrument, or by incisions executed with a small stick, but for the most part this was done with finger impressions. It is often the case that underneath the rim there is an additionally decorated section underneath the edge of the rim, and at times such decorations appear individually, without the plastic strap. It was Marchesetti, who way back in 1903 remarked that plastic straps underneath the rim of a vessel represent the most common mode of decoration on pottery from Istrian hillforts, and this decoration also appears in western Slovenia, on pottery of the "Castellieri culture" (Buršić-Matijašić 1998, 95). Čović believes that plastic straps with finger impressions appear at the beginning of the Early Bronze Age in Istria (Istria I), which makes it different from the last Eneolithic phase (Čović 1983, 130; Čuka 2009, 22). Bačić likewise classified the plastic strap decoration into the Early Bronze Age (Bačić 1973, 10, T.VI/5). Examples of such decoration were also recorded at Jačmica during the excavations conducted by Puschi in 1895 (Crismani 2003, 277). In this excavation a total of 14 fragments featuring a decoration consisting of a plastic strap with finger impressions were unearthed; as a superficial find in room 2 (T.2/1), in layer 2 (T.5/8), feature 2B (T.7/4),

Vranjčan 1985, 13), a u kasno brončano doba datirani su i u pećini Laganiši kod Oprtlja (Mihovilić 2008, 50). Jedan mogući ulomak cjedila zabilježen je i na brončanodobnoj gradini Monkodonji (Buršić-Matijašić 1998, 88) te na lokalitetu Sv. Mihovil kod Bala, koji je također datiran u brončano doba (Zlatunić 2007, T.II/6).

U sloju 7 sonde 2 pronađen je ulomak stijenke posude smeđe boje s apliciranom bradavicom (T.29/7). Početak bradavičastog ukrašavanja Čović smješta u drugu fazu ranog brončanog doba Istre (Čović 1983, 127). Ovaj ulomak može se usporediti s brojnim primjercima iz Monkodonje (Buršić-Matijašić 1998, T. 48-54).

ANTIČKA KERAMIKA

U sloju 1Y sonde 2 pronađen je ulomak stijenke posude malih dimenzija crne boje, s jednom blago izbočenom linijom te horizontalnom kanelurom (T.3/11). Po svojim malim dimenzijama, boji i načinu izrade ovaj ulomak podsjeća na antičku keramiku tankih stijenki koja je u emonskim rimskim nekropolama datirana u 1. i 2. stoljeće nakon Krista. Ulomak bi se mogao pripisati podvrsti malih posudica s glatkom površinom i kanelurama, koja je uže datirana u kraj 1. stoljeća nakon Krista (Plesničar Gec 1977, 13-14; T.1/10, 11), a može se usporediti i s čašama s visoko postavljenim narebrenim trbuhom iz Crikvenice, koje su bile lokalne izrade (Ožanić Roguljić 2011, 32; Kat. br. 11-15).

ZAKLJUČAK

Iz navedenih nalaza očigledno je da Jačmica zaslužuje značajno mjesto na karti prapovijesnih lokaliteta u Hrvatskoj i Istri te na području Krasa. Iako je iskopavanje 2004. bilo provedeno po svim pravilima arheološke struke, pokazalo se da su označene stratigrafske jedinice bile poremećene, što se vidi u raznolikosti keramičkih nalaza u istim slojevima, a to se dalo i naslutiti iz dnevničkih zapisa i terenske dokumentacije, u kojima je nekoliko puta navedeno da je zemlja rastresita i da se profili sonda često urušavaju. Bez obzira na takav tijek događaja, u iskopavanju koje je trajalo svega nekoliko tjedana nađena je značajna količina keramičkih nalaza, ali i kremenja te obrađenih i neobrađenih kostiju i zubi, koji su pokazali da se ova pećina u prapovijesti u manjem ili većem intenzitetu koristila od mezolitika do brončanog doba, s većim intenzitetom u neolitiku i eneolitiku, a vjerojatno je bila u upotrebi i kasnije. To potvrđuju, iako iz poremećenih slojeva, i analize radioaktivnim ugljikom. Zahvaljujući

feature 3 (T.8/7; 11/10), layer 3 (T.14/5), layer 4 (T.19/5-7, 11; 20/3-5), and in layer 6 of probe 2 (T.28/9).

A fragment of the belly of a vessel was discovered in the disturbed layer 2X of probe 1, it is dark-brown in color, decorated with concentric, shallow, cannulated circles (T.1/8), and it perhaps represents an example of Bronze Age pottery at Jačmica because such a decoration is typical for the late Middle Bronze Age in Istria (Mihovilić 2008, 50).

In features 2B and 3B of probe 2 we discovered fragments of dark-grey vessels with a perforated wall (T.7/5; 11/7), or sieves, for which it is believed that they were part of a set for milk processing and filtering of beverages obtained by sousing and fermentation of cereals or fruits (Mihovilić 2008, 51). Such sets are known from the Apennine culture and we encounter them on the eastern coast of the Adriatic (Forenbaher/Vranjčan 1985, 11). In Vaganačka cave, a sieve specimen belongs to the end phase of the Middle and the beginning of the Late Bronze Age (Forenbaher/Vranjčan 1985, 13), and in Laganiši cave near Oprtlj, it was also dated into the Late Bronze Age (Mihovilić 2008, 50). A single fragment of what could possibly have been a sieve was also recorded on the Bronze Age hillfort of Monkodonja (Buršić-Matijašić 1998, 88), and on the site of Sv. Mihovil near Bale, where it was likewise placed into the Bronze Age (Zlatunić 2007, T.II/6).

A brown vessel wall fragment with an applied nub (T.29/7) was discovered in layer 7 of probe 2. Čović puts the beginning of decoration with nubs into the second phase of the Early Bronze Age in Istria (Čović 1983, 127). This fragment can be compared with numerous examples from Monkodonja (Buršić-Matijašić 1998, T. 48-54).

ROMAN POTTERY

In layer 1Y of probe 2 we discovered a small, black fragment of a vessel wall, with a slightly protuberant line and a horizontal channel (T.3/11). With its small dimensions, color and mode of manufacture this fragment reminds us of thin-walled Roman pottery that was in the Roman necropolises at Emona dated into the 1st and 2nd century AD. This fragment could be included into a sub-type consisting of small vessels with a smooth surface and channels, which has been more precisely dated into the end of the 1st century AD (Plesničar Gec 1977, 13-14; T.1/10, 11). It could also be compared with glasses with a highly placed ribbed belly from Crikvenica, which were of local manufacture (Ožanić Roguljić 2011, 32; Cat. No. 11-15).

Albertu Puschiju te ovom iskopavanju, otkriven je još jedan zanimljiv lokalitet koji nam pomaže u rekonstrukciji života i obilježavanju kulturnih granica i poveznica u prapovijesnim razdobljima ovog područja. Ulomak pintadere te ulomak oboda za koji je zasad nesigurno pripada li keramici *Cultura dei vasi a bocca quadrata* predstavljaju rijetke nalaze i ukazuju na nedovoljnu istraženost i objavu rezultata modernih istraživanja s prapovijesnih, pogotovo neolitičkih i eneolitičkih nalazišta u Istri i okolici, što može biti dodatna motivacija u novim istraživanjima, analizama i interpretaciji arheološke građe.

CONCLUSION

From the described finds it is at once clear that Jačmica deserves a prominent place amongst prehistoric sites in Croatia and Istria and the Karst region. Although the excavation in 2004 was conducted strictly in accordance with all rules of the archaeological profession, it became nonetheless apparent that the marked stratigraphic units were disturbed, which can be seen from the diversity of pottery finds in the same layers. And this could have also been suspected from diaries and field documentation, where on several occasions it was stated that the soil was loose, and that probe profiles often caved in. Notwithstanding such a course of events, the excavations that only lasted for several weeks yielded a significant amount not only of pottery finds, but also of flint, as well as bones and teeth, some of which had been worked. All this shows that this cave was used with varying intensity during the prehistoric period, from the Mesolithic to the Bronze Age, with a greater intensity during the Neolithic and Eneolithic, and in all probability it was used afterwards as well. This is corroborated by analyses of radioactive carbon, although stemming from disturbed layers. Thanks both to Alberto Puschi and this excavation, it was possible to discover another interesting prehistoric site that helps us in the reconstruction of life as it once was, and the marking of cultural borders and links that existed in these territories during the prehistoric period. The fragment of a pintadera, and the fragment of a rim, for which we are not sure if it belongs to pottery of the *Cultura dei vasi a bocca quadrata*, both of them represent rare finds that highlight the insufficient degree of research and publication of the results of modern excavations on prehistoric, especially Neolithic and Eneolithic sites in Istria and the surrounding regions, all of which could serve as an additional motivation for new explorations, analyses and interpretations of archaeological materials.

KATALOG

*Crteže izradila: Katarina Jerbić Percan.
Grafički oblikovao: Tihomir Percan.*

TABLA 1**Sonda 1, sloj 1**

1. Izvijeni obod. Smeđa keramika s primjesama sitnih kamenčića. Glačana vanjska i unutrašnja površina stijenke. Dimenzije: 34,4 x 28,2 x 7,4 mm. Težina: 7,94 g. Inventarni broj: P-51201.
2. Ravni obod. Smeđa keramika s primjesama sitnih kamenčića i pijeska. Dimenzije: 31,5 x 13,2 x 6,1 mm. Težina: 4,08 g. Inventarni broj: P-51202.
3. Ulomak stijenke posude. Smeđa keramika s primjesama sitnih kamenčića i pijeska. Glačana vanjska površina stijenke. Ulomak ukrašen cik-cak motivom. Dimenzije: 45,7 x 19,0 x 6,7 mm. Težina: 6,77 g. Inventarni broj: P-51203.

Sonda 1, tvorevina 1

4. Izvijeni obod. Smeđa keramika. Glačana vanjska i unutrašnja površina stijenke. Dimenzije: 43,4 x 37,2 x 11,7 mm. Težina: 21,47 g. Inventarni broj: P-51196.

Sonda 1, sloj 2X

5. Ravni obod. Crna keramika s primjesama sitnih kamenčića. Glačana vanjska i unutrašnja površina stijenke. Dimenzije: 18,6 x 12,5 x 4,0 mm. Težina: 1,17 g. Inventarni broj: P-51192.
6. Izvijeni obod. Vanjska stijenka i usna smeđa, a unutrašnja stijenka crna keramika s primjesama sitnih kamenčića i pijeska. Glačana vanjska i unutrašnja površina stijenke. Dimenzije: 48,0 x 36,2 x 6,4 mm. Težina: 15,83 g. Inventarni broj: P-51191.
7. Ravni obod. Mrljasta (smeđa i tamnosiva) keramika s primjesama sitnih kamenčića i pijeska. Vanjska stijenka ukrašena s dvije paralelne linije koje prate smjer kretanja oboda, a s donje linije vise međusobno povezane spirale. Dimenzije: 40,5 x 23,1 x 6,8 mm. Težina: 8,43 g. Inventarni broj: P-51193.
8. Ulomak stijenke posude. Smeđa keramika s primjesama sitnih kamenčića. Glačana vanjska i unutrašnja površina stijenke. Ulomak ukrašen s tri savijene, međusobno paralelne kanelure. Dimenzije: 48,4 x 21,3 x 7,7 mm. Težina: 13,88 g. Inventarni broj: P-51194.

Sonda 1, sloj 3B

9. Ravni obod. Siva keramika s primjesama sitnih kamenčića. Dimenzije: 20,7 x 20,5 x 7,5 mm. Težina: 4,54 g. Inventarni broj: P-51206.

CATALOGUE

*Drawings: Katarina Jerbić Percan
Graphic design: Tihomir Percan*

TABLE 1**Probe 1, layer 1**

1. An everted rim. Brown pottery tempered with pebble grit. Burnished outer and inner wall surface. Dimensions: 34.4 x 28.2 x 7.4 mm. Weight: 7.94 g. Inventory Number: P-51201.
2. A flat rim. Brown pottery tempered with pebble grit and sand. Dimensions: 31.5 x 13.2 x 6.1 mm. Weight: 4.08 g. Inventory Number: P-51202.
3. A fragment of a vessel wall. Brown pottery tempered with pebble grit and sand. Burnished outer wall surface. The fragment is decorated with a zigzag motif. Dimensions: 45.7 x 19.0 x 6.7 mm. Weight: 6.77 g. Inventory Number: P-51203.

Probe 1, feature 1

4. An everted rim. Brown pottery. Burnished outer and inner wall surface. Dimensions: 43.4 x 37.2 x 11.7 mm. Weight: 21.47 g. Inventory Number: P-51196.

Probe 1, layer 2X

5. A flat rim. Black pottery tempered with pebble grit. Burnished outer and inner wall surface. Dimensions: 18.6 x 12.5 x 4.0 mm. Weight: 1.17 g. Inventory Number: P-51192.
6. An everted rim. Outer wall and lip, brown-colored pottery, inner wall black pottery tempered with pebble grit and sand. Burnished outer and inner wall surface. Dimensions: 48.0 x 36.2 x 6.4 mm. Weight: 15.83 g. Inventory Number: P-51191.
7. A flat rim. Flecked (brown and dark grey) pottery tempered with pebble grit and sand. Outer wall decorated with two parallel lines that follow the direction of the rim, hanging from the lower line are mutually connected spirals. Dimensions: 40.5 x 23.1 x 6.8 mm. Weight: 8.43 g. Inventory Number: P-51193.
8. A fragment of the vessel wall. Brown pottery tempered with pebble grit. Burnished outer and inner wall surface. The fragment is decorated with three twisted, mutually parallel channels. Dimensions: 48.4 x 21.3 x 7.7 mm. Weight: 13.88 g. Inventory Number: P-51194.

Probe 1, layer 3B

9. A flat rim. Grey pottery tempered with pebble grit. Dimensions: 20.7 x 20.5 x 7.5 mm. Weight: 4.54 g. Inventory Number: P-51206.

Prostorija 2, površinski nalazi

10. Izvijeni obod. Siva keramika. Dimenzije: 30,5 x 26,5 x 6,7 mm. Težina: 7,63 g. Inventarni broj: P-51415.
11. Ravni obod. Siva keramika s primjesama pijeska. Dimenzije: 49,1 x 44,5 x 7,8 mm. Težina: 24,24 g. Inventarni broj: P-51411.
12. Izvijeni obod. Usna ukrašena ubodima nekim predmetom okruglog presjeka. Siva keramika. Metličasto obrađena vanjska i unutrašnja površina stijenke. Dimenzije: 56,1 x 46,9 x 9,3 mm. Težina: 40,17 g. Inventarni broj: P-51412.
13. Ravni obod. Usna ukrašena utiscima noktom. Mrljasta (svjetlosiva i žuta) keramika s primjesama sitnih kamenčića i pijeska. Dimenzije: 66,0 x 64,5 x 9,4 mm. Težina: 54,72 g. Inventarni broj: P-51410.
14. Izvijeni obod. Usna ukrašena ubodima. Crvenkastosmeđa keramika s primjesama sitnih kamenčića. Dimenzije: 59,2 x 40,6 x 6,0 mm. Težina: 25,09 g. Inventarni broj: P-51407.

TABLA 2**Prostorija 2, površinski nalazi**

1. Ravni obod. Usna ukrašena utiscima prsta. Siva keramika s primjesama sitnih kamenčića i pijeska. Ispod usne oboda ulomak ukrašen plastičnom trakom s utiscima prstom. Utisci prstom vidljivi su i na prostoru između usne oboda i plastične trake. Dimenzije: 45,9 x 33,0 x 6,8 mm. Težina: 16,82 g. Inventarni broj: P-51419.
2. Ravno dno. Mrljasta (svjetlosiva i žuta) keramika s primjesama sitnih kamenčića i pijeska. Stijenka je ravna. Dimenzije: 89,3 x 83,3 x 8,3 mm. Težina: 76,95 g. Inventarni broj: P-51413.
3. Ravno dno. Siva keramika s primjesama sitnih kamenčića i pijeska. Stijenka je ravna. Dimenzije: 41,5 x 24,9 x 5,7 mm. Inventarni broj: P-51416.
4. Ravno dno. Mrljasta (smeđa i tamnosiva) keramika. Stijenka je konkavna. Dimenzije: 37,2 x 28,2 x 5,3 mm. Težina: 9,73 g. Inventarni broj: P-51417.
5. Ulomak stijenke posude na kojoj se vidi početak ručke. Smeđa keramika. Metličasto obrađena vanjska površina stijenke. Dimenzije: 72,7 x 55,8 x 6,8 mm. Težina: 44,92 g. Inventarni broj: P-51414.
6. Ulomak stijenke posude na kojoj se vidi početak ručke. Mrljasta (tamnosiva i smeđa) keramika. Metličasto obrađena vanjska površina stijenke. Dimenzije: 55,4 x 39,5 x 7,5 mm. Težina: 33,74 g. Inventarni broj: P-51418.

Room 2, superficial finds

10. An everted rim. Grey pottery. Dimensions: 30.5 x 26.5 x 6.7 mm. Weight: 7.63 g. Inventory Number: P-51415.
11. A flat rim. Grey pottery tempered with sand. Dimensions: 49.1 x 44.5 x 7.8 mm. Weight: 24.24 g. Inventory Number: P-51411.
12. An everted rim. The lip is decorated with points engraved with an unknown object having a circular cross-section. Grey pottery. Brushed outer and inner wall surface. Dimensions: 56.1 x 46.9 x 9.3 mm. Weight: 40.17 g. Inventory Number: P-51412.
13. A flat rim. The lip is decorated with nail impressions. Flecked (light grey and yellow) pottery tempered with pebble grit and sand. Dimensions: 66.0 x 64.5 x 9.4 mm. Weight: 54.72 g. Inventory Number: P-51410.
14. An everted rim. The lip is decorated with engraved points. Reddish-brown pottery tempered with pebble grit. Dimensions: 59.2 x 40.6 x 6.0 mm. Weight: 25.09 g. Inventory Number: P-51407.

TABLA 2**Room 2, superficial finds**

1. A flat rim. The lip is decorated with finger impressions. Grey pottery tempered with pebble grit and sand. Underneath the lip of the rim the fragment is decorated with a plastic strap having finger impressions. Finger impressions are also visible in the area between the lip of the rim and the plastic strap. Dimensions: 45.9 x 33.0 x 6.8 mm. Weight: 16.82 g. Inventory Number: P-51419.
2. A flat base. Flecked (light grey and yellow) pottery tempered with pebble grit and sand. The wall is flat. Dimensions: 89.3 x 83.3 x 8.3 mm. Weight: 76.95 g. Inventory Number: P-51413.
3. A flat base. Grey pottery tempered with pebble grit and sand. The wall is flat. Dimensions: 41.5 x 24.9 x 5.7 mm. Inventory Number: P-51416.
4. A flat base. Flecked (brown and dark grey) pottery. The wall is concave. Dimensions: 37.2 x 28.2 x 5.3 mm. Weight: 9.73 g. Inventory Number: P-51417.
5. A fragment of the vessel wall on which the beginning of a handle can be observed. Brown pottery. Brushed outer wall surface. Dimensions: 72.7 x 55.8 x 6.8 mm. Weight: 44.92 g. Inventory Number: P-51414.
6. A fragment of the vessel wall on which the beginning of a handle can be observed. Flecked (dark grey and brown) pottery. Brushed outer wall surface. Dimensions: 55.4 x 39.5 x 7.5 mm. Weight: 33.74 g. Inventory Number: P-51418.

Sonda 2, sloj 1

7. Izvijeni obod. Smeđa keramika s primjesama sitnih kamenčića i pijeska. Metličasto obrađena vanjska i unutrašnja površina stijenke. Dimenzije: 35,0 x 33,0 x 6,8 mm. Težina: 11,13 g. Inventarni broj: P-51376.
8. Izvijeni obod. Siva keramika s primjesama sitnih kamenčića i pijeska. Dimenzije: 26,1 x 20,7 x 3,8 mm. Težina: 3,71 g. Inventarni broj: P-51378.
9. Izvijeni obod. Siva keramika s primjesama sitnih kamenčića i pijeska. Dimenzije: 27,4 x 25,4 x 5,6 mm. Težina: 5,56 g. Inventarni broj: P-51377.
10. Izrazito izvijeni obod. Crna keramika s primjesama sitnih kamenčića i pijeska. Dimenzije: 34,5 x 33,2 x 7,7 mm. Težina: 9,08 g. Inventarni broj: P-51375.
11. Izvijeni obod. Žuta keramika s primjesama sitnih kamenčića. Metličasto obrađena vanjska i unutrašnja površina stijenke. Dimenzije: 33,0 x 30,1 x 6,9 mm. Težina: 9,18 g. Inventarni broj: P-51379.
12. Izvijeni obod. Smeđa keramika s primjesama sitnih kamenčića i pijeska. Metličasto obrađena vanjska površina stijenke. Dimenzije: 55,6 x 39,1 x 10,3 mm. Težina: 31,51 g. Inventarni broj: P-51170.

TABLA 3**Sonda 2, sloj 1**

1. Uvučeni obod. Usna je ukrašena nizom ukošenih ureza. Izvana mrljasta (smeđa i tamnosiva), a iznutra crna keramika. Metličasto obrađena vanjska površina stijenke. Dimenzije: 106,0 x 65,1 x 8,7 mm. Težina: 102,91 g. Inventarni broj: P-51380.
2. Ravno dno. Siva keramika s primjesama sitnih kamenčića. Stijenka je ravna i metličasto obrađena na vanjskoj površini. Dimenzije: 59,7 x 27,7 x 6,7 mm. Težina: 12,88 g. Inventarni broj: P-51382.
3. Zaobljeno dno. Siva keramika s primjesama sitnih kamenčića. Nema očuvane stijenke. Dimenzije: 63,0 x 36,6 x 12,0 mm. Težina: 37,43 g. Inventarni broj: P-51381.
4. Ulomak stijenke posude. Izvana glačana, mrljasta (smeđa i crna), iznutra smeđa i bez glačanja. Keramika s primjesama sitnih kamenčića. Vidljiva jedna cijela i naznaka još jedne rupice za koje se ne može sa sigurnošću utvrditi jesu li izvedene prije ili poslije pečenja (?). Dimenzije: 38,1 x 28,0 x 5,6 mm. Težina: 7,34 g. Inventarni broj: P-51383.
5. Ulomak stijenke bikonične posude s mjesta gdje je trbuh najširi i vidi se bikoničnost. Izvana glačana, mrljasta (smeđa i tamnosiva), iznutra glačana i crna keramika. Na najširem dijelu trbuha nalazi se ukras izrazito plitkih i jedva vidljivih tankih, paralelnih

Probe 2, layer 1

7. An everted rim. Brown pottery tempered with pebble grit and sand. Brushed outer and inner wall surface. Dimensions: 35.0 x 33.0 x 6.8 mm. Weight: 11.13 g. Inventory Number: P-51376.
8. An everted rim. Grey pottery tempered with pebble grit and sand. Dimensions: 26.1 x 20.7 x 3.8 mm. Weight: 3.71 g. Inventory Number: P-51378.
9. An everted rim. Grey pottery tempered with pebble grit and sand. Dimensions: 27.4 x 25.4 x 5.6 mm. Weight: 5.56 g. Inventory Number: P-51377.
10. A particularly everted rim. Black pottery tempered with pebble grit and sand. Dimensions: 34.5 x 33.2 x 7.7 mm. Weight: 9.08 g. Inventory Number: P-51375.
11. An everted rim. Yellow pottery tempered with pebble grit. Brushed outer and inner wall surface. Dimensions: 33.0 x 30.1 x 6.9 mm. Weight: 9.18 g. Inventory Number: P-51379.
12. An everted rim. Brown pottery tempered with pebble grit and sand. Brushed outer wall surface. Dimensions: 55.6 x 39.1 x 10.3 mm. Weight: 31.51 g. Inventory Number: P-51170.

TABLA 3**Probe 2, layer 1**

1. A drawn in rim. The lip is decorated with a series of slanted incisions. Flecked (brown and dark grey) pottery on the exterior, black on the interior. Brushed outer wall surface. Dimensions: 106.0 x 65.1 x 8.7 mm. Weight: 102.91 g. Inventory Number: P-51380.
2. A flat base. Grey pottery tempered with pebble grit. The wall is flat and brushed on the exterior surface. Dimensions: 59.7 x 27.7 x 6.7 mm. Weight: 12.88 g. Inventory Number: P-51382.
3. A rounded base. Grey pottery tempered with pebble grit. The wall is not preserved. Dimensions: 63.0 x 36.6 x 12.0 mm. Weight: 37.43 g. Inventory Number: P-51381.
4. A fragment of the vessel wall. Burnished and flecked (brown and black) on the outside, brown, not burnished on the inside. Pottery tempered with pebble grit. One whole perforation is visible, another one is implied, for both of them it is not possible to say whether they were made before or after baking (?). Dimensions: 38.1 x 28.0 x 5.6 mm. Weight: 7.34 g. Inventory Number: P-51383.
5. A fragment of the wall of a carinated vessel from the section where the belly is at its broadest and the carination can be observed. Burnished and flecked (brown and dark grey) on the outside, black and

kanelura koje su usmjerene okomito na liniju trbuha posude. Dimenzije: 94,5 x 42,7 x 7,4 mm. Težina: 43,22 g. Inventarni broj: P-51384.

Sonda 2, sloj 1X

6. Izvijeni obod. Tamnosiva keramika s primjesama sitnih kamenčića. Metličasto obrađena vanjska i unutrašnja površina stijenke. Dimenzije: 59,2 x 38,5 x 6,8 mm. Težina 24,44 g. Inventarni broj: P-51204.
7. Izvijeni obod. Usna je ukrašena utiscima noktom. Siva keramika s primjesama sitnih kamenčića. Metličasto ukrašena vanjska površina stijenke, na kojoj se vidi niz utisaka nekim tupim predmetom paralelno s obodom. Dimenzije: 32,2 x 29,5 x 4,6 mm. Težina: 5,33 g. Inventarni broj: P-51205.

Sonda 2, sloj 1Y

8. Izvijeni obod. Smeđa keramika s primjesama sitnih kamenčića i pijeska. Metličasto obrađena na malom dijelu vanjske i po cijeloj površini unutrašnje stijenke. Dimenzije: 24,9 x 25,6 x 5,8 mm. Težina: 5,22 g. Inventarni broj: P-51197.
9. Izvijeni obod. Smeđa keramika s primjesama pijeska. Metličasto obrađena vanjska površina stijenke. Dimenzije: 30,6 x 24,6 x 7,0 mm. Težina: 8,6 g. Inventarni broj: P-51198.
10. Ravno dno. Crvenkastosmeđa keramika s primjesama sitnih kamenčića i pijeska. Stijenka je ravna. Dimenzije: 28,2 x 27,2 x 9,7 mm. Težina: 11,06 g. Inventarni broj: P-51199.
11. Ulomak stijenke posude izrađene u kalupu. Crna keramika ukrašena jednom blago izbočenom linijom te ispod nje jednom kanelurom. Dimenzije: 25,4 x 24,0 x 4,3 mm. Težina: 2,11 g. Inventarni broj: P-51200.

TABLA 4

Sonda 2, sloj 2

1. Izvijeni obod. Izvana smeđa, iznutra siva keramika s primjesama pijeska. Dimenzije: 15,5 x 13,5 x 4,1 mm. Težina: 1,41 g. Inventarni broj: P-51314.
2. Izvijeni obod (?). Izvana tamnosiva, iznutra smeđa keramika s primjesama pijeska. Dimenzije: 32,4 x 24,0 x 7,7 mm. Težina: 6,30 g. Inventarni broj: P-51393.
3. Ravni obod. Izvana mrljasta (crna i smeđa), iznutra smeđa keramika s primjesama sitnih kamenčića. Metličasto obrađena vanjska površina stijenke. Dimenzije: 24,2 x 19,3 x 5,9 mm. Težina: 2,97 g. Inventarni broj: P-51312.

burnished on the inside. Located on the broadest section of the belly is a decoration consisting of very shallow and barely visible, thin, parallel channels that point vertically to the line of the vessel belly. Dimensions: 94.5 x 42.7 x 7.4 mm. Weight: 43.22 g. Inventory Number: P-51384.

Probe 2, layer 1X

6. An everted rim. Dark grey pottery tempered with pebble grit. Brushed outer and inner wall surface. Dimensions: 59.2 x 38.5 x 6.8 mm. Weight 24.44 g. Inventory Number: P-51204.
7. An everted rim. The lip is decorated with nail impressions. Grey pottery tempered with pebble grit. Brushed outer wall surface, on it a series of impressions running parallel to the rim and made with some blunt object are visible. Dimensions: 32.2 x 29.5 x 4.6 mm. Weight: 5.33 g. Inventory Number: P-51205.

Probe 2, layer 1Y

8. An everted rim. Brown pottery tempered with pebble grit and sand. Brushed on a small section of the outer wall, and over the entire surface of the inner one. Dimensions: 24.9 x 25.6 x 5.8 mm. Weight: 5.22 g. Inventory Number: P-51197.
9. An everted rim. Brown pottery tempered with sand. Brushed outer wall surface. Dimensions: 30.6 x 24.6 x 7.0 mm. Weight: 8.6 g. Inventory Number: P-51198.
10. A flat base. Reddish-brown pottery tempered with pebble grit and sand. The wall is flat. Dimensions: 28.2 x 27.2 x 9.7 mm. Weight: 11.06 g. Inventory Number: P-51199.
11. A fragment of the vessel wall made in a mold. Black pottery decorated with a slightly protuberant line and underneath it a channel. Dimensions: 25.4 x 24.0 x 4.3 mm. Weight: 2.11 g. Inventory Number: P-51200.

TABLA 4

Probe 2, layer 2

1. An everted rim. Brown pottery on the outside, grey on the inside, tempered with sand. Dimensions: 15.5 x 13.5 x 4.1 mm. Weight: 1.41 g. Inventory Number: P-51314.
2. An everted rim (?). Dark grey pottery on the outside, brown on the inside, tempered with sand. Dimensions: 32.4 x 24.0 x 7.7 mm. Weight: 6.30 g. Inventory Number: P-51393.
3. A flat rim. Flecked (black and brown) pottery on the outside, brown on the inside, tempered with pebble grit. Brushed outer wall surface. Dimensions: 24.2 x

4. Uvučeni obod. Sivosmeđa keramika s primjesama pijeska. Dimenzije: 24,6 x 18,6 x 5,1 mm. Težina: 3,43 g. Inventarni broj: P-51311.
 5. Uvučeni obod. Smeđa keramika s primjesama pijeska. Dimenzije: 23,7 x 23,0 x 7,8 mm. Težina: 4,72 g. Inventarni broj: P-51385.
 6. Izvijeni obod. Tamnosiva keramika s primjesama sitnih kamenčića i pijeska. Glačana vanjska i unutrašnja površina stijenke. Dimenzije: 39,0 x 36,3 x 6,9 mm. Težina: 13,15 g. Inventarni broj: P-51387.
 7. Ravni obod. Tamnosiva keramika s primjesama pijeska. Glačana vanjska i unutrašnja površina stijenke. Dimenzije: 31,0 x 24,5 x 8,0 mm. Težina: 8,86 g. Inventarni broj: P-51313.
 8. Izvijeni obod. Siva keramika s primjesama pijeska. Dimenzije: 42,2 x 36,1 x 6,3 mm. Težina: 13,36 g. Inventarni broj: P-51322.
 9. Uvučeni obod. Smeđa keramika s primjesama sitnih kamenčića. Metličasto ukrašena vanjska i unutrašnja površina stijenke. Dimenzije: 36,1 x 35,9 x 5,4 mm. Težina: 8,96 g. Inventarni broj: P-51389.
 10. Izvijeni obod. Crna keramika s primjesama pijeska. Glačana vanjska i unutrašnja površina stijenke. Dimenzije: 59,9 x 40,7 x 6,3 mm. Težina: 20,68 g. Inventarni broj: P-51388.
 11. Izvijeni obod. Tamnosmeđa keramika s primjesama sitnih kamenčića. Glačana vanjska i unutrašnja površina stijenke. Dimenzije: 87,8 x 33,7 x 6,2 mm. Težina: 26,7 g. Inventarni broj: P-51387.
 12. Izvijeni obod. Izvana crna, iznutra mrljasta (crna i smeđa) keramika s primjesama sitnih kamenčića i pijeska. Glačana vanjska i unutrašnja površina stijenke na crnim dijelovima. Ispod vrata nalazi se ukras u vidu okomitih, međusobno paralelnih i gusto posloženih plitkih kanelura. Dimenzije: 76,0 x 66,2 x 5,9 mm. Težina: 36,85 g. Inventarni broj: P-51324.
 13. Izvijeni obod. Izvana i iznutra mrljasta (smeđa i tamnosiva) keramika s primjesama pijeska. Glačane vanjska i unutrašnja površina stijenke. Dimenzije: 177,9 x 69,5 x 8,7 mm. Težina: 157,79 g. Inventarni broj: P-51310.
 14. Uvučeni obod. Na usni ukrašen utiscima nekim predmetom. Izvana i iznutra crvenkastosmeđa, a na usni oboda crna keramika s primjesama sitnih kamenčića i pijeska. Dimenzije: 27,0 x 19,3 x 6,9 mm. Težina: 4,57 g. Inventarni broj: P-51315.
 15. Ravni obod. Na usni ukrašen utiscima nekim predmetom. Tamnosiva keramika s primjesama pijeska. Metličasto obrađena vanjska i unutrašnja površina stijenke. Dimenzije: 35,7 x 15,7 x 5,8 mm. Težina: 4,14 g. Inventarni broj: P-51323.
- 19.3 x 5.9 mm. Weight: 2.97 g. Inventory Number: P-51312.
 4. A drawn in rim. Grey-brown pottery tempered with sand. Dimensions: 24.6 x 18.6 x 5.1 mm. Weight: 3.43 g. Inventory Number: P-51311.
 5. A drawn in rim. Brown pottery tempered with sand. Dimensions: 23.7 x 23.0 x 7.8 mm. Weight: 4.72 g. Inventory Number: P-51385.
 6. An everted rim. Dark grey pottery tempered with pebble grit and sand. Burnished outer and inner wall surface. Dimensions: 39.0 x 36.3 x 6.9 mm. Weight: 13.15 g. Inventory Number: P-51387.
 7. A flat rim. Dark grey pottery tempered with sand. Burnished outer and inner wall surface. Dimensions: 31.0 x 24.5 x 8.0 mm. Weight: 8.86 g. Inventory Number: P-51313.
 8. An everted rim. Grey pottery tempered with sand. Dimensions: 42.2 x 36.1 x 6.3 mm. Weight: 13.36 g. Inventory Number: P-51322.
 9. A drawn in rim. Brown pottery tempered with pebble grit. Brushed outer and inner wall surface. Dimensions: 36.1 x 35.9 x 5.4 mm. Weight: 8.96 g. Inventory Number: P-51389.
 10. An everted rim. Black pottery tempered with sand. Burnished outer and inner wall surface. Dimensions: 59.9 x 40.7 x 6.3 mm. Weight: 20.68 g. Inventory Number: P-51388.
 11. An everted rim. Dark brown pottery tempered with pebble grit. Burnished outer and inner wall surface. Dimensions: 87.8 x 33.7 x 6.2 mm. Weight: 26.7 g. Inventory Number: P-51387.
 12. An everted rim. Black pottery on the outside, flecked (black and brown) on the inside, tempered with pebble grit and sand. On the black sections, a burnished outer and inner wall surface. Located underneath the neck is a decoration consisting of vertical, mutually parallel and densely set shallow channels. Dimensions: 76.0 x 66.2 x 5.9 mm. Weight: 36.85 g. Inventory Number: P-51324.
 13. An everted rim. Flecked (brown and dark grey) pottery both on the outside and inside, tempered with sand. Burnished outer and inner wall surface. Dimensions: 177.9 x 69.5 x 8.7 mm. Weight: 157.79 g. Inventory Number: P-51310.
 14. A drawn in rim. The lip decorated with impressions made by an unidentified object. Reddish-brown pottery on the exterior and interior, black pottery on the lip of the rim, tempered with pebble grit and sand. Dimensions: 27.0 x 19.3 x 6.9 mm. Weight: 4.57 g. Inventory Number: P-51315.
 15. A flat rim. The lip decorated with impressions made by an unidentified object. Dark grey pottery tempered with sand. Brushed outer and inner wall

16. Ravni obod. Na usni ukrašen utiscima nekim predmetom. Smeđa keramika s primjesama sitnih kamenčića i pijeska. Metličasto obrađena vanjska i unutrašnja površina stijenke. Dimenzije: 39,9 x 30,0 x 5,4 mm. Težina: 8,39 g. Inventarni broj: P-51318.

TABLA 5

Sonda 2, sloj 2

1. Izvijeni obod. Usna ukrašena otiscima prsta. Žuta keramika s primjesama sitnih kamenčića. Dimenzije: 43,0 x 22,1 x 7,8 mm. Težina: 10,15 g. Inventarni broj: P-51317.
2. Uvučeni obod. Usna ukrašena utiscima noktom. Smeđa keramika s primjesama sitnih kamenčića. Metličasto obrađena vanjska površina stijenke. Dimenzije: 39,0 x 23,8 x 5,9 mm. Težina: 7,71 g. Inventarni broj: P-51390.
3. Izvijeni obod. Usna ukrašena utiscima noktom. Smeđa keramika s primjesama sitnih kamenčića. Metličasto obrađena vanjska površina stijenke. Dimenzije: 62,4 x 47,3 x 8,2 mm. Težina: 32,93 g. Inventarni broj: P-51319.
4. Uvučeni obod. Usna ukrašena utiscima noktom. Smeđa keramika s primjesama pijeska. Metličasto obrađena vanjska površina stijenke. Dimenzije: 64,4 x 47,9 x 5,5 mm. Težina: 25,26 g. Inventarni broj: P-51316.
5. Izvijeni obod. Usna ukrašena utiscima nekim predmetom. Siva keramika s primjesama pijeska. Metličasto ukrašen jedan dio vanjske stijenke. Ispod vrata nalazi se ukras u vidu jednog reda utisaka nekim predmetom. Dimenzije: 32,2 x 28,1 x 7,8 mm. Težina: 10,45 g. Inventarni broj: P-51320.
6. Izrazito izvijeni obod. Uz samu usnu oboda na unutrašnjem dijelu stijenke ukras u vidu utisaka nekim predmetom, koji slijedi liniju oboda. Smeđa keramika s primjesama pijeska. Na donjem dijelu ulomka nalazi se ukras - dva paralelna, vodoravna reda utisaka nekim predmetom. Dimenzije: 72,4 x 46,0 x 6,3 mm. Težina: 31,28 g. Inventarni broj: P-51391.
7. Uvučeni obod, na jednom dijelu jezičasto izvijen prema van. Na ulomku je očuvana cijela vodoravno postavljena tunelasta ručkica. Crvenkastosmeđa keramika s primjesama sitnih kamenčića i pijeska. Između usne i ručkice nalazi se ukras - dvije paralelne linije gusto raspoređenih uboda. Linije se kreću cik-cak. U nekim ubodima sačuvana je

surface. Dimensions: 35.7 x 15.7 x 5.8 mm. Weight: 4.14 g. Inventory Number: P-51323.

16. A flat rim. The lip is decorated with impressions made with an unidentified object. Brown pottery tempered with pebble grit and sand. Brushed outer and inner wall surface. Dimensions: 39.9 x 30.0 x 5.4 mm. Weight: 8.39 g. Inventory Number: P-51318.

TABLA 5

Probe 2, layer 2

1. An everted rim. The lip is decorated with finger impressions. Yellow pottery tempered with pebble grit. Dimensions: 43.0 x 22.1 x 7.8 mm. Weight: 10.15 g. Inventory Number: P-51317.
2. A drawn in rim. The lip is decorated with nail impressions. Brown pottery tempered with pebble grit. Brushed outer wall surface. Dimensions: 39.0 x 23.8 x 5.9 mm. Weight: 7.71 g. Inventory Number: P-51390.
3. An everted rim. The lip is decorated with nail impressions. Brown pottery tempered with pebble grit. Brushed outer wall surface. Dimensions: 62.4 x 47.3 x 8.2 mm. Weight: 32.93 g. Inventory Number: P-51319.
4. A drawn in rim. The lip is decorated with nail impressions. Brown pottery tempered with sand. Brushed outer wall surface. Dimensions: 64.4 x 47.9 x 5.5 mm. Weight: 25.26 g. Inventory Number: P-51316.
5. An everted rim. The lip is decorated with impressions made with an unidentified object. Grey pottery tempered with sand. A section of the outer wall is brushed. Located underneath the neck is a decoration consisting of a single row of impressions made with an unidentified object. Dimensions: 32.2 x 28.1 x 7.8 mm. Weight: 10.45 g. Inventory Number: P-51320.
6. A particularly everted rim. Located along the lip of the rim on the interior section of the wall is a decoration consisting of impressions made with an unidentified object, which follow the line of the rim. Brown pottery tempered with sand. Located on the lower section of the fragment is a decoration consisting of two parallel, horizontal rows of impressions made with an unidentified object. Dimensions: 72.4 x 46.0 x 6.3 mm. Weight: 31.28 g. Inventory Number: P-51391.
7. A drawn in rim, in one section it is everted towards the outside in a linguiform manner. Preserved on the fragment is an entire horizontally placed tunnel-handle. Reddish-brown pottery tempered with pebble grit and sand. Located between the

bijela inkrustacija. Dimenzije: 53,9 x 35,1 x 6,0 mm. Težina: 14,57 g. Inventarni broj: P-51334.

8. Izvijeni obod. Na usni ukrašen utiscima nekim predmetom. Izvana tamnosiva, iznutra mrljasta (tamnosiva i smeđa) keramika s primjesama sitnih kamenčića i pijeska. Ispod usne nalazi se plastična traka s utiscima nekim predmetom. Dimenzije: 76,6 x 59,6 x 9,8 mm. Težina: 58,24 g. Inventarni broj: P-51321.
9. Zaobljeno dno. Siva keramika s primjesama pijeska. Stijenka nije očuvana. Dimenzije: 58,0 x 37,9 x 8,3 mm. Težina: 20,41 g. Inventarni broj: P-51329.
10. Zaobljeno dno. Izvana tamnosiva, iznutra smeđa keramika s primjesama sitnih kamenčića. Stijenka nije očuvana. Dimenzije: 56,1 x 41,0 x 8,4 mm. Težina: 21,92 g. Inventarni broj: P-51392.
11. Ravno dno. Siva keramika, glačana izvana. Stijenka je blago izvijena prema van. Dimenzije: 46,8 x 35,0 x 4,7 mm. Težina 12,63 g. Inventarni broj: P-51328.
12. Ravno dno. Smeđa keramika s primjesama sitnih kamenčića i pijeska. Metličasto obrađena vanjska površina stijenke. Stijenka je ravna. Dimenzije: 51,7 x 43,9 x 12,0 mm. Težina: 33,85 g. Inventarni broj: P-51326.

TABLA 6

Sonda 2, sloj 2

1. Ravno dno na peticu. Smeđa keramika s primjesama sitnih kamenčića i pijeska. Stijenka je izvijena prema van. Dimenzije: 56,3 x 32,3 x 9,6 mm. Težina: 19,49 g. Inventarni broj: P-51328.
2. Ravno dno. Siva keramika s primjesama sitnih kamenčića i pijeska. Stijenka je ravna. Dimenzije: 56,0 x 36,6 x 5,8 mm. Težina: 21,26 g. Inventarni broj: P-51325.
3. Ravno dno široke zdjele. Izvana mrljasta (smeđa i tamnosiva), iznutra smeđa keramika s primjesama sitnih kamenčića i pijeska. Glačana vanjska površina stijenke. Stijenka je ravna. Dimenzije: 56,3 x 47,2 x 7,8 mm. Težina: 30,23 g. Inventarni broj: P-51330.
4. Ulomak ručkice. Smeđa keramika. Izvana glačana. Dimenzije: 23,2 x 15,3 x 4,7 mm. Težina: 2,92 g. Inventarni broj: P-51335.
5. Ulomak stijenke posude s izbočinom (možda početak ručke?). Izvana mrljasta (tamnosiva i smeđa), iznutra smeđa keramika. Na izbočini se nalazi nekoliko utisaka noktom. Dimenzije: 47,2 x 35,7 x 11,5 mm. Težina: 22,54 g. Inventarni broj: P-51338.

lip and the handle is a decoration consisting of two parallel lines of densely arranged engraved points. The lines are zigzag. In some engraved points a white incrustation is preserved. Dimensions: 53.9 x 35.1 x 6.0 mm. Weight: 14.57 g. Inventory Number: P-51334.

8. An everted rim. The lip is decorated with impressions made with an unidentified object. Dark grey pottery on the outside, flecked (dark grey and brown) on the inside, tempered with pebble grit and sand. Located underneath the lip is a plastic strap with impressions made with an unidentified object. Dimensions: 76.6 x 59.6 x 9.8 mm. Weight: 58.24 g. Inventory Number: P-51321.
9. A rounded base. Grey pottery tempered with sand. The wall is not preserved. Dimensions: 58.0 x 37.9 x 8.3 mm. Weight: 20.41 g. Inventory Number: P-51329.
10. A rounded base. Dark grey pottery on the outside, brown on the inside, tempered with pebble grit. The wall is not preserved. Dimensions: 56.1 x 41.0 x 8.4 mm. Weight: 21.92 g. Inventory Number: P-51392.
11. A flat base. Grey pottery, burnished on the outside. The wall is slightly everted towards the outside. Dimensions: 46.8 x 35.0 x 4.7 mm. Weight 12.63 g. Inventory Number: P-51328.
12. A flat base. Brown pottery tempered with pebble grit and sand. Brushed outer wall surface. The wall is flat. Dimensions: 51.7 x 43.9 x 12,0 mm. Weight: 33.85 g. Inventory Number: P-51326.

TABLA 6

Probe 2, layer 2

1. A flat heel-base. Brown pottery tempered with pebble grit and sand. The wall is everted towards the outside. Dimensions: 56.3 x 32.3 x 9.6 mm. Weight: 19.49 g. Inventory Number: P-51328.
2. A flat base. Grey pottery tempered with pebble grit and sand. The wall is flat. Dimensions: 56.0 x 36.6 x 5.8 mm. Weight: 21.26 g. Inventory Number: P-51325.
3. A flat base of a broad bowl. Flecked (brown and dark grey) pottery on the outside, brown on the inside, tempered with pebble grit and sand. Burnished outer wall surface. The wall is flat. Dimensions: 56.3 x 47.2 x 7.8 mm. Weight: 30.23 g. Inventory Number: P-51330.
4. A fragment of a small handle. Brown pottery. Burnished on the outside. Dimensions: 23.2 x 15.3 x 4.7 mm. Weight: 2.92 g. Inventory Number: P-51335.
5. A fragment of the vessel wall with a protuberance (perhaps the beginning of a handle?). Flecked (dark

6. Ulomak stijenke posude s nedovršenom rupicom za krpanje. Smeđa keramika s primjesama pijeska. Dimenzije: 41,5 x 36,0 x 6,5 mm. Težina: 13,28 g. Inventarni broj: P-51331.
 7. Ulomak stijenke posude s dijelom rupice za krpanje. Siva keramika s primjesama pijeska. Dimenzije: 27,8 x 24,1 x 7,6 mm. Težina: 6,25 g. Inventarni broj: P-51333.
 8. Ulomak stijenke posude s vidljivim dijelom rupice za krpanje. Žuta keramika. Glačana vanjska i unutrašnja površina stijenke. Dimenzije: 34,5 x 28,8 x 5,2 mm. Težina: 5,44 g. Inventarni broj: P-51395.
 9. Ulomak stijenke posude s rupicom za krpanje. Izvana tamnosiva, iznutra smeđa keramika s primjesama sitnih kamenčića i pijeska. Metličasto obrađena vanjska površina stijenke. Dimenzije: 39,5 x 34,3 x 6,9 mm. Težina: 11,32 g. Inventarni broj: P-51394.
 10. Ulomak stijenke posude s rupicom za krpanje. Mrljasta (tamnosiva i smeđa) keramika s primjesama sitnih kamenčića i pijeska. Metličasto obrađena vanjska površina stijenke. Dimenzije: 102,2 x 72,3 x 6,2 mm. Težina: 6,25 g. Inventarni broj: P-51333.
 11. Ulomak stijenke male posude. Izvana siva, iznutra mrljasta (siva i smeđa) keramika. Ulomak ukrašen tanko urezanim nepravilnim linijama. Dimenzije: 34,6 x 29,0 x 6,3 mm. Težina: 9,49 g. Inventarni broj: P-51336.
 12. Ulomak stijenke posude. Crna keramika. Glačana vanjska površina stijenke. Ulomak ukrašen s tri urezane paralelne, blago zakrivljene linije. Dimenzije: 40,0 x 21,7 x 6,7 mm. Težina: 5,25 g. Inventarni broj: P-51337.
 13. Ulomak trbuha i vrata posude. Izvana glačana, crna keramika s primjesama sitnih kamenčića. Dimenzije: 75,6 x 32,5 x 8,8 mm. Težina: 21,41 g. Inventarni broj: P-51396.
- grey and brown) pottery on the outside, brown on the inside. Located on the protuberance are several nail impressions. Dimensions: 47.2 x 35.7 x 11.5 mm. Weight: 22.54 g. Inventory Number: P-51338.
6. A fragment of the vessel wall with an unfinished perforation used for mending. Brown pottery tempered with sand. Dimensions: 41.5 x 36.0 x 6.5 mm. Weight: 13.28 g. Inventory Number: P-51331.
 7. A fragment of the vessel wall with part of a perforation used for mending. Grey pottery tempered with sand. Dimensions: 27.8 x 24.1 x 7.6 mm. Weight: 6.25 g. Inventory Number: P-51333.
 8. A fragment of the vessel wall, a section of the perforation used for mending is visible. Yellow pottery. Burnished outer and inner wall surface. Dimensions: 34.5 x 28.8 x 5.2 mm. Weight: 5.44 g. Inventory Number: P-51395.
 9. A fragment of the vessel wall with a perforation used for mending. Dark grey pottery on the outside, brown on the inside, tempered with pebble grit and sand. Brushed outer wall surface. Dimensions: 39.5 x 34.3 x 6.9 mm. Weight: 11.32 g. Inventory Number: P-51394.
 10. A fragment of the vessel wall with a perforation used for mending. Flecked (dark grey and brown) pottery tempered with pebble grit and sand. Brushed outer wall surface. Dimensions: 102.2 x 72.3 x 6.2 mm. Weight: 6.25 g. Inventory Number: P-51333.
 11. A fragment of the small vessel wall. Grey pottery on the outside, flecked (grey and brown) on the inside. The fragment is decorated with shallow incised irregular lines. Dimensions: 34.6 x 29.0 x 6.3 mm. Weight: 9.49 g. Inventory Number: P-51336.
 12. A fragment of the vessel wall. Black pottery. Burnished outer wall surface. The fragment is decorated with three incised, parallel, slightly bent lines. Dimensions: 40.0 x 21.7 x 6.7 mm. Weight: 5.25 g. Inventory Number: P-51337.
 13. A fragment of the belly and neck of a vessel. Burnished on the outside, black pottery tempered with pebble grit. Dimensions: 75.6 x 32.5 x 8.8 mm. Weight: 21.41 g. Inventory Number: P-51396.

TABLE 7

Sonda 2, sloj 2

1. Ulomak trbuha i vrata posude. Izvana glačana, tamnosmeđa keramika s primjesama sitnih kamenčića. Na mjestu prelaska iz trbuha u vrat nalazi se nekoliko ukošenih, kaneliranih, izrazito plitkih i jedva vidljivih paralelnih linija koje prate liniju trbuha. Dimenzije: 108,9 x 77,4 x 7,0 mm. Težina: 62,98 g. Inventarni broj: P-51397.

TABLE 7

Probe 2, layer 2

1. A fragment of the belly and neck of a vessel. Burnished on the outside, dark brown pottery tempered with pebble grit. At the transition of the belly to the neck are several slanted, cannulated, distinctly shallow and barely visible parallel lines that follow the line of the belly. Dimensions: 108.9 x 77.4 x 7.0 mm. Weight: 62.98 g. Inventory Number: P-51397.

Sonda 2, tvorevina 1B

2. Uvučeni obod. Izvana mrljasta (siva i žuta), iznutra tamnosiva keramika s primjesama sitnih kamenčića. Dimenzije: 70,6 x 48,3 x 7,3 mm. Težina: 32,01 g. Inventarni broj: P-51118.

Sonda 2, tvorevina 2B

3. Izvijeni obod. Izvana žuta, iznutra siva keramika s primjesama pijeska. Dimenzije: 60,2 x 33,0 x 7,0 mm. Težina: 24,2 g. Inventarni broj: P-51349.
4. Uvučeni obod. Siva keramika s primjesama sitnih kamenčića i pijeska. Ispod usne nalazi se plastična traka s utiscima prsta. Dimenzije: 69,1 x 46,2 x 9,5 mm. Težina: 41,03 g. Inventarni broj: P-51350.
5. Donji rub perforirane posude – cjedila. Smeđa keramika s primjesama pijeska. Dimenzije: 30,6 x 18,3 x 8,0 mm. Težina: 5,98 g. Inventarni broj: P-51351.

Sonda 2, tvorevina 3

6. Ravni obod. Smeđa keramika s primjesama sitnih kamenčića i pijeska. Dimenzije: 27,3 x 21,4 x 6,3 mm. Težina: 4,43 g. Inventarni broj: P-51211.
7. Izrazito izvijeni obod. Crna keramika, glačana izvana i iznutra. Dimenzije: 29,2 x 20,9 x 4,0 mm. Težina: 5,73 g. Inventarni broj: P-51209.
8. Izvijeni obod. Siva keramika s primjesama pijeska. Dimenzije: 30,0 x 20,8 x 5,6 mm. Težina: 5,42 g. Inventarni broj: P-51207.
9. Izvijeni obod. Žuta keramika s primjesama sitnih kamenčića i pijeska. Glačana vanjska površina stijenke. Dimenzije: 25,2 x 20,0 x 5,8 mm. Težina: 4,04 g. Inventarni broj: P-51354.
10. Ravni obod. Smeđa keramika s primjesama pijeska. Metličasto obrađena vanjska površina stijenke. Dimenzije: 32,4 x 24,4 x 5,5 mm. Težina: 6,03 g. Inventarni broj: P-51355.
11. Uvučeni obod. Siva keramika s primjesama sitnih kamenčića i pijeska. Metličasto obrađena vanjska površina stijenke. Dimenzije: 28,8 x 23,1 x 7,0 mm. Težina: 7,23 g. Inventarni broj: P-51357.
12. Izvijeni obod. Izvana žuta, iznutra siva keramika s primjesama sitnih kamenčića i pijeska. Glačana vanjska površina stijenke. Dimenzije: 35,2 x 32,9 x 8,8 mm. Težina: 10,48 g. Inventarni broj: P-51181.
13. Izvijeni obod. Izvana crna, iznutra smeđa keramika s primjesama sitnih kamenčića i pijeska. Dimenzije: 40,0 x 33,4 x 6,6 mm. Težina: 11,72 g. Inventarni broj: P-51182.
14. Izvijeni obod. Žuta keramika s primjesama sitnih kamenčića i pijeska. Glačana vanjska i unutrašnja

Probe 2, feature 1B

2. A drawn in rim. Flecked (grey and yellow) pottery on the outside, dark grey on the inside, tempered with pebble grit. Dimensions: 70.6 x 48.3 x 7.3 mm. Weight: 32.01 g. Inventory Number: P-51118.

Probe 2, feature 2B

3. An everted rim. Yellow pottery on the outside, grey on the inside, tempered with sand. Dimensions: 60.2 x 33.0 x 7.0 mm. Weight: 24.2 g. Inventory Number: P-51349.
4. A drawn in rim. Grey pottery tempered with pebble grit and sand. Located underneath the lip is a plastic strap with finger impressions. Dimensions: 69.1 x 46.2 x 9.5 mm. Weight: 41.03 g. Inventory Number: P-51350.
5. The lower edge of a perforated vessel – sieve. Brown pottery tempered with sand. Dimensions: 30.6 x 18.3 x 8.0 mm. Weight: 5.98 g. Inventory Number: P-51351.

Probe 2, feature 3

6. A flat rim. Brown pottery tempered with pebble grit and sand. Dimensions: 27.3 x 21.4 x 6.3 mm. Weight: 4.43 g. Inventory Number: P-51211.
7. A particularly everted rim. Black pottery, burnished both on the outside and inside. Dimensions: 29.2 x 20.9 x 4.0 mm. Weight: 5.73 g. Inventory Number: P-51209.
8. An everted rim. Grey pottery tempered with sand. Dimensions: 30.0 x 20.8 x 5.6 mm. Weight: 5.42 g. Inventory Number: P-51207.
9. An everted rim. Yellow pottery tempered with pebble grit and sand. Burnished outer wall surface. Dimensions: 25.2 x 20.0 x 5.8 mm. Weight: 4.04 g. Inventory Number: P-51354.
10. A flat rim. Brown pottery tempered with sand. Brushed outer wall surface. Dimensions: 32.4 x 24.4 x 5.5 mm. Weight: 6.03 g. Inventory Number: P-51355.
11. A drawn in rim. Grey pottery tempered with pebble grit and sand. Brushed outer wall surface. Dimensions: 28.8 x 23.1 x 7.0 mm. Weight: 7.23 g. Inventory Number: P-51357.
12. An everted rim. Yellow pottery on the outside, grey on the inside, tempered with pebble grit and sand. Burnished outer wall surface. Dimensions: 35.2 x 32.9 x 8.8 mm. Weight: 10.48 g. Inventory Number: P-51181.
13. An everted rim. Black pottery on the outside, brown on the inside, tempered with pebble grit and sand. Dimensions: 40.0 x 33.4 x 6.6 mm. Weight: 11.72 g. Inventory Number: P-51182.

površina stijenke. Dimenzije: 38,0 x 27,8 x 7,7 mm. Težina: 9,86 g. Inventarni broj: P-51210.

15. Uvučeni obod. Siva keramika s primjesama sitnih kamenčića i pijeska. Dimenzije: 46,2 x 37,5 x 6,9 mm. Težina: 16,49 g. Inventarni broj: P-51356.

TABLA 8

Sonda 2, tvorevina 3

1. Uvučeni obod. Izvana siva, iznutra smeđa keramika s primjesama sitnih kamenčića i pijeska. Dimenzije: 40,8 x 36,6 x 7,3 mm. Težina: 16,06 g. Inventarni broj: P-51352.
2. Ravni obod. Izvana siva, iznutra mrljasta (siva i smeđa) keramika s primjesama sitnih kamenčića i pijeska. Glačana unutrašnja površina stijenke. Dimenzije: 60,1 x 49,4 x 8,0 mm. Težina: 34,69 g. Inventarni broj: P-51353.
3. Izvijeni obod. Tamnosiva keramika s primjesama pijeska. Metličasto obrađena vanjska površina stijenke. Ispod oboda nalaze se tri utiska noktom, paralelna s linijom oboda. Dimenzije: 49,3 x 44,4 x 4,9 mm. Težina: 11,2 g. Inventarni broj: P-51366.
4. Uvučeni obod. Crna keramika s primjesama sitnih kamenčića i pijeska. Glačana vanjska i unutrašnja površina stijenke. Dimenzije: 56,3 x 44,5 x 6,4 mm. Težina: 26,72 g. Inventarni broj: P-51208.
5. Uvučeni obod. Mrljasta (siva i smeđa) keramika s primjesama sitnih kamenčića i pijeska. Ispod oboda ukras u vidu plitkih utisaka nekim predmetom. Dimenzije: 48,1 x 43,0 x 6,3 mm. Težina: 16,98 g. Inventarni broj: P-51213.
6. Izvijeni obod. Mrljasta (tamnosiva i smeđa) keramika s primjesama sitnih kamenčića i pijeska. Glačana vanjska površina stijenke. Dimenzije: 72,9 x 42,0 x 6,7 mm. Težina: 32,06 g. Inventarni broj: P-51183.
7. Izvijeni obod. Izvana smeđa, iznutra siva keramika s primjesama sitnih kamenčića i pijeska. Ispod usne nalazi se plastična traka s utiscima prstom. Dimenzije: 63,7 x 54,1 x 11,8 mm. Težina: 52,0 g. Inventarni broj: P-51186.
8. Ravni obod. Na usni ukrašen utiscima noktom. Smeđa keramika s primjesama sitnih kamenčića i pijeska. Metličasto obrađena vanjska površina stijenke. Dimenzije: 38,0 x 28,1 x 7,2 mm. Težina: 11,1 g. Inventarni broj: P-51212.
9. Uvučeni obod. Usna oboda ukrašena utiscima noktom. Smeđa keramika s primjesama sitnih kamenčića i pijeska. Dimenzije: 41,0 x 28,5 x 5,5 mm. Težina: 9,16 g. Inventarni broj: P-51359.
10. Uvučeni obod. Usna oboda ukrašena utiscima noktom. Izvana mrljasta (smeđa i tamnosiva),

14. An everted rim. Yellow pottery tempered with pebble grit and sand. Burnished outer and inner wall surface. Dimensions: 38.0 x 27.8 x 7.7 mm. Weight: 9.86 g. Inventory Number: P-51210.

15. A drawn in rim. Grey pottery tempered with pebble grit and sand. Dimensions: 46.2 x 37.5 x 6.9 mm. Weight: 16.49 g. Inventory Number: P-51356.

TABLA 8

Probe 2, feature 3

1. A drawn in rim. Grey pottery on the outside, brown on the inside, tempered with pebble grit and sand. Dimensions: 40.8 x 36.6 x 7.3 mm. Weight: 16.06 g. Inventory Number: P-51352.
2. A flat rim. Grey pottery on the outside, flecked (grey and brown) on the inside, tempered with pebble grit and sand. Burnished inner wall surface. Dimensions: 60.1 x 49.4 x 8.0 mm. Weight: 34.69 g. Inventory Number: P-51353.
3. An everted rim. Dark grey pottery tempered with sand. Brushed outer wall surface. Located underneath the rim are three nail impressions that run parallel with the line of the rim. Dimensions: 49.3 x 44.4 x 4.9 mm. Weight: 11.2 g. Inventory Number: P-51366.
4. A drawn in rim. Black pottery tempered with pebble grit and sand. Burnished outer and inner wall surface. Dimensions: 56.3 x 44.5 x 6.4 mm. Weight: 26.72 g. Inventory Number: P-51208.
5. A drawn in rim. Flecked (grey and brown) pottery tempered with pebble grit and sand. Located underneath the rim is a decoration consisting of shallow impressions made with an unidentified object. Dimensions: 48.1 x 43.0 x 6.3 mm. Weight: 16.98 g. Inventory Number: P-51213.
6. An everted rim. Flecked (dark grey and brown) pottery tempered with pebble grit and sand. Burnished outer wall surface. Dimensions: 72.9 x 42.0 x 6.7 mm. Weight: 32.06 g. Inventory Number: P-51183.
7. An everted rim. Brown pottery on the outside, grey on the inside, tempered with pebble grit and sand. Located underneath the lip is a plastic strap with finger impressions. Dimensions: 63.7 x 54.1 x 11.8 mm. Weight: 52.0 g. Inventory Number: P-51186.
8. A flat rim. The lip is decorated with nail impressions. Brown pottery tempered with pebble grit and sand. Brushed outer wall surface. Dimensions: 38.0 x 28.1 x 7.2 mm. Weight: 11.1 g. Inventory Number: P-51212.
9. A drawn in rim. The lip of the rim is decorated with nail impressions. Brown pottery tempered with pebble grit and sand. Dimensions: 41.0 x 28.5 x 5.5 mm. Weight: 9.16 g. Inventory Number: P-51359.

iznutra tamnosiva keramika s primjesama pijeska. Metličasto obrađena vanjska površina stijenke. Dimenzije: 46,7 x 38,7 x 7,0 mm. Težina: 15,74 g. Inventarni broj: P-51360.

11. Izvijeni obod. Usna oboda ukrašena utiscima noktom. Izvana tamnosiva, iznutra smeđa keramika s primjesama sitnih kamenčića i pijeska. Metličasto obrađena vanjska površina stijenke. Dimenzije: 50,5 x 27,0 x 5,3 mm. Težina: 11,96 g. Inventarni broj: P-51363.
12. Uvučeni obod. Usna oboda ukrašena utiscima noktom. Žutosmeđa keramika s primjesama pijeska. Metličasto obrađena vanjska površina stijenke. Dimenzije: 56,5 x 36,7 x 6,8 mm. Težina: 18,28 g. Inventarni broj: P-51362.

TABLA 9

Sonda 2, tvorevina 3

1. Izvijeni obod. Usna oboda ukrašena utiscima noktom. Mrljasta (tamnosiva i smeđa) keramika s primjesama pijeska. Metličasto obrađena vanjska i unutrašnja površina stijenke. Dimenzije: 48,4 x 40,2 x 8,9 mm. Težina: 29,66 g. Inventarni broj: P-51358.
2. Uvučeni obod. Usna oboda s vanjske strane zadebljana. Zadebljanje je ukrašeno utiscima prstom tako da tvori valovit ukras. Smeđa keramika s primjesama sitnih kamenčića. Na donjem dijelu ulomka nalaze se dva utiska prstom. Dimenzije: 86,0 x 50,4 x 8,1 mm. Težina: 45,31 g. Inventarni broj: P-51365.
3. Uvučeni obod. Usna oboda ukrašena utiscima noktom. Smeđa keramika s primjesama pijeska. Metličasto obrađena vanjska i unutrašnja površina stijenke. Dimenzije: 64,7 x 53,0 x 5,5 mm. Težina: 32,65 g. Inventarni broj: P-51361.
4. Uvučeni obod. Usna ukrašena utiscima noktom. Izvana mrljasta (tamnosiva i smeđa), iznutra siva keramika s primjesama sitnih kamenčića i pijeska. Dimenzije: 87,4 x 49,7 x 7,5 mm. Težina: 48,74 g. Inventarni broj: P-51184.
5. Uvučeni obod. Usna ukrašena utiscima noktom. Izvana mrljasta (tamnosiva i smeđa), iznutra siva keramika s primjesama sitnih kamenčića i pijeska. Dimenzije: 147,0 x 83,7 x 7,0 mm. Težina: 87,52 g. Inventarni broj: P-51185.

TABLA 10

Sonda 2, tvorevina 3

1. Izvijeni obod. Mrljasta (crvenkastosmeđa i tamnosiva) keramika s primjesama sitnih kamenčića

10. A drawn in rim. The lip of the rim is decorated with nail impressions. Flecked (brown and dark grey) pottery on the outside, dark grey on the inside, tempered with sand. Brushed outer wall surface. Dimensions: 46.7 x 38.7 x 7.0 mm. Weight: 15.74 g. Inventory Number: P-51360.
11. An everted rim. The lip of the rim is decorated with nail impressions. Dark grey pottery on the outside, brown on the inside, tempered with pebble grit and sand. Brushed outer wall surface. Dimensions: 50.5 x 27.0 x 5.3 mm. Weight: 11.96 g. Inventory Number: P-51363.
12. A drawn in rim. The lip of the rim is decorated with nail impressions. Yellow-brown pottery tempered with sand. Brushed outer wall surface. Dimensions: 56.5 x 36.7 x 6.8 mm. Weight: 18.28 g. Inventory Number: P-51362.

TABLA 9

Probe 2, feature 3

1. An everted rim. The lip of the rim is decorated with nail impressions. Flecked (dark grey and brown) pottery tempered with sand. Brushed outer and inner wall surface. Dimensions: 48.4 x 40.2 x 8.9 mm. Weight: 29.66 g. Inventory Number: P-51358.
2. A drawn in rim. The lip of the rim thickens on the outer side. This thickening is decorated with finger impressions so as to create a wavy decoration. Brown pottery tempered with pebble grit. Located on the lower section of the fragment are two finger impressions. Dimensions: 86.0 x 50.4 x 8.1 mm. Weight: 45.31 g. Inventory Number: P-51365.
3. A drawn in rim. The lip of the rim is decorated with nail impressions. Brown pottery tempered with sand. Brushed outer and inner wall surface. Dimensions: 64.7 x 53.0 x 5.5 mm. Weight: 32.65 g. Inventory Number: P-51361.
4. A drawn in rim. The lip is decorated with nail impressions. Flecked (dark grey and brown) pottery on the outside, grey on the inside, tempered with pebble grit and sand. Dimensions: 87.4 x 49.7 x 7.5 mm. Weight: 48.74 g. Inventory Number: P-51184.
5. A drawn in rim. The lip is decorated with nail impressions. Flecked (dark grey and brown) pottery on the outside, grey on the inside, tempered with pebble grit and sand. Dimensions: 147.0 x 83.7 x 7.0 mm. Weight: 87.52 g. Inventory Number: P-51185.

TABLA 10

Probe 2, feature 3

1. An everted rim. Flecked (reddish-brown and dark grey) pottery tempered with pebble grit and sand.

- i pijeska. Ispod oboda nalazi se plastična traka bez ukrasa. Dimenzije: 101,7 x 67,3 x 7,5 mm. Težina: 87,13 g. Inventarni broj: P-51214.
2. Uvučeni obod i ravno dno iste posude, koji se ne mogu spojiti. Nađeno je još neodredivih ulomaka iste posude. Izvana mrljasta (smeđa i siva), iznutra siva keramika s primjesama pijeska. Na mjestima glačana vanjska površina stijenke. Stijenka dna je blago izvijena prema van. Dimenzije oboda: 129,3 x 71,4 x 6,0 mm. Težina oboda: 68,68 g. Dimenzije dna: 160,2 x 75,8 x 7,6 mm. Težina dna: 75,5 g. Inventarni broj: P-51188.
 3. Ravno dno. Izvana smeđa, iznutra siva keramika s primjesama sitnih kamenčića. Stijenka je ravna. Dimenzije: 25,2 x 12,8 x 9,6 mm. Težina: 3,19 g. Inventarni broj: P-51367.
 4. Ravno dno. Mrljasta (tamnosiva i smeđa) keramika s primjesama pijeska. Stijenka je ravna. Dimenzije: 26,3 x 22,0 x 9,2 mm. Težina: 7,58 g. Inventarni broj: P-51368.
 5. Ravno dno. Smeđa keramika s primjesama sitnih kamenčića i pijeska. Stijenka je ravna. Dimenzije: 39,4 x 38,6 x 7,6 mm. Težina: 18,3 g. Inventarni broj: P-51369.
 6. Ravno dno. Smeđa keramika s primjesama sitnih kamenčića i pijeska. Stijenka je ravna i metličasto obrađena na vanjskoj površini. Dimenzije: 71,5 x 51,3 x 11,8 mm. Inventarni broj: P-51370.
 7. Ravno dno na peticu. Siva keramika s primjesama pijeska. Stijenka je izvijena prema van. Dimenzije: 59,2 x 59,2 x 8,3 mm. Težina: 41,04 g. Inventarni broj: P-51215.

TABLA 11

Sonda 2, tvorevina 3

1. Ravno dno. Izvana smeđa, iznutra siva keramika s primjesama pijeska. Stijenka je blago konkavna i metličasto obrađena na vanjskoj površini. Dimenzije: 61,2 x 32,8 x 7,0 mm. Težina: 18,15 g. Inventarni broj: P-51217.
2. Ravno dno na peticu. Izvana smeđa, iznutra siva keramika. Stijenka je ravna. Dimenzije: 39,1 x 32,4 x 5,8 mm. Težina: 13,85 g. Inventarni broj: P-51216.
3. Ravno dno na peticu. Mrljasta (smeđa i tamnosiva) keramika. Stijenka je blago konkavna i metličasto obrađena na vanjskoj površini. Dimenzije: 88,5 x 61,9 x 8,4 mm. Težina: 81,57 g. Inventarni broj: P-51371.
4. Ulomak ručke. Siva keramika s primjesama sitnih kamenčića i pijeska. Dimenzije: 34,9 x

Located underneath the rim is a plastic strap without any decoration. Dimensions: 101.7 x 67.3 x 7.5 mm. Weight: 87.13 g. Inventory Number: P-51214.

2. A drawn in rim and the flat base from the same vessel, which cannot be joined. Several other undetermined fragments of the same vessel were discovered. Flecked (brown and grey) pottery on the outside, grey on the inside, tempered with sand. The outer wall surface is partly burnished. The base wall is slightly everted towards the outside. Dimensions of the rim: 129.3 x 71.4 x 6.0 mm. Weight of the rim: 68.68 g. Dimensions of the base: 160.2 x 75.8 x 7.6 mm. Weight of the base: 75.5 g. Inventory Number: P-51188.
3. A flat base. Brown pottery on the outside, grey on the inside, tempered with pebble grit. The wall is flat. Dimensions: 25.2 x 12.8 x 9.6 mm. Weight: 3.19 g. Inventory Number: P-51367.
4. A flat base. Flecked (dark grey and brown) pottery tempered with sand. The wall is flat. Dimensions: 26.3 x 22.0 x 9.2 mm. Weight: 7.58 g. Inventory Number: P-51368.
5. A flat base. Brown pottery tempered with pebble grit and sand. The wall is flat. Dimensions: 39.4 x 38.6 x 7.6 mm. Weight: 18.3 g. Inventory Number: P-51369.
6. A flat base. Brown pottery tempered with pebble grit and sand. The wall is flat and brushed on its outer surface. Dimensions: 71.5 x 51.3 x 11.8 mm. Inventory Number: P-51370.
7. A flat heel-base. Grey pottery tempered with sand. The wall is everted towards the outside. Dimensions: 59.2 x 59.2 x 8.3 mm. Weight: 41.04 g. Inventory Number: P-51215.

TABLA 11

Probe 2, feature 3

1. A flat base. Brown pottery on the outside, grey on the inside, tempered with sand. The wall is slightly concave and brushed on its outer surface. Dimensions: 61.2 x 32.8 x 7.0 mm. Weight: 18.15 g. Inventory Number: P-51217.
2. A flat heel-base. Brown pottery on the outside, grey on the inside. The wall is flat. Dimensions: 39.1 x 32.4 x 5.8 mm. Weight: 13.85 g. Inventory Number: P-51216.
3. A flat heel-base. Flecked (brown and dark grey) pottery. The wall is slightly concave and brushed on its outer surface. Dimensions: 88.5 x 61.9 x 8.4 mm. Weight: 81.57 g. Inventory Number: P-51371.
4. A fragment of a handle. Grey pottery tempered with pebble grit and sand. Dimensions: 34.9 x 22.0 x 11.0

- 22,0 x 11,0 mm. Težina: 13,34 g. Inventarni broj: P-51218.
5. Ulomak trbuha posude s očuvanom okomitom ušicom. Siva keramika s primjesama pijeska. Dimenzije: 51,0 x 32,8 x 6,1 mm. Težina: 20,13 g. Inventarni broj: P-51187.
 6. Ulomak jezičaste ručke. Mrljasta (siva i smeđa) keramika s primjesama sitnih kamenčića i pijeska. Dimenzije: 50,9 x 19,2 x 5,8 mm. Težina: 7,11 g. Inventarni broj: P-51219.
 7. Ulomak stijenke perforirane posude - cjedila. Smeđa keramika. Na nekoliko mjesta s vanjske strane stijenke nalaze se utisci noktom. Dimenzije: 40,3 x 27,0 x 5,7 mm. Težina: 6,71 g. Inventarni broj: P-51373.
 8. Ulomak stijenke posude s dijelom rupice za krpanje. Žuta keramika. Dimenzije: 44,2 x 37,6 x 6,5 mm. Težina: 16,6 g. Inventarni broj: P-51372.
 9. Ulomak stijenke posude s rupicom za krpanje. Tamnosiva keramika s primjesama sitnih kamenčića. Metličasto ukrašena vanjska površina stijenke. Dimenzije: 50,7 x 43,5 x 6,9 mm. Težina: 19,34 g. Inventarni broj: P-51220.
 10. Ulomak stijenke posude s plastičnom trakom ukrašenom utiscima prsta. Siva keramika s primjesama pijeska. Dimenzije: 29,7 x 24,6 x 7,2 mm. Težina: 8,78 g. Inventarni broj: P-51364.
 11. Ulomak stijenke posude. Žuta keramika, glačana izvana. Ukrašena s pet plitkih, relativno paralelnih kanelura. Dimenzije: 30,2 x 24,4 x 5,7 mm. Težina: 7,37 g. Inventarni broj: P-51221.
 12. Ulomak vrata i trbuha posude. Siva keramika s primjesama pijeska. Na truhu je traka s ukošenim, udubljenim crtama. Dimenzije: 43,8 x 25,3 x 5,7 mm. Težina: 9,06 g. Inventarni broj: P-51222.
 13. Fragment jednog kraja pintadere po kojem se može pretpostaviti da je bila pravokutnog oblika. Mrljasta (žuta, crvenkasta i tamnosiva) keramika s primjesama kamenčića i pijeska. Ukrašena je duboko urezanim paralelnim cik-cak linijama unutar kojih se mogu vidjeti naznake crvene boje. Dimenzije: 32,5 x 31,3 x 12,5 mm. Težina: 15,5 g. Inventarni broj: P-51374.
- mm. Weight: 13.34 g. Inventory Number: P-51218.
5. A fragment of the belly of a vessel with a preserved vertical lug. Grey pottery tempered with sand. Dimensions: 51.0 x 32.8 x 6.1 mm. Weight: 20.13 g. Inventory Number: P-51187.
 6. A fragment of a linguiform handle. Flecked (grey and brown) pottery tempered with pebble grit and sand. Dimensions: 50.9 x 19.2 x 5.8 mm. Weight: 7.11 g. Inventory Number: P-51219.
 7. A fragment of the wall of a perforated vessel - sieve. Brown pottery. There are nail impressions on several spots of the outer wall surface. Dimensions: 40.3 x 27.0 x 5.7 mm. Weight: 6.71 g. Inventory Number: P-51373.
 8. A fragment of the wall of a vessel with part of a perforation for mending. Yellow pottery. Dimensions: 44.2 x 37.6 x 6.5 mm. Weight: 16.6 g. Inventory Number: P-51372.
 9. A fragment of the wall of a vessel with a perforation for mending. Dark grey pottery tempered with pebble grit. Brushed outer wall surface. Dimensions: 50.7 x 43.5 x 6.9 mm. Weight: 19.34 g. Inventory Number: P-51220.
 10. A fragment of the wall of a vessel with a plastic strap decorated with finger impressions. Grey pottery tempered with sand. Dimensions: 29.7 x 24.6 x 7.2 mm. Weight: 8.78 g. Inventory Number: P-51364.
 11. A fragment of the vessel wall. Yellow pottery, burnished on the outside. Decorated with 5 shallow, relatively parallel channels. Dimensions: 30.2 x 24.4 x 5.7 mm. Weight: 7.37 g. Inventory Number: P-51221.
 12. A fragment of the neck and belly of a vessel. Grey pottery tempered with sand. Located on the belly is a strap with slanted, incised lines. Dimensions: 43.8 x 25.3 x 5.7 mm. Weight: 9.06 g. Inventory Number: P-51222.
 13. A fragment of one end of a pintadera, based on which it can be presumed that it was rectangular in shape. Flecked (yellow, reddish and dark grey) pottery tempered with pebble grit and sand. It is decorated with deeply incised, parallel, zigzag lines within which it is possible to discern a reddish color. Dimensions: 32.5 x 31.3 x 12.5 mm. Weight: 15.5 g. Inventory Number: P-51374.
- Sonda 2, sloj 3**
14. Izvijeni obod. Smeđa keramika s primjesama pijeska. Glačana vanjska i unutrašnja površina stijenke. Dimenzije: 19,1 x 13,9 x 6,1 mm. Težina: 1,97 g. Inventarni broj: P-51223.
 15. Izvijeni obod. Siva keramika s primjesama pijeska. Dimenzije: 21,3 x 19,9 x 6,0 mm. Težina: 3,42 g. Inventarni broj: P-51231.
- Probe 2, layer 3**
14. An everted rim. Brown pottery tempered with sand. Burnished outer and inner wall surface. Dimensions: 19.1 x 13.9 x 6.1 mm. Weight: 1.97 g. Inventory Number: P-51223.
 15. An everted rim. Grey pottery tempered with sand. Dimensions: 21.3 x 19.9 x 6.0 mm. Weight: 3.42 g. Inventory Number: P-51231.

16. Izvijeni obod. Crna keramika. Glačana vanjska i unutrašnja površina stijenke. Dimenzije: 22,0 x 16,4 x 4,6 mm. Težina: 2,0 g. Inventarni broj: P-51142.

16. An everted rim. Black pottery. Burnished outer and inner wall surface. Dimensions: 22.0 x 16.4 x 4.6 mm. Weight: 2.0 g. Inventory Number: P-51142.

TABLA 12

Sonda 2, sloj 3

1. Ravni obod. Smeđa keramika. Metličasto obrađena vanjska površina stijenke. Dimenzije: 30,5 x 24,4 x 6,3 mm. Težina: 4,81 g. Inventarni broj: P-51150.
2. Uvučeni obod. Izvana smeđa, iznutra tamnosiva keramika s primjesama pijeska. Dimenzije: 36,0 x 31,8 x 6,6 mm. Težina: 9,9 g. Inventarni broj: P-51138.
3. Izvijeni obod. Izvana mrljasta (smeđa i crna), iznutra crna keramika. Glačana vanjska i unutrašnja površina stijenke. Dimenzije: 39,3 x 32,8 x 4,9 mm. Težina: 6,45 g. Inventarni broj: P-51141.
4. Izvijeni obod. Izvana mrljasta (crna i crvenkastosmeđa), iznutra tamnosiva keramika. Glačana vanjska i unutrašnja stijenka posude. Dimenzije: 48,5 x 32,6 x 6,2 mm. Težina: 14,85 g. Inventarni broj: P-51140.
5. Uvučeni obod. Mrljasta (smeđa i tamnosiva) keramika. Dimenzije: 34,8 x 23,2 x 4,0 mm. Težina: 6,11 g. Inventarni broj: P-51227.
6. Izvijeni obod. Izvana mrljasta (smeđa i tamnosiva), iznutra smeđa keramika s primjesama pijeska. Dimenzije: 56,2 x 25,6 x 6,4 mm. Inventarni broj: P-51229.
7. Izvijeni obod. Izvana žutosmeđa, iznutra siva keramika. Metličasto obrađena vanjska i unutrašnja površina stijenke. Dimenzije: 42,8 x 33,2 x 5,3 mm. Težina: 12,75 g. Inventarni broj: P-51139.
8. Ravni obod. Izvana mrljasta (siva i smeđa), iznutra smeđa keramika s primjesama pijeska. Dimenzije: 60,6 x 38,0 x 5,0 mm. Težina: 23,16 g. Inventarni broj: P-51148.
9. Obod zdjele. Tamnosiva keramika s primjesama pijeska. Izvana djelomično metličasto obrađena, a djelomično glačana. Iznutra glačana. Dimenzije: 55,7 x 36,8 x 4,0 mm. Težina: 14,57 g. Inventarni broj: P-51224.
10. Izvijeni obod. Smeđa keramika s primjesama pijeska. Dimenzije: 59,3 x 32,7 x 9,6 mm. Težina: 30,23 g. Inventarni broj: P-51147.
11. Izvijeni obod. Žuta keramika s primjesama pijeska. Očuvana jedna rupica za krpanje. Dimenzije: 40,3 x 35,2 x 5,7 mm. Težina: 13,57 g. Inventarni broj: P-51236.
12. Ravni obod. Tamnosiva keramika. Izvana glačana. Dimenzije: 58,8 x 30,3 x 8,3 mm. Težina: 23,51 g. Inventarni broj: P-51226.

TABLA 12

Probe 2, layer 3

1. A flat rim. Brown pottery. Brushed outer wall surface. Dimensions: 30.5 x 24.4 x 6.3 mm. Weight: 4.81 g. Inventory Number: P-51150.
2. A drawn in rim. Brown pottery on the outside, dark grey on the inside, tempered with sand. Dimensions: 36.0 x 31.8 x 6.6 mm. Weight: 9.9 g. Inventory Number: P-51138.
3. An everted rim. Flecked (brown and black) pottery on the outside, black on the inside. Burnished outer and inner wall surface. Dimensions: 39.3 x 32.8 x 4.9 mm. Weight: 6.45 g. Inventory Number: P-51141.
4. An everted rim. Flecked (black and reddish-brown) pottery on the outside, dark grey on the inside. Burnished outer and inner vessel wall. Dimensions: 48.5 x 32.6 x 6.2 mm. Weight: 14.85 g. Inventory Number: P-51140.
5. A drawn in rim. Flecked (brown and dark grey) pottery. Dimensions: 34.8 x 23.2 x 4.0 mm. Weight: 6.11 g. Inventory Number: P-51227.
6. An everted rim. Flecked (brown and dark grey) pottery on the outside, brown on the inside, tempered with sand. Dimensions: 56.2 x 25.6 x 6.4 mm. Inventory Number: P-51229.
7. An everted rim. Yellow-brown pottery on the outside, grey on the inside. Brushed outer and inner wall surface. Dimensions: 42.8 x 33.2 x 5.3 mm. Weight: 12.75 g. Inventory Number: P-51139.
8. A flat rim. Flecked (grey and brown) pottery on the outside, brown on the inside, tempered with sand. Dimensions: 60.6 x 38.0 x 5.0 mm. Weight: 23.16 g. Inventory Number: P-51148.
9. A bowl rim. Dark grey pottery tempered with sand. On the outside partly brushed and partly burnished. Burnished on the inside. Dimensions: 55.7 x 36.8 x 4.0 mm. Weight: 14.57 g. Inventory Number: P-51224.
10. An everted rim. Brown pottery tempered with sand. Dimensions: 59.3 x 32.7 x 9.6 mm. Weight: 30.23 g. Inventory Number: P-51147.
11. An everted rim. Yellow pottery tempered with sand. A single perforation for mending is preserved. Dimensions: 40.3 x 35.2 x 5.7 mm. Weight: 13.57 g. Inventory Number: P-51236.
12. A flat rim. Dark grey pottery. Burnished on the outside. Dimensions: 58.8 x 30.3 x 8.3 mm. Weight: 23.51 g. Inventory Number: P-51226.

13. Izvijeni obod. Izvana smeđa, iznutra mrljasta (smeđa i tamnosiva) keramika. Izvana glačana, s okomitim, plitkim kanelurama uz vrat prema trбуhu posude. Dimenzije: 50,0 x 48,1 x 7,6 mm. Težina: 20,07 g. Inventarni broj: P-51230.
14. Izvijeni obod. Smeđa keramika. Metličasto obrađena vanjska površina stijenke. Dimenzije: 67,0 x 64,0 x 6,9 mm. Težina: 37,84 g. Inventarni broj: P-51153.
15. Ravni obod. Žučkastosmeđa keramika s primjesama pijeska. Glačana vanjska i unutrašnja površina stijenke. Dimenzije: 62,0 x 56,2 x 6,6 mm. Težina: 31,59 g. Inventarni broj: P-51137.
13. An everted rim. Brown pottery on the outside, flecked (brown and dark grey) on the inside. Burnished on the outside, with vertical, shallow channels running alongside the neck towards the vessel belly. Dimensions: 50.0 x 48.1 x 7.6 mm. Weight: 20.07 g. Inventory Number: P-51230.
14. An everted rim. Brown pottery. Brushed outer wall surface. Dimensions: 67.0 x 64.0 x 6.9 mm. Weight: 37.84 g. Inventory Number: P-51153.
15. A flat rim. Yellowish-brown pottery tempered with sand. Burnished outer and inner wall surface. Dimensions: 62.0 x 56.2 x 6.6 mm. Weight: 31.59 g. Inventory Number: P-51137.

TABLA 13**Sonda 2, sloj 3**

1. Izvijeni obod. Tamnosiva keramika s primjesama pijeska. Metličasto obrađena vanjska i unutrašnja površina stijenke. Dimenzije: 77,3 x 48,3 x 5,4 mm. Težina: 34,47 g. Inventarni broj: P-51232.
2. Ravni obod. Izvana mrljasta (tamnosiva i smeđa), iznutra crna keramika. Ulomak ukrašen širokim, grubim kanelurama izrađenim prstima. Dimenzije: 59,1 x 58,9 x 6,4 mm. Težina: 37,92 g. Inventarni broj: P-51146.
3. Izvijeni obod. Mrljasta (crvenkastosmeđa i crna) keramika s primjesama pijeska. Metličasto obrađena vanjska površina stijenke. Dimenzije: 65,4 x 53,0 x 7,0 mm. Težina: 36,51 g. Inventarni broj: P-51143.
4. Uvučeni obod. Siva keramika s primjesama pijeska. Metličasto obrađena vanjska i unutrašnja površina stijenke. Dimenzije: 58,9 x 50,4 x 7,0 mm. Težina: 33,74 g. Inventarni broj: P-51233.
5. Obod zdjele. Tamnosiva keramika. Glačana vanjska površina stijenke. Dimenzije: 106,1 x 87,2 x 8,5 mm. Težina: 123,15 g. Inventarni broj: P-51228.
6. Izvijeni obod i ulomak stijenke trбуha šalice. Tamnosiva keramika. Glačana vanjska i unutrašnja površina stijenke. Dimenzije oboda: 37,3 x 23,1 x 4,4 mm. Težina: 6,32. Dimenzije stijenke trбуha: 42,2 x 37,7 x 5,5 mm. Težina: 11,19 g. Inventarni broj: P-51225.
7. Obod široke zdjele. Na usni prstima izvučeno plastično ispupčenje. Žučkastosmeđa keramika s primjesama sitnih kamenčića i pijeska. Glačana vanjska i unutrašnja površina stijenke. Dimenzije: 92,2 x 48,5 x 5,7 mm. Težina: 43,84 g. Inventarni broj: P-51149.
8. Obod koji je izrazito ukošen prema van. Crna keramika, glačana izvana i iznutra. Na unutrašnjoj stijenci nalazi se ulomak šrafiranog trokutića.
1. An everted rim. Dark grey pottery tempered with sand. Brushed outer and inner wall surface. Dimensions: 77.3 x 48.3 x 5.4 mm. Weight: 34.47 g. Inventory Number: P-51232.
2. A flat rim. Flecked (dark grey and brown) pottery on the outside, black on the inside. The fragment is decorated with coarse, broad channels executed with fingers. Dimensions: 59.1 x 58.9 x 6.4 mm. Weight: 37.92 g. Inventory Number: P-51146.
3. An everted rim. Flecked (reddish-brown and black) pottery tempered with sand. Brushed outer wall surface. Dimensions: 65.4 x 53.0 x 7.0 mm. Weight: 36.51 g. Inventory Number: P-51143.
4. A drawn in rim. Grey pottery tempered with sand. Brushed outer and inner wall surface. Dimensions: 58.9 x 50.4 x 7.0 mm. Weight: 33.74 g. Inventory Number: P-51233.
5. A bowl rim. Dark grey pottery. Burnished outer wall surface. Dimensions: 106.1 x 87.2 x 8.5 mm. Weight: 123.15 g. Inventory Number: P-51228.
6. An everted rim and a fragment of the belly wall of a cup. Dark grey pottery. Burnished outer and inner wall surface. Dimensions of the rim: 37.3 x 23.1 x 4.4 mm. Weight: 6.32. Dimensions of the belly wall: 42.2 x 37.7 x 5.5 mm. Weight: 11.19 g. Inventory Number: P-51225.
7. A broad bowl rim. Located on the lip is a plastic protuberance drawn out with fingers. Yellowish-brown pottery tempered with pebble grit and sand. Burnished outer and inner wall surface. Dimensions: 92.2 x 48.5 x 5.7 mm. Weight: 43.84 g. Inventory Number: P-51149.
8. A rim particularly slanted towards the outside. Black pottery, burnished both on the outside and inside. Located on the inner wall is a fragment of a small hatched triangle. Dimensions: 38.8 x 20.9 x 6.0 mm. Weight: 4.36 g. Inventory Number: P-51190.

TABLA 13**Probe 2, layer 3**

Dimenzije: 38,8 x 20,9 x 6,0 mm. Težina: 4,36 g.
Inventarni broj: P-51190.

9. Izvijeni obod. Usna ukrašena utiscima nekim predmetom. Smeđa keramika s primjesama pijeska. Metličasto obrađena vanjska i unutrašnja površina stijenke. Dimenzije: 25,0 x 23,6 x 6,4 mm. Težina: 5,25 g. Inventarni broj: P-51151.

TABLA 14

Sonda 2, sloj 3

1. Izvijeni obod. Na usni oboda vidljiv utisak prstom. Siva keramika s primjesama sitnih kamenčića i pijeska. Metličasto obrađena vanjska površina stijenke. Dimenzije: 35,0 x 12,2 x 5,0 mm. Težina: 5,0 g. Inventarni broj: P-51234.
2. Uvučeni obod. Usna ukrašena utiscima oštrim predmetom. Crna keramika s primjesama sitnih kamenčića i pijeska. Dimenzije: 22,8 x 19,2 x 4,0 mm. Težina: 3,4 g. Inventarni broj: P-51144.
3. Izvijeni obod. Usna ukrašena utiscima noktom. Smeđa keramika s primjesama pijeska. Dimenzije: 31,4 x 31,4 x 7,6 mm. Težina: 13,9 g. Inventarni broj: P-51145.
4. Ravni obod. Usna ukrašena utiscima noktom. Izvana crvenkastosmeđa, iznutra smeđa keramika s primjesama pijeska. Dimenzije: 50,0 x 36,4 x 6,3 mm. Težina: 16,33 g. Inventarni broj: P-51154.
5. Izvijeni obod. Usna ukrašena utiscima nekim predmetom. Smeđa keramika. Ispod oboda zadebljanje s utiscima prstom. Metličasto obrađena vanjska površina stijenke. Dimenzije: 39,4 x 33,1 x 9,4 mm. Inventarni broj: P-51152.
6. Uvučeni obod. Usna ukrašena utiscima noktom. Izvana žučkastosmeđa, iznutra siva keramika s primjesama pijeska. Dimenzije: 52,9 x 49,3 x 8,3 mm. Težina: 22,32 g. Inventarni broj: P-51235.
7. Ravno dno. Siva keramika s primjesama sitnih kamenčića i pijeska. Stijenka je blago konkavna i metličasto obrađena na vanjskoj površini. Dimenzije: 38,2 x 22,0 x 7,3 mm. Težina: 26,77 g. Inventarni broj: P-51158.
8. Ravno dno. Žučkastosmeđa keramika s primjesama pijeska. Stijenka je ravna i metličasto ukrašena na vanjskoj površini. Dimenzije: 31,6 x 31,0 x 14,1 mm. Težina: 21,81 g. Inventarni broj: P-51238.
9. Ravno dno. Smeđa keramika s primjesama sitnih kamenčića i pijeska. Stijenka je ravna i glačana na vanjskoj površini. Dimenzije: 45,9 x 36,6 x 8,5 mm. Težina: 18,8 g. Inventarni broj: P-51156.
10. Ravno dno. Izvana siva, iznutra mrljasta (žuta i tamnosiva) keramika s primjesama pijeska. Stijenka

9. An everted rim. The lip is decorated with impressions with an unidentified object. Brown pottery tempered with sand. Brushed outer and inner wall surface. Dimensions: 25.0 x 23.6 x 6.4 mm. Weight: 5.25 g. Inventory Number: P-51151.

TABLA 14

Probe 2, layer 3

1. An everted rim. On the lip of the rim is a visible finger impression. Grey pottery tempered with pebble grit and sand. Brushed outer wall surface. Dimensions: 35.0 x 12.2 x 5.0 mm. Weight: 5.0 g. Inventory Number: P-51234.
2. A drawn in rim. The lip is decorated with impressions made with a sharp object. Black pottery tempered with pebble grit and sand. Dimensions: 22.8 x 19.2 x 4.0 mm. Weight: 3.4 g. Inventory Number: P-51144.
3. An everted rim. The lip is decorated with nail impressions. Brown pottery tempered with sand. Dimensions: 31.4 x 31.4 x 7.6 mm. Weight: 13.9 g. Inventory Number: P-51145.
4. A flat rim. The lip is decorated with nail impressions. Reddish-brown pottery on the outside, brown on the inside, tempered with sand. Dimensions: 50.0 x 36.4 x 6.3 mm. Weight: 16.33 g. Inventory Number: P-51154.
5. An everted rim. The lip is decorated with impressions made with an unidentified object. Brown pottery. Located underneath the rim is a thickening with finger impressions. Brushed outer wall surface. Dimensions: 39.4 x 33.1 x 9.4 mm. Inventory Number: P-51152.
6. A drawn in rim. The lip is decorated with nail impressions. Yellowish-brown pottery on the outside, grey on the inside, tempered with sand. Dimensions: 52.9 x 49.3 x 8.3 mm. Weight: 22.32 g. Inventory Number: P-51235.
7. A flat base. Grey pottery tempered with pebble grit and sand. The wall is slightly concave and brushed on the outer surface. Dimensions: 38.2 x 22.0 x 7.3 mm. Weight: 26.77 g. Inventory Number: P-51158.
8. A flat base. Yellowish-brown pottery tempered with sand. The wall is flat and brushed on the outer surface. Dimensions: 31.6 x 31.0 x 14.1 mm. Weight: 21.81 g. Inventory Number: P-51238.
9. A flat base. Brown pottery tempered with pebble grit and sand. The wall is flat and burnished on the outer surface. Dimensions: 45.9 x 36.6 x 8.5 mm. Weight: 18.8 g. Inventory Number: P-51156.
10. A flat base. Grey pottery on the outside, flecked (yellow and dark grey) on the inside, tempered with sand. The wall is flat. Dimensions: 49.3 x 32.4

je ravna. Dimenzije: 49,3 x 32,4 x 11,0 mm. Težina: 22,69 g. Inventarni broj: P-51161.

11. Ravno dno na peticu. Siva keramika s primjesama sitnih kamenčića i pijeska. Stijenka je ravna i metličasto obrađena na vanjskoj površini. Dimenzije: 49,3 x 38,0 x 6,5 mm. Težina: 26,77 g. Inventarni broj: P-51157.
12. Ravno dno. Izvana smeđa, iznutra mrljasta (siva i crna) keramika s primjesama sitnih kamenčića i pijeska. Stijenka je ravna i metličasto obrađena na vanjskoj površini. Dimenzije: 63,0 x 42,4 x 12,4 mm. Težina: 45,63 g. Inventarni broj: P-51160.
13. Ravno dno. Izvana smeđa, iznutra crna keramika s primjesama sitnih kamenčića i pijeska. Stijenka je ravna i metličasto obrađena na vanjskoj površini. Dimenzije: 80,5 x 35,9 x 10,1 mm. Težina: 40,53 g. Inventarni broj: P-51237.
14. Ravno dno. Izvana mrljasta (tamnosiva i smeđa), iznutra smeđa keramika s primjesama sitnih kamenčića i pijeska. Stijenka nije očuvana. Dimenzije: 100,8 x 64,7 x 10,0 mm. Težina: 89,22 g. Inventarni broj: P-51163.

TABLA 15

Sonda 2, sloj 3

1. Ravno dno. Izvana siva, iznutra smeđa keramika s primjesama pijeska. Stijenka nije očuvana. Dimenzije: 90,5 x 79,9 x 7,3 mm. Težina: 62,73 g. Inventarni broj: P-51155.
2. Ravno dno na peticu. Žuta keramika s primjesama pijeska. Stijenka je ravna. Dimenzije: 57,0 x 52,7 x 9,0 mm. Težina: 35,66 g. Inventarni broj: P-51159.
3. Ravno dno. Izvana žuta, iznutra crna keramika. Stijenka je ravna i metličasto obrađena na vanjskoj površini. Dimenzije: 105,0 x 102,0 x 7,4 mm. Težina: 143,29 g. Inventarni broj: P-51162.
4. Ravno dno. S vanjske strane na dnu je utisnut konop ili predmet koji ostavlja sličan trag. Mrljasta (tamnosiva i smeđa) keramika s primjesama pijeska. Stijenka je ravna i metličasto obrađena na vanjskoj površini. Dimenzije: 110,7 x 66,2 x 7,0 mm. Težina: 82,92 g. Inventarni broj: P-51240.
5. Ulomak stijenke s trbuha posude, s očuvanim ulomkom ručke. Mrljasta (smeđa i tamnosiva) keramika s primjesama sitnih kamenčića i pijeska. Dimenzije: 57,9 x 28,6 x 6,7 mm. Težina: 31,55 g. Inventarni broj: P-51164.
6. Ulomak stijenke s trbuha posude, s očuvanim ulomkom ručke. Izvana mrljasta (tamnosiva i smeđa), iznutra tamnosiva keramika s primjesama pijeska. Metličasto obrađena vanjska površina stijenke. Dimenzije: 96,9 x 58,7 x 7,5 mm. Težina: 122,15 g. Inventarni broj: P-51240.

x 11.0 mm. Weight: 22.69 g. Inventory Number: P-51161.

11. A flat heel-base. Grey pottery tempered with pebble grit and sand. The wall is flat and brushed on the outer surface. Dimensions: 49.3 x 38.0 x 6.5 mm. Weight: 26.77 g. Inventory Number: P-51157.
12. A flat base. Brown pottery on the outside, flecked (grey and black) on the inside, tempered with pebble grit and sand. The wall is flat and brushed on the outer surface. Dimensions: 63.0 x 42.4 x 12.4 mm. Weight: 45.63 g. Inventory Number: P-51160.
13. A flat base. Brown pottery on the outside, black on the inside, tempered with pebble grit and sand. The wall is flat and brushed on the outer surface. Dimensions: 80.5 x 35.9 x 10.1 mm. Weight: 40.53 g. Inventory Number: P-51237.
14. A flat base. Flecked (dark grey and brown) pottery on the outside, brown on the inside, tempered with pebble grit and sand. The wall is not preserved. Dimensions: 100.8 x 64.7 x 10.0 mm. Weight: 89.22 g. Inventory Number: P-51163.

TABLA 15

Probe 2, layer 3

1. A flat base. Grey pottery on the outside, brown on the inside, tempered with sand. The wall is not preserved. Dimensions: 90.5 x 79.9 x 7.3 mm. Weight: 62.73 g. Inventory Number: P-51155.
2. A flat heel-base. Yellow pottery tempered with sand. The wall is flat. Dimensions: 57.0 x 52.7 x 9.0 mm. Weight: 35.66 g. Inventory Number: P-51159.
3. A flat base. Yellow pottery on the outside, black on the inside. The wall is flat and brushed on the outer surface. Dimensions: 105.0 x 102.0 x 7.4 mm. Weight: 143.29 g. Inventory Number: P-51162.
4. A flat base. On the outer side of the base is an impression made by a rope or an object leaving a similar trace. Flecked (dark grey and brown) pottery tempered with sand. The wall is flat and brushed on the outer surface. Dimensions: 110.7 x 66.2 x 7.0 mm. Weight: 82.92 g. Inventory Number: P-51240.
5. A fragment of the belly wall of a vessel with a preserved fragment of a handle. Flecked (brown and dark grey) pottery tempered with pebble grit and sand. Dimensions: 57.9 x 28.6 x 6.7 mm. Weight: 31.55 g. Inventory Number: P-51164.
6. A fragment of the belly wall of a vessel with a preserved fragment of a handle. Flecked (dark grey and brown) pottery on the outside, dark grey on the inside, tempered with sand. Brushed outer wall surface. Dimensions: 96.9 x 58.7 x 7.5 mm. Weight: 122.15 g. Inventory Number: P-51240.

TABLA 16**Sonda 2, sloj 3**

1. Ulomak stijenke posude s dijelom rupice za krpanje. Smeđa keramika. Dimenzije: 34,0 x 22,6 x 7,0 mm. Težina: 4,8 g. Inventarni broj: P-51241.
2. Ulomak stijenke posude s rupicom za krpanje. Crna keramika. Metličasto obrađena vanjska površina stijenke. Dimenzije: 49,5 x 31,4 x 6,8 mm. Težina: 14,13 g. Inventarni broj: P-51167.
3. Ulomak stijenke posude. Siva keramika s primjesama sitnih kamenčića i pijeska. Vidljive dvije utisnute linije koje bi mogle tvoriti cik-cak. Dimenzije: 39,8 x 22,4 x 7,6 mm. Težina: 8,04 g.
4. Ulomak stijenke posude s bikonitetom. Izvana tamnosiva, iznutra smeđa keramika. Na najširem dijelu trbuha nalaze se plitke, ukošene kanelure. Dimenzije: 28,7 x 23,1 x 5,9 mm. Težina: 4,29 g. Inventarni broj: P-51242.
5. Ulomak stijenke posude. Izvana smeđa, iznutra crna keramika s primjesama sitnih kamenčića i pijeska. Glačana vanjska površina stijenke. Ukrašena urezanim, nepravilnim linijama. Dimenzije: 65,5 x 45,9 x 4,5 mm. Težina: 17,61 g. Inventarni broj: P-51166.
6. Ulomak vrata i trbuha posude. Crna keramika. Na najširem dijelu trbuha ukrašena širokim utiscima prstom. Glačane vanjska i unutrašnja površina stijenke. Dimenzije: 74,0 x 45,9 x 5,6 mm. Težina: 35,39 g. Inventarni broj: P-51165.
7. Ulomak trbuha posude s bikonitetom. Žućkastosmeđa keramika s primjesama sitnih kamenčića i pijeska. Dimenzije: 141,7 x 65,2 x 7,0 mm. Težina: 110,69 g. Inventarni broj: P-51168.
8. Ulomak stijenke velike posude. Izvana siva, iznutra smeđa keramika s primjesama pijeska. Metličasto obrađena vanjska i unutrašnja površina stijenke. Izvana je prošarana okomito i kružno, a iznutra vodoravno i gotovo užlijebljeno. Dimenzije: 172,4 x 124,9 x 8,2 mm. Težina: 198,91 g. Inventarni broj: P-51169.

TABLA 17**Sonda 2, sloj 4**

1. Ravni obod. Smeđa keramika s primjesama pijeska. Dimenzije: 22,9 x 9,6 x 6,4 mm. Težina: 1,87 g. Inventarni broj: P-51245.
2. Izvijeni obod. Siva keramika. Glačana unutrašnja površina stijenke. Dimenzije: 28,8 x 16,0 x 5,5 mm. Težina: 2,02 g. Inventarni broj: P-51259.
3. Ravni obod. Izvana smeđa, iznutra tamnosiva

TABLE 16**Probe 2, layer 3**

1. A fragment of the vessel wall with part of a perforation used for mending. Brown pottery. Dimensions: 34.0 x 22.6 x 7.0 mm. Weight: 4.8 g. Inventory Number: P-51241.
2. A fragment of the vessel wall with a perforation used for mending. Black pottery. Brushed outer wall surface. Dimensions: 49.5 x 31.4 x 6.8 mm. Weight: 14.13 g. Inventory Number: P-51167.
3. A fragment of the vessel wall. Grey pottery tempered with pebble grit and sand. Two impressed lines are visible, which might run in a zigzag manner. Dimensions: 39.8 x 22.4 x 7.6 mm. Weight: 8.04 g.
4. A fragment of the wall of a vessel with carination. Dark grey pottery on the outside, brown on the inside. Located on the broadest section of the belly are shallow, slanted channels. Dimensions: 28.7 x 23.1 x 5.9 mm. Weight: 4.29 g. Inventory Number: P-51242.
5. A fragment of the vessel wall. Brown pottery on the outside, black on the inside, tempered with pebble grit and sand. Burnished outer wall surface. Decorated with incised, irregular lines. Dimensions: 65.5 x 45.9 x 4.5 mm. Weight: 17.61 g. Inventory Number: P-51166.
6. A fragment of the neck and belly of a vessel. Black pottery. Decorated with wide finger impressions on the broadest section of the belly. Burnished outer and inner wall surface. Dimensions: 74.0 x 45.9 x 5.6 mm. Weight: 35.39 g. Inventory Number: P-51165.
7. A fragment of the belly of a vessel with carination. Yellowish-brown pottery tempered with pebble grit and sand. Dimensions: 141.7 x 65.2 x 7.0 mm. Weight: 110.69 g. Inventory Number: P-51168.
8. A fragment of the wall of a large vessel. Grey pottery on the outside, brown on the inside, tempered with sand. Brushed outer and inner wall surface. On the outside treated with vertical and circular strokes, on the inside with horizontal ones that are almost furrowed. Dimensions: 172.4 x 124.9 x 8.2 mm. Weight: 198.91 g. Inventory Number: P-51169.

TABLE 17**Probe 2, layer 4**

1. A flat rim. Brown pottery tempered with sand. Dimensions: 22.9 x 9.6 x 6.4 mm. Weight: 1.87 g. Inventory Number: P-51245.
2. An everted rim. Grey pottery. Burnished inner wall surface. Dimensions: 28.8 x 16.0 x 5.5 mm. Weight: 2.02 g. Inventory Number: P-51259.
3. A flat rim. Brown pottery on the outside, dark grey

- keramika. Dimenzije: 28,7 x 19,1 x 6,7 mm. Težina: 2,85 g. Inventarni broj: P-51260.
4. Izrazito izvijeni obod. Crna keramika. Glačana vanjska i unutrašnja površina stijenke. Dimenzije: 26,1 x 17,1 x 3,9 mm. Težina: 1,71 g. Inventarni broj: P-51125.
 5. Ravni obod. Izvana mrljasta (smeđa i crna), iznutra crna keramika. Glačana vanjska i unutrašnja površina stijenke. Dimenzije: 33,0 x 29,4 x 4,5 mm. Težina: 4,49 g. Inventarni broj: P-51109.
 6. Ravni obod. Izvana smeđa, iznutra siva keramika. Metličasto obrađena vanjska površina stijenke. Dimenzije: 29,3 x 21,2 x 6,3 mm. Težina: 4,67 g. Inventarni broj: P-51111.
 7. Izvijeni obod. Izvana smeđa, iznutra siva keramika s primjesama sitnog pijeska. Dimenzije: 29,5 x 21,2 x 5,4 mm. Težina: 5,38 g. Inventarni broj: P-51250.
 8. Ravni obod. Tamnosiva keramika. Dimenzije: 35,0 x 24,1 x 6,0 mm. Težina: 9,1 g. Inventarni broj: P-51128.
 9. Izvijeni obod. Crna keramika s primjesama pijeska. Glačana vanjska i unutrašnja površina stijenke. Niz vrat se naziru plitke, okomite kanelure. Dimenzije: 25,3 x 21,2 x 3,6 mm. Težina: 3,19 g. Inventarni broj: P-51254.
 10. Izvijeni obod. Izvana crna, iznutra sivosmeđa keramika. Glačana vanjska i unutrašnja površina stijenke. Dimenzije: 36,2 x 27,7 x 5,7 mm. Težina: 8,05 g. Inventarni broj: P-51251.
 11. Izvijeni obod. Smeđa keramika. Dimenzije: 35,9 x 25,1 x 4,7 mm. Težina: 7,52 g. Inventarni broj: P-51247.
 12. Ravni obod sa zadebljanjem s vanjske strane stijenke. Sivosmeđa keramika s primjesama sitnih kamenčića i pijeska. Dimenzije: 37,7 x 37,3 x 5,1 mm. Težina: 9,67 g. Inventarni broj: P-51262.
 13. Ravni obod. Tamnosiva keramika. Glačana vanjska i unutrašnja površina stijenke. Dimenzije: 42,4 x 41,0 x 4,0 mm. Težina: 10,98 g. Inventarni broj: P-51261.
 14. Izvijeni obod. Crna keramika. Glačana vanjska i unutrašnja površina stijenke. Dimenzije: 37,3 x 35,1 x 5,6 mm. Težina: 10,14 g. Inventarni broj: P-51249.
 15. Uvučeni obod. Smeđa keramika s primjesama pijeska. Metličasto obrađena vanjska površina stijenke. Dimenzije: 39,8 x 27,0 x 6,4 mm. Težina: 9,48 g. Inventarni broj: P-51268.
 16. Uvučeni obod. Siva keramika s primjesama pijeska. Metličasto obrađena vanjska površina stijenke. Ispod oboda vidjive su dvije vodoravne urezane linije. Na donjem desnom dijelu ulomka površina na mjestu loma je izglučana. Dimenzije: 41,3 x 30,9 x 5,7 mm. Težina: 9,97 g. Inventarni broj: P-51273.
- on the inside. Dimensions: 28.7 x 19.1 x 6.7 mm. Weight: 2.85 g. Inventory Number: P-51260.
4. A particularly everted rim. Black pottery. Burnished outer and inner wall surface. Dimensions: 26.1 x 17.1 x 3.9 mm. Weight: 1.71 g. Inventory Number: P-51125.
 5. A flat rim. Flecked (brown and black) pottery on the outside, black on the inside. Burnished outer and inner wall surface. Dimensions: 33.0 x 29.4 x 4.5 mm. Weight: 4.49 g. Inventory Number: P-51109.
 6. A flat rim. Brown pottery on the outside, grey on the inside. Brushed outer wall surface. Dimensions: 29.3 x 21.2 x 6.3 mm. Weight: 4.67 g. Inventory Number: P-51111.
 7. An everted rim. Brown pottery on the outside, grey on the inside, tempered with sand. Dimensions: 29.5 x 21.2 x 5.4 mm. Weight: 5.38 g. Inventory Number: P-51250.
 8. A flat rim. Dark grey pottery. Dimensions: 35.0 x 24.1 x 6.0 mm. Weight: 9.1 g. Inventory Number: P-51128.
 9. An everted rim. Black pottery tempered with sand. Burnished outer and inner wall surface. Shallow, vertical channels can be discerned down the neck. Dimensions: 25.3 x 21.2 x 3.6 mm. Weight: 3.19 g. Inventory Number: P-51254.
 10. An everted rim. Black pottery on the outside, grey-brown on the inside. Burnished outer and inner wall surface. Dimensions: 36.2 x 27.7 x 5.7 mm. Weight: 8.05 g. Inventory Number: P-51251.
 11. An everted rim. Brown pottery. Dimensions: 35.9 x 25.1 x 4.7 mm. Weight: 7.52 g. Inventory Number: P-51247.
 12. A flat rim with a thickening on the outer side of the wall. Grey-brown pottery tempered with pebble grit and sand. Dimensions: 37.7 x 37.3 x 5.1 mm. Weight: 9.67 g. Inventory Number: P-51262.
 13. A flat rim. Dark grey pottery. Burnished outer and inner wall surface. Dimensions: 42.4 x 41.0 x 4.0 mm. Weight: 10.98 g. Inventory Number: P-51261.
 14. An everted rim. Black pottery. Burnished outer and inner wall surface. Dimensions: 37.3 x 35.1 x 5.6 mm. Weight: 10.14 g. Inventory Number: P-51249.
 15. A drawn in rim. Brown pottery tempered with sand. Brushed outer wall surface. Dimensions: 39.8 x 27.0 x 6.4 mm. Weight: 9.48 g. Inventory Number: P-51268.
 16. A drawn in rim. Grey pottery tempered with sand. Brushed outer wall surface. Visible underneath the rim are two incised horizontal lines. On the lower right section of the fragment, the surface at the breaking spot is burnished. Dimensions: 41.3 x 30.9 x 5.7 mm. Weight: 9.97 g. Inventory Number: P-51273.

17. Uvučeni obod. Tamnosiva keramika s primjesama pijeska. Dimenzije: 50,1 x 32,5 x 7,3 mm. Težina: 13,47 g. Inventarni broj: P-51244.
18. Izvijeni obod. Izvana smeđa, iznutra mrljasta (smeđa i crna) keramika. Glačana vanjska i unutrašnja površina stijenke. Dimenzije: 43,0 x 30,7 x 6,5 mm. Težina: 13,67 g. Inventarni broj: P-51258.
19. Ravni obod. Mrljasta (smeđa i tamnosiva) keramika. Dimenzije: 49,3 x 43,2 x 6,5 mm. Težina: 11,98 g. Inventarni broj: P-51248.
20. Ravni obod. Crna keramika. Dimenzije: 56,3 x 28,1 x 6,0 mm. Težina: 11,74 g. Inventarni broj: P-51253.
21. Izvijeni obod. Tamnosiva keramika. Glačana vanjska i unutrašnja površina stijenke. Dimenzije: 44,4 x 42,7 x 6,4 mm. Težina: 17,44 g. Inventarni broj: P-51123.

TABLA 18**Sonda 2, sloj 4**

1. Izvijeni obod. Mrljasta (smeđa i tamnosiva) keramika s primjesama pijeska. Dimenzije: 44,8 x 39,3 x 8,5 mm. Težina: 20,35 g. Inventarni broj: P-51124.
2. Izvijeni obod. Tamnosmeđa keramika. Glačana vanjska i unutrašnja površina stijenke. Okomite, plitke kanelure niz vrat. Dimenzije: 41,5 x 37,3 x 4,9 mm. Težina: 11,49 g. Inventarni broj: P-51127.
3. Izvijeni obod. Tamnosiva keramika s primjesama pijeska. Dimenzije: 47,0 x 39,0 x 6,0 mm. Težina: 14,99 g. Inventarni broj: P-51101.
4. Izvijeni obod. Usna je oštećena. Siva keramika s primjesama pijeska. Dimenzije: 35,0 x 33,0 x 6,5 mm. Težina: 8,24 g. Inventarni broj: P-51102.
5. Uvučeni obod. Izvana mrljasta (smeđa i tamnosiva), iznutra crna keramika s primjesama pijeska. Metličasto obrađena vanjska i unutrašnja površina stijenke. Dimenzije: 53,0 x 46,3 x 6,2 mm. Težina: 22,28 g. Inventarni broj: P-51280.
6. Uvučeni obod. Izvana smeđa, iznutra siva keramika. Dimenzije: 43,4 x 40,5 x 5,5 mm. Težina: 13,95 g. Inventarni broj: P-51252.
7. Izvijeni obod. Crna keramika s primjesama pijeska. Glačana vanjska i unutrašnja površina stijenke. Dimenzije: 61,8 x 32,0 x 5,6 mm. Težina: 12,17 g. Inventarni broj: P-51246.
8. Uvučeni obod. Mrljasta (smeđa i siva) keramika s primjesama pijeska. Metličasto obrađena vanjska i unutrašnja površina stijenke. Dimenzije: 60,0 x 47,0 x 7,3 mm. Težina: 28,01 g. Inventarni broj: P-51269.
9. Uvučeni obod. Žuta keramika s primjesama pijeska. Dimenzije: 63,6 x 59,1 x 7,6 mm. Težina: 33,6 g. Inventarni broj: P-51256.

TABLA 18**Probe 2, layer 4**

1. An everted rim. Flecked (brown and dark grey) pottery tempered with sand. Dimensions: 44.8 x 39.3 x 8.5 mm. Weight: 20.35 g. Inventory Number: P-51124.
2. An everted rim. Dark brown pottery. Burnished outer and inner wall surface. Vertical, shallow channels down the neck. Dimensions: 41.5 x 37.3 x 4.9 mm. Weight: 11.49 g. Inventory Number: P-51127.
3. An everted rim. Dark grey pottery tempered with sand. Dimensions: 47.0 x 39.0 x 6.0 mm. Weight: 14.99 g. Inventory Number: P-51101.
4. An everted rim. The lip is damaged. Grey pottery tempered with sand. Dimensions: 35.0 x 33.0 x 6.5 mm. Weight: 8.24 g. Inventory Number: P-51102.
5. A drawn in rim. Flecked (brown and dark grey) pottery on the outside, black on the inside, tempered with sand. Brushed outer and inner wall surface. Dimensions: 53.0 x 46.3 x 6.2 mm. Weight: 22.28 g. Inventory Number: P-51280.
6. A drawn in rim. Brown pottery on the outside, grey on the inside. Dimensions: 43.4 x 40.5 x 5.5 mm. Weight: 13.95 g. Inventory Number: P-51252.
7. An everted rim. Black pottery tempered with sand. Burnished outer and inner wall surface. Dimensions: 61.8 x 32.0 x 5.6 mm. Weight: 12.17 g. Inventory Number: P-51246.
8. A drawn in rim. Flecked (brown and grey) pottery tempered with sand. Brushed outer and inner wall surface. Dimensions: 60.0 x 47.0 x 7.3 mm. Weight: 28.01 g. Inventory Number: P-51269.
9. A drawn in rim. Yellow pottery tempered with sand. Dimensions: 63.6 x 59.1 x 7.6 mm. Weight: 33.6 g. Inventory Number: P-51256.

10. Uvučeni obod. Mrljasta (smeđa i siva) keramika s primjesama pijeska. Metličasto obrađena vanjska površina stijenke. Dimenzije: 59,8 x 58,1 x 6,6 mm. Težina: 40,35 g. Inventarni broj: P-51265.
11. Izvijeni obod. Izvana mrljasta (tamnosiva i smeđa), iznutra siva keramika s primjesama sitnih kamenčića i pijeska. Dimenzije: 71,0 x 58,0 x 7,0 mm. Težina: 40,56 g. Inventarni broj: P-51100.
12. Ravni obod. Siva keramika s primjesama pijeska. Dimenzije: 62,5 x 49,7 x 9,0 mm. Težina: 36,45 g. Inventarni broj: P-51127.

TABLA 19**Sonda 2, sloj 4**

1. Ravni obod. Smeđa keramika. Metličasto obrađena vanjska i unutrašnja površina stijenke. Dimenzije: 91,5 x 45,6 x 8,0 mm. Težina: 59,35 g. Inventarni broj: P-51267.
2. Izvijeni obod. Usna ukrašena utiscima noktom. Smeđa keramika s primjesama pijeska. Dimenzije: 26,1 x 14,5 x 7,2 mm. Težina: 2,49 g. Inventarni broj: P-51277.
3. Izvijeni obod. Usna ukrašena utiscima noktom. Izvana smeđa, iznutra siva keramika s primjesama pijeska. Metličasto obrađena vanjska površina stijenke. Dimenzije: 39,2 x 19,9 x 5,7 mm. Težina: 6,61 g. Inventarni broj: P-51278.
4. Izvijeni obod. Usna ukrašena utiscima prstom. Sivosmeđa keramika s primjesama pijeska. Metličasto obrađena vanjska površina stijenke. Dimenzije: 29,0 x 29,0 x 6,0 mm. Težina: 6,7 g. Inventarni broj: P-51274.
5. Uvučeni obod. Smeđa keramika. Ispod oboda nalazi se loše očuvana plastična traka. Dimenzije: 41,8 x 34,8 x 7,3 mm. Težina: 16,89 g. Inventarni broj: P-51286.
6. Izvijeni obod. Izvana smeđa, iznutra tamnosiva keramika s primjesama pijeska. Ispod oboda nalazi se loše očuvana plastična traka. Dimenzije: 46,4 x 36,7 x 12,5 mm. Težina: 24,76 g. Inventarni broj: P-51133.
7. Uvučeni obod. Usna ukrašena utiscima noktom. Smeđa keramika s primjesama pijeska. Ispod oboda nalazi se plastična traka ukrašena štipanjem. Dimenzije: 55,3 x 38,2 x 9,4 mm. Težina: 33,39 g. Inventarni broj: P-51283.
8. Izvijeni obod. Usna ukrašena utiscima prsta. Siva keramika s primjesama pijeska. Dimenzije: 46,5 x 39,6 x 7,1 mm. Težina: 19,56 g. Inventarni broj: P-51106.
9. Izvijeni obod. Usna ukrašena utiscima noktom. Tamnosiva keramika s primjesama sitnih kamenčića

10. A drawn in rim. Flecked (brown and grey) pottery tempered with sand. Brushed outer wall surface. Dimensions: 59.8 x 58.1 x 6.6 mm. Weight: 40.35 g. Inventory Number: P-51265.
11. An everted rim. Flecked (dark grey and brown) pottery on the outside, grey on the inside, tempered with pebble grit and sand. Dimensions: 71.0 x 58.0 x 7.0 mm. Weight: 40.56 g. Inventory Number: P-51100.
12. A flat rim. Grey pottery tempered with sand. Dimensions: 62.5 x 49.7 x 9.0 mm. Weight: 36.45 g. Inventory Number: P-51127.

TABLA 19**Probe 2, layer 4**

1. A flat rim. Brown pottery. Brushed outer and inner wall surface. Dimensions: 91.5 x 45.6 x 8.0 mm. Weight: 59.35 g. Inventory Number: P-51267.
2. An everted rim. The lip is decorated with nail impressions. Brown pottery tempered with sand. Dimensions: 26.1 x 14.5 x 7.2 mm. Weight: 2.49 g. Inventory Number: P-51277.
3. An everted rim. The lip is decorated with nail impressions. Brown pottery on the outside, grey on the inside, tempered with sand. Brushed outer wall surface. Dimensions: 39.2 x 19.9 x 5.7 mm. Weight: 6.61 g. Inventory Number: P-51278.
4. An everted rim. The lip is decorated with finger impressions. Grey-brown pottery tempered with sand. Brushed outer wall surface. Dimensions: 29.0 x 29.0 x 6.0 mm. Weight: 6.7 g. Inventory Number: P-51274.
5. A drawn in rim. Brown pottery. Located underneath the rim is a poorly preserved plastic strap. Dimensions: 41.8 x 34.8 x 7.3 mm. Weight: 16.89 g. Inventory Number: P-51286.
6. An everted rim. Brown pottery on the outside, dark grey on the inside, tempered with sand. Located underneath the rim is a poorly preserved plastic strap. Dimensions: 46.4 x 36.7 x 12.5 mm. Weight: 24.76 g. Inventory Number: P-51133.
7. A drawn in rim. The lip is decorated with nail impressions. Brown pottery tempered with sand. Located underneath the rim is a plastic strap decorated with pinching. Dimensions: 55.3 x 38.2 x 9.4 mm. Weight: 33.39 g. Inventory Number: P-51283.
8. An everted rim. The lip is decorated with finger impressions. Grey pottery tempered with sand. Dimensions: 46.5 x 39.6 x 7.1 mm. Weight: 19.56 g. Inventory Number: P-51106.
9. An everted rim. The lip is decorated with nail impressions. Dark grey pottery tempered with

- i pijeska. Metličasto obrađena vanjska površina stijenke. Dimenzije: 50,5 x 29,0 x 6,4 mm. Težina: 15,09 g. Inventarni broj: P-51270.
10. Izvijeni obod. Usna ukrašena utiscima noktom. Mrljasta (smeđa i crna) keramika. Metličasto obrađena vanjska površina stijenke. Dimenzije: 51,3 x 41,1 x 7,6 mm. Težina: 26,43 g. Inventarni broj: P-51271.
11. Uvučeni obod. Usna ukrašena utiscima prstom. Siva keramika. Ispod oboda nalazi se plastična traka ukrašena utiscima prstom. Dimenzije: 61,7 x 51,5 x 8,8 mm. Težina: 45,82 g. Inventarni broj: P-51285.

TABLA 20*Sonda 2, sloj 4*

1. Uvučeni obod. Usna ukrašena utiscima noktom. Smeđa keramika s primjesama sitnih kamenčića. Dimenzije: 59,2 x 40,7 x 6,2 mm. Težina: 20,51 g. Inventarni broj: P-51284.
2. Ravni obod. Usna ukrašena utiscima noktom. Žutosmeđa keramika s primjesama sitnih kamenčića i pijeska. Dimenzije: 55,6 x 55,2 x 7,0 mm. Težina: 34,92 g. Inventarni broj: P-51263.
3. Uvučeni obod. Usna je zadebljana s vanjske strane i ukrašena utiscima noktom. Smeđa keramika. Ispod oboda red utisaka prstom. Dimenzije: 79,3 x 61,8 x 11,1 mm. Težina: 68,05 g. Inventarni broj: P-51282.
4. Izvijeni obod. Usna ukrašena utiscima prstom. Mrljasta (smeđa i siva) keramika s primjesama pijeska. Ispod oboda nalazi se plastična traka ukrašena utiscima noktom. Dimenzije: 70,3 x 47,0 x 7,7 mm. Težina: 48,57 g. Inventarni broj: P-51276.
5. Uvučeni obod. Usna ukrašena utiscima prstom. Mrljasta (smeđa i siva) keramika s primjesama pijeska. Metličasto obrađena vanjska i unutrašnja površina stijenke. Ispod oboda nalazi se plastična traka ukrašena utiscima prstom. Dimenzije: 106,0 x 98,1 x 8,8 mm. Težina: 158,26 g. Inventarni broj: P-51281.

TABLA 21*Sonda 2, sloj 4*

1. Dva ulomka istog tanjurića koji se ne spajaju. Mrljasta (smeđa i tamnosiva) keramika s primjesama pijeska. Dimenzije većeg ulomka: 64,9 x 33,1 x 7,7 mm. Težina većeg ulomka: 13,78 g. Dimenzije manjeg ulomka: 45,4 x 34,0 x 8,3 mm. Težina manjeg ulomka: 10,03 g. Inventarni broj: P-51255.
2. Uvučeni obod. Usna ukrašena utiscima noktom. Izvana smeđa, iznutra crna keramika. Metličasto

pebble grit and sand. Brushed outer wall surface. Dimensions: 50.5 x 29.0 x 6.4 mm. Weight: 15.09 g. Inventory Number: P-51270.

10. An everted rim. The lip is decorated with nail impressions. Flecked (brown and black) pottery. Brushed outer wall surface. Dimensions: 51.3 x 41.1 x 7.6 mm. Weight: 26.43 g. Inventory Number: P-51271.
11. A drawn in rim. The lip is decorated with finger impressions. Grey pottery. Located underneath the rim is a plastic strap decorated with finger impressions. Dimensions: 61.7 x 51.5 x 8.8 mm. Weight: 45.82 g. Inventory Number: P-51285.

TABLA 20*Probe 2, layer 4*

1. A drawn in rim. The lip is decorated with nail impressions. Brown pottery tempered with pebble grit. Dimensions: 59.2 x 40.7 x 6.2 mm. Weight: 20.51 g. Inventory Number: P-51284.
2. A flat rim. The lip is decorated with nail impressions. Yellow-brown pottery tempered with pebble grit and sand. Dimensions: 55.6 x 55.2 x 7.0 mm. Weight: 34.92 g. Inventory Number: P-51263.
3. A drawn in rim. The lip is thickened on the outer side and decorated with nail impressions. Brown pottery. Located underneath the rim is a row of finger impressions. Dimensions: 79.3 x 61.8 x 11.1 mm. Weight: 68.05 g. Inventory Number: P-51282.
4. An everted rim. The lip is decorated with finger impressions. Flecked (brown and grey) pottery tempered with sand. Located underneath the rim is a plastic strap decorated with nail impressions. Dimensions: 70.3 x 47.0 x 7.7 mm. Weight: 48.57 g. Inventory Number: P-51276.
5. A drawn in rim. The lip is decorated with finger impressions. Flecked (brown and grey) pottery tempered with sand. Brushed outer and inner wall surface. Located underneath the rim is a plastic strap decorated with finger impressions. Dimensions: 106.0 x 98.1 x 8.8 mm. Weight: 158.26 g. Inventory Number: P-51281.

TABLA 21*Probe 2, layer 4*

1. Two fragments of the same small plate, which cannot be joined. Flecked (brown and dark grey) pottery tempered with sand. Dimensions of the larger fragment: 64.9 x 33.1 x 7.7 mm. Weight of the larger fragment: 13.78 g. Dimensions of the smaller fragment: 45.4 x 34.0 x 8.3 mm. Weight of the smaller fragment: 10.03 g. Inventory Number: P-51255.

- obrađena vanjska i unutrašnja površina stijenke. Dimenzije: 68,7 x 56,6 x 7,0 mm. Težina: 27,79 g. Inventarni broj: P-51279.
3. Obod i velik dio tijela duboke zdjele. Mrljasta (smeđa i crna) keramika s primjesama pijeska. Glačana vanjska i unutrašnja površina stijenke. Dimenzije: 115,2 x 84,7 x 7,1 mm. Težina: 96,67 g. Inventarni broj: P-51257.
 4. Izvijeni obod, vrat i trbuh posude. Usna oboda ukrašena urezima noktom. Smeđa keramika s primjesama sitnih kamenčića i pijeska. Metličasto obrađena vanjska površina stijenke. Sačuvana jedna bradavica izvedena štipanjem. Dimenzije: 116,7 x 78,7 x 6,9 mm. Težina: 78,43 g. Inventarni broj: P-51117.

TABLA 22**Sonda 2, sloj 4**

1. Izvijeni obod i vrat posude. Mrljasta (crvenkastosmeđa i tamnosiva) keramika s primjesama pijeska. Metličasto obrađena vanjska i unutrašnja površina stijenke. Dimenzije: 164,0 x 79,0 x 5,9 mm. Težina: 98,22 g. Inventarni broj: P-51114.
2. Izvijeni obod i vrat posude. Crna keramika s primjesama pijeska. Glačana vanjska i unutrašnja površina stijenke. Okomite, plitke kanelure koje se kreću od vrata prema trbuhu. Dimenzije: 90,0 x 70,0 x 8,0 mm. Težina: 67,7 g. Inventarni broj: P-51116.
3. Izvijeni obod i vrat posude. Sivosmeđa keramika s primjesama sitnih kamenčića. Metličasto obrađena vanjska površina stijenke. Dimenzije: 87,0 x 78,5 x 8,0 mm. Težina: 66,05 g. Inventarni broj: P-51266.
4. Izvijeni obod, vrat i trbuh posude. Usna ukrašena utiscima noktom. Mrljasta (smeđa i siva) keramika s primjesama sitnih kamenčića i pijeska. Metličasto obrađena vanjska površina stijenke. Dimenzije: 134,4 x 91,0 x 7,2 mm. Težina: 108,65 g. Inventarni broj: P-51272.

TABLA 23**Sonda 2, sloj 4**

1. Uvučeni obod. Sivosmeđa keramika s primjesama pijeska. Metličasto obrađena vanjska površina stijenke. Dimenzije: 113,5 x 109,2 x 7,7 mm. Težina: 34,92 g. Inventarni broj: P-51263.
2. Dva ulomka istog izvijenog oboda koji se ne mogu spojiti. Usna ukrašena utiscima noktom. Smeđa keramika. Metličasto obrađena vanjska i unutrašnja površina stijenke. Dimenzije većeg ulomka: 115,5 x 66,0 x 7,4 mm. Težina većeg ulomka: 98,58 g. Dimenzije manjeg ulomka: 64,3 x 37,7 x 7,6 mm.

2. A drawn in rim. The lip is decorated with nail impressions. Brown pottery on the outside, black on the inside. Brushed outer and inner wall surface. Dimensions: 68.7 x 56.6 x 7.0 mm. Weight: 27.79 g. Inventory Number: P-51279.
3. The rim and a large section of the body of a deep bowl. Flecked (brown and black) pottery tempered with sand. Burnished outer and inner wall surface. Dimensions: 115.2 x 84.7 x 7.1 mm. Weight: 96.67 g. Inventory Number: P-51257.
4. An everted rim, neck and belly of a vessel. The lip of the rim is decorated with nail incisions. Brown pottery tempered with pebble grit and sand. Brushed outer wall surface. A single nub executed by pinching is preserved. Dimensions: 116.7 x 78.7 x 6.9 mm. Weight: 78.43 g. Inventory Number: P-51117.

TABLA 22**Probe 2, layer 4**

1. An everted rim and neck of a vessel. Flecked (reddish-brown and dark grey) pottery tempered with sand. Brushed outer and inner wall surface. Dimensions: 164.0 x 79.0 x 5.9 mm. Weight: 98.22 g. Inventory Number: P-51114.
2. An everted rim and neck of a vessel. Black pottery tempered with sand. Burnished outer and inner wall surface. Vertical, shallow channels run from the neck towards the belly. Dimensions: 90.0 x 70.0 x 8.0 mm. Weight: 67.7 g. Inventory Number: P-51116.
3. An everted rim and neck of a vessel. Grey-brown pottery tempered with pebble grit. Brushed outer wall surface. Dimensions: 87.0 x 78.5 x 8.0 mm. Weight: 66.05 g. Inventory Number: P-51266.
4. An everted rim, neck and belly of a vessel. The lip is decorated with nail impressions. Flecked (brown and grey) pottery tempered with pebble grit and sand. Brushed outer wall surface. Dimensions: 134.4 x 91.0 x 7.2 mm. Weight: 108.65 g. Inventory Number: P-51272.

TABLA 23**Probe 2, layer 4**

1. A drawn in rim. Grey-brown pottery tempered with sand. Brushed outer wall surface. Dimensions: 113.5 x 109.2 x 7.7 mm. Weight: 34.92 g. Inventory Number: P-51263.
2. Two fragments of the same everted rim, which cannot be joined. The lip is decorated with nail impressions. Brown pottery. Brushed outer and inner wall surface. Dimensions of the larger

Težina manjeg ulomka: 29,66 g. Inventarni broj: P-51275.

3. Izvijeni obod i vrat posude. Usna ukrašena utiscima noptom. Izvana mrljasta (smeđa i tamnosiva), iznutra smeđa keramika s primjesama pijeska. Metličasto obrađena vanjska i unutrašnja površina stijenke. Dimenzije: 152,7 x 130,8 x 7,6 mm. Težina: 224,04. Inventarni broj: P-51113.

TABLA 24

Sonda 2, sloj 4

1. Posuda s ravnim, uskim obodom, kratkim vratom i bikoničnim, zdepastim tijelom, rekonstruirana na temelju 12 ulomaka koji su se mogli spojiti od oboda do gotovo samog dna. Mrljasta (smeđa, tamnosmeđa i crna) keramika s primjesama pijeska. Dno je izvedeno da bi posuda lakše stajala i na temelju drugih nalaza. Na ulomcima je ostao sačuvan dio okomite ušice izvedene s unutrašnje strane stijenke. Dimenzije posude s improviziranim dnom: 131,6 x 123,5 x 5,1 mm. Težina posude s improviziranim dnom: 700,0 g. Inventarni broj: P-51308.
2. Posuda s ravnim, širokim obodom i bikoničnim tijelom, rekonstruirana na temelju četiri ulomka koji su se mogli spojiti od oboda do ravnog dna i još dva koji su dio iste posude. Mrljasta (smeđa i crna) keramika s primjesama pijeska. Dimenzije rekonstruirane posude: 100,0 x 145,1 x 5,1 mm. Težina rekonstruirane posude: 400,0 g. Inventarni broj: P-51309.
3. Ravno dno. Izvana tamnosiva, iznutra smeđa kreamika s primjesama pijeska. Stijenka nije očuvana. Dimenzije: 25,9 x 23,8 x 10,0 mm. Težina: 5,99 g. Inventarni broj: P-51288.
4. Ravno dno. Tamnosiva keramika s primjesama pijeska. Stijenka je ravna. Dimenzije: 26,9 x 21,8 x 7,1 mm. Težina: 4,94 g. Inventarni broj: P-51110.
5. Ravno dno na peticu. Siva keramika. Stijenka je ravna. Dimenzije: 35,0 x 18,4 x 8,7 mm. Težina: 6,16 g. Inventarni broj: P-51287.
6. Ravno dno. Siva keramika. Stijenka je ravna. Dimenzije: 28,8 x 19,5 x 8,0 mm. Težina: 4,06 g. Inventarni broj: P-51292.
7. Ravno dno i najveći sačuvani ulomak stijenke iste posude. Postoji još 18 neodredivih ulomaka iste posude koji se ne spajaju. Tamnosiva keramika s primjesama pijeska. Dimenzije dna: 22,2 x 21,0 x 4,6 mm. Težina: 2,87 g. Dimenzije ulomka stijenke: 83,6 x 64,8 x 4,9 mm. Težina: 42,84 g. Inventarni broj: P-51307.

fragment: 115.5 x 66.0 x 7.4 mm. Weight of the larger fragment: 98.58 g. Dimensions of the smaller fragment: 64.3 x 37.7 x 7.6 mm. Weight of the smaller fragment: 29.66 g. Inventory Number: P-51275.

3. An everted rim and neck of a vessel. The lip is decorated with nail impressions. Flecked (brown and dark grey) pottery on the outside, brown on the inside, tempered with sand. Brushed outer and inner wall surface. Dimensions: 152.7 x 130.8 x 7.6 mm. Weight: 224.04. Inventory Number: P-51113.

TABLA 24

Probe 2, layer 4

1. A vessel with a flat, narrow rim, a short neck, and a carinated, squat body, which was reconstructed out of 12 fragments that could be joined from the rim almost to the base. Flecked (brown, dark grey and black) pottery tempered with sand. The base was executed so as to ensure the stability of the vessel, and also on the basis of other finds. A section of the vertical lug is still preserved on the fragments, which was executed on the inner side of the wall. Dimensions of the vessel with the improvised base: 131.6 x 123.5 x 5.1 mm. Weight of the vessel with the improvised base: 700.0 g. Inventory Number: P-51308.
2. A vessel with a flat, broad rim, and a carinated body, which was reconstructed out of 4 fragments that could be joined from the rim to the flat base, and another 2 that belong to the same vessel. Flecked (brown and black) pottery tempered with sand. Dimensions of the reconstructed vessel: 100.0 x 145.1 x 5.1 mm. Weight of the reconstructed vessel: 400.0 g. Inventory Number: P-51309.
3. A flat base. Dark grey pottery on the outside, brown on the inside, tempered with sand. The wall is not preserved. Dimensions: 25.9 x 23.8 x 10.0 mm. Weight: 5.99 g. Inventory Number: P-51288.
4. A flat base. Dark grey pottery tempered with sand. The wall is flat. Dimensions: 26.9 x 21.8 x 7.1 mm. Weight: 4.94 g. Inventory Number: P-51110.
5. A flat heel-base. Grey pottery. The wall is flat. Dimensions: 35.0 x 18.4 x 8.7 mm. Weight: 6.16 g. Inventory Number: P-51287.
6. A flat base. Grey pottery. The wall is flat. Dimensions: 28.8 x 19.5 x 8.0 mm. Weight: 4.06 g. Inventory Number: P-51292.
7. A flat base and the largest preserved wall fragment of the same vessel. There are another 18 undefined fragments of the same vessel, which cannot be joined. Dark grey pottery tempered with sand.

8. Ravno dno. Izvana smeđa, iznutra siva keramika s primjesama pijeska. Stijenka je ravna i metličasto obrađena na vanjskoj površini. Dimenzije: 40,9 x 19,7 x 7,5 mm. Težina: 11,05 g. Inventarni broj: P-51291.
9. Ravno dno. Siva keramika. Stijenka je ravna i metličasto obrađena na vanjskoj površini. Dimenzije: 45,6 x 21,7 x 8,2 mm. Težina: 16,67 g. Inventarni broj: P-51295.
10. Zaobljeno dno. Smeđa keramika. Stijenka je ravna. Dimenzije: 25,0 x 24,4 x 7,2 mm. Težina: 7,45 g. Inventarni broj: P-51136.
11. Ravno dno. Izvana smeđa, iznutra siva keramika s primjesama pijeska. Stijenka je ravna i metličasto obrađena na vanjskoj površini. Dimenzije: 39,9 x 37,0 x 9,5 mm. Težina: 19,55 g. Inventarni broj: P-51103.
12. Ravno dno. Smeđa keramika s primjesama pijeska. Stijenka je ravna. Dimenzije: 37,0 x 30,5 x 11,6 mm. Težina: 19,06 g. Inventarni broj: P-51289.
13. Ravno dno. Smeđa keramika s primjesama sitnih kamenčića i pijeska. Stijenka je ravna i metličasto obrađena na vanjskoj površini. Dimenzije: 41,8 x 34,8 x 7,4 mm. Težina: 18,55 g. Inventarni broj: P-51293.
14. Ravno dno. Izvana smeđa, iznutra crna keramika s primjesama pijeska. Stijenka je ravna. Dimenzije: 57,0 x 33,0 x 7,7 mm. Težina: 18,87 g. Inventarni broj: P-51296.

TABLA 25

Sonda 2, sloj 4

1. Ravno dno. Izvana smeđa, iznutra tamnosiva keramika s primjesama pijeska. Stijenka je ravna. Dimenzije: 55,7 x 45,2 x 9,9 mm. Težina: 32,18 g. Inventarni broj: P-51294.
2. Ravno dno s peticom. Siva keramika. Stijenka je ravna. Dimenzije: 109,1 x 51,5 x 8,0 mm. Težina: 70,25 g. Inventarni broj: P-51297.
3. Ravno dno s peticom. Izvana smeđa, iznutra mrljasta (smeđa i tamnosiva) keramika s primjesama sitnih kamenčića. Stijenka je ravna i metličasto obrađena na vanjskoj površini. Dimenzije: 104,3 x 81,0 x 8,2 mm. Težina: 93,5 g. Inventarni broj: P-51290.
4. Ravno dno. Sivosmeđa keramika s primjesama pijeska. Stijenka je ravna. Dimenzije: 69,8 x 48,0 x 6,7 mm. Težina: 30,81 g. Inventarni broj: P-51135.
5. Ravno dno. S vanjske strane na dnu je utisnut konop ili predmet koji ostavlja sličan trag. Smeđa keramika. Stijenka je ravna. Dimenzije: 42,0 x 21,9 x 7,0 mm. Težina: 15,99 g. Inventarni broj: P-51107.
6. Ravno dno na peticu. S vanjske strane na dnu je spiralno utisnut konop ili predmet koji ostavlja

Dimensions of the base: 22.2 x 21.0 x 4.6 mm. Weight: 2.87 g. Dimensions of the wall fragment: 83.6 x 64.8 x 4.9 mm. Weight: 42.84 g. Inventory Number: P-51307.

8. A flat base. Brown pottery on the outside, grey on the inside, tempered with sand. The wall is flat and brushed on the outer surface. Dimensions: 40.9 x 19.7 x 7.5 mm. Weight: 11.05 g. Inventory Number: P-51291.
9. A flat base. Grey pottery. The wall is flat and brushed on the outer surface. Dimensions: 45.6 x 21.7 x 8.2 mm. Weight: 16.67 g. Inventory Number: P-51295.
10. A rounded base. Brown pottery. The wall is flat. Dimensions: 25.0 x 24.4 x 7.2 mm. Weight: 7.45 g. Inventory Number: P-51136.
11. A flat base. Brown pottery on the outside, grey on the inside, tempered with sand. The wall is flat and brushed on the outer surface. Dimensions: 39.9 x 37.0 x 9.5 mm. Weight: 19.55 g. Inventory Number: P-51103.
12. A flat base. Brown pottery tempered with sand. The wall is flat. Dimensions: 37.0 x 30.5 x 11.6 mm. Weight: 19.06 g. Inventory Number: P-51289.
13. A flat base. Brown pottery tempered with pebble grit and sand. The wall is flat and brushed on the outer surface. Dimensions: 41.8 x 34.8 x 7.4 mm. Weight: 18.55 g. Inventory Number: P-51293.
14. A flat base. Brown pottery on the outside, black on the inside, tempered with sand. The wall is flat. Dimensions: 57.0 x 33.0 x 7.7 mm. Weight: 18.87 g. Inventory Number: P-51296.

TABLA 25

Probe 2, layer 4

1. A flat base. Brown pottery on the outside, dark grey on the inside, tempered with sand. The wall is flat. Dimensions: 55.7 x 45.2 x 9.9 mm. Weight: 32.18 g. Inventory Number: P-51294.
2. A flat heel-base. Grey pottery. The wall is flat. Dimensions: 109.1 x 51.5 x 8.0 mm. Weight: 70.25 g. Inventory Number: P-51297.
3. A flat heel-base. Brown pottery on the outside, flecked (brown and dark grey) on the inside, tempered with pebble grit. The wall is flat and brushed on the outer surface. Dimensions: 104.3 x 81.0 x 8.2 mm. Weight: 93.5 g. Inventory Number: P-51290.
4. A flat base. Grey-brown pottery tempered with sand. The wall is flat. Dimensions: 69.8 x 48.0 x 6.7 mm. Weight: 30.81 g. Inventory Number: P-51135.
5. A flat base. Located on the outer side of the base is an impression made by a rope or some other object that leaves a similar trace. Brown pottery. The wall

sličan trag. Izvana siva, iznutra smeđa keramika s primjesama sitnih kamenčića. Dimenzije: 160,0 x 132,6 x 9,0 mm. Težina: 242,78 g. Inventarni broj: P-51112.

TABLA 26**Sonda 2, sloj 4**

1. Ulomak ručke. Tamnosiva keramika. Glačana površina. Dimenzije: 27,3 x 16,8 x 6,8 mm. Težina: 3,59 g. Inventarni broj: P-51299.
2. Ulomak stijenke posude bikonične zdjele. Očuvan dio ručke. Tamnosiva keramika. Glačana vanjska površina stijenke. Dimenzije: 61,1 x 33,4 x 5,1 mm. Težina: 18,66 g. Inventarni broj: P-51134.
3. Ulomak većeg dijela stijenke bikonične posude. Crna keramika s primjesama sitnih kamenčića. Očuvana okomita ušica izvedena na zadebljanju najšireg dijela trbuha s unutrašnje strane stijenke. Glačana vanjska i unutrašnja površina stijenke. Na najširem dijelu trbuha nanizane su okomite, plitke kanelure. Dimenzije: 113,3 x 67,0 x 5,6 mm. Težina: 66,88 g. Inventarni broj: P-51300.
4. Ulomak stijenke posude. Smeđa keramika. Metličasto obrađena vanjska površina stijenke. Vidljiv ukras ubodima nekim predmetom. Dimenzije: 21,0 x 12,3 x 4,5 mm. Težina: 2,06 g. Inventarni broj: P-51108.
5. Ulomak stijenke posude. Siva keramika. Metličasto obrađena vanjska i unutrašnja površina stijenke. Vidljiv ukras ubodima nekim predmetom. Dimenzije: 47,6 x 34,1 x 6,7 mm. Težina: 16,26 g. Inventarni broj: P-51132.
6. Ulomak stijenke posude. Izvana mrljasta (smeđa i tamnosiva), iznutra smeđa keramika. Glačana vanjska i unutrašnja površina stijenke. Dimenzije: 32,3 x 23,2 x 5,9 mm. Težina: 7,81 g. Inventarni broj: P-51105.
7. Ulomak stijenke posude. Siva keramika. Dimenzije: 49,4 x 30,9 x 6,0 mm. Težina: 11,08 g. Inventarni broj: P-51104.
8. Ulomak stijenke posude. Izvana mrljasta (smeđa i crna), iznutra siva keramika. Glačana vanjska površina stijenke. Vidljive okomite, šire kanelure. Dimenzije: 41,3 x 18,5 x 6,4 mm. Težina: 5,36 g. Inventarni broj: P-51131.
9. Ulomak stijenke bikonične posude. Tamnosiva keramika s primjesama sitnih kamenčića. Glačana vanjska površina stijenke. Vidljive dvije ukošene, široke kanelure. Dimenzije: 36,7 x 27,0 x 5,6 mm. Težina: 7,61 g. Inventarni broj: P-51306.

is flat. Dimensions: 42.0 x 21.9 x 7.0 mm. Weight: 15.99 g. Inventory Number: P-51107.

6. A flat heel-base. Located on the outer side of the base is a spiral impression made by a rope or some other object that leaves a similar trace. Grey pottery on the outside, brown on the inside, tempered with pebble grit. Dimensions: 160.0 x 132.6 x 9.0 mm. Weight: 242.78 g. Inventory Number: P-51112.

TABLA 26**Probe 2, layer 4**

1. A fragment of a handle. Dark grey pottery. Burnished surface. Dimensions: 27.3 x 16.8 x 6.8 mm. Weight: 3.59 g. Inventory Number: P-51299.
2. A wall fragment of a carinated vessel. A section of the handle is preserved. Dark grey pottery. Burnished outer wall surface. Dimensions: 61.1 x 33.4 x 5.1 mm. Weight: 18.66 g. Inventory Number: P-51134.
3. A fragment of the larger part of the wall of a carinated vessel. Black pottery tempered with pebble grit. A vertical lug is preserved, which was executed on the thickening of the broadest section of the belly, on the interior side of the wall. Burnished outer and inner wall surface. Located on the broadest section of the belly is a series of vertical, shallow channels. Dimensions: 113.3 x 67.0 x 5.6 mm. Weight: 66.88 g. Inventory Number: P-51300.
4. A fragment of the vessel wall. Brown pottery. Brushed outer wall surface. There is a visible decoration consisting of engraved points made with an unidentified object. Dimensions: 21.0 x 12.3 x 4.5 mm. Weight: 2.06 g. Inventory Number: P-51108.
5. A fragment of the vessel wall. Grey pottery. Brushed outer and inner wall surface. There is a visible decoration consisting of engraved points made with an unidentified object. Dimensions: 47.6 x 34.1 x 6.7 mm. Weight: 16.26 g. Inventory Number: P-51132.
6. A fragment of the vessel wall. Flecked (brown and dark grey) pottery on the outside, brown on the inside. Burnished outer and inner wall surface. Dimensions: 32.3 x 23.2 x 5.9 mm. Weight: 7.81 g. Inventory Number: P-51105.
7. A fragment of the vessel wall. Grey pottery. Dimensions: 49.4 x 30.9 x 6.0 mm. Weight: 11.08 g. Inventory Number: P-51104.
8. A fragment of the vessel wall. Flecked (brown and black) pottery on the outside, grey on the inside. Burnished outer wall surface. There are broader vertical channels that are visible. Dimensions: 41.3 x 18.5 x 6.4 mm. Weight: 5.36 g. Inventory Number: P-51131.
9. A wall fragment of a carinated vessel. Dark grey pottery tempered with pebble grit. Burnished outer

10. Ulomak vrata i trbuha posude. Crna keramika s primjesama pijeska. Glačana vanjska i unutrašnja površina stijenke. Na najširem dijelu trbuha nalazi se niz okomitih, plitkih kanelura. Dimenzije: 49,8 x 33,5 x 5,9 mm. Težina: 14,63 g. Inventarni broj: P-51303.
 11. Ulomak stijenke posude. Izvana mrljasta (smeđa i crna), iznutra siva keramika. Glačana vanjska površina stijenke. Vidljive okomite, šire kanelure. Dimenzije: 43,9 x 23,9 x 4,6 mm. Težina: 6,44 g. Inventarni broj: P-51129.
 12. Ulomak stijenke posude. Izvana mrljasta (smeđa i crna), iznutra tamnosiva keramika. Glačana vanjska površina stijenke. Vidljive okomite, šire kanelure. Dimenzije: 49,7 x 49,2 x 7,5 mm. Težina: 19,17 g. Inventarni broj: P-51130.
 13. Ulomak vrata i trbuha posude. Izvana tamnosiva, iznutra smeđa keramika s primjesama pijeska. Glačana vanjska i unutrašnja površina stijenke. Na najširem dijelu trbuha nalazi se niz ukošenih, plitkih kanelura. Dimenzije: 50,5 x 35,6 x 5,4 mm. Težina: 10,53 g. Inventarni broj: P-51304.
 14. Ulomak stijenke posude. Tamnosiva keramika. Glačana vanjska površina stijenke. Vidljivo nekoliko okomitih, plitkih kanelura. Dimenzije: 60,3 x 43,1 x 5,7 mm. Težina: 20,84 g. Inventarni broj: P-51301.
- wall surface. There are two broad, slanted channels that are visible. Dimensions: 36.7 x 27.0 x 5.6 mm. Weight: 7.61 g. Inventory Number: P-51306.
10. A fragment of the neck and belly of a vessel. Black pottery tempered with sand. Burnished outer and inner wall surface. Located on the broadest section of the belly is a series of vertical, shallow channels. Dimensions: 49.8 x 33.5 x 5.9 mm. Weight: 14.63 g. Inventory Number: P-51303.
 11. A fragment of the vessel wall. Flecked (brown and black) pottery on the outside, grey on the inside. Burnished outer wall surface. There are broad, vertical channels that are visible. Dimensions: 43.9 x 23.9 x 4.6 mm. Weight: 6.44 g. Inventory Number: P-51129.
 12. A fragment of the vessel wall. Flecked (brown and black) pottery on the outside, dark grey on the inside. Burnished outer wall surface. There are broader, vertical channels that are visible. Dimensions: 49.7 x 49.2 x 7.5 mm. Weight: 19.17 g. Inventory Number: P-51130.
 13. A fragment of the neck and belly of a vessel. Dark grey pottery on the outside, brown on the inside, tempered with sand. Burnished outer and inner wall surface. Located on the broadest section of the belly is a series of shallow, slanted channels. Dimensions: 50.5 x 35.6 x 5.4 mm. Weight: 10.53 g. Inventory Number: P-51304.
 14. A fragment of the vessel wall. Dark grey pottery. Burnished outer wall surface. Several shallow, vertical channels are visible. Dimensions: 60.3 x 43.1 x 5.7 mm. Weight: 20.84 g. Inventory Number: P-51301.

TABLA 27

Sonda 2, sloj 4

1. Ulomak stijenke posude. Mrljasta (smeđa i tamnosiva) keramika. Glačana vanjska površina stijenke. Vidljivo nekoliko širokih kanelura izvedenih prstima. Dimenzije: 61,6 x 50,3 x 7,3 mm. Težina: 30,18 g. Inventarni broj: P-51302.
2. Ulomak stijenke bikonične posude. Crna keramika s primjesama pijeska. Glačana vanjska i unutrašnja površina stijenke. Na najširem dijelu trbuha naziru se šire kanelure. Dimenzije: 63,5 x 54,0 x 5,7 mm. Težina: 25,14 g. Inventarni broj: P-51305.
3. Ulomak stijenke s dijelom rupice za krpanje. Siva keramika s primjesama sitnih kamenčića i pijeska. Dimenzije: 33,0 x 14,4 x 6,4 mm. Težina: 4,17 g. Inventarni broj: P-51298.
4. Ulomak stijenke posude u blizini dna. Izvana smeđa, iznutra mrljasta (tamnosiva i smeđa) keramika s primjesama pijeska. Metličasto obrađena vanjska površina stijenke. Dimenzije: 175,1 x 90,7 x 6,3 mm. Težina: 190,21 g. Inventarni broj: P-51115.

TABLA 27

Probe 2, layer 4

1. A fragment of the vessel wall. Flecked (brown and dark grey) pottery. Burnished outer wall surface. Several broad channels executed with fingers are visible. Dimensions: 61.6 x 50.3 x 7.3 mm. Weight: 30.18 g. Inventory Number: P-51302.
2. A fragment of the wall of a carinated vessel. Black pottery tempered with sand. Burnished outer and inner wall surface. Wider channels can be discerned on the broadest section of the belly. Dimensions: 63.5 x 54.0 x 5.7 mm. Weight: 25.14 g. Inventory Number: P-51305.
3. A wall fragment with part of a perforation intended for mending. Grey pottery tempered with pebble grit and sand. Dimensions: 33.0 x 14.4 x 6.4 mm. Weight: 4.17 g. Inventory Number: P-51298.
4. A fragment of the vessel wall in the vicinity of the base. Brown pottery on the outside, flecked

Sonda 2, tvorevina 4

5. Izvijeni obod. Izvana crna, iznutra mrljasta (crna i crvena) keramika. Glačana vanjska površina stijenke. Dimenzije: 80,0 x 54,3 x 7,0 mm. Težina: 45,39 g. Inventarni broj: P-51342.
6. Ravni obod. Usna ukrašena utiscima noktom. Mrljasta (tamnosiva i sivosmeđa) keramika s primjesama pijeska. Metličasto obrađena vanjska i unutrašnja površina stijenke. Dimenzije: 38,6 x 26,2 x 6,1 mm. Težina: 12,76 g. Inventarni broj: P-51345.
7. Uvučeni obod. Usna ukrašena utiscima noktom. Izvana smeđa, iznutra crna keramika s primjesama pijeska. Metličasto obrađena vanjska površina stijenke. Dimenzije: 42,7 x 37,3 x 6,8 mm. Težina: 16,25 g. Inventarni broj: P-51344.
8. Izvijeni obod. Usna ukrašena utiscima prstom. Mrljasta (tamnosiva i smeđa) keramika s primjesama pijeska. Metličasto obrađena vanjska površina stijenke. Dimenzije: 58,9 x 37,6 x 8,6 mm. Težina: 31,96 g. Inventarni broj: P-51343.
9. Ravno dno. Sivosmeđa keramika s primjesama sitnih kamenčića. Stijenka je ravna i metličasto obrađena na vanjskoj površini. Dimenzije: 54,1 x 41,1 x 14,8 mm. Težina: 53,76 g. Inventarni broj: P-51346.

TABLA 28**Sonda 2, tvorevina 4**

1. Ulomak stijenke posude s ukrasom izvedenim utiskivanjem noktom. Smeđa keramika s primjesama sitnih kamenčića i pijeska. Metličasto obrađena vanjska površina stijenke. Dimenzije: 66,7 x 45,9 x 8,7 mm. Težina: 39,82 g. Inventarni broj: P-51348.
2. Ulomak predmeta nepozate namjene. Siva keramika s primjesama pijeska. Ukrašen šrafiranim trokutićima. Sačuvana je ušica. Dimenzije: 44,2 x 27,4 x 7,1 mm. Težina: 20,41 g. Inventarni broj: P-51347.

Sonda 2, sloj 6

3. Izvijeni obod. Izvana smeđa, iznutra crna keramika s primjesama pijeska. Dimenzije: 31,1 x 19,2 x 6,3 mm. Težina: 6,24 g. Inventarni broj: P-51171.
4. Uvučeni obod. Mrljasta (smeđa i crna) keramika. Dimenzije: 48,5 x 32,3 x 6,0 mm. Težina: 13,36 g. Inventarni broj: P-51121.
5. Izvijeni obod. Tamnosmeđa keramika s primjesama sitnih kamenčića. Metličasto obrađena vanjska

(dark grey and brown) on the inside, tempered with sand. Brushed outer wall surface. Dimensions: 175.1 x 90.7 x 6.3 mm. Weight: 190.21 g. Inventory Number: P-51115.

Probe 2, feature 4

5. An everted rim. Black pottery on the outside, flecked (black and red) on the inside. Burnished outer wall surface. Dimensions: 80.0 x 54.3 x 7.0 mm. Weight: 45.39 g. Inventory Number: P-51342.
6. A flat rim. The lip is decorated with nail impressions. Flecked (dark grey and grey-brown) pottery tempered with sand. Brushed outer and inner wall surface. Dimensions: 38.6 x 26.2 x 6.1 mm. Weight: 12.76 g. Inventory Number: P-51345.
7. A drawn in rim. The lip is decorated with nail impressions. Brown pottery on the outside, black on the inside, tempered with sand. Brushed outer wall surface. Dimensions: 42.7 x 37.3 x 6.8 mm. Weight: 16.25 g. Inventory Number: P-51344.
8. An everted rim. The lip is decorated with finger impressions. Flecked (dark grey and brown) pottery tempered with sand. Brushed outer wall surface. Dimensions: 58.9 x 37.6 x 8.6 mm. Weight: 31.96 g. Inventory Number: P-51343.
9. A flat base. Grey-brown pottery tempered with pebble grit. The wall is flat and brushed on the outer surface. Dimensions: 54.1 x 41.1 x 14.8 mm. Weight: 53.76 g. Inventory Number: P-51346.

TABLA 28**Probe 2, feature 4**

1. A fragment of the vessel wall with a decoration made with nail impressions. Brown pottery tempered with pebble grit and sand. Brushed outer wall surface. Dimensions: 66.7 x 45.9 x 8.7 mm. Weight: 39.82 g. Inventory Number: P-51348.
2. A fragment of an unidentified object. Grey pottery tempered with sand. Decorated with small hatched triangles. A lug is preserved. Dimensions: 44.2 x 27.4 x 7.1 mm. Weight: 20.41 g. Inventory Number: P-51347.

Probe 2, layer 6

3. An everted rim. Brown pottery on the outside, black on the inside, tempered with sand. Dimensions: 31.1 x 19.2 x 6.3 mm. Weight: 6.24 g. Inventory Number: P-51171.
4. A drawn in rim. Flecked (brown and black) pottery. Dimensions: 48.5 x 32.3 x 6.0 mm. Weight: 13.36 g. Inventory Number: P-51121.
5. An everted rim. Dark brown pottery tempered with pebble grit. Brushed outer wall surface. Dimensions:

površina stijenke. Dimenzije: 44,8 x 44,3 x 6,9 mm. Težina: 14,57 g. Inventarni broj: P-51409.

6. Izvijeni obod. Crna keramika s primjesama pijeska. Dimenzije: 27,4 x 25,3 x 4,8 mm. Težina: 2,9 g. Inventarni broj: P-51408.
7. Izvijeni obod. Izvana smeđa, iznutra crna keramika s primjesama sitnih kamenčića i pijeska. Dimenzije: 51,3 x 48,0 x 7,0 mm. Težina: 29,02 g. Inventarni broj: P-51119.
8. Izvijeni obod. Usna ukrašena utiscima prstom. Izvana smeđa, iznutra mrljasta (smeđa i crna) keramika. Metličasto obrađena vanjska i unutrašnja površina stijenke. Dimenzije: 35,1 x 32,3 x 5,4 mm. Težina: 10,27 g. Inventarni broj: P-51120.
9. Ravni obod. Usna ukrašena utiscima prstom. Izvana crvenkastosmeđa, iznutra mrljasta (smeđa i crna) keramika s primjesama pijeska. Ispod oboda nalazi se plastična traka s utiscima prstom. Dimenzije: 41,2 x 31,7 x 13,0 mm. Težina: 24,08 g. Inventarni broj: P-51122.
10. Ravni obod. Usna ukrašena utiscima prstom. Crvenkastosmeđa keramika s primjesama sitnih kamenčića i pijeska. Dimenzije: 51,3 x 39,5 x 8,5 mm. Težina: 21,84 g. Inventarni broj: P-51189.

Sonda 2, tvorevina 5

11. Ulomak stijenke posude na čijem se jednom dijelu vidi red utisaka noktom ili nekim predmetom te nekoliko tankih, plitkih ureza. Sivosmeđa keramika s primjesama pijeska. Dimenzije: 25,0 x 21,5 x 6,0 mm. Težina: 3,56 g. Inventarni broj: P-51195.

Sonda 2, sloj 7

12. Ravni obod. Crna keramika s primjesama sitnih kamenčića i pijeska. Dimenzije: 20,9 x 16,3 x 6,5 mm. Težina: 2,43 g. Inventarni broj: P-51175.
13. Ravni obod. Crna keramika s primjesama pijeska. Dimenzije: 29,2 x 28,5 x 5,0 mm. Težina: 4,44 g. Inventarni broj: P-51176.
14. Ravni obod. Siva keramika s primjesama pijeska. Dimenzije: 22,4 x 19,9 x 5,0 mm. Težina: 3,02 g. Inventarni broj: P-51174.
15. Ravni obod. Crna keramika s primjesama sitnih kamenčića i pijeska. Ispod oboda nalaze se dvije urezane, paralelne linije koje prate liniju oboda. Dimenzije: 22,9 x 21,5 x 5,6 mm. Težina: 3,43 g. Inventarni broj: P-51173.
16. Ravni obod. Siva keramika s primjesama pijeska. Dimenzije: 45,7 x 28,5 x 5,9 mm. Težina: 10,5 g. Inventarni broj: P-51399.

44.8 x 44.3 x 6.9 mm. Weight: 14.57 g. Inventory Number: P-51409.

6. An everted rim. Black pottery tempered with sand. Dimensions: 27.4 x 25.3 x 4.8 mm. Weight: 2.9 g. Inventory Number: P-51408.
7. An everted rim. Brown pottery on the outside, black on the inside, tempered with pebble grit and sand. Dimensions: 51.3 x 48.0 x 7.0 mm. Weight: 29.02 g. Inventory Number: P-51119.
8. An everted rim. The lip is decorated with finger impressions. Brown pottery on the outside, flecked (brown and black) on the inside. Brushed outer and inner wall surface. Dimensions: 35.1 x 32.3 x 5.4 mm. Weight: 10.27 g. Inventory Number: P-51120.
9. A flat rim. The lip is decorated with finger impressions. Reddish-brown pottery on the outside, flecked (brown and black) on the inside, tempered with sand. Located underneath the rim is a plastic strap with finger impressions. Dimensions: 41.2 x 31.7 x 13.0 mm. Weight: 24.08 g. Inventory Number: P-51122.
10. A flat rim. The lip is decorated with finger impressions. Reddish-brown pottery tempered with pebble grit and sand. Dimensions: 51.3 x 39.5 x 8.5 mm. Weight: 21.84 g. Inventory Number: P-51189.

Probe 2, feature 5

11. A fragment of the vessel wall, visible on one part of which is a row of impressions made with a nail or some other object, and several thin, shallow incisions. Grey-brown pottery tempered with sand. Dimensions: 25.0 x 21.5 x 6.0 mm. Weight: 3.56 g. Inventory Number: P-51195.

Probe 2, layer 7

12. A flat rim. Black pottery tempered with pebble grit and sand. Dimensions: 20.9 x 16.3 x 6.5 mm. Weight: 2.43 g. Inventory Number: P-51175.
13. A flat rim. Black pottery tempered with sand. Dimensions: 29.2 x 28.5 x 5.0 mm. Weight: 4.44 g. Inventory Number: P-51176.
14. A flat rim. Grey pottery tempered with sand. Dimensions: 22.4 x 19.9 x 5.0 mm. Weight: 3.02 g. Inventory Number: P-51174.
15. A flat rim. Black pottery tempered with pebble grit and sand. Located underneath the rim are two incised, parallel lines that follow the line of the rim. Dimensions: 22.9 x 21.5 x 5.6 mm. Weight: 3.43 g. Inventory Number: P-51173.
16. A flat rim. Grey pottery tempered with sand. Dimensions: 45.7 x 28.5 x 5.9 mm. Weight: 10.5 g. Inventory Number: P-51399.

17. Ravni obod. Izvana smeđa, iznutra mrljasta (smeđa i siva) keramika s primjesama pijeska. Dimenzije: 50,5 x 34,0 x 6,3 mm. Težina: 14,45 g. Inventarni broj: P-51400.

TABLA 29

Sonda 2, sloj 7

1. Izvijeni obod. Izvana siva, iznutra smeđa keramika s primjesama sitnih kamenčića i pijeska. Dimenzije: 51,0 x 35,0 x 7,1 mm. Težina: 17,6 g. Inventarni broj: P-51401.
2. Izvijeni obod. Izvana mrljasta (siva i smeđa), iznutra smeđa keramika s primjesama sitnih kamenčića i pijeska. Dimenzije: 50,5 x 43,2 x 7,0 mm. Težina: 25,24 g. Inventarni broj: P-51172.
3. Uvučeni obod. Mrljasta (smeđa i sivosmeđa) keramika s primjesama pijeska. Dimenzije: 60,6 x 59,1 x 8,7 mm. Težina: 45,14 g. Inventarni broj: P-51398.
4. Ravno dno na peticu. Smeđa keramika s primjesama sitnih kamenčića i pijeska. Stijenka je blago zaobljena. Dimenzije: 61,9 x 37,0 x 4,6 mm. Težina: 29,44 g. Inventarni broj: P-51177.
5. Ulomak stijenke posude s ukrasom šrafiranog trokutića. Siva keramika s primjesama pijeska. Dimenzije: 20,3 x 15,7 x 6,2 mm. Težina: 2,15 g. Inventarni broj: P-51180.
6. Ulomak stijenke posude s ukrasom u vidu dva reda utisaka noktom ili nekim predmetom. Siva keramika s primjesama pijeska. Dimenzije: 28,1 x 19,0 x 6,5 mm. Težina: 4,5 g. Inventarni broj: P-51179.
7. Ulomak stijenke posude s plastičnom bradavicom. Crvenkastosmeđa keramika s primjesama sitnih kamenčića i pijeska. Dimenzije: 46,9 x 32,3 x 8,9 mm. Težina: 24,04 g. Inventarni broj: P-51178.

Sonda 2, sloj 8

8. Uvučeni obod. Izvana smeđa, iznutra crna keramika s primjesama pijeska. Dimenzije: 48,8 x 42,7 x 7,6 mm. Težina: 21,89 g. Inventarni broj: P-51340.
9. Ravno dno. Izvana siva, iznutra crna keramika s primjesama sitnih kamenčića i pijeska. Stijenka nije očuvana. Dimenzije: 60,0 x 40,5 x 17,0 mm. Težina: 48,41 g. Inventarni broj: P-51341.

Sonda 2, iz profila

10. Izvijeni obod sa zadebljanjem s vanjske strane. Smeđa keramika s primjesama pijeska. Odlomljena je cijela unutrašnja površina stijenke. Dimenzije:

17. A flat rim. Brown pottery on the outside, flecked (brown and grey) on the inside, tempered with sand. Dimensions: 50.5 x 34.0 x 6.3 mm. Weight: 14.45 g. Inventory Number: P-51400.

TABLE 29

Probe 2, layer 7

1. An everted rim. Grey pottery on the outside, brown on the inside, tempered with pebble grit and sand. Dimensions: 51.0 x 35.0 x 7.1 mm. Weight: 17.6 g. Inventory Number: P-51401.
2. An everted rim. Flecked (grey and brown) pottery on the outside, brown on the inside, tempered with pebble grit and sand. Dimensions: 50.5 x 43.2 x 7.0 mm. Weight: 25.24 g. Inventory Number: P-51172.
3. A drawn in rim. Flecked (brown and grey-brown) pottery tempered with sand. Dimensions: 60.6 x 59.1 x 8.7 mm. Weight: 45.14 g. Inventory Number: P-51398.
4. A flat heel-base. Brown pottery tempered with pebble grit and sand. The wall is slightly rounded. Dimensions: 61.9 x 37.0 x 4.6 mm. Weight: 29.44 g. Inventory Number: P-51177.
5. A fragment of the vessel wall with a decoration consisting of a small hatched triangle. Grey pottery tempered with sand. Dimensions: 20.3 x 15.7 x 6.2 mm. Weight: 2.15 g. Inventory Number: P-51180.
6. A fragment of the vessel wall with a decoration consisting of two rows of impressions made with a nail or some other object. Grey pottery tempered with sand. Dimensions: 28.1 x 19.0 x 6.5 mm. Weight: 4.5 g. Inventory Number: P-51179.
7. A fragment of the vessel wall with a plastic nub. Reddish-brown pottery tempered with pebble grit and sand. Dimensions: 46.9 x 32.3 x 8.9 mm. Weight: 24.04 g. Inventory Number: P-51178.

Probe 2, layer 8

8. A drawn in rim. Brown pottery on the outside, black on the inside, tempered with sand. Dimensions: 48.8 x 42.7 x 7.6 mm. Weight: 21.89 g. Inventory Number: P-51340.
9. A flat base. Grey pottery on the outside, black on the inside, tempered with pebble grit and sand. The wall is not preserved. Dimensions: 60.0 x 40.5 x 17.0 mm. Weight: 48.41 g. Inventory Number: P-51341.

Probe 2, from the profile

10. An everted rim with a thickening on the outer side. Brown pottery tempered with sand. The entire inner surface of the wall was broken off.

25,3 x 17,0 x 3,0 mm. Težina: 1,76 g. Inventarni broj: P-51402.

11. Izvijeni obod. Crna keramika. Glačana vanjska i unutrašnja površina stijenke. Dimenzije: 45,2 x 25,6 x 6,0 mm. Težina: 7,25 g. Inventarni broj: P-51403.
12. Izvijeni obod i vrat posude. Crna keramika. Glačana vanjska i unutrašnja površina stijenke. Na prijelazu s vrata na trbuh nekoliko plitkih, ukošenih kanelura. Dimenzije: 42,3 x 36,7 x 5,6 mm. Težina: 13,46 g. Inventarni broj: P-51404.
13. Ravni obod. Usna ukrašena utiscima noktom. Izvana crna, iznutra smeđa keramika s primjesama pijeska. Dimenzije: 67,5 x 61,0 x 7,3 mm. Težina: 53,03 g. Inventarni broj: P-51405.
14. Ulomak stijenke posude s dvije bradavice izvedene štibanjem. Smeđa keramika s primjesama sitnih kamenčića i pijeska. Dimenzije: 85,5 x 65,9 x 8,5 mm. Težina: 64,16 g. Inventarni broj: P-51406.

Dimensions: 25.3 x 17.0 x 3.0 mm. Weight: 1.76 g. Inventory Number: P-51402.

11. An everted rim. Black pottery. Burnished outer and inner wall surface. Dimensions: 45.2 x 25.6 x 6.0 mm. Weight: 7.25 g. Inventory Number: P-51403.
12. An everted rim and neck of a vessel. Black pottery. Burnished outer and inner wall surface. On the transition from the neck to the belly there are several shallow, slanted channels. Dimensions: 42.3 x 36.7 x 5.6 mm. Weight: 13.46 g. Inventory Number: P-51404.
13. A flat rim. The lip is decorated with nail impressions. Black pottery on the outside, brown on the inside, tempered with sand. Dimensions: 67.5 x 61.0 x 7.3 mm. Weight: 53.03 g. Inventory Number: P-51405.
14. A fragment of the vessel wall with two nubs made by pinching. Brown pottery tempered with pebble grit and sand. Dimensions: 85.5 x 65.9 x 8.5 mm. Weight: 64.16 g. Inventory Number: P-51406.

T. 1.

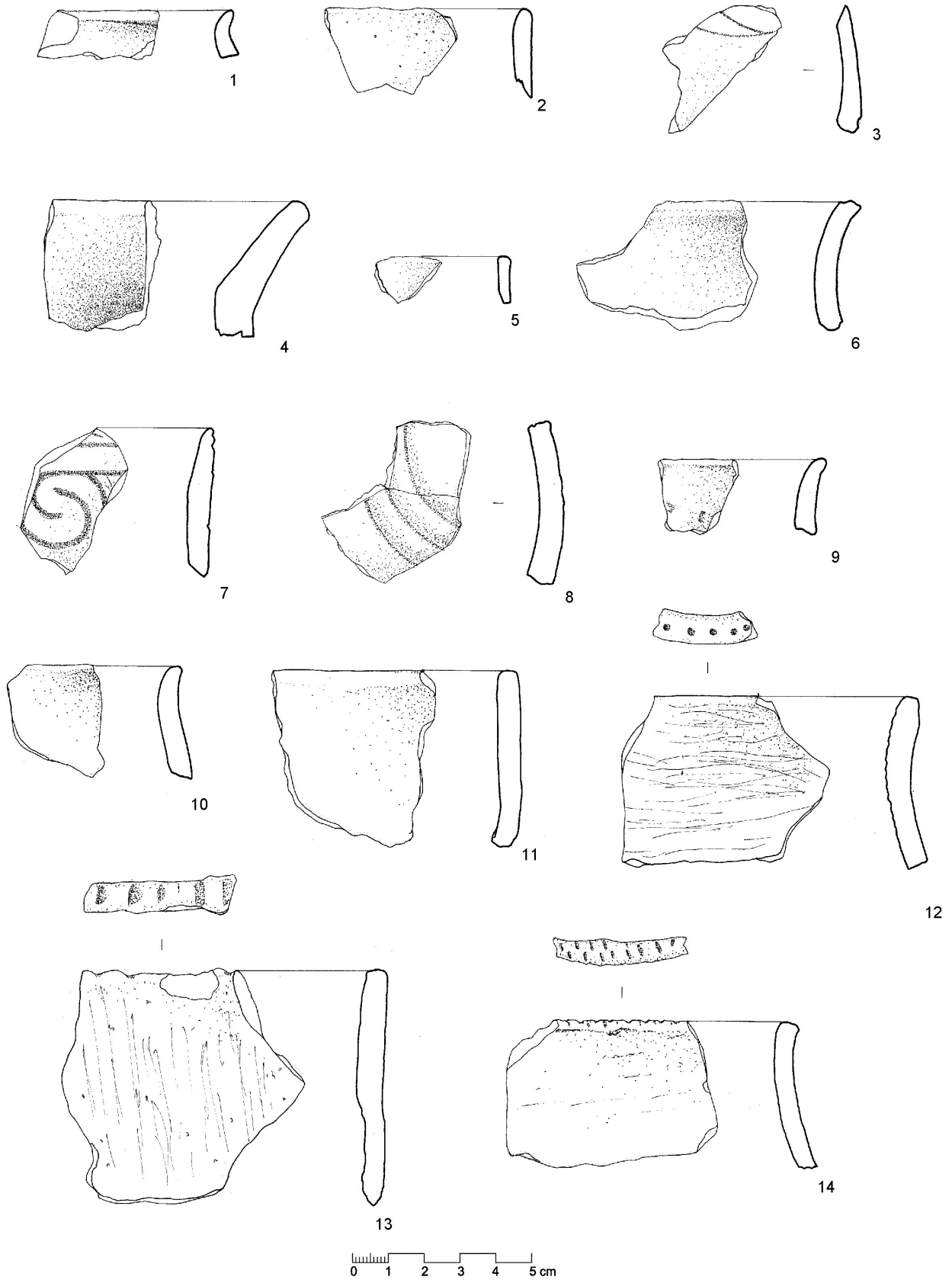

T. 2.

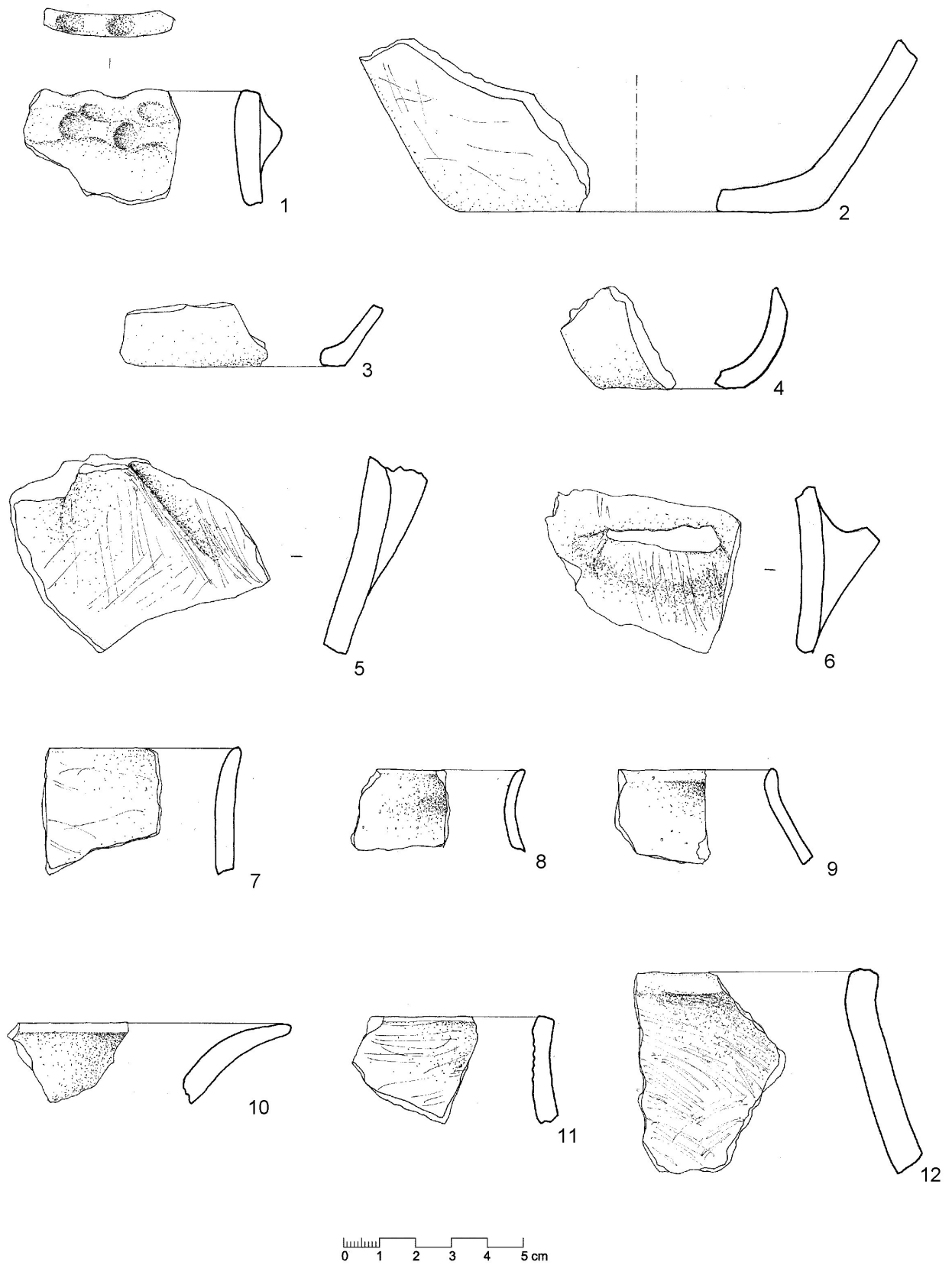

T. 3.

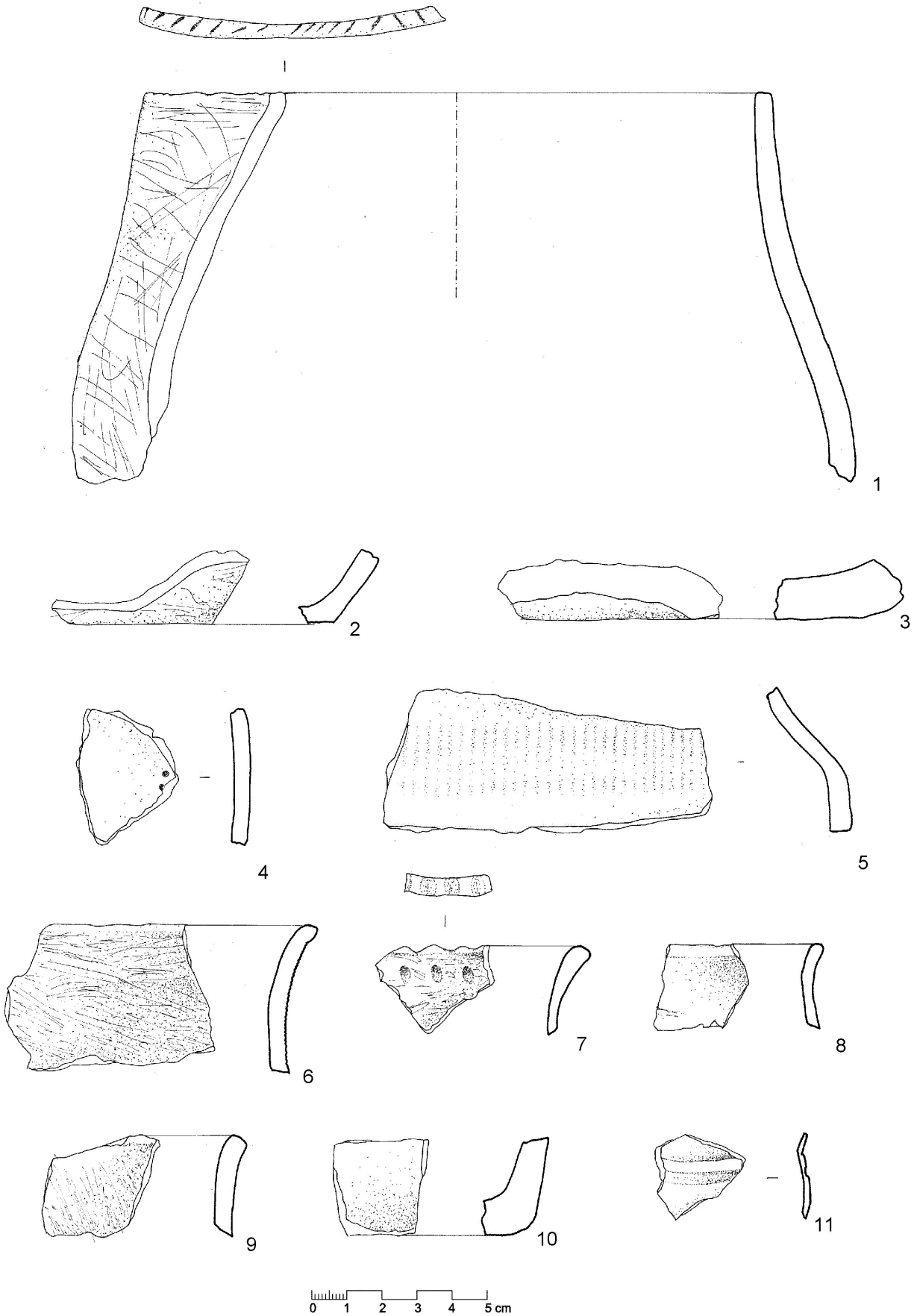

T. 4.

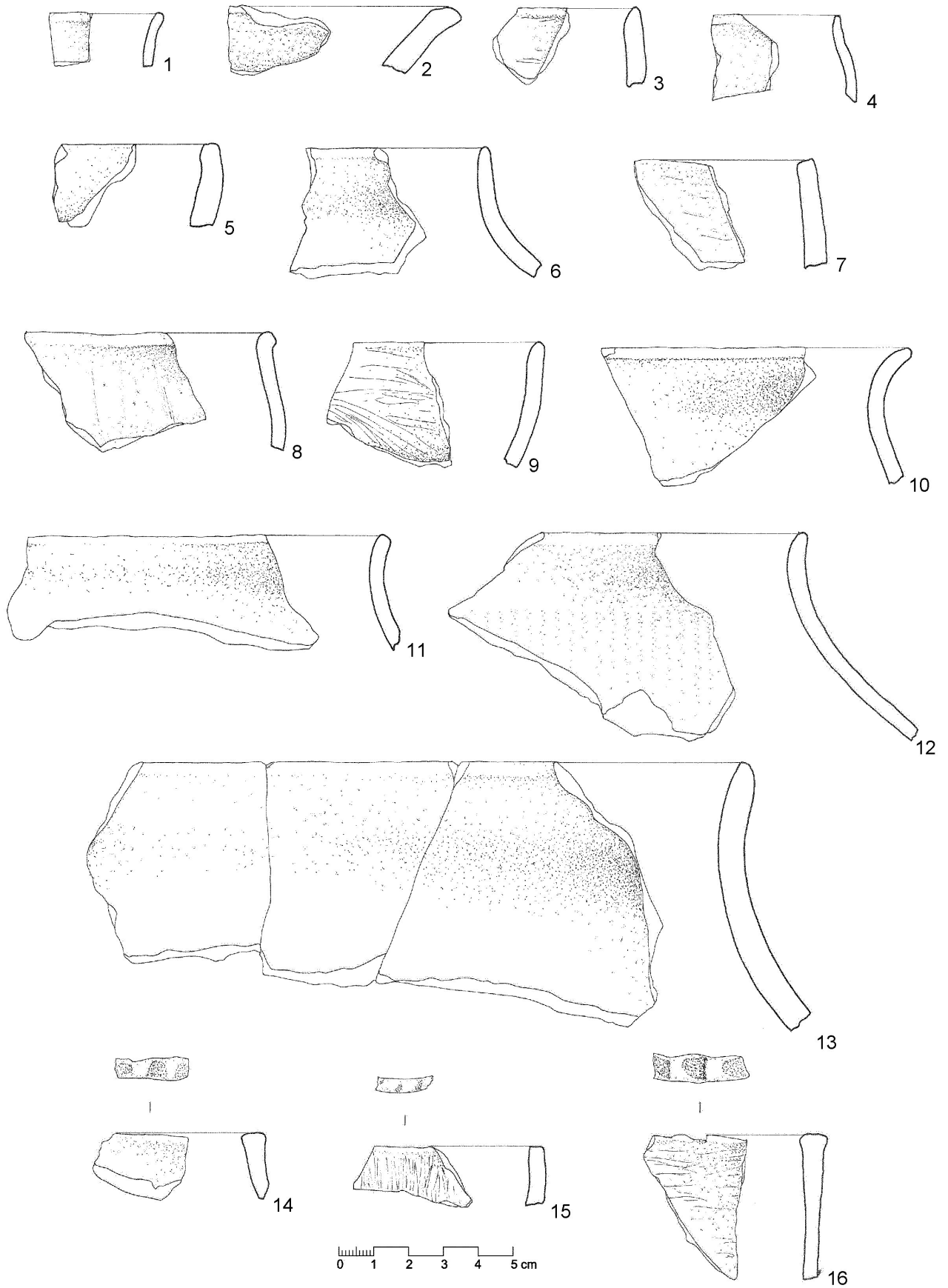

T. 5.

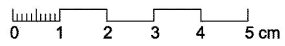
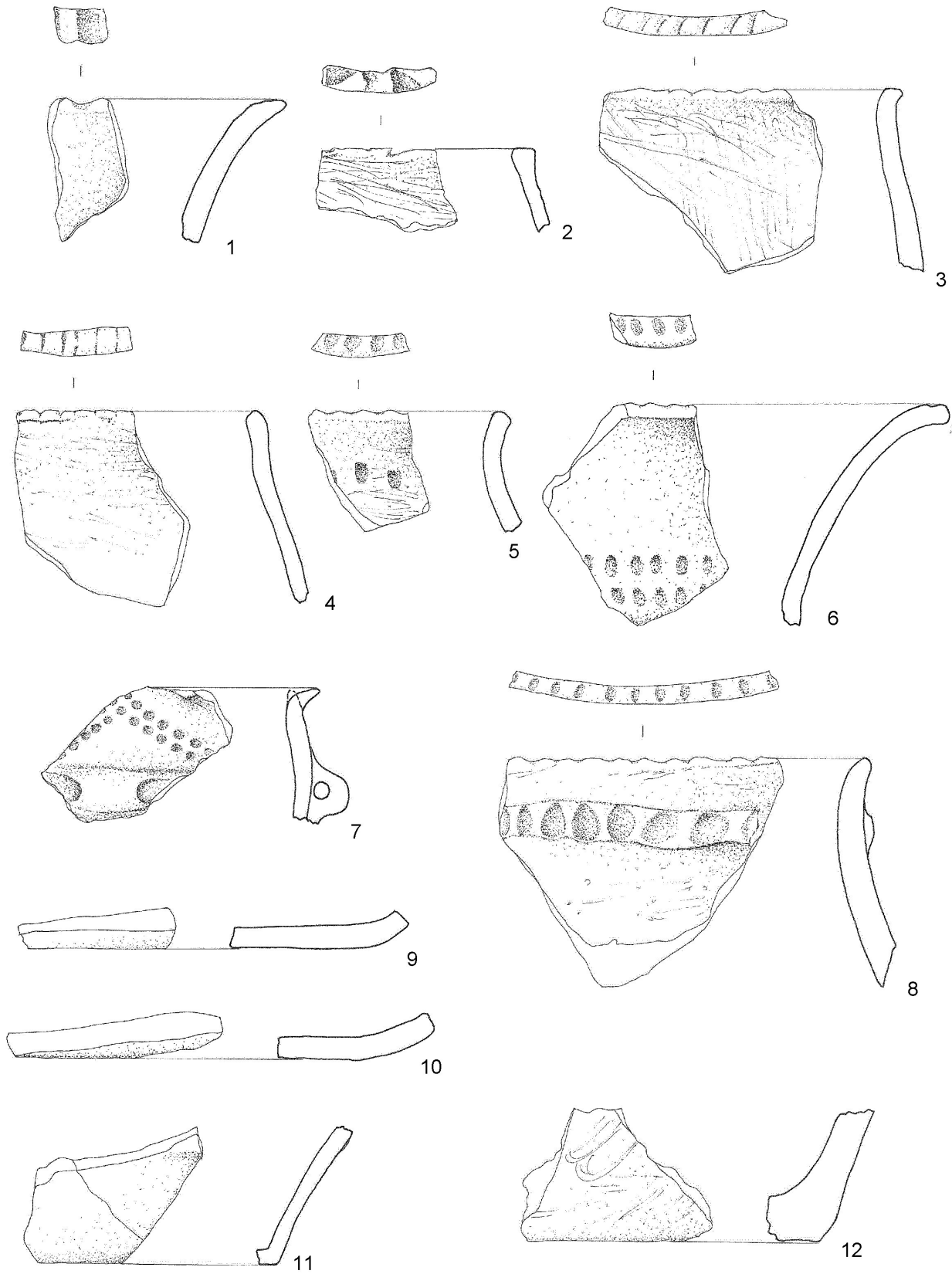

T. 6.

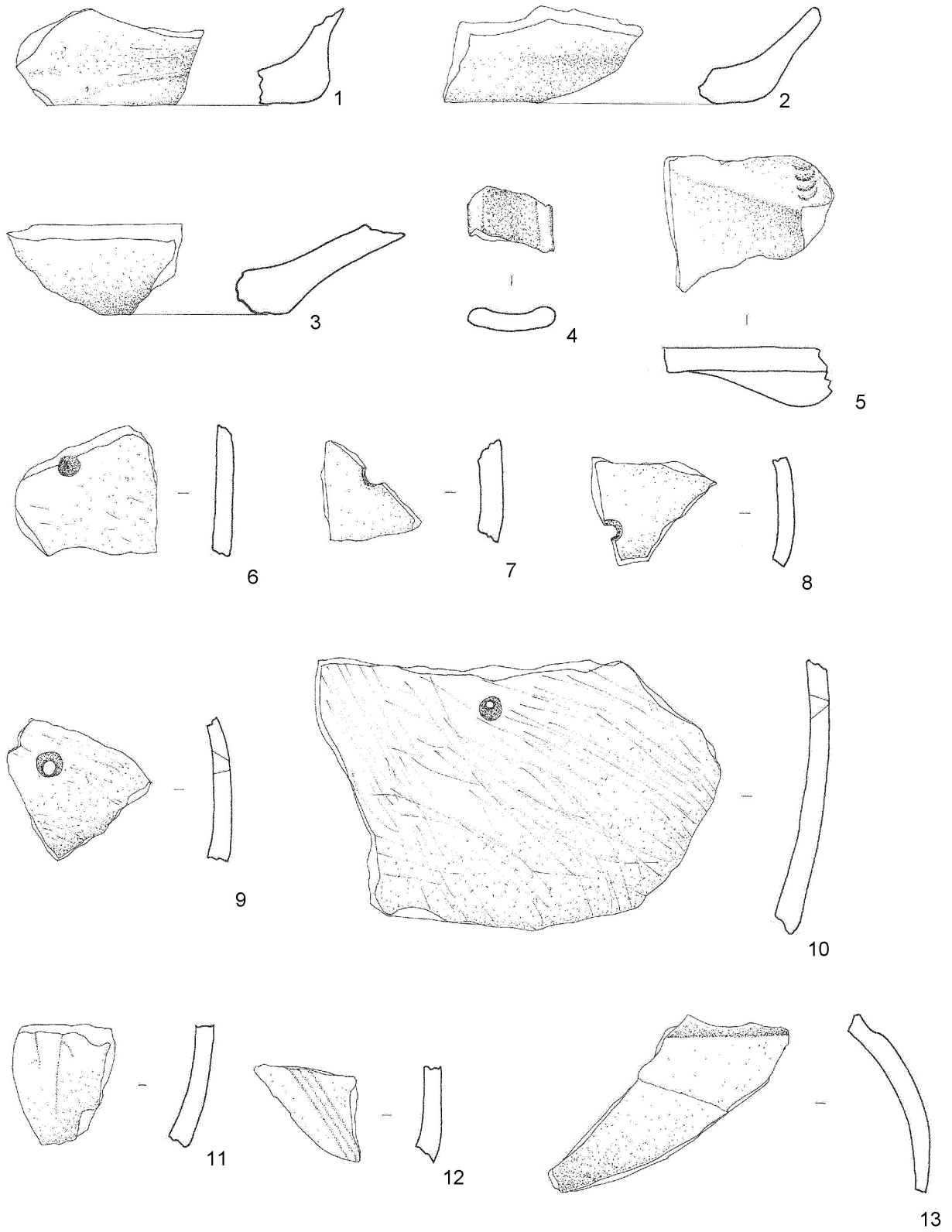

T. 7.

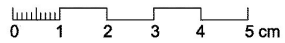
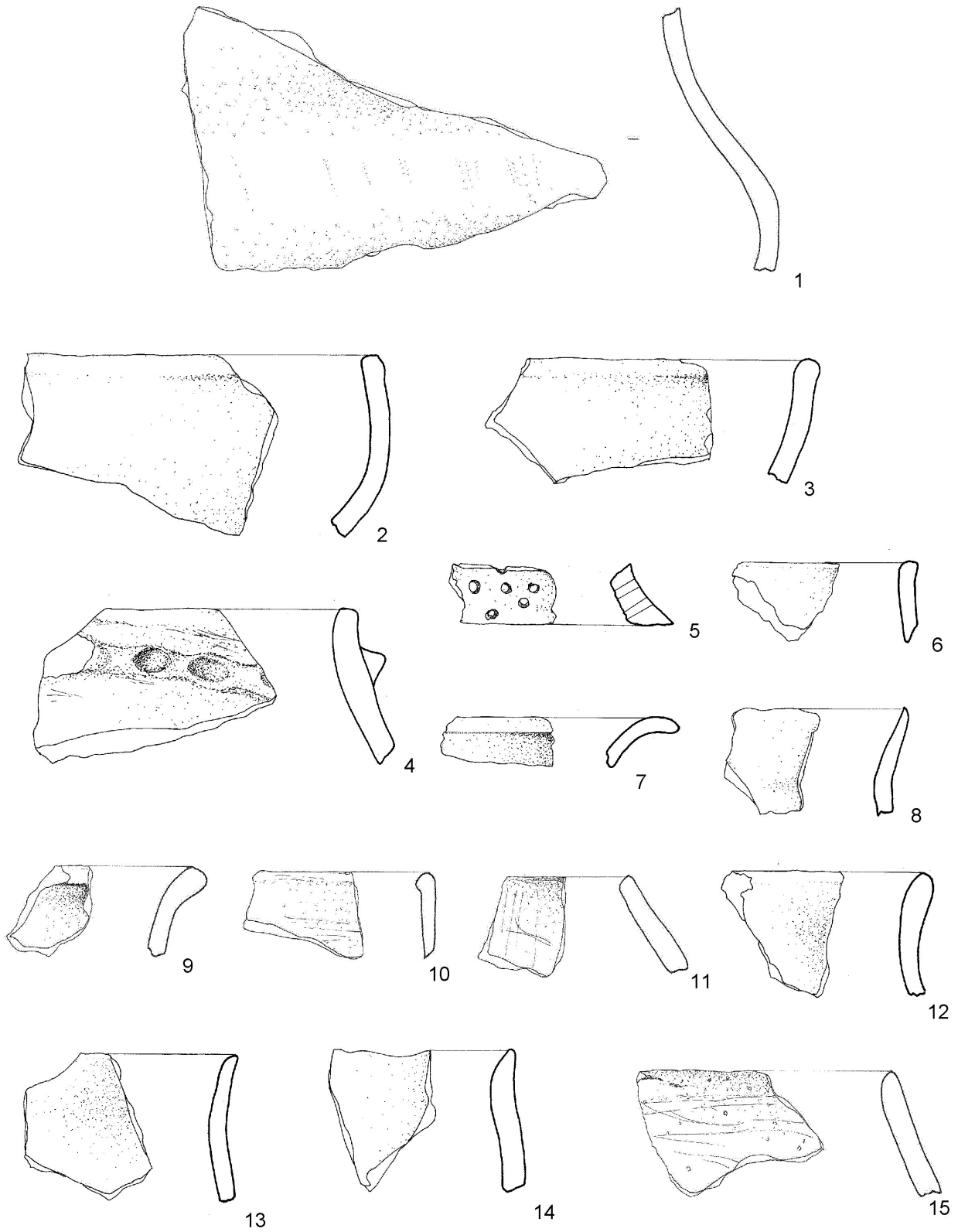

T. 8.

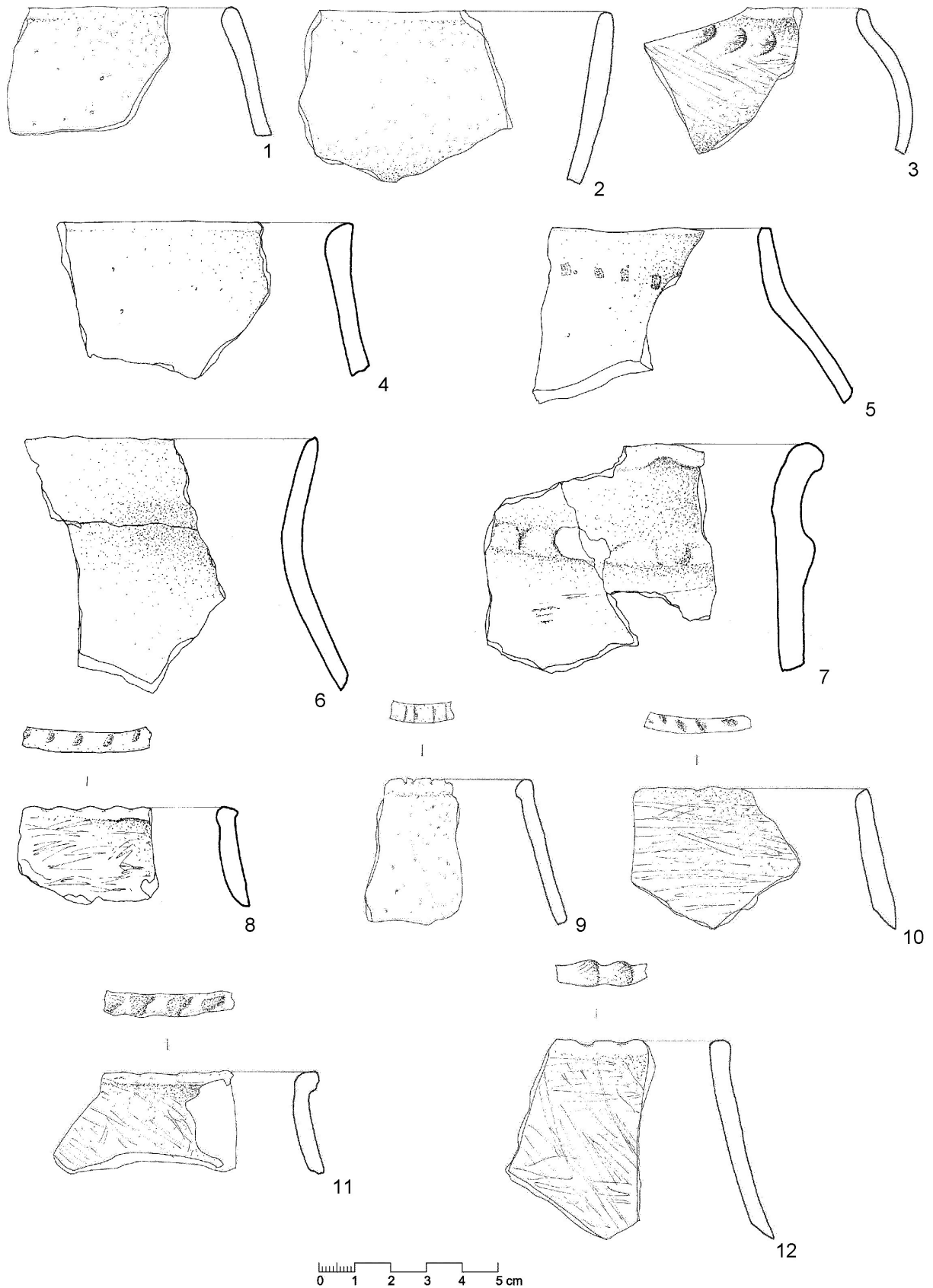

T. 9.

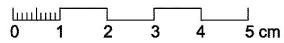
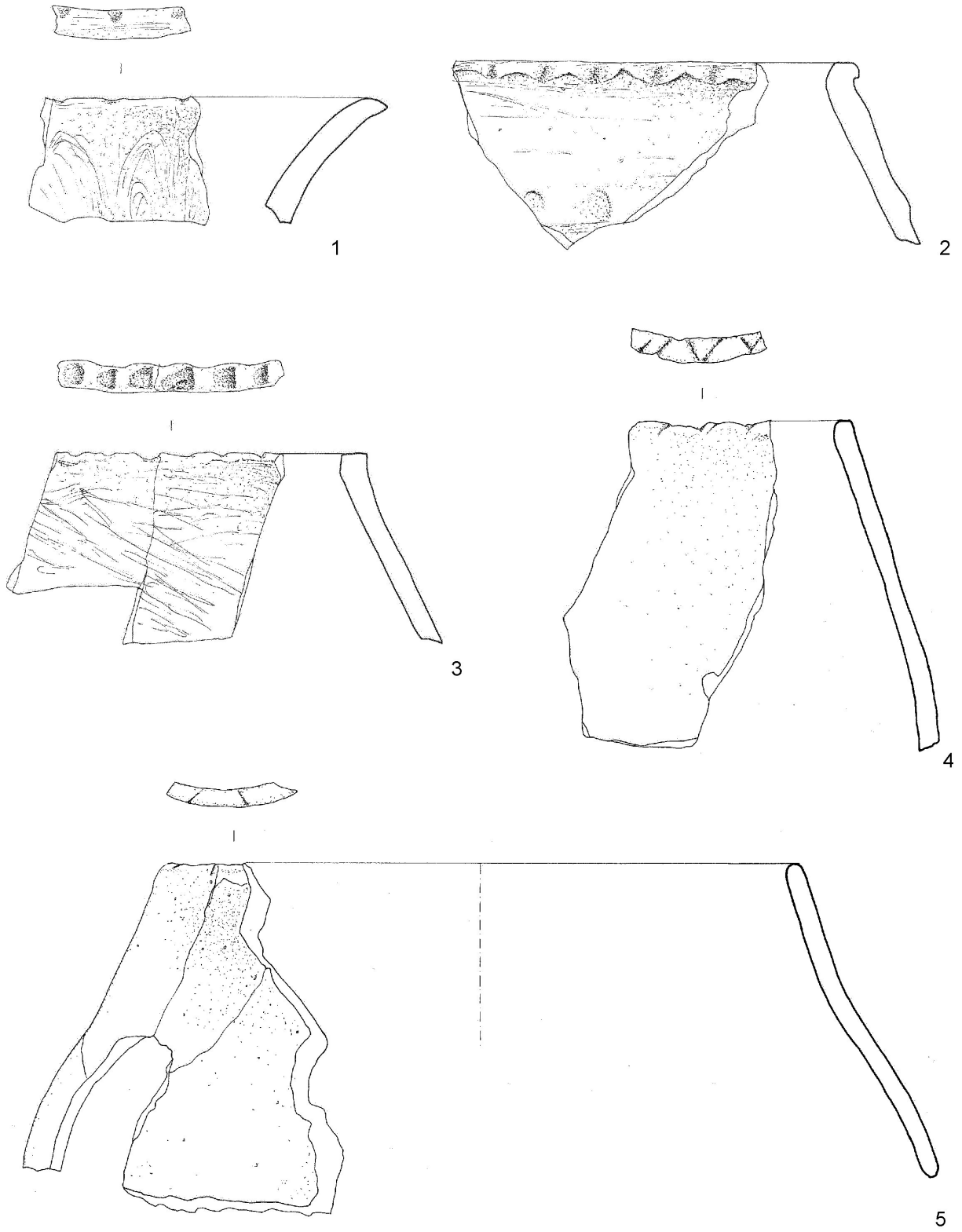

T. 10.

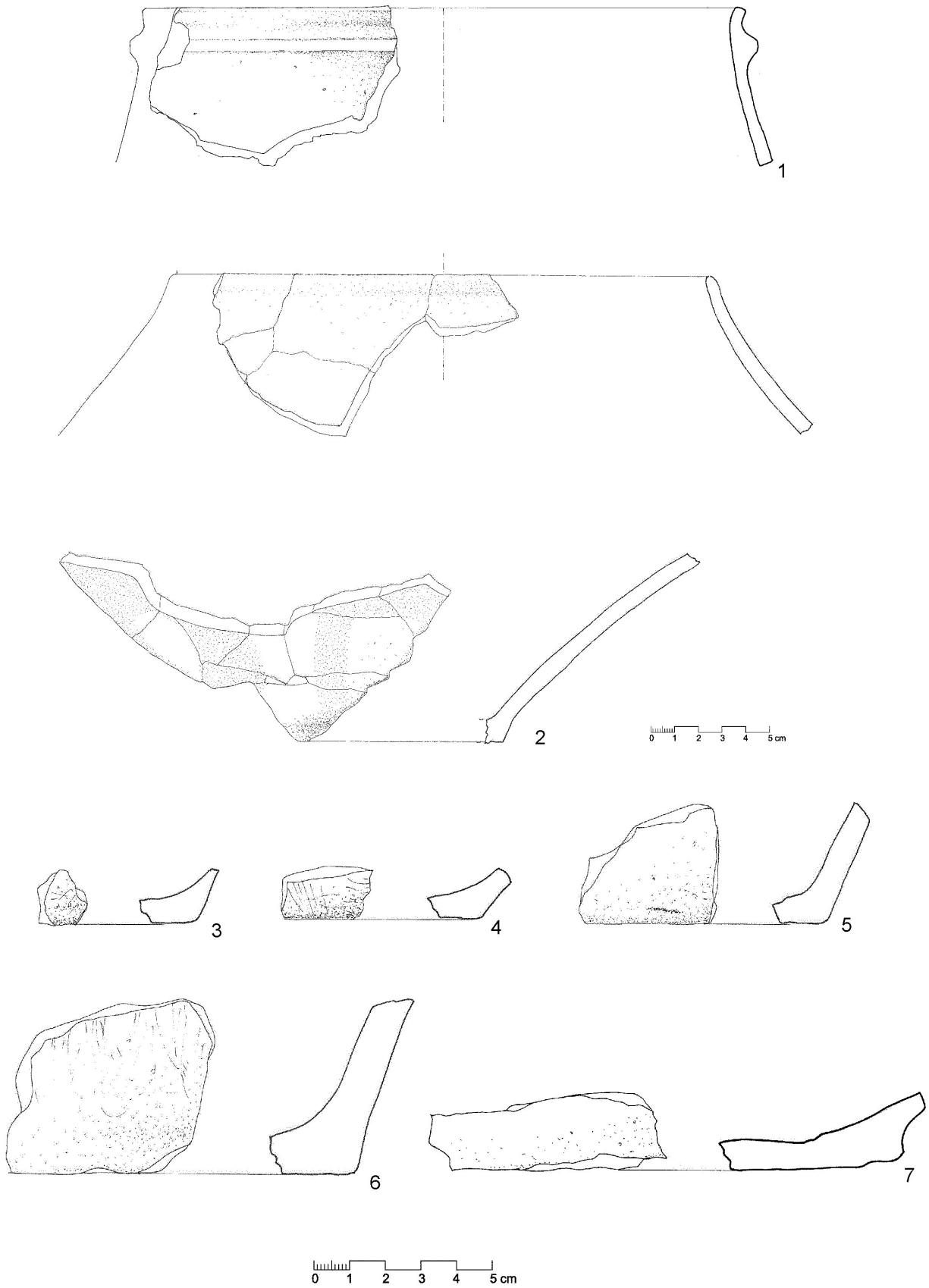

T. 11.



T. 12.

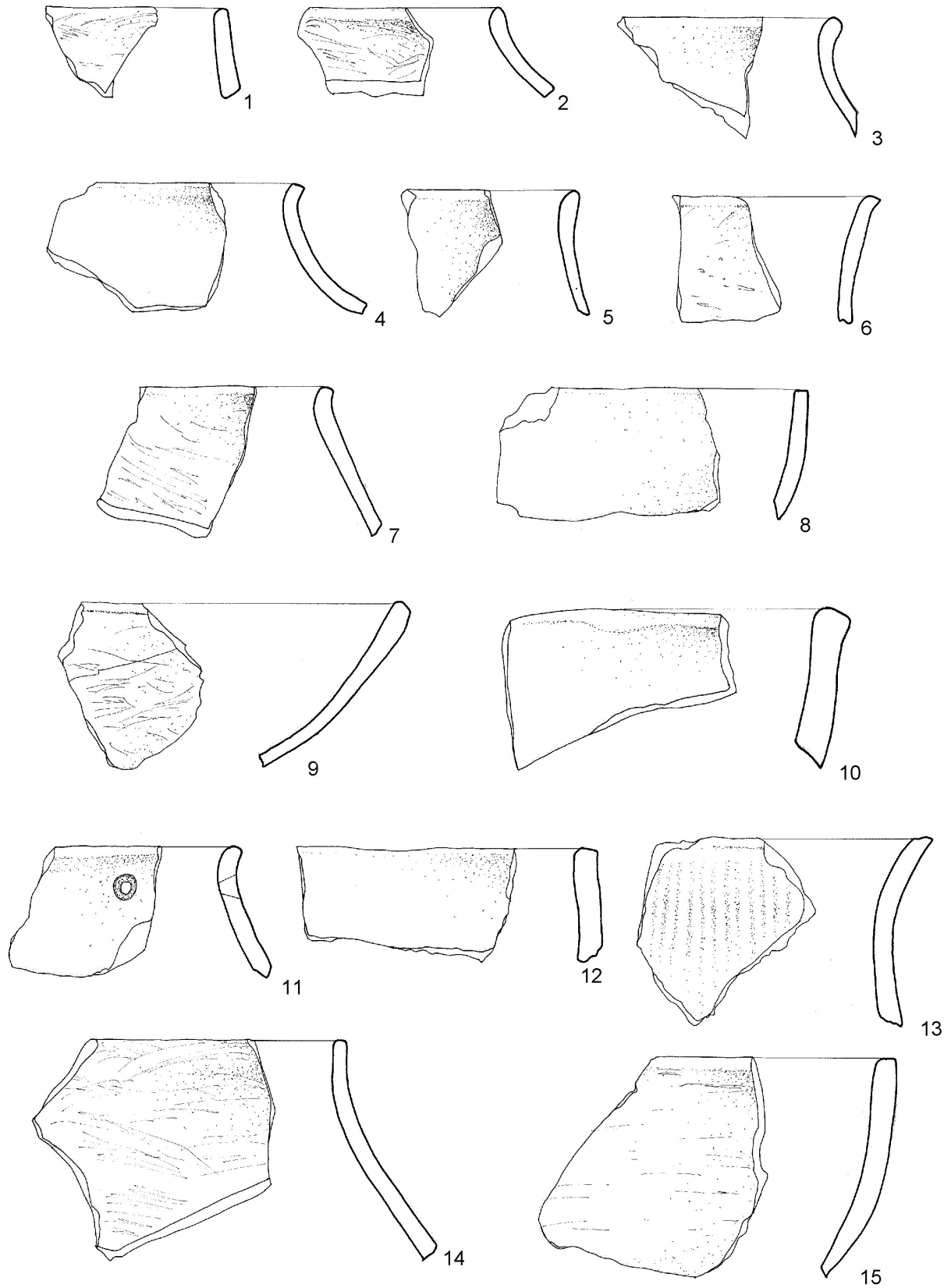

T. 13.

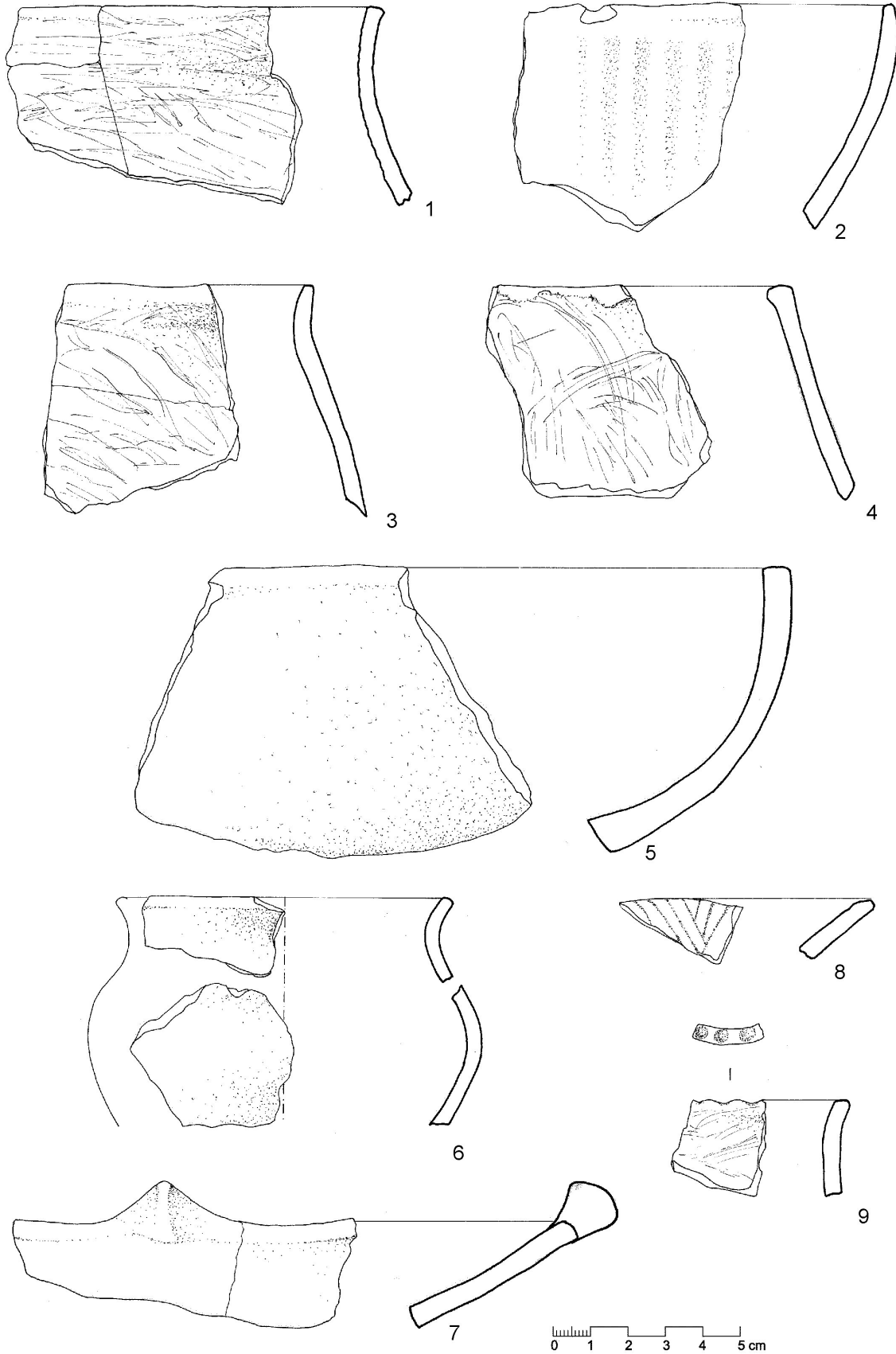

T. 14.

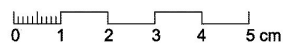
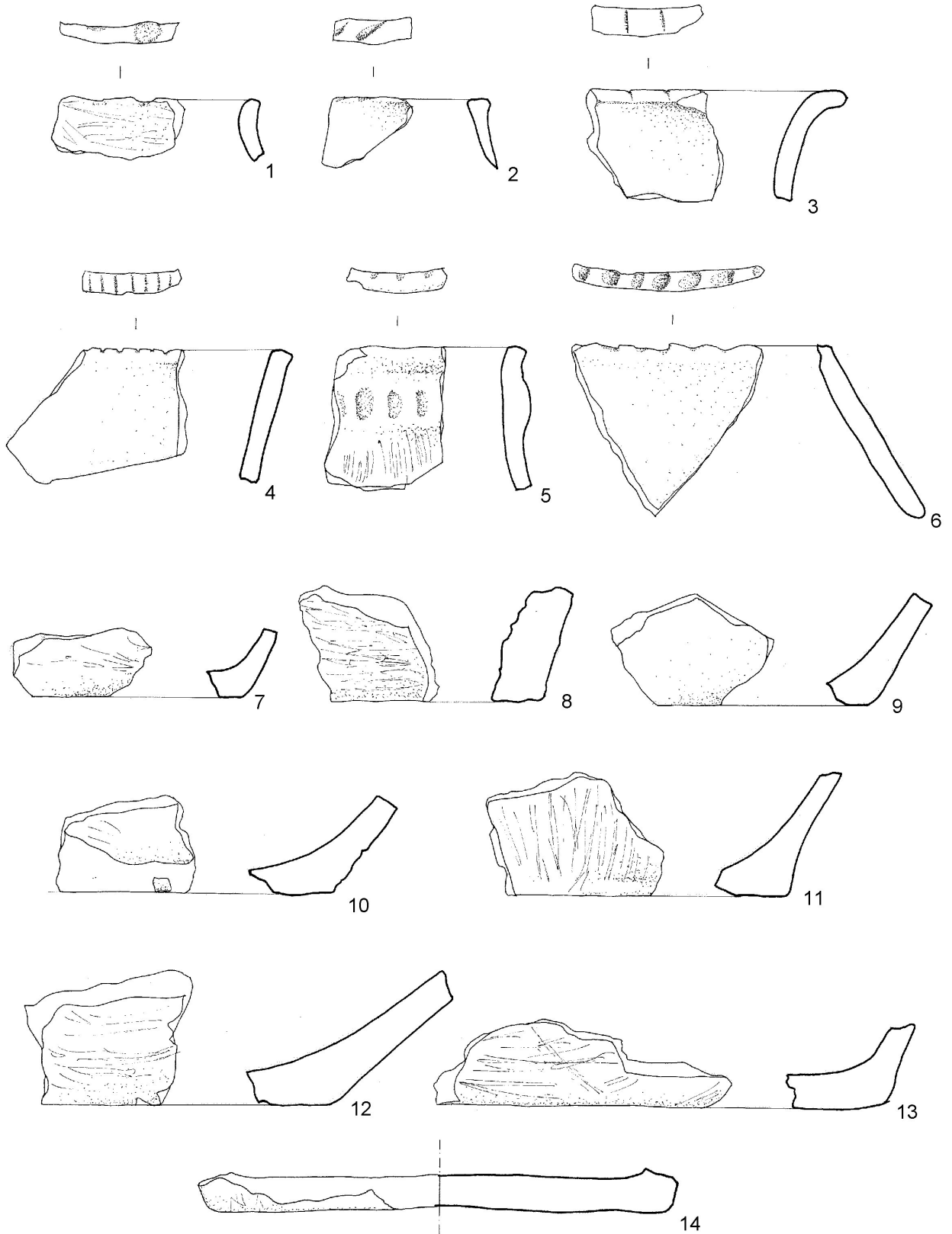

T. 15.

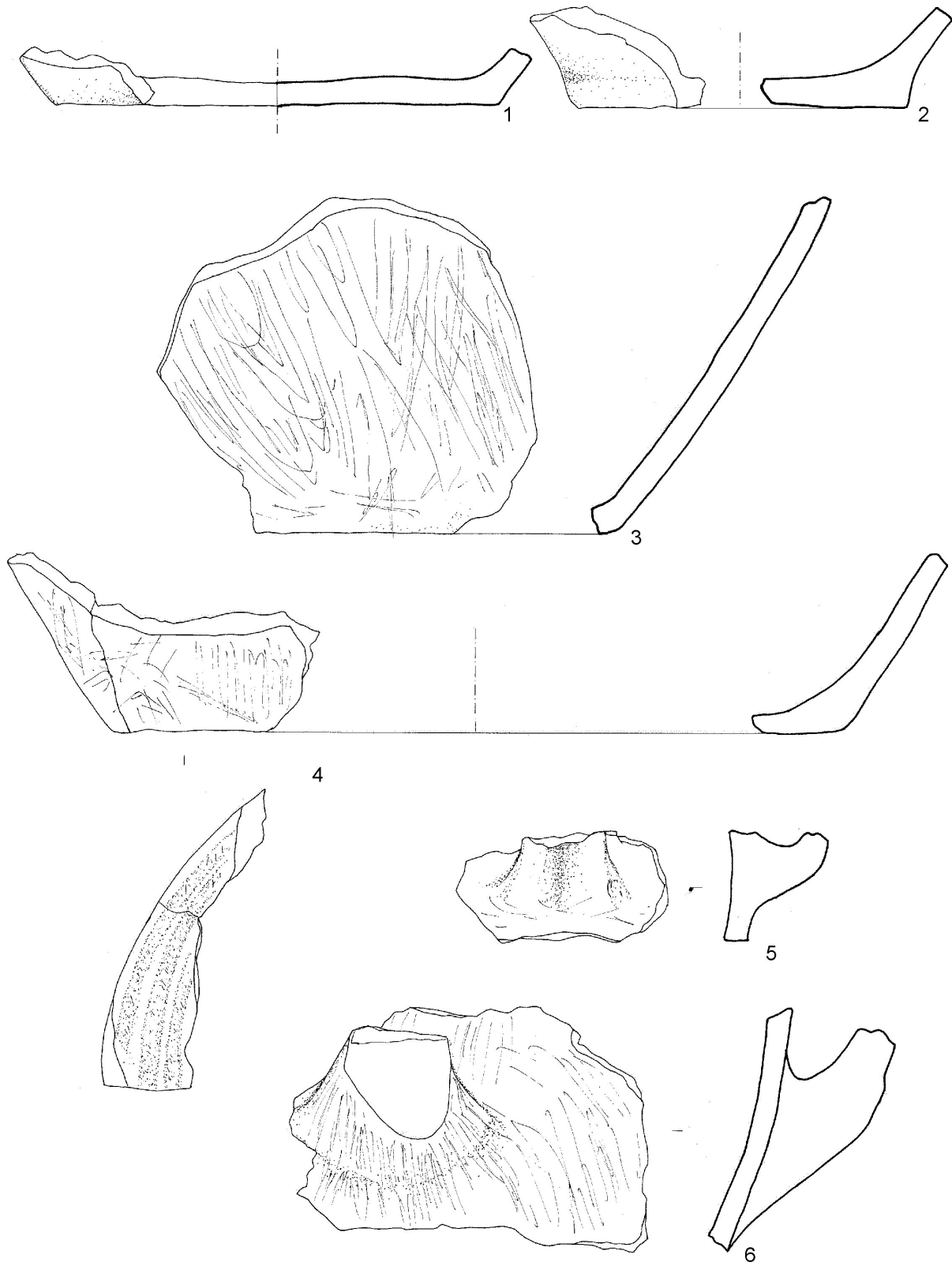

0 1 2 3 4 5 cm

T. 16.

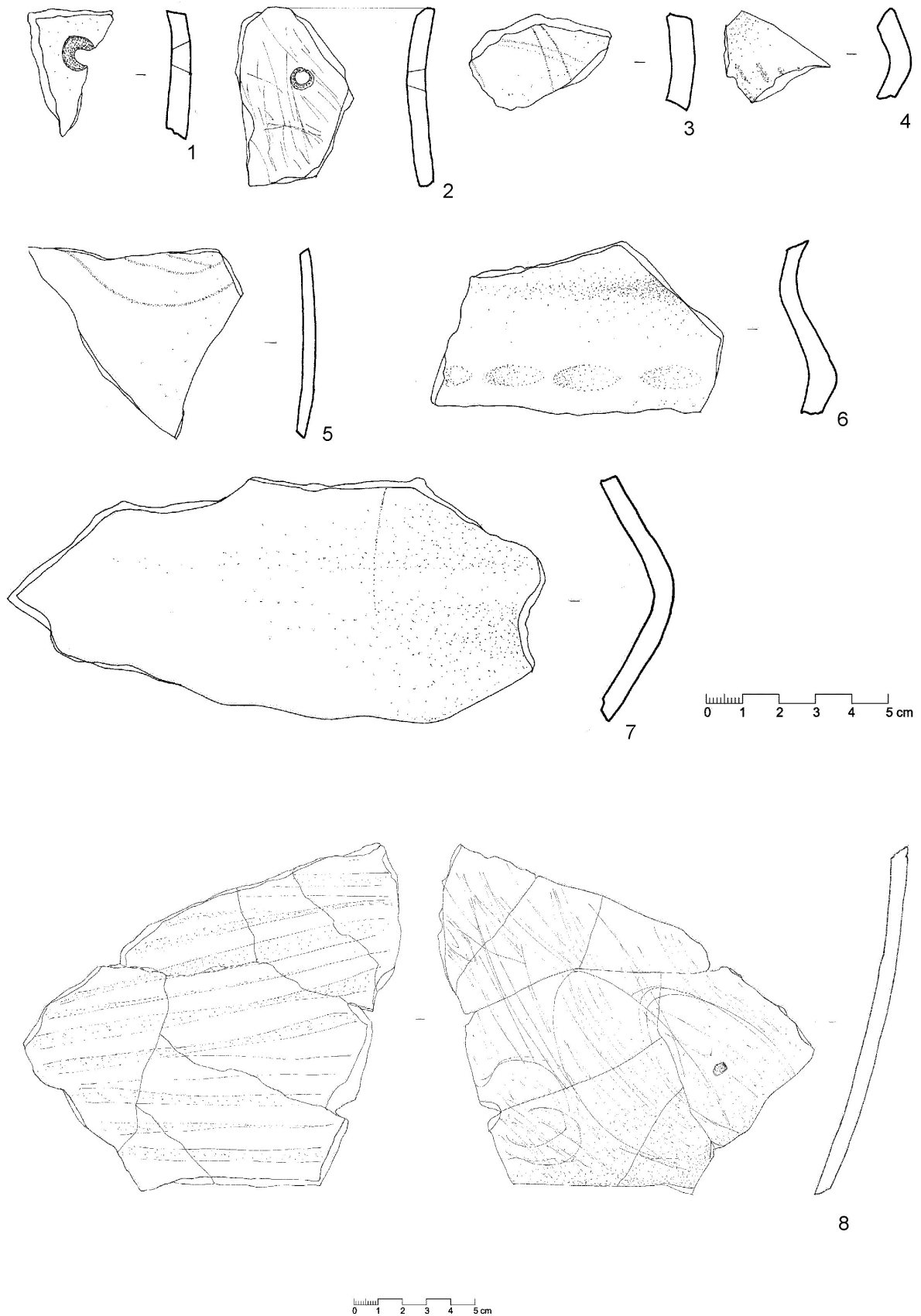

T. 17.

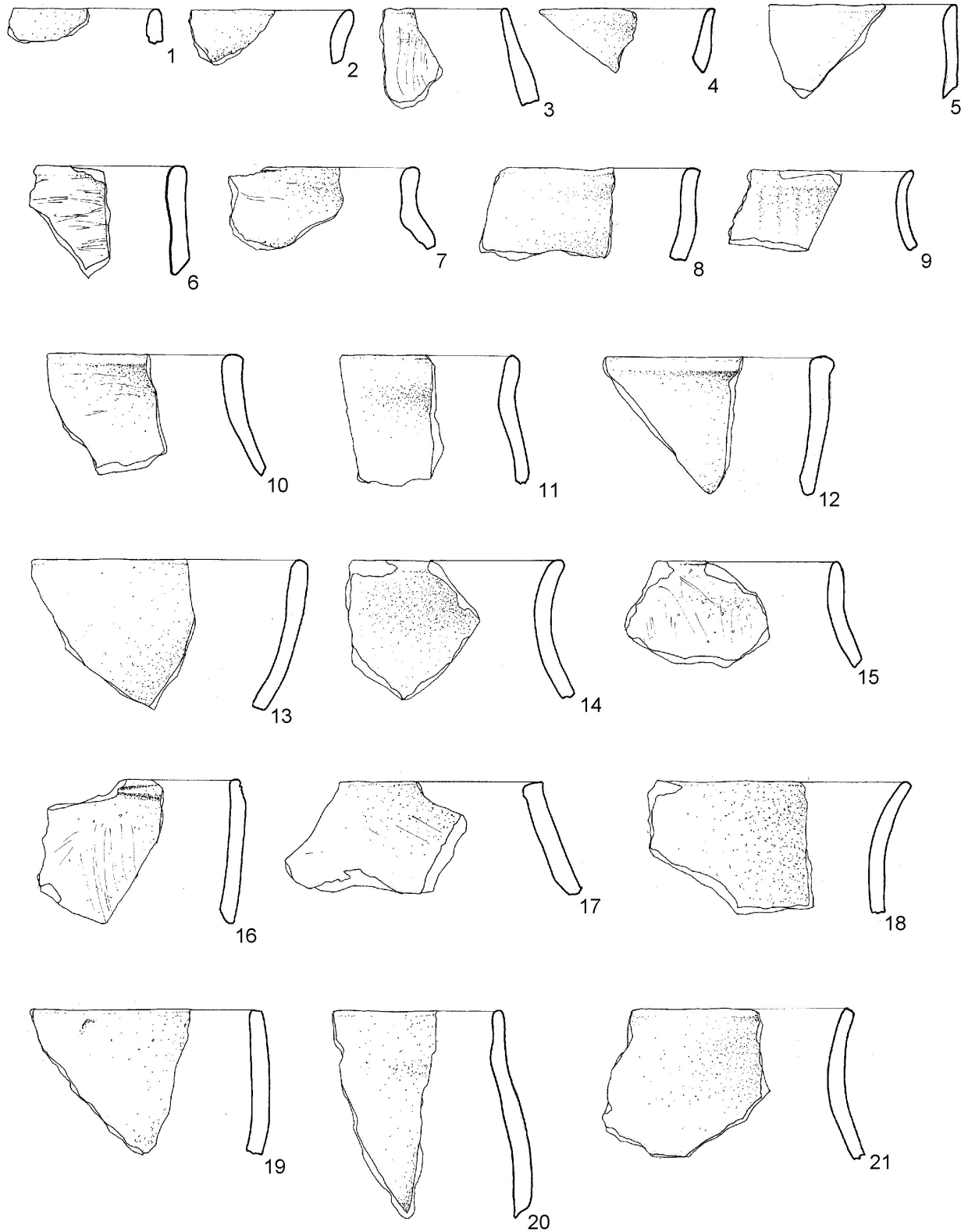

0 1 2 3 4 5 cm

T. 18.

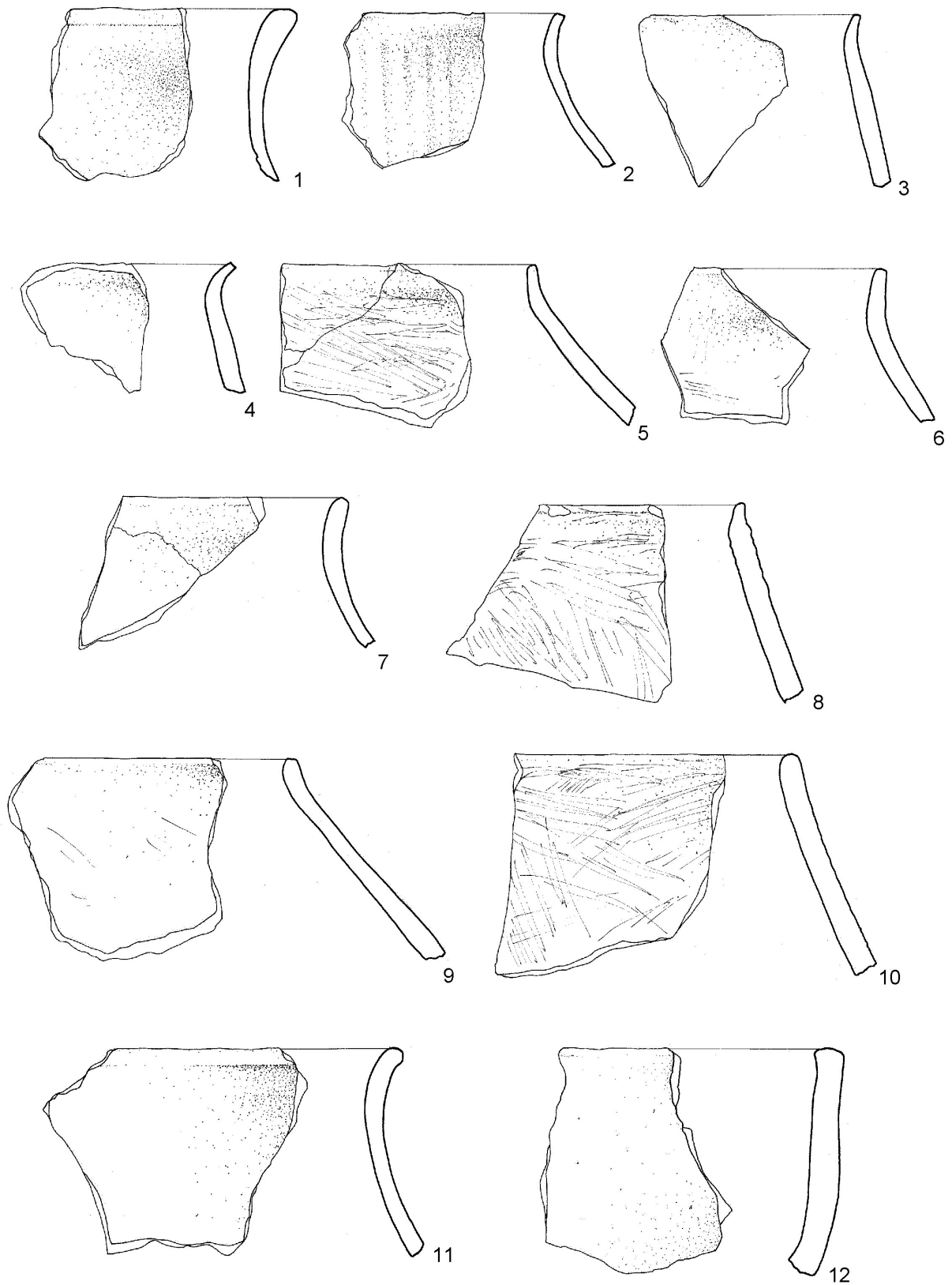

T. 19.

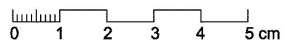
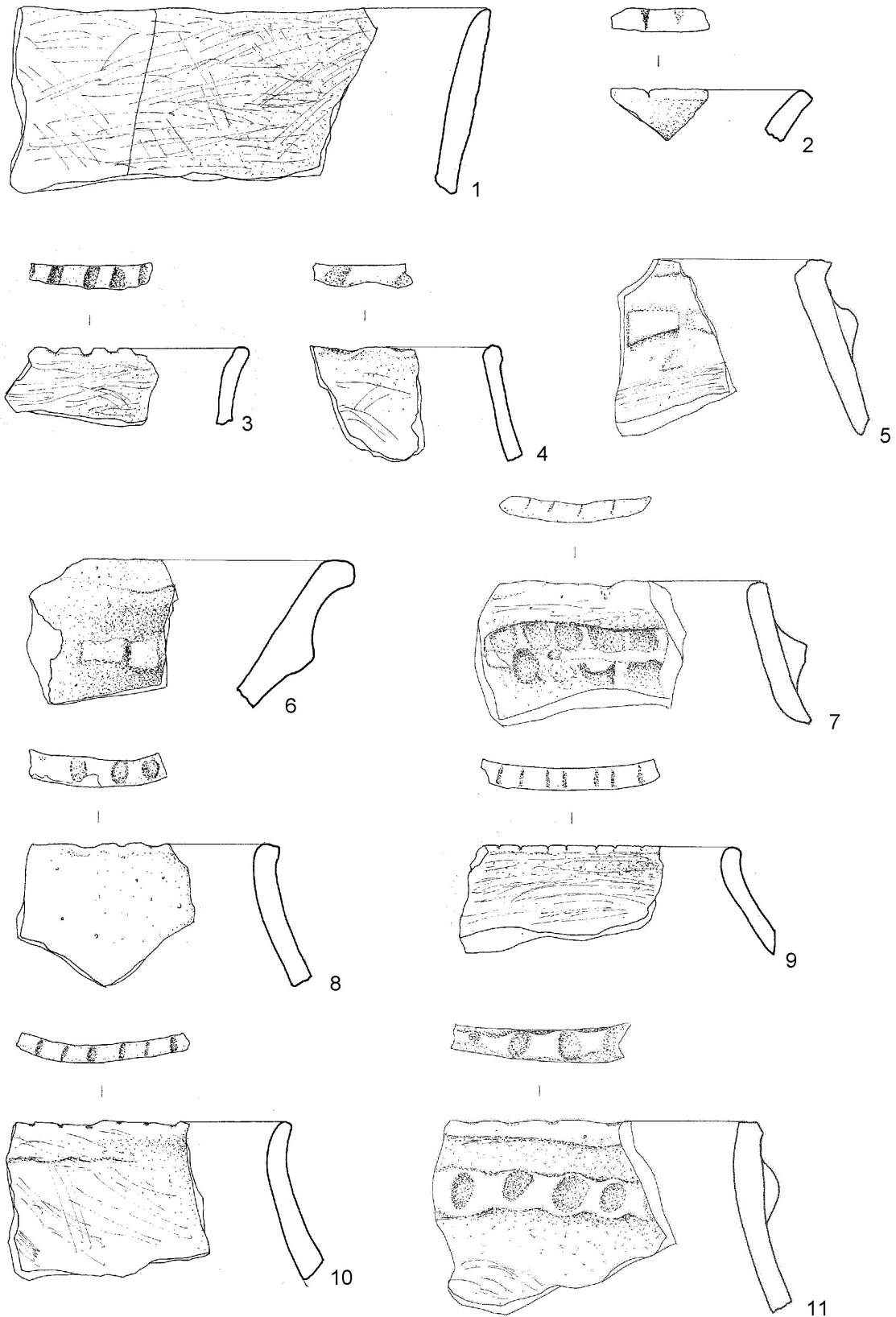

T. 20.

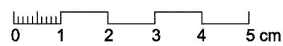
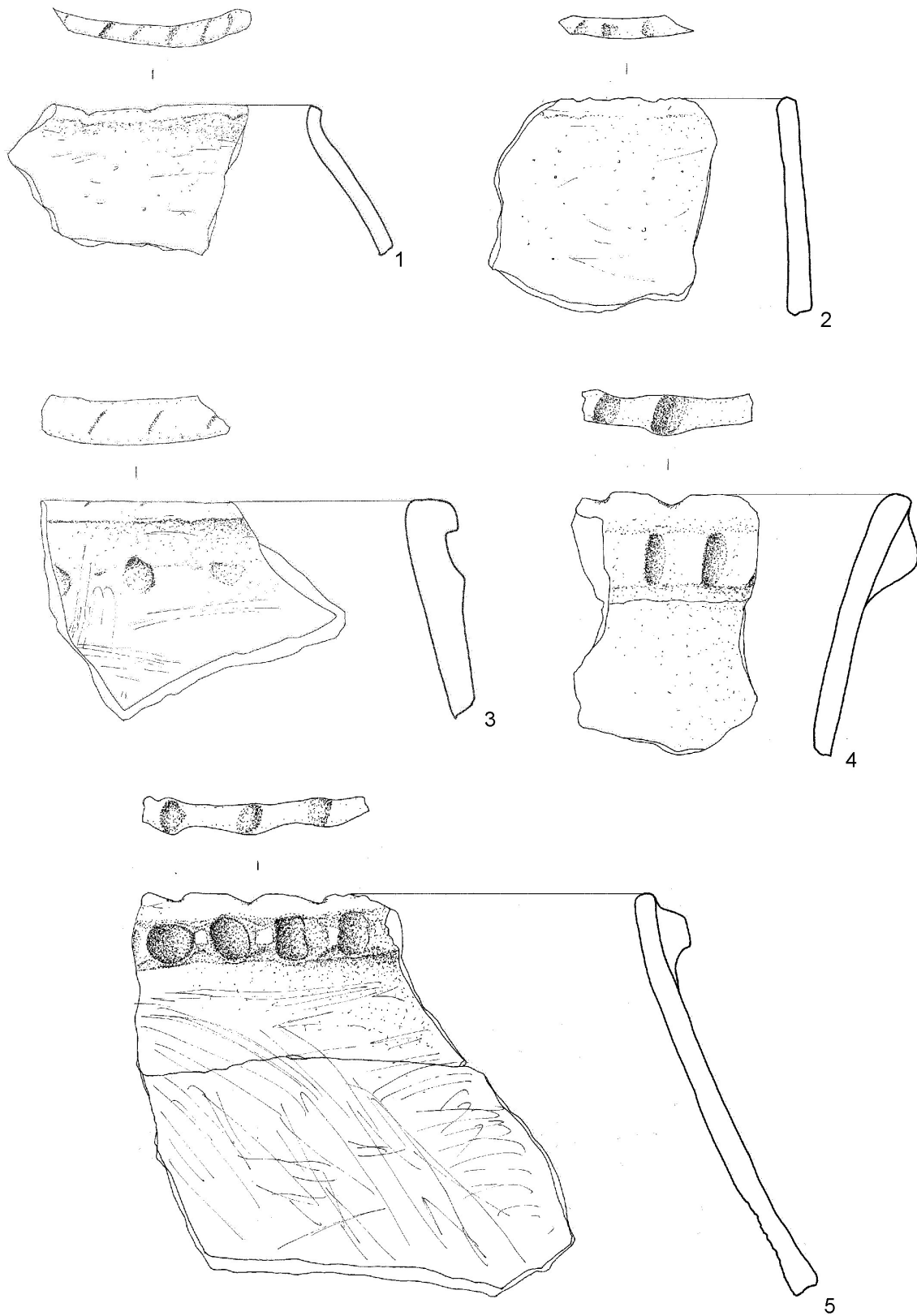

T. 21.

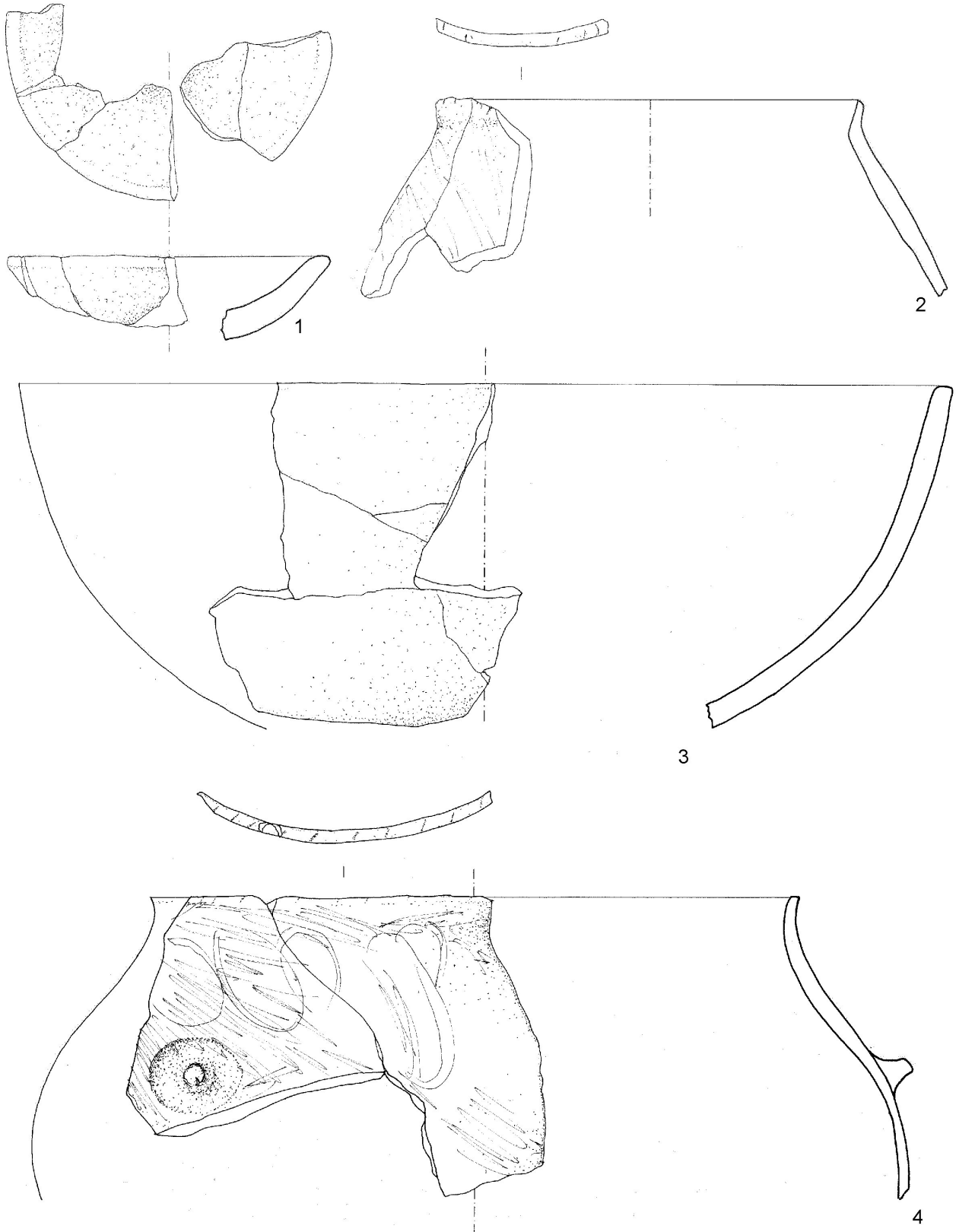

T. 22.

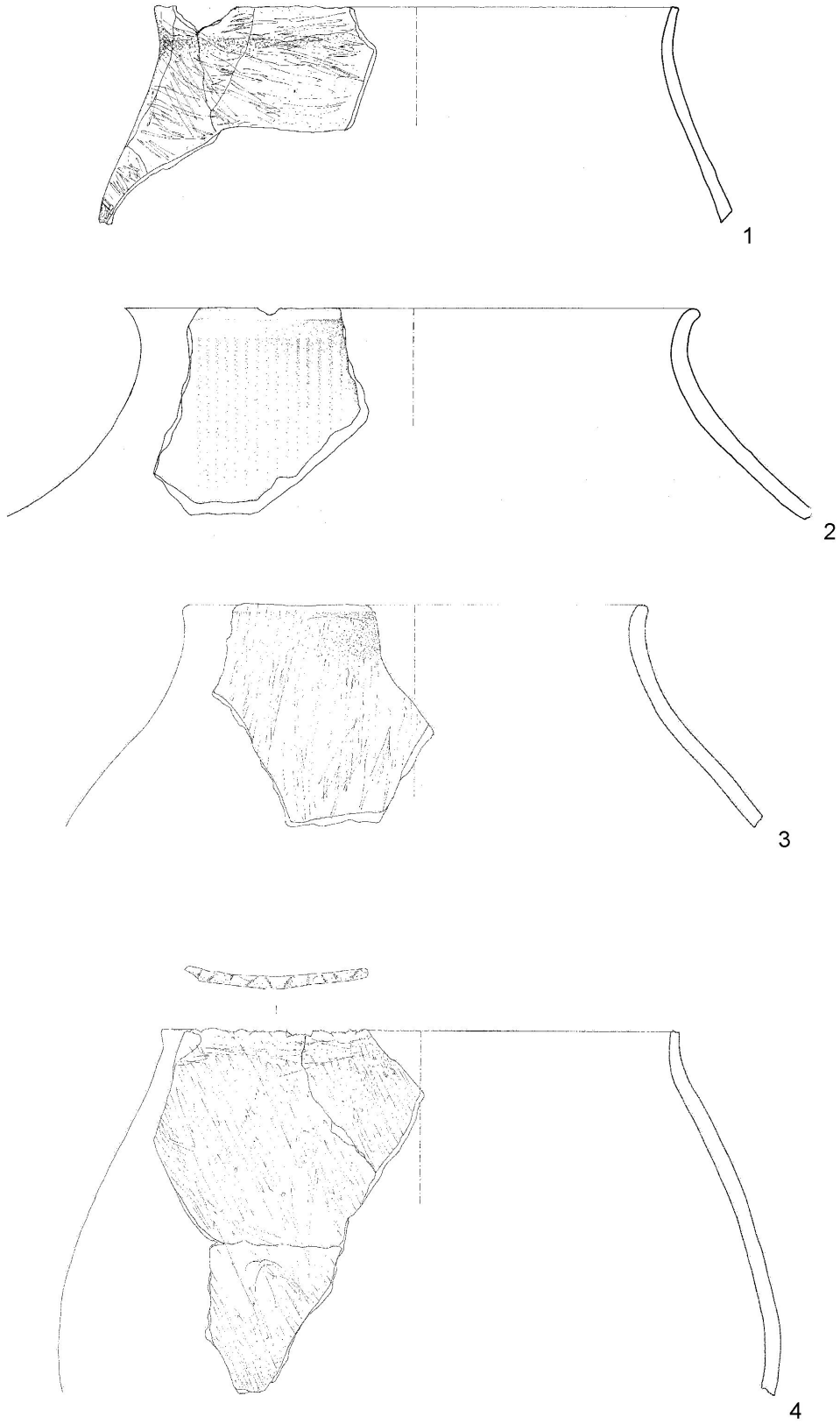

0 1 2 3 4 5 cm

T. 23.

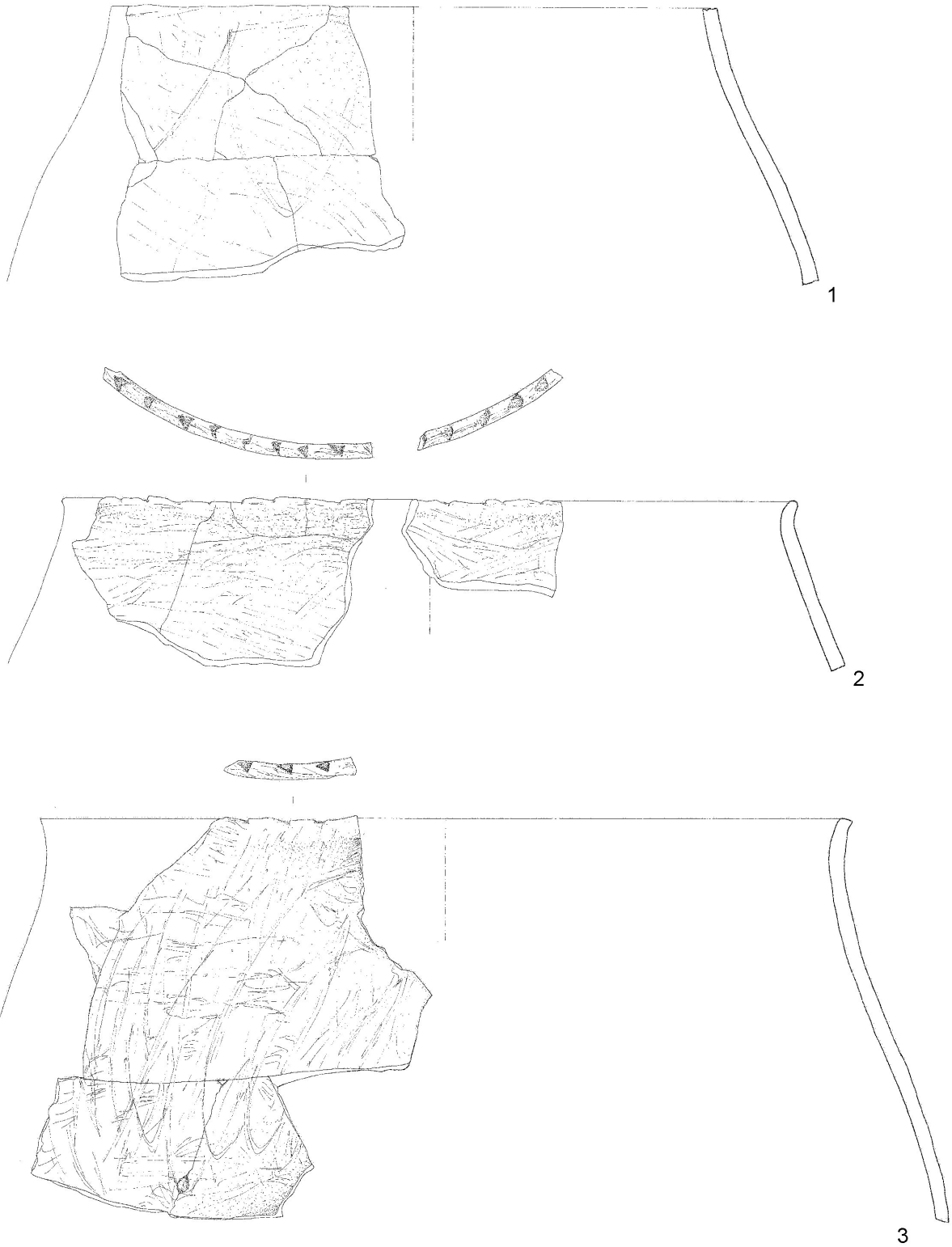

T. 24.

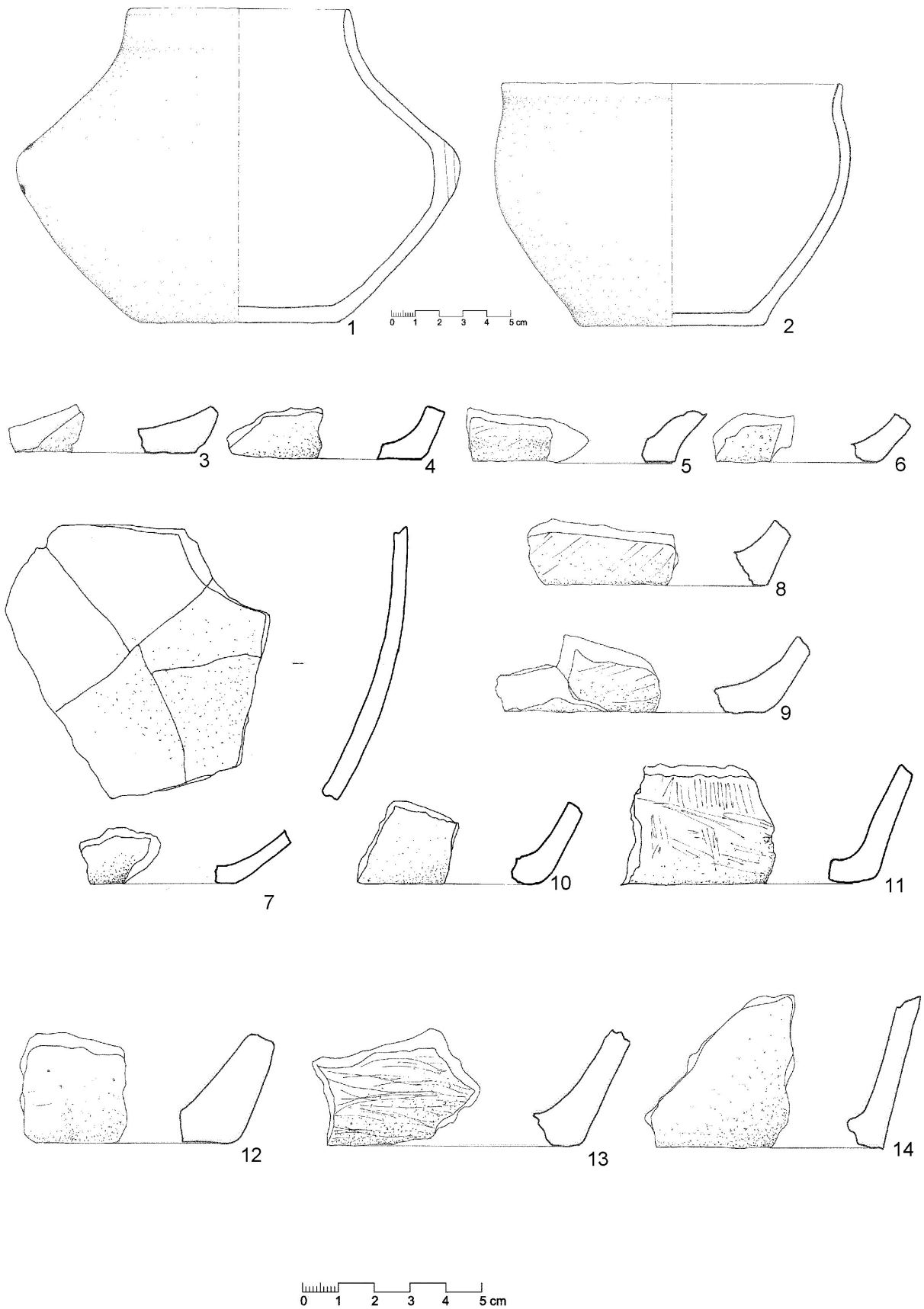

T. 25.

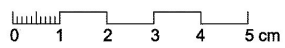
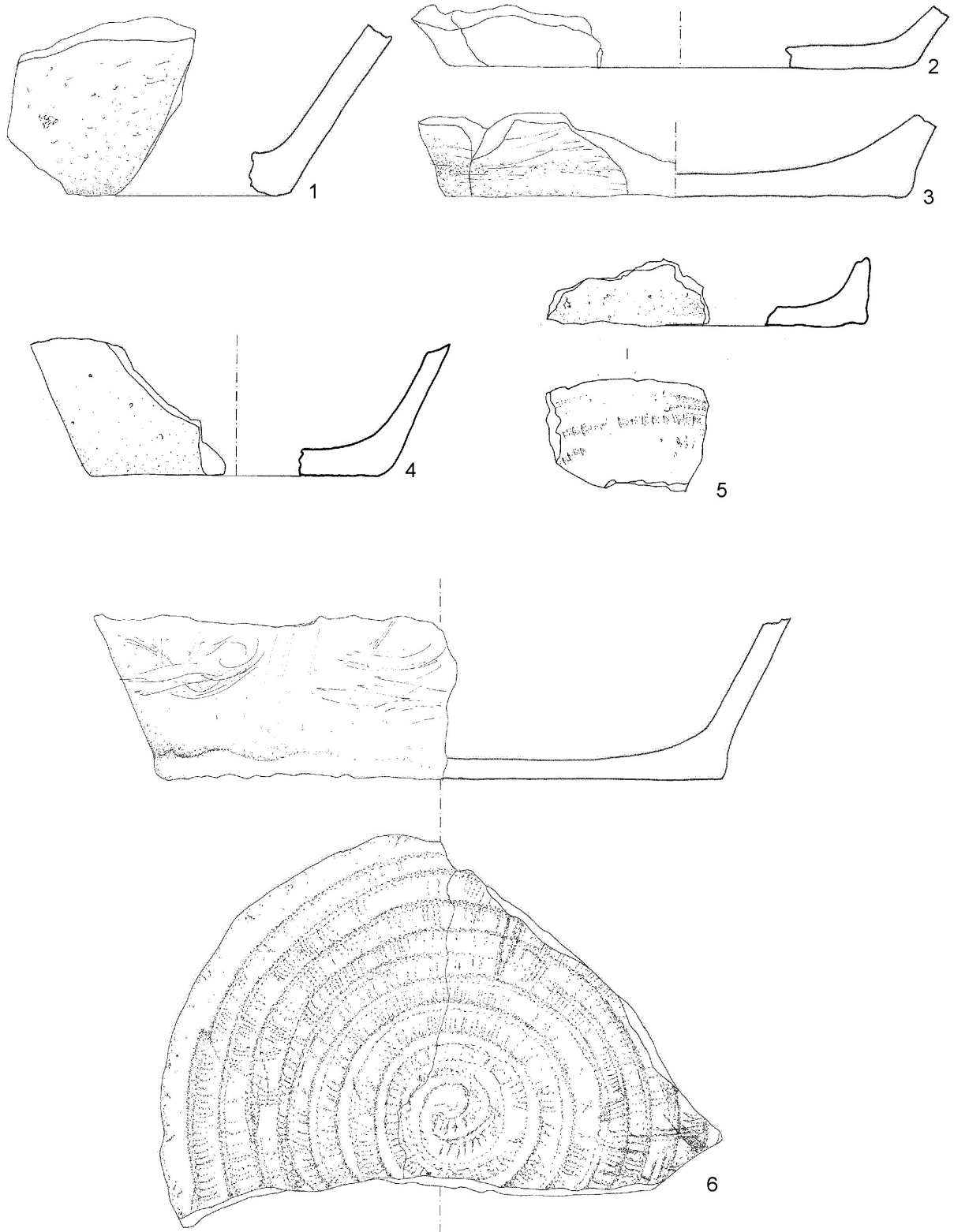

T. 26.

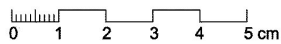
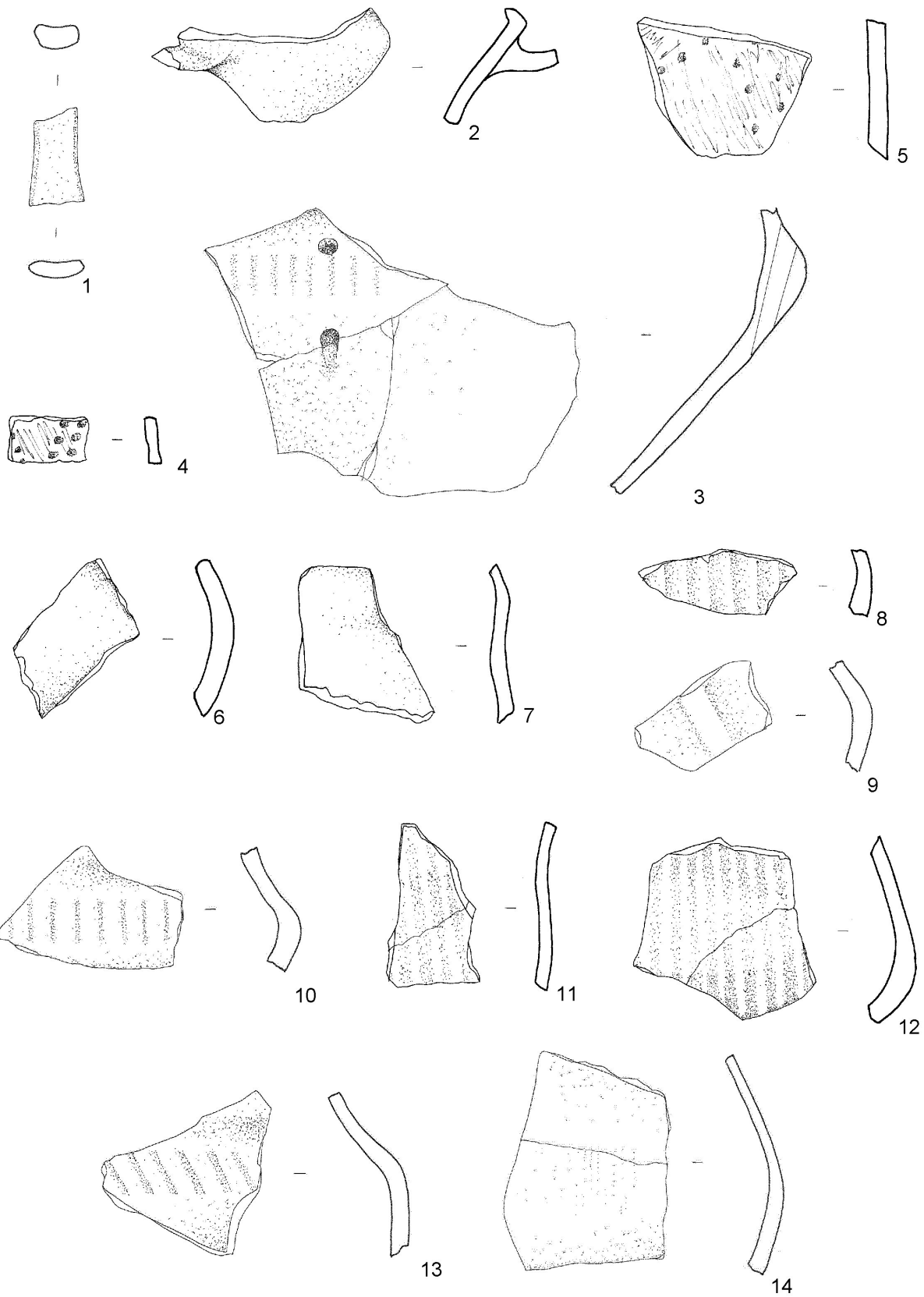

T. 27.

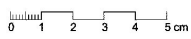
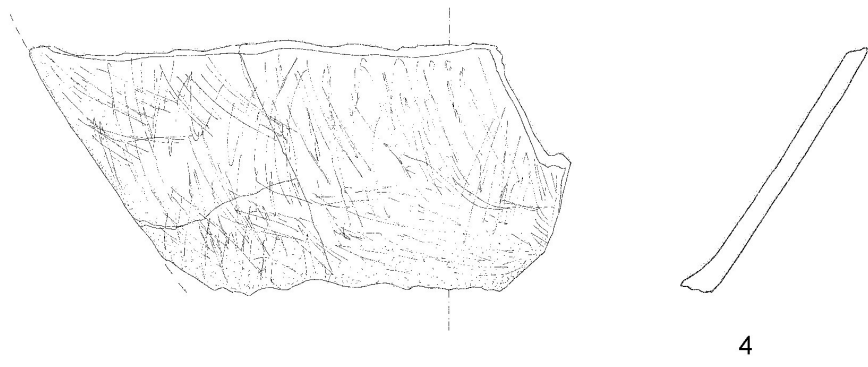
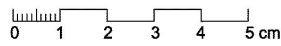
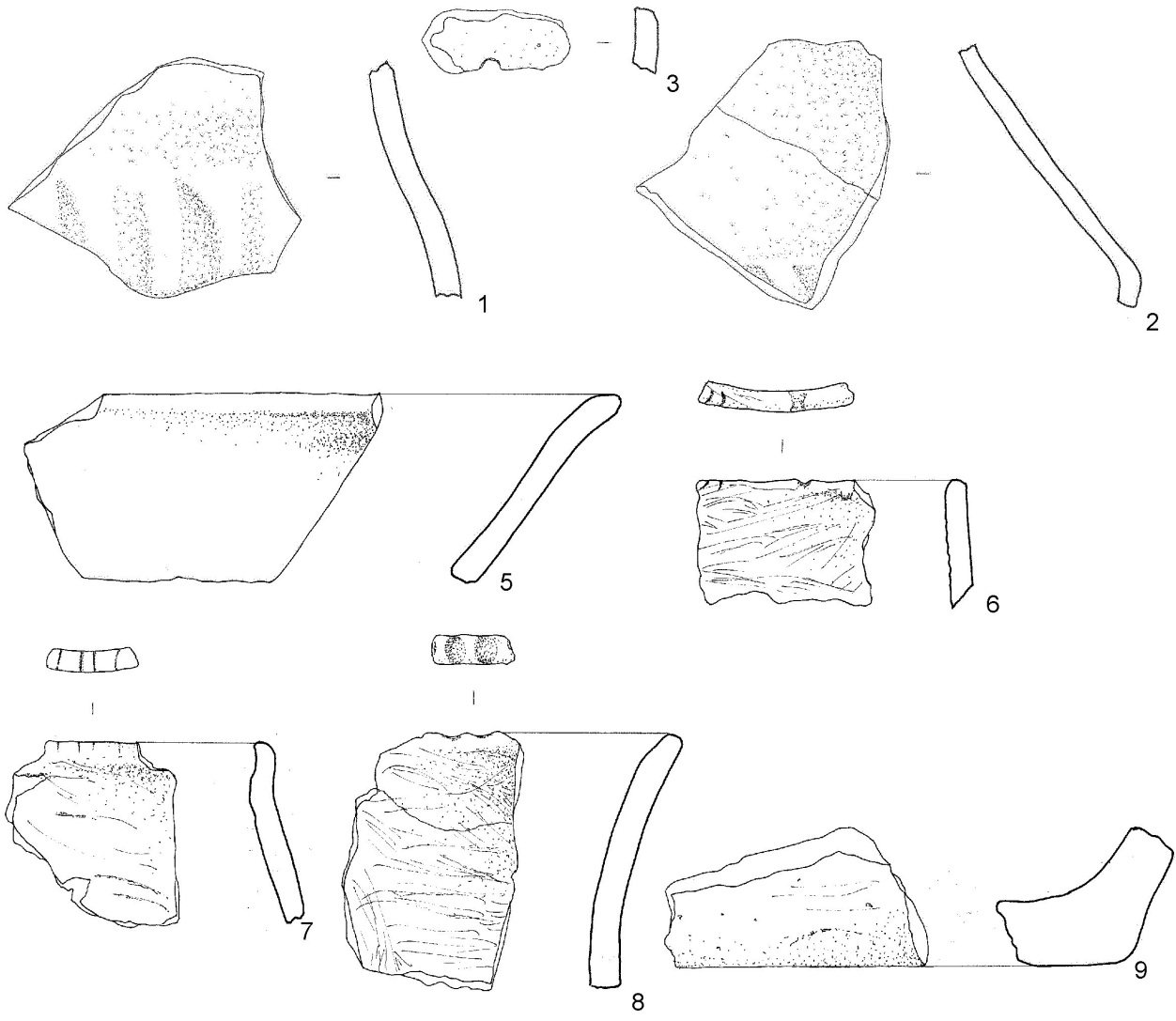

T. 28.

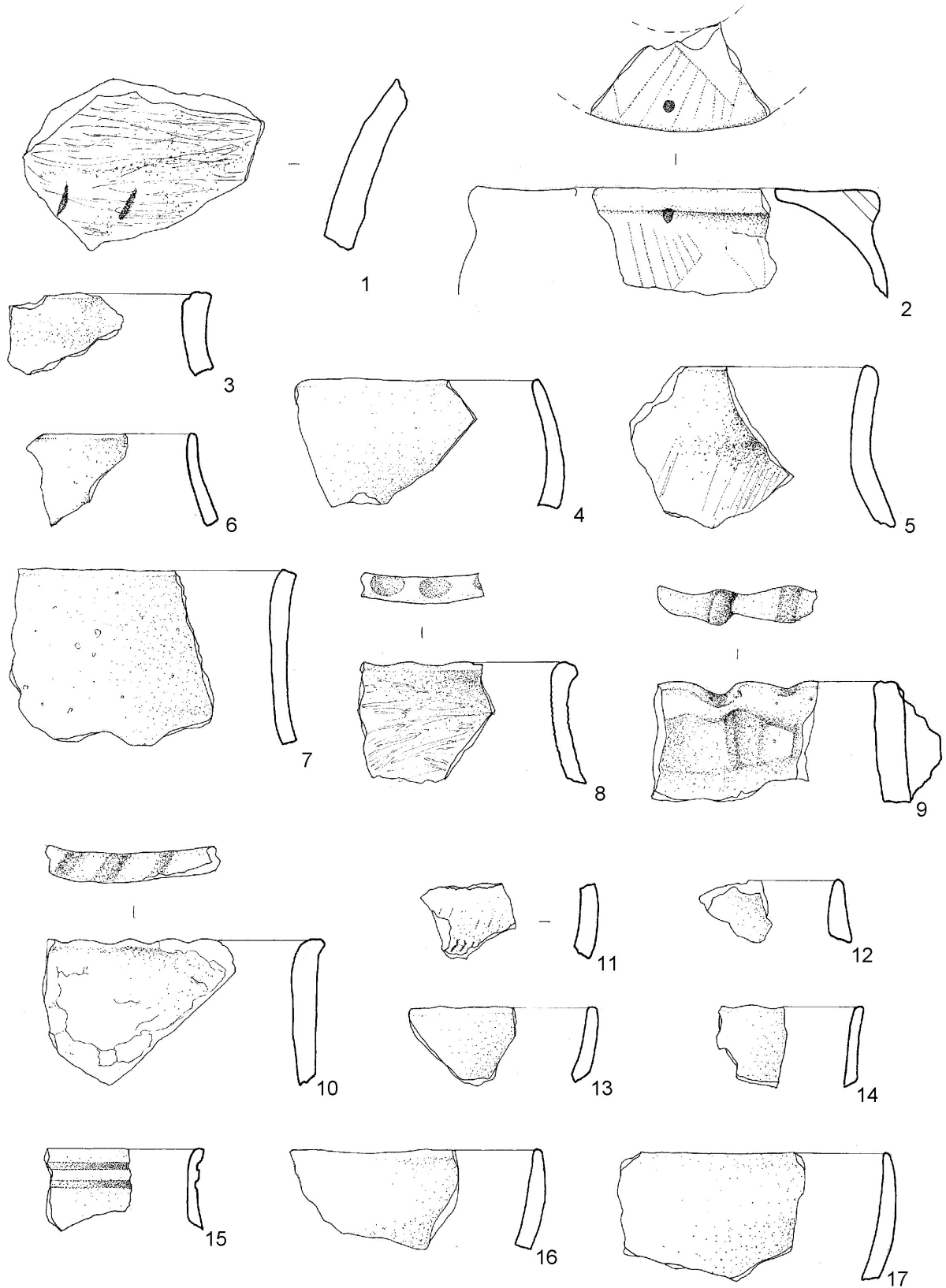

T. 29.

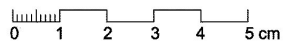
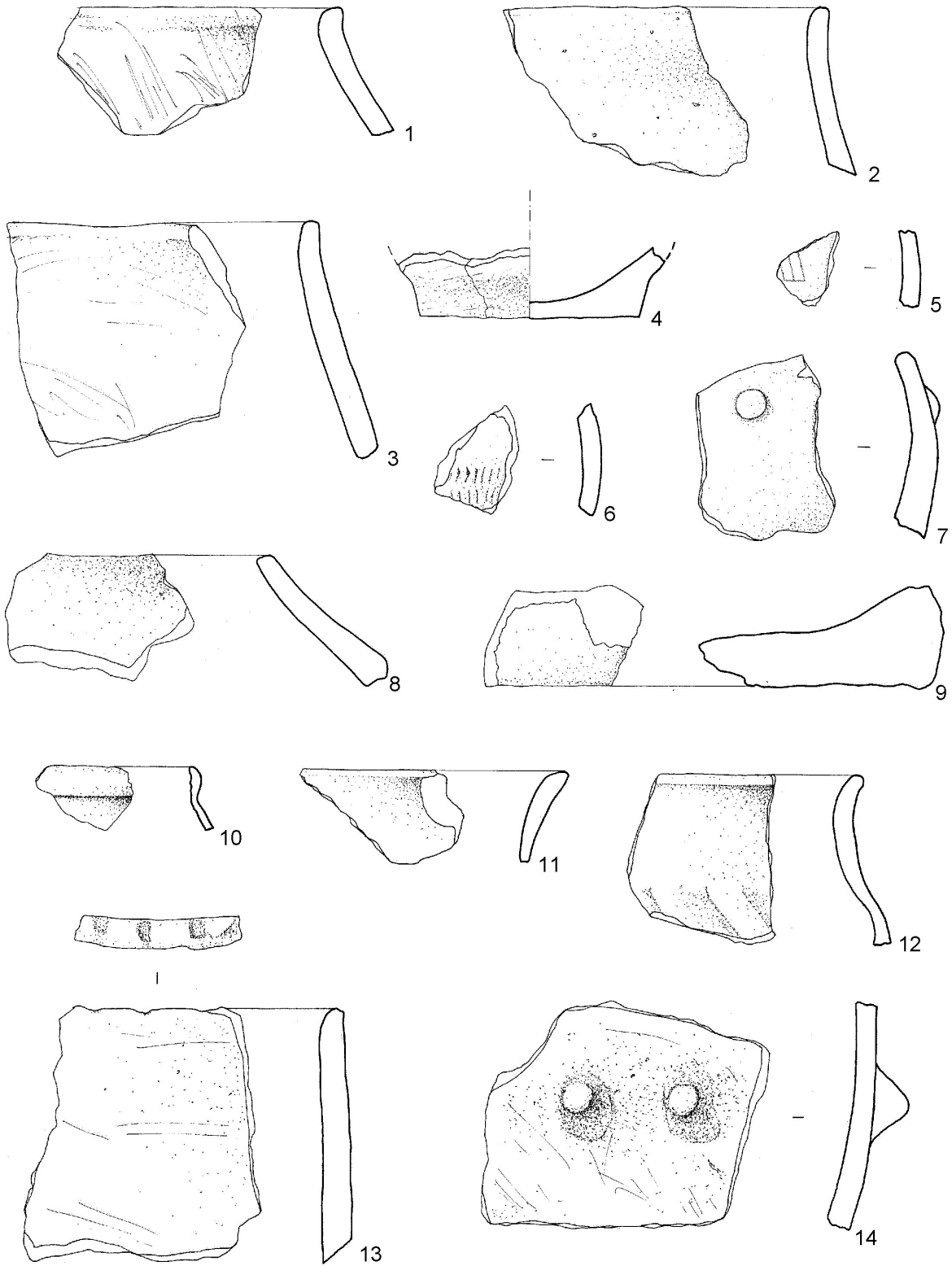

LITERATURA / LITERATURE

- ASPES, A., 1984. *Il Veneto nell'Antichità, Preistoria e protoistoria I*. Biblioteca Popolare di Verona, Verona.
- BAČIĆ, B., 1956. Arheološko iskopavanje spilje Cingarele kod Momjana. *Jadranski zbornik* 1, 323 – 364.
- BAČIĆ, B., 1969. Medulin, Ižula, Istra – neolitsko naselje. *Arheološki pregled* 11, 23 – 24.
- BAČIĆ, B., 1973. Vela Gromača kod Kavrana. *Histria archaeologica* IV/1, 7 – 29.
- BAČIĆ, B., 1976. Limska gradina (Istra) – neolitski lokalitet. *Arheološki pregled* 18, 34 – 37.
- BAČIĆ, B., 1997. Prahistorijska izložba. U: Ujčić, Ž. (ed.), *Arheološki muzej Istre - Vodič III*, 29 – 52. Pula, Arheološki muzej Istre.
- BATOVIĆ, Š., 1979. Jadranska zona. *Praistorija jugoslavenskih zemalja II, Neolit*, 473 – 632.
- BIAGI, P., VOYTEK, A., 1994. *The Neolithisation of the Trieste Karst in North-Eastern Italy and its neighbouring countries*, Jóna András Múzeum Évkönyve.
- BUDJA, M., 1998. Clay tokens-accounting before writing in Eurasia. *Documenta Praehistorica* XXV, 219 – 232.
- BUDJA, M., 2003. Seals, contracts and tokens in the Balkans Early Neolithic: where in the puzzle. *Documenta Praehistorica* XXX, 115 – 130.
- BURŠIĆ-MATIJAŠIĆ, K., 1994. La ceramica a striature in Istria. *Atti della XXIX riunione scientifica, Preistoria e protoistoria del Friuli-Venezia Giulia e dell'Istria, 28 - 29 Settembre 1990*, Firenze, 247 – 260.
- BURŠIĆ-MATIJAŠIĆ, K., 1993. Clay seals of Caput Adriae. *Poročilo o raziskovanju paleolita, neolita in eneolita v Sloveniji* XXI, 7 – 14.
- BURŠIĆ-MATIJAŠIĆ, K., 1998. *Gradina Monkodonja*. Monografije i katalogi 9, Pula.
- CODACCI-TERLEVIĆ, G., 2012. *Od pintadera do prehrane*. Katalogi Edukacijskog odjela 10, Pula.
- CORNAGGIA CASTIGLIONI, O., 1956. Origini e distribuzione della pintaderas preistoriche “euro-asiatiche”. *Rivista di Scienze Preistoriche* XI, 109 – 192.
- CRISMANI, A., 2001. I segreti della grotta di Nugla in Istria: le ricerche di Alberto Puschi e di Karl Moser. *Atti dei Civici Musei di Storia ed Arte di Trieste* no. 18, 161 – 199.
- CRISMANI, A., 2003. A proposito della Carta archeologica dell'Istria: un'indagine nella grotta di Cernizza. *Atti dei Civici Musei di Storia ed Arte di Trieste* no. 19 (2002 - 2003), Trieste, 271 – 284.
- ČOVIĆ, B., 1983. Srednje bronzano doba u Istri. *Praistorija jugoslavenskih zemalja IV. Bronzono doba*, 114 – 132.
- ČEČUK, B., RADIĆ, D., 2005. *Vela Spila, Višeslojno prapovijesno nalazište - Vela Luka, otok Korčula, Vela Luka*.
- ČUKA, M., 2009. Tipološka obrada odabranih ulomaka prapovijesne keramike iz pećine ispod sela Srbani. *Histria archaeologica* 40, 13 – 44.
- ČOVIĆ, B., 1983. Regionalne grupe ranog brončanog doba. 1. Istra. *Praistorija jugoslavenskih zemalja IV., Bronzono doba*, 114 – 132.
- FORENBAHER, S., 1999. “Nakovana culture”: state of research. *Opuscula archaeologica* 23-24, 373 – 385.
- FORENBAHER, S., KAISER, T., 2003. *Spila Nakovana. Ilirsko svetište na Pelješcu*, Zagreb.

- FORENBAHER, S., VRANJCAN, P., 1985. Vaganačka pećina – “Vaganačka” cave. *Opuscula archaeologica* 10, 1 – 21.
- GILLI, E., MONTAGNARI KOKELJ, E., 1996. La grotta degli Zingari nel Carso Triestino (Materiali degli scavi 1961 – 1965). *Atti Soc. Preist. Protost. Friuli-Venezia-Giulia IX, 1994 - 1995 (1996)*, 63 – 126.
- KOMŠO, D., 2003. Pećine Istre – mjesta življenja od prapovijesti do srednjeg vijeka. *Histria antiqua* 11/2003, 41 – 54.
- KOMŠO, D., 2004. Vrčevan – nalazište na otvorenom iz razdoblja ranog neolitika. *Histria archaeologica* 35/2004, 5 – 30.
- KOMŠO, D., 2006/1. Lokalitet: Kargadur. *Hrvatski arheološki godišnjak 3/2006*, 233 – 235.
- KOMŠO, D., 2006/2. Mezolitik u Hrvatskoj. *Opuscula archaeologica* 30, 55 – 92.
- KOMŠO, D., Miracle, P. T., 2004. Pećina Jačmica. *Hrvatski arheološki godišnjak 1/2004*, 150 – 153.
- KOMŠO, D., Miracle, P. T., 2006. Pećina Jačmica. *Buzetski zbornik. Knjiga trideset treća*, Buzet, 29 – 37.
- MAKKAY, J., 1984. *Early Stamp Seals in South-East Europe*, Akadémiai Kiadó, Budapest.
- MARIJANOVIĆ, B., 1981. Ravlića pećina (Peć Mlini). *Glasnik Zemaljskog muzeja Bosne i Hercegovine* 35/36, 1 – 97.
- MARIJANOVIĆ, B., 2007. Neka pitanja ranog neolitika istočnog Jadrana. *Archaeologia Adriatica* 1, 7 – 54.
- MARIJANOVIĆ, B., 2008. Pintadera iz Ravlića pećine. *Archaeologica Adriatica* II, 141 – 149.
- MARIJANOVIĆ, B., 2009. *Crno vrilo 1*, Zadar.
- MIHOVILIĆ, K., 1986. Pregled prahistorije Istre od starijeg neolitika do početka romanizacije. *Izdanja Hrvatskog arheološkog društva 11/1986*, 49 – 63.
- MIHOVILIĆ, K., 1994. Preistoria dell’Istria dal paleolitico all’età del ferro. *Atti della XXIX Riunione Scientifica*, Firenze, 101 – 118.
- MIHOVILIĆ, K., 2008. Nekropola u jami Laganiši. *Pećina Laganiši - mjesto života i smrti*. Katalog 73, Arheološki muzej Istre, 45 – 55.
- MIRACLE, P. T., FORENBAHER, S. 2006. *Pretpovijesni stočari sjeverne Istre, Arheologija Pupićine peći, 1. svezak*, Monografije i katalozi 14, Arheološki muzej Istre.
- MONTAGNARI KOKELJ, E., 2003. Why settling a Karstic area? Considerations on the Trieste Karst (north-eastern Italy) in the Late Prehistory. *Histria antiqua* 11, 75 – 93.
- MONTAGNARI KOKELJ, M., BOSCAROL, C., JURIŠEVIĆ E., 1976. Neolitico dei Vasi a Coppa/Vlaška (Carso Triestino, Italia Nord Orientale): vecchi dati e nuovi studi sulla ceramica. *Atti e Memorie della Commissione Grotte “E. Boegan”, Vol. 43*, 169 – 189.
- MÜLLER, J., 1991. Ostadriatische Impresso-Kultur: Zeitliche Gliederung und kulturelle Einbindung. *Germania* 69/2, 311 – 358.
- MÜLLER, J., 1994. Das Ostadriatische Frühneolithikum, Die Impresso-Kultur und die Neolithisierung des Adriaumes. *Prähistorische Archäologie in Südosteuropa*, Band 9, Berlin.
- OŽANIĆ ROGULJIĆ, I., 2011. Terra sigillata i keramika tankih stijenki s lokaliteta Crikvenica – “Igralište”. *Zbornik I. međunarodnog arheološkog kolokvija Rimske keramičarske i staklarske radionice*, 31 – 38.