

Energy Efficient Production – Interdisciplinary, Systemic Approach through Integrated Simulation*

Iva KOVACIC¹⁾,
Kristina OREHOUNIG²⁾,
Ardeshir MAHDAVI²⁾,
Friedrich BLEICHER³⁾,
Alexandros-Athanassios DIMITROU³⁾,
Linus WALTENBEREGE¹⁾

- 1) Institute of Interdisciplinary Construction Process Management, Vienna University of Technology, Karlsplatz 13, 1040 Vienna, Austria
- 2) Department of Building Physics and Building Ecology, Vienna University of Technology, Karlsplatz 13, 1040 Vienna, Austria
- 3) Institute for Production Engineering and Laser Technology, Vienna University of Technology, Karlsplatz 13, 1040 Vienna, Austria

iva.kovacic@tuwien.ac.at

Keywords

Sustainable manufacturing
Integrated simulation
Energy optimized production facilities
Industrial ecology

Ključne riječi

Održiva proizvodnja
Integrirana simulacija
Energetski optimirani proizvodni pogoni
Industrijska ekologija

Primljeno (Received): 2012-03-29

Prihvaćeno (Accepted): 2012-11-08

Original Scientific paper

Abstract: If the main concern of manufacturing companies was increasing the productivity, reliability, flexibility, and quality of the industrial process, more recently the energy efficiency of the production process and facilities has come under scrutiny. To enhance the energy-efficiency of production facilities, detailed information regarding the production processes, heat emissions from machines, operation level and occupancy analysis are necessary. In this context, the present paper describes an ongoing research effort that aims to develop a systemically integrated model of an energy efficient production facility. In this context we demonstrate the initial results of the implementation of an integrated simulation approach for a specific industrial facility. On the case study of an existing facility the different levels of energy in-and outputs were analysed; starting from machines and production systems, user behaviour and building services related requirements, to the building envelope of the facility. The collected information was further processed to develop a new building design. This layout provides the basis of an initial building performance simulation model. The generated model is part of the integrated simulation approach and used as a starting point to address the impact of different design and building operation options on the indoor climate and energy performance of the industrial facility. The goal of the integrated simulation approach is to evaluate a production facility not separately for individual mandates pertaining to production process, building envelope, and systems, but in a coupled and integrated fashion. Based on the results of thermal simulation, a first life-cycle costs model is developed, upon which the crucial points for the decision-making process in the planning of an energy-efficient industrial facility can be identified.

* **Energetski učinkovita proizvodnja – interdisciplinarni, sistemski pristup kroz integralnu simulaciju**

Izvorni znanstveni članak

Sažetak: Među glavnim interesima proizvodnih poduzeća do sada su bili povećanje produktivnosti, pouzdanosti, fleksibilnosti i kvalitete industrijskog procesa, a nedavno se pod povećalom našla i energetska učinkovitost proizvodnog procesa i pogona. U cilju poboljšanja energetske učinkovitosti proizvodnih pogona potrebne su detaljnije informacije o procesu proizvodnje, izmjeni topline u strojevima i analiza učinka i zastupljenosti pogona u radu. U tom kontekstu, ovaj rad opisuje istraživanje koje je u tijeku i teži razvoju sustavno integriranog modela energetske učinkovite proizvodnje u pogonu. U tom kontekstu prikazani su početni rezultati provedbe integriranog simulacijskog pristupa za određeni industrijski pogon. U početnoj studiji slučaja postojećeg pogona analizirane su različite razine ulaznih i izlaznih

podataka o energiji; uključujući strojeve i proizvodne sustave, ponašanja korisnika, učinkovitosti kućne tehnike te ovojnice zgrade pogona. Prikupljeni podaci dodatno su obrađeni u cilju razvoja novog građevinskog projekta. Prijedlog koncepcije novog pogona pruža osnovu za prikaz početnog učinka simulacijskog modela na zgradi. Razvijeni model je dio integriranog simulacijskog pristupa te se koristi kao početna točka u simulaciji utjecaja različitih koncepata organizacije prostora i volumena zgrade, kvalitete ovojnice zgrade i kućne tehnike na energetske učinkovitost industrijskog pogona. Cilj integriranog simulacijskog pristupa je procijeniti energetske performanse proizvodnog pogona, ali ne za pojedine zadaće koje se odnose na proces proizvodnje, ovojnicu zgrade i sustave, nego na povezani i integrirani način. Razvijen je prvi modela troška vijeka trajanja koji se temelji na toplinskim simulacijama, koji je presudan u procesu donošenja odluka u planiranju energetske učinkovitosti industrijskog pogona.

1. Introduction

Maximizing productivity has been the main objective to be considered when planning production facilities in the past. In this respect the reliability, flexibility, cycle time and the quality of the production process plays a significant role. The increasing uncertainty in energy supply through political dependencies, corporate social responsibility, tightening of EU regulations considering CO₂-reduction [1] and lastly the growing pressure from the media and increasing public ecological awareness have enhanced the inclination from maximization towards energy efficiency and life cycle optimization.

Due to the need for flexibility, transformation ability and the short reaction time to the rapidly changing demands of global markets, European industry has acted in terms of short-cycled strategies. Optimization along life-cycle, which would prove for energy and resources efficiency, would require a more long-term oriented decision-making process. An interdisciplinary collaboration using a systematic, life-cycle oriented approach therefore offers an appropriate method for achieving energy and resource savings for industrial processes and facilities. Therefore, we propose the systemic-integrated approach for life-cycle optimization of the industrial facility within the framework of the research project INFO (Interdisciplinary Research for Energy Efficiency in Production), at the Vienna University of Technology, supported by the Climate and Energy Fund. INFO aims to realize a systemically integrated model of an energy efficient production facility from the micro (comprising the production process and the machine tool) to the macro level (involving the production layout and the facility including building elements and building services). Thereby, the project consists of five main phases (analysis, modelling, coupled modelling, optimization, and implementation) in which machines, machining processes and the building will be addressed for the specific field of the metal cutting industry. As the final

outcome, an integrated simulation will be developed to serve as a managerial tool for the optimization of energy, emissions and costs of industrial facilities and in view of corporate strategies.

2. State of the Art

30% of worldwide energy consumption is attributable to industry, around 28% in Germany and Austria.[2,3] The industrial sector is largely dependent on fossil fuels, which in a European context are for the largest part imported; thus making European industry extremely dependent on supply. In order to meet the EU 20-20-20 aims [4], as well as to guarantee the supply-security and availability of energy, immediate steps are necessary. The development of more efficient, renewable-energy based technologies, cogeneration technologies, smart metering and smart grids for balanced supply, distribution and control can be seen as mid- to long term aims for achievement of a post-carbon society, due to the relatively slow development, though above all, practically slow implementation.

As a short term aim, the reduction of energy consumption in the industrial sector could be achieved through more efficient use of resources, optimization of process, operation and management and user behaviour change. For this approach, powerful computer tools for optimization and simulation of processes and energy flows are needed.

Connolly et al [5] analyse 37 tools for the assessment of renewable energy into various systems ranging from single building, power-plants, up to energy-systems including transport by electric vehicle. The authors build up a tool-typology, identifying seven types: simulation tools for given boundary conditions, scenario tools, equilibrium tools balancing supply and demand, top-down tools (macroeconomic), bottom-up (decision support), and operation optimisation (often simulation tools); and conclude that there is “no ideal tool” but only after thorough problem assessment a tool or even combination of several tools can be chosen for support of the decision making process.

As the method for optimization of industrial energy systems, MIND (Method for analysis of INDustrial energy system) method is being used for total system cost minimization, employing Mixed Integer Linear Programming (MILP). The MIND method is based on the structural network of nodes and branches; where the branches represent energy and material flows and the nodes the conversion processes [6]. Gong [6] identifies the lack of feedback-loops as the main limitation of the MIND method, and proposes the MIND/F model that includes the feedback and thus enables the recycling of energy and materials; a model tested in the pulp and paper industry. A Swedish tool reMIND, based on the MIND method, developed at Division of Energy Systems at Linköping University is used in several

industries such as foundry, steel, pulp and paper mills and district heating systems in order to find the optimal operation strategy in dependence upon changing boundary conditions, such as fuel price [7].

The mathematical MILP models were already used for modelling and optimization of the refinery with a cogeneration unit [8], multi-period optimization of by-product gas in iron and steel industry [9], and collaboration modeling between CHP plants located in different sites [10].

For the optimisation of production processes and material and energy flows, a discrete event simulation (DES) is often used. DES simulates the behaviour of events at distinct points of time. Between events nothing happens, time does not proceed linearly but in irregular intervals [11]. The main discrete event simulation application areas are: material flow simulation, manufacturing system analysis, and information flow simulation. These applications can be decomposed into smaller, more precise tasks to examine, e.g., inventory, work in process, queues or transporting time. [12].

Both literature and current research suggest the **integrated approach** as a viable solution for the achievement of more sustainable solutions in the industrial sector. The integrative approach addresses several fields: process integration – efficient use of raw materials, emission reduction, process operation, energy-efficiency [13], addressing integration of the thermodynamic approach and mathematical programming, integration of renewable energy into energy-systems and integration of utilities and production process. The sequential, traditional approach still applied in the planning of industrial facilities has been strongly criticised in terms of fitness for achievement of energy-efficiency. The maximization of the productivity still dictates the utilities performance [14] as well as the structural design of industrial processes and buildings due to the low energy prices.

Several research projects in a national and international framework are focusing on the enhancement of energy-efficiency and sustainability in production using an integrated approach. The German research project “Planning guideline Future Industrial Building” [15] identifies particularly the fragmented, sequential planning process as the weakest point in the framework. According to the “Advanced Energy Design Guide for Small Warehouses and Self-Storage Buildings” [16], up to 30% of energy savings could be reached through an integrated planning process consisting of several life-cycle stages: design – construction – acceptance – occupancy – operation.

The Finnish project BestServ proposes the highly integrated model “Industrial Service development” of resources-, time- and space sharing facility as flexible production cluster [17], visualising not only energy, but also time and space as scarce resources. In further steps,

the so called CMS Hotel concept is developed as a new type of factory supporting sustainable businesses producing “green products” through a clean production process and optimized delivery chain. The concept is based on a systemic and holistic approach, involving even regional development in the context of the eco-city [18].

In the realm of the textile industry, a comparative study of the production processes of German and Colombian facilities shows the importance of technology, energy efficiency-oriented policies and management strategies in improving energy efficiency [19]. In the metal cutting industry, large amounts of waste heat, originating from heat intensive processes such as hardening or painting/coating processes, are already being used for the heating of factories and neighbouring offices or for warm water preparation. Projects such as Eco2cut (Ecological and economical machining) [20] focus on the optimization of energy consumption of the machine and of the process. The goal of the project is the realization of the manufacturing processes with increased energy-efficiency from the aspect of enhanced environmental sustainability. Through detailed measurements, the energy consumers are identified by such distinctions as high loads in the standby mode. This issue has also been exploited by Siemens by the so called “Shut down factory” [21] concept where strategies have been developed in order to reduce costs due to the high energy consumption of energy consumers in the standby modes through implementation of control and communication systems for the shut down and start up modes.

For achievement of truly sustainable production in an economic, ecological and social sense, it is necessary to redefine the system and time limits towards mid- and long term strategies; instead of short time horizons as currently still is the practice. The US study on the implementation of the recommended measures for the improvement of energy efficiency shows that “... the probability of implementing a suggested recommendation to a company is mainly dependent on the recommendation's payback period as it is found that 64% of the implemented recommendations have a payback period of 1 year or less” [22].

There is a large gap between the research results and proposed models and the actual needs and possibly of implementation in the industry. As Agha et al point out [13], the implementation of the integrated approach in practice requires extensive use of computer aided tools and intensive communication of different levels of management; which might both be perceived as obstacles in centralised organizational structures.

Bunse et al [23], go even further in their study of the integration of energy-efficiency measurements in production management, concluding that the existing solutions in the literature contrast with the industry needs; the existing tools for measurement, control, and

the improvement of manufacturing processes are generally not suitable for energy management in the production of the company, plant or process level due to the lack of practicability and comprehensiveness. New approaches should be developed, based on the extension of the scope of simulation tools towards: sensor technology and monitoring software, evaluation of performance data, and management concepts for improvement of strategies. The integration of management concepts with energy-efficiency as a strategic factor together with technology, in collaboration with academic research and industry are the necessary steps for the achievement of sustainable production.

3. Scope of study and method

Within this paper the potential benefits of coupled simulation will be explored based on an illustrative parametric simulation case study including a life-cycle cost analysis of an industrial production facility. The goal of the INFO project is to evaluate a production facility not separately for individual mandates pertaining to production process, building envelope, and systems, but in a coupled and integrated fashion. Therefore, multiple sub-models including the production process, the thermal performance of the building, the HVAC (heating, ventilation, air conditioning) systems, and the management instruments will be generated. For data exchange between the separate models, the "Building Controls Virtual Test Bed" (BCVTB) [38] will be considered within a continuous, dynamic simulation. Especially advantageous is this type of simulation for the building simulation due to disturbances such as user behaviour, or longer time constants like weather data. The continuous simulation can be carried out over longer time horizons, thus enabling the long-term scenario evaluation. In this way, long-term benefits such as eco-efficiency can be generated, opposed to the short-term oriented ROI, as a traditional decision-making parameter. Integrated simulation is a decision supporting tool for the planning of new energy- and resources efficient facilities, whereas the most existing models optimise the existing manufacturing process.

The analysis of production processes and energy profiles of the existing facility was used for the definition of the parameters for the design of a new facility, which again served as the generic model for thermal building performance simulation. Based on the results of thermal building simulations (several scenarios involving different façade types and operational schemes), the first life-cycle costs (LCC) model was developed, upon which the crucial points for the decision-making process in the planning of the energy-efficient industrial facility could be identified.

Figure 1 shows the research steps and analysis, as well as the first simulations carried out in this study, which will serve as sub-models for the integrated simulation.

As a starting point, the case of the existing facility was analysed in terms of work flows (delivery, storage, and production), energy flows (consumption, waste heat), emissions (oil, dust, humidity, noise, and heat losses), and occupancy parameters (working hours and shifts for offices and production). Measurements of the heat emissions from the machines (lasers, machine centres, etc.) were conducted over a period of multiple weeks. The collected information was further processed to develop an adequate layout for the new industrial facility, which was carried out through Building Information Modelling (BIM)[24].

The generated model provides the basis for the initial building performance simulation and is used to address the impact of different design options (façade types, window to wall ratio, roof options, HVAC systems, etc.) and building operation options (ventilation strategies, window shading, lighting control, etc.) on the indoor climate, comfort ramifications (thermal and visual) and energy performance of the industrial facility. Initial results show the potential in the reduction of the heating and cooling loads of the aforementioned production facility via the proper configuration of building design features.

The predicted implications of these options (specified in terms of scenarios) for savings in building's heating and cooling demand (minimized according to costs) can thus be evaluated and compared with possible higher investment costs for building construction (in this case the building envelope). In the first exploration of life-cycle costs, several options of facades were calculated in terms of life-cycle using the alternatives-evaluation approach.

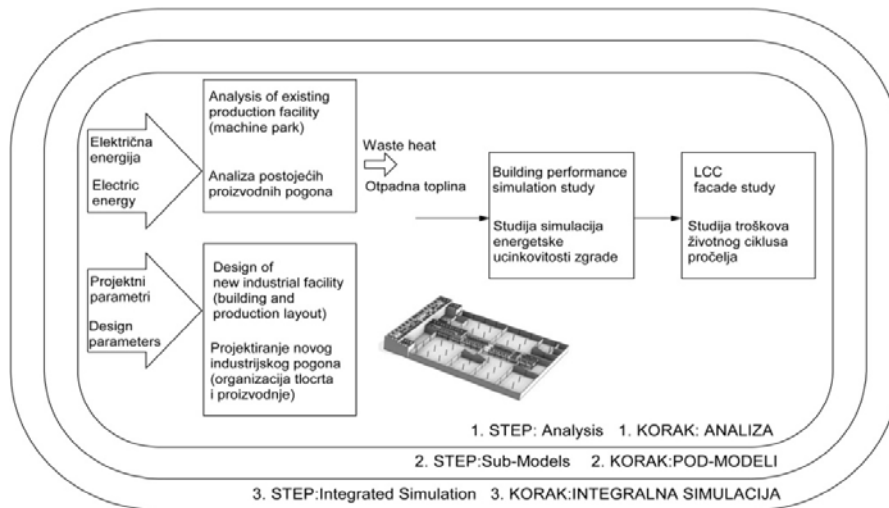

Figure 1. Research model

Slika 1. Model istraživanja

4. Analysis of an existing production facility

An important factor in improving the energetic performance of production facilities is the consideration of thermal loads emitted into the building by the machines and the machining processes. Assessments of various metalworking machines and lasers were performed by the Institute of Production Engineering and Laser Technology (IFT) in order to analyze the energy distribution within the machine tools, quantify the amounts of emitted heat and to identify the key potential areas for improvement.

4.1. Background

Machinery for metalworking (e.g. milling and turning) acts as a considerable heat source in a

production facility. As studies by the IFT on the topic of energy flows within the machine tools have confirmed, the only fraction of the machining energy that goes into a chip and is not converted into heat is the energy of the plastic work associated with the chip deformation [25]. This fraction can be assumed to vary between 3 and 30% of the machining energy, as depicted in Figure 2 [26], [27].

The energy that is required in chip formation is far from the total energy required in production. For these processes, additional energy must be provided to power auxiliary equipment for work piece handling, cutting fluid handling, chip handling, tool changers, computers, cooling equipment and machine lubrication systems [28],[29].

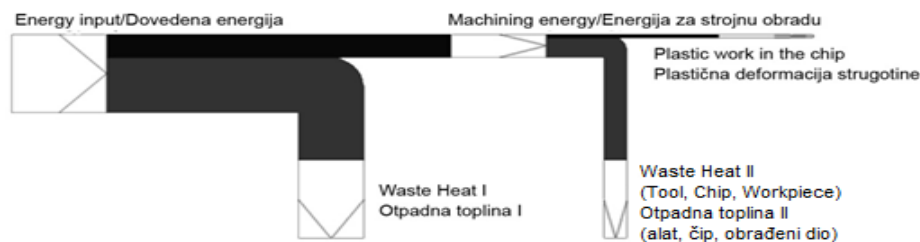

Figure 2. Energy flow in a machine tool during the machining process

Slika 2. Energetski tok u alatnom stroju tijekom postupka strojne obrade

By accounting for these factors, it can be assumed that between 70 and 97% of the total net energy for the machining of a part is converted into heat, since energy cannot be stored within the machine tool. This transformation occurs along the components of the power train, with losses of energy mainly due to friction and electrical resistance, shown in Fig 3. With regard to the chip formation itself, the build-up of heat takes place

at the chip formation zones, due to deformation and friction processes.

By considering the machining time in metalworking, the fraction of the plastic work is reduced even further. In general it can be assumed that all of the electrical energy input in a production facility in metal processing (machining and laser cutting) will subsequently be emitted into the factory in the form of heat.

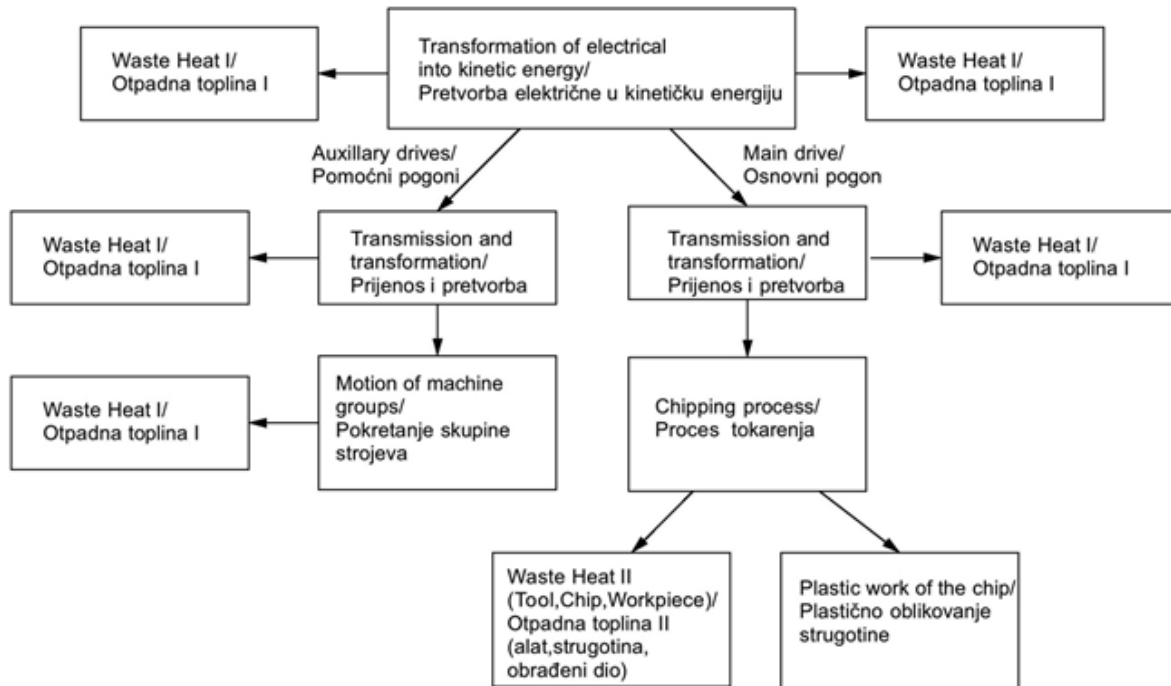

Figure 3. Energy transformation in machine components

Slika 3. Pretvorba energije u strojnim dijelovima

4.2. Analysis

Within the research project "INFO" an existing production facility in the area of metalworking has been analysed with the objective of assessing the influence of heat emissions from the machinery. To integrate this dynamic interaction into the model, a method of recomposing individual measurements to production scenarios that describe the emitted heat as a function of the electricity consumption has been developed at the IFT. To reproduce these scenarios from measurements, the following data is of importance:

- machining intensity and machine usage

- number of shifts

Data regarding the production process, machines, shifts and operating schedules, occupancy, electricity consumption and production output was therefore collected; Figure 4 illustrates how this data is integrated. The recomposed scenarios allow us to model the energy consumption of the machinery under current circumstances and also to forecast future consumption and the associated heat emissions.

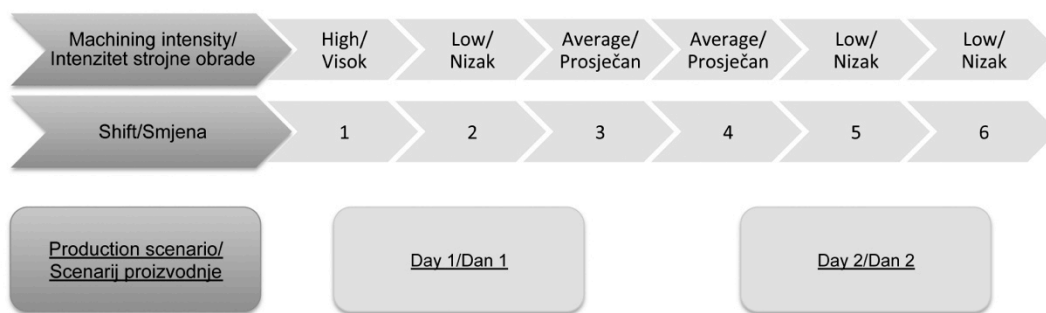

Figure 4. Machining scenario components

Slika 4. Scenariji dijelova strojne obrade

4.3 Measurements

In order to assign energy profiles to the machinery, measurements were conducted for individual machines that were of particular interest, and also for the entire train of machines of the investigated facility.

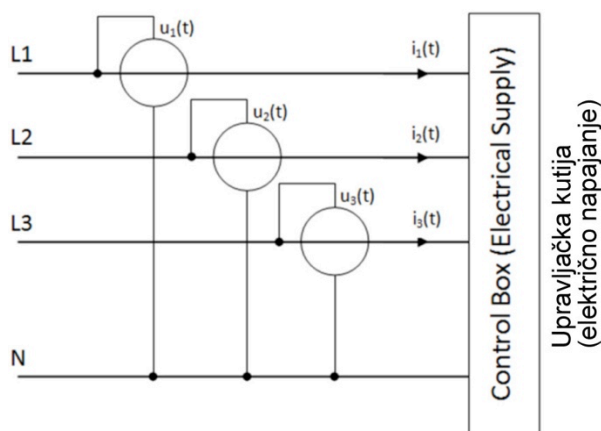

Figure 5. Measurement setup

Slika 5. Podešavanje mjerenja

The measurements were conducted using the tree-wattmeter principle as shown in Figure 5, by simultaneous measurement of the current and the voltage of all three phases, therefore also allowing the accurate measurement of unbalanced loads. The time resolution was chosen with 50 ms for measurements of individual machines, and 1s for the measurement of the whole machine train. The graph in Figure 6 shows the resulting power input [kW] for a specific group of machines. The measurement curve in Figure 6 shows high fluctuation of the energy input, with values ranging from 90 to 200 kW. The total energy input for the measurement week resulted in a mean value of approximately 80 kW. Since the utilization of the machines during the weekend was low, the resulting average values of approx. 110 kW for weekdays were determined after the measurement was weighted accordingly. As noted above, other data from the management allowed a more exact estimate of the appropriate weighting and the energy requirements in certain production scenarios.

The same concept was applied for other machine groups, corresponding to the building zones in order to model the thermal loads generated by the machinery.

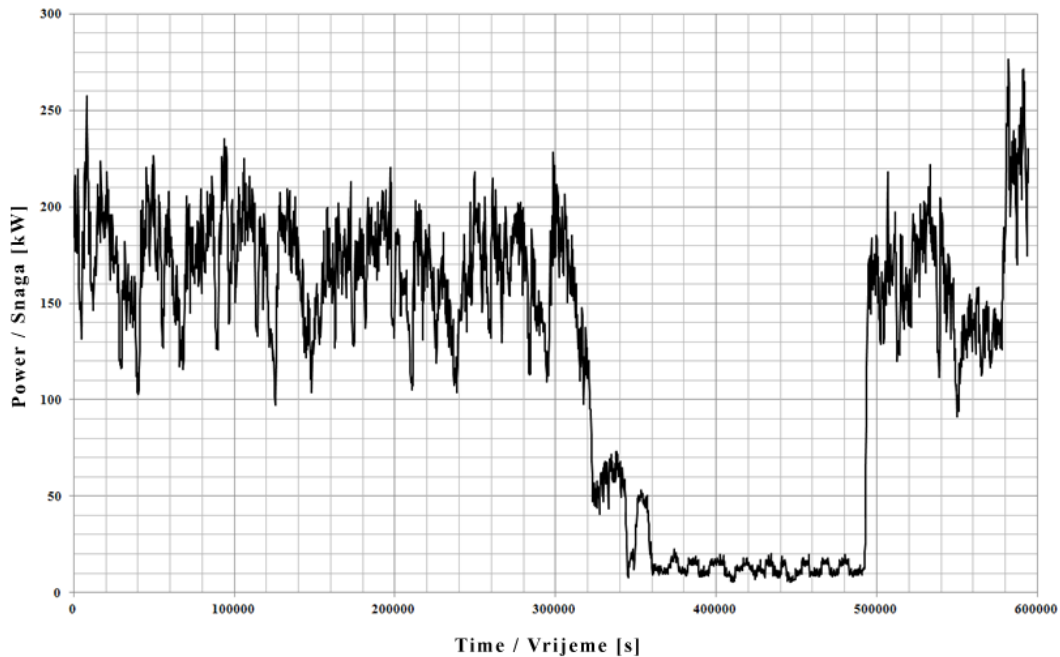

Figure 6. Power measurement over one week

Slika 6. Izmjerena snaga tijekom jednog tjedna

5. Design of new facility

A parametric 3D model allowing the representation of interactive, data-rich elements was used for the modelling of an “ideal” facility using BIM software tools. These were chosen due to the numerous identified advantages such as improvement of the collective understanding of design intent by 69% through BIM implementation, and improved interoperability between software applications by 76% [30]. The planning parameters for the new facility were based on a collection of tangible (quantitative) and intangible (qualitative) data. The tangible data related to the energy demand, diverse emissions, machine floor layout, occupancy profiles, and quantitative space demands were gathered in the case-analysis of the existing facility. The intangible data such as functionally, corporate identity, space qualities, and future development was collected through a client briefing process. The client briefing resulted in the following planning aims:

- Maximization of communication among the areas for research and development (R&D) and the production hall.
- High flexibility of production areas – modular principle – due to the flexibility of the production

process and very short product life cycles; the specialized production areas must be able to adopt new or even completely different functions and uses with minimal re-fitting effort. For example, the area for metal cutting must be transformable into storage if necessary.

- Expandability of the production facility as well of office and R&D spaces – since the specific company is constantly growing, the expansion phases have to be considered already in the pre-design. In close relationship to this aspect, special focus is to be paid to recyclable and reusable façade.

After the briefing process, a functional and spatial program, in the form of a list of areas proposed; upon which an ideal layout (organizational chart) depicting the areas, relations between spatial units and functions has been developed. Finally, a real layout, considering the location and infrastructure together with building orientation and micro-climatic conditions was compiled (Figure 7). The proposed solution consists of an office block facing north, with production hall continuing on the vertical axis. The office block with the main entrance for employees and customers is oriented

towards the neighbourhood, consisting of mainly offices. In this way, the shortest routes from parking spaces and public transportation (underground) are

enabled as well as preventing noise and emissions from being expelled towards the neighbourhood (Figure 8).

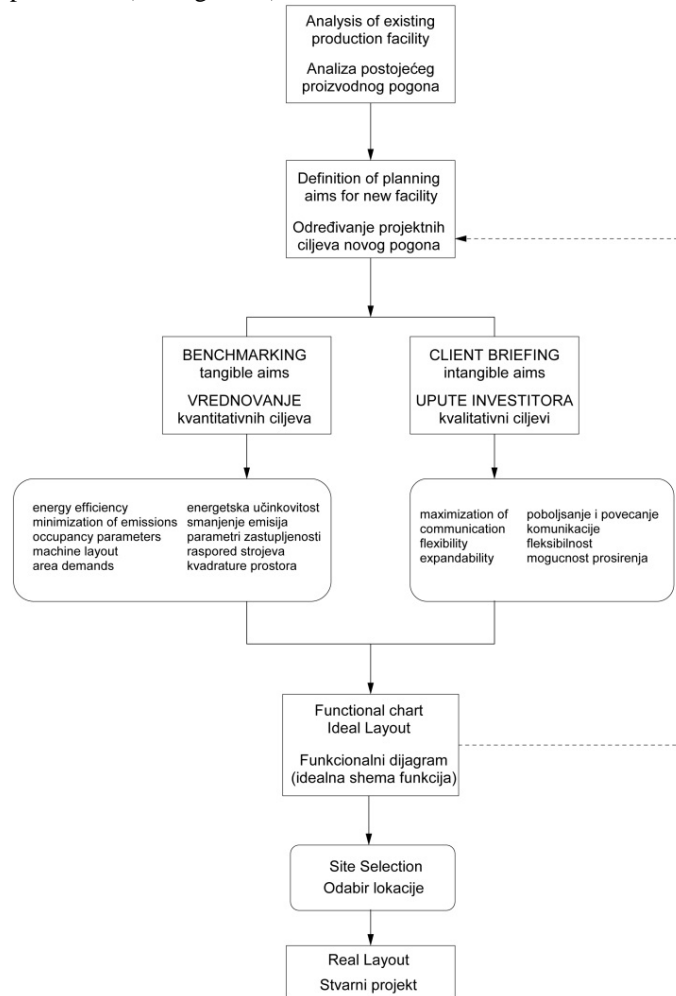

Figure 7. Diagram of the planning process for new facility

Slika 7. Dijagram procesa planiranja novog pogona

The innovative aspect represents the introduction of the “bridge” – R&D offices suspended directly in the production hall, enabling direct visibility but also over the short distance, a personal connection to the production. The flexibility is maximized through modular construction of 15 x 15 meter modules.

Expansion in both the east and west directions is possible (Figure 9).

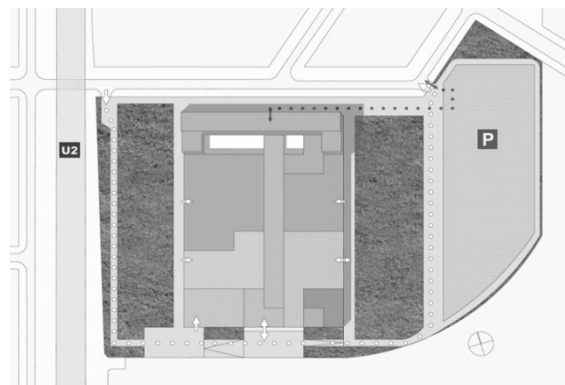

Figure 8. Site plan of the specific industrial facility

Slika 8. Tlocrt novog industrijskog pogona

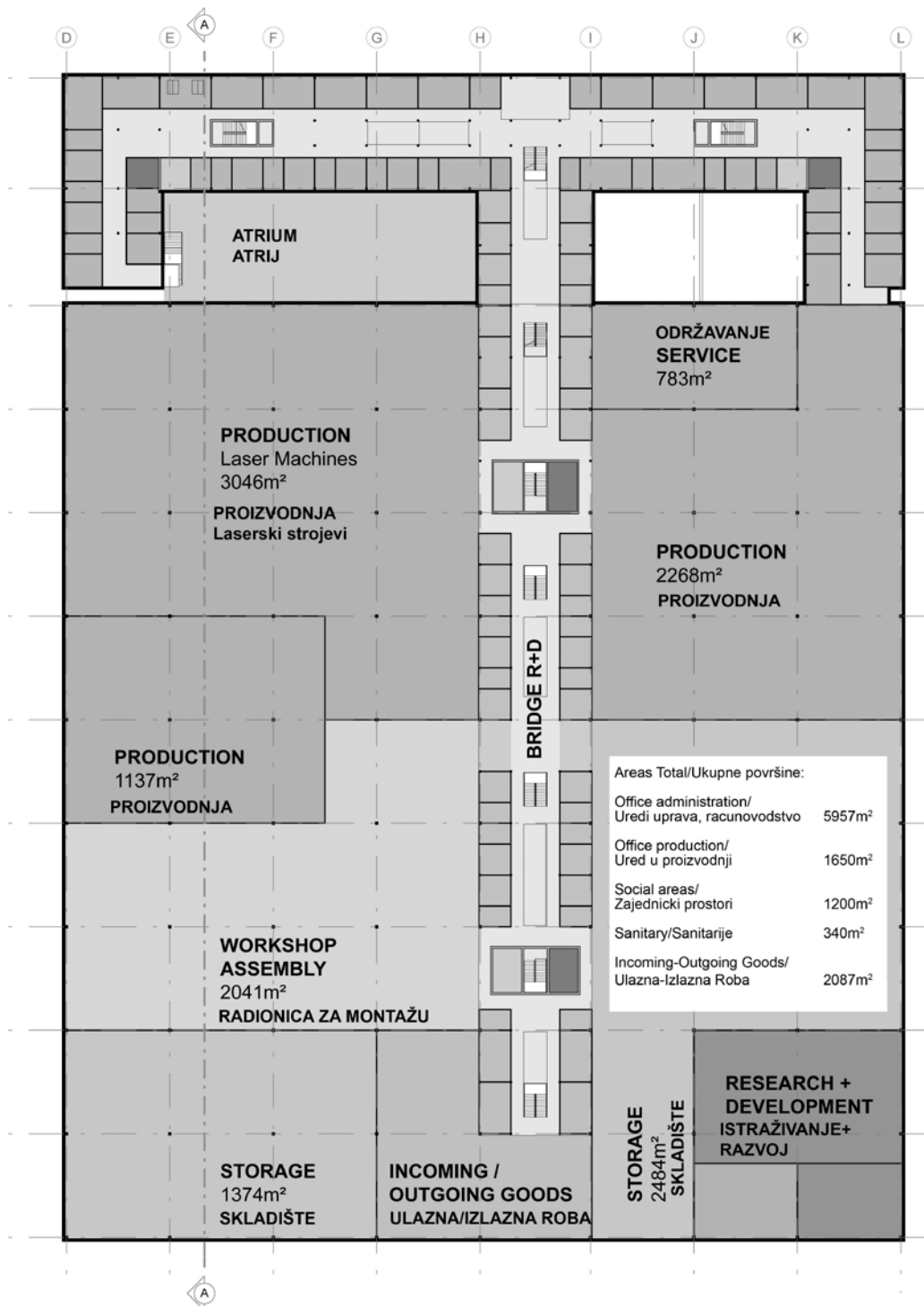

Figure 9. Floor Layout

Slika 9. Tlocrt funkcionalne organizacije

The shed roof-construction allows maximum daylight through glass surfaces oriented northwards, whereas slopes towards the south offer surfaces for PV and solar energy production. In this way, north light is brought

into the hall, which prevents summer overheating (Figure 10). Small atria through the communication bridge could be used as social spaces, but also for nightly cooling.

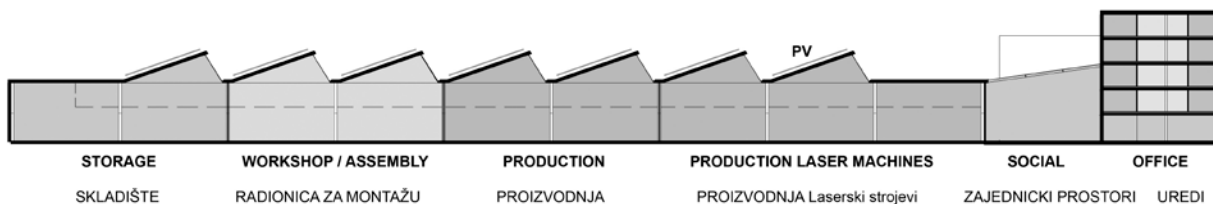

Figure 10. Longitudinal Section

Slika 10. Uzdužni presjek

6. Building performance simulation study

To illustrate the process, a layout option was developed for the aforementioned model building (see Figure 8). This layout provides the basis of the respective thermal performance simulation model. Toward this end, model input assumptions are made according to the following structure:

1. Geometry and "Semantic" properties of the building elements and components (e.g. thermal conductivity, density, and specific heat capacity of components' constitutive layers)
2. Internal gains, i.e. heat emission rates associated with people, lighting sources, and – particularly important in the present case – of machines and devices for industrial production. Our initial exploration in this domain illustrates a significant lack of available empirical information regarding the heat emission associated with industrial machines and processes (together with information regarding the operation schedules of such equipment). These unknown rates, however, have a significant impact on the simulation results (e.g. heating and cooling demands) and must thus be carefully represented in the building simulation models.
3. Systems: HVAC systems can be modelled at different levels of detail and resolution. In the initial optimization phase, such systems may be represented in terms of aggregate efficiency parameters. At a subsequent stage, such systems will be modelled in more detail.
4. Weather data: To run the simulations, a detailed (hourly) weather file is used [31].

For the above mentioned sample building, geometry and construction data provide the basis for the generation of a thermal simulation model [32]. The industrial facility

is assumed to operate in three shifts, namely, shift 1 from 6 am to 2 pm, shift 2 from 2 pm to 10 pm, and shift 3 from 10 pm to 6 am. Assumed input data regarding U-values, maintained illumination levels, and set-point temperatures are summarized in Table 1.

Table 1. Simulation input data pertaining to U-values of constructions, illumination levels and gains, and set-point temperature

Tablica 1. Simulacija ulaznih podataka koji se odnose na U-vrijednosti ovojnice zgrade, razinu osvijetljenosti,

U-value roof/U-vrijednost krova [$\text{W}\cdot\text{m}^{-2}\cdot\text{K}^{-1}$]	0.2
U-value floor/ U-vrijednost poda [$\text{W}\cdot\text{m}^{-2}\cdot\text{K}^{-1}$]	0.26
U-value window/ U-vrijednost prozora [$\text{W}\cdot\text{m}^{-2}\cdot\text{K}^{-1}$]	1.6
U-value roof lights/ U-vrijednost krovnih prozora [$\text{W}\cdot\text{m}^{-2}\cdot\text{K}^{-1}$]	1.3
Maintained illumination level/ Razina održavanja osvijetljenosti [lx]	250
Internal gains (lighting)/ Unutarnji dobici (rasvjeta) [$\text{W}\cdot\text{m}^{-2}$]	12
Set-point heating during occupancy/ Podešena temperatura grijanja za vrijeme korištenja prostora [$^{\circ}\text{C}$]	18
Set-point heating set back/ Podešena temperatura grijanja smanjenog intenziteta [$^{\circ}\text{C}$]	12
Set-point cooling during occupancy/ Podešena temperatura hlađenja za vrijeme korištenja prostora [$^{\circ}\text{C}$]	28
Set-point cooling set back/ Podešena temperatura hlađenja smanjenog intenziteta [$^{\circ}\text{C}$]	32

unutarnje dobiteke i potrebne vrijednosti temperature

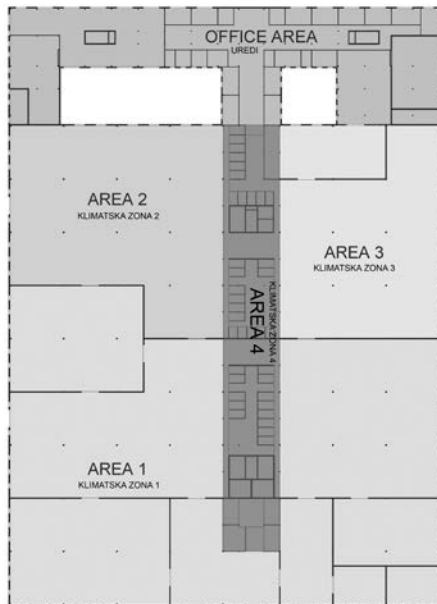

Figure 11. Plan of the industrial facility

Slika 11. Plan industrijskog pogona

The industrial hall was divided into 4 main areas: Area 1 is dedicated to the assembly of the end products. This area is assumed to accommodate small equipment such as drilling machines. In Area 2, six laser machines are accommodated which operate 5 days per week. Area 3 contains production equipment. Area 4 consists of office areas and associated service areas. Figure 10 shows the four areas marked on the floor plan.

Heat emission rates were summarized based on the one week of measurement period. The resulting values are summarized in Table 2.

Parametric simulations were used to compute the relative impact of various options and measure the differences in the energy demand of the industrial facility. Such options included façade type, glazing area, shading, lighting control, and natural ventilation. Accordingly, a number of scenarios were generated, as summarized in Table 3. These scenarios differ in terms of façade type, window area (in terms of the percentage of glazing in the façade), the assumed air change rate (with effective air change rates ranging from 0.2 to 1 h⁻¹), as well as the presence or absence of lighting and shading controls. The lighting control scheme operates the electric lights according to the availability of daylight, and maintains an indoor illumination level of 250 lx. The shading control option operates the shades once the incident irradiance on the façade goes beyond 120 W.m⁻². Descriptions of different façade types are summarized in Table 4.

Table 2. Simulation input data pertaining to internal gains and occupancy

Tablica 2. Simulacija ulaznih podataka koji se odnose na unutarnje toplinske dobitke i intenzitet korištenja

Area/Površina		Area 1	Area 2	Area 3	Office area/ Površina Ureda
Area [m ²]		9095	3026	2252	3312
Nr. of zones/ Broj područja		7	1	1	2
Hours of operation per day/ Radni sati u danu		24 h	24 h	24 h	12 h
Heat emission rates/ Mjera toplinskog zračenja [W.m ⁻²]	Week-days /Radni dani	10	37	49	15
	Week-end/ Vikend	10	0	5	0
Area per person/ Površina po osobi [m ²]		100	1000	100	10
Description/ Opis		Work-Shop/ Radionica	Laser Machines/Laserski strojevi	Machine Centers/ Strojna središta	Office/ Ured

Table 3. Scenarios for simulation runs**Tablica 3.** Scenariji za simulacije

	Facade type/ Tip pročelja	Percentage of glazing/Postotak ostakljenja [%]	Additional polycarbonat/ Dodatni polikarbonat [%]	ACH [h ⁻¹]		Lighting control/Kontrola osvjetljenia	Shading/Zasjenjenje
				Summer/Ljeto	Winter/Zima		
S1	A	10	-	1	0.2	YES	YES
S2	A	15	-	1	0.2	YES	YES
S3	A	20		1	0.2	YES	YES
S4	A	10	25	1	0.2	YES	YES
S5	A	10		1	0.2	NO	NO
S6	A	15		1	0.2	NO	NO
S7	A	20		1	0.2	NO	NO
S8	A	10	25	1	0.2	NO	NO
S9	B	15		1	0.2	YES	YES
S10	B	15		1	0.2	NO	NO
S11	C	15		1	0.2	YES	YES
S12	C	15		1	0.2	NO	NO
S13	C	15		0.5	0.5	NO	NO
S14	C	15		0.2	0.2	NO	NO
S15	C	15		0.5	0.2	NO	NO
S16	C	15		1	0.2	YES	NO
S17	C	15		1	0.2	NO	YES

Table 4. Variation of façade options**Tablica 4.** Mogućnosti izmjene pročelja

Façade type/Tip pročelja	Exterior panel/Vanjska ploča	Insulation/Izolacija	U-value/ U-vrijednost [W m ⁻² K ⁻¹]
A	Metal/Metal	Mineral wool/Mineralna vuna	0.26
B	Metal (zinc coated)/ Metal (prevučen cinkom)	Polyurethane foam/Poliuretanska pjena	0.1
C	Metal (zinc coated) /Metal (prevučen cinkom)	Wood fiber insulation panel/Izolacijska ploča od drvenog vlakna	0.27

Figures 12 and 13 show the simulated annual cooling and heating loads [$\text{kWh}\cdot\text{m}^{-2}\cdot\text{a}^{-1}$] for all scenarios (as per Table 3).

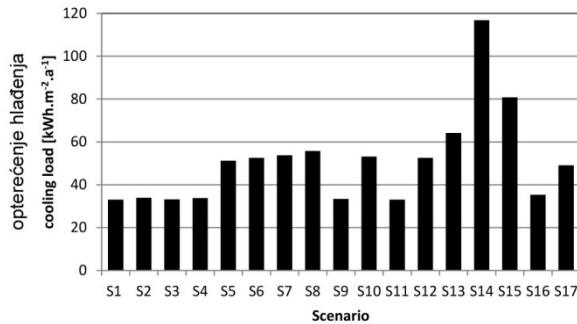

Figure 11. Simulated annual cooling load (area 1-3) for all scenarios [$\text{kWh}\cdot\text{m}^{-2}\cdot\text{a}^{-1}$]

Slika 11. Simulacija opterećenja hlađenja kroz godinu (klimatske zone 1-3) za sve scenarije [$\text{kWh}\cdot\text{m}^{-2}\cdot\text{a}^{-1}$]

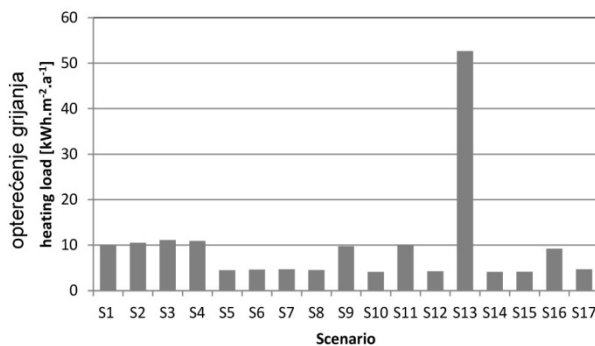

Figure 12. Simulated annual heating load (area 1-3) for all scenarios [$\text{kWh}\cdot\text{m}^{-2}\cdot\text{a}^{-1}$]

Slika 12. Simulacija opterećenja grijanja kroz godinu (klimatske zone 1-3) za sve scenarije [$\text{kWh}\cdot\text{m}^{-2}\cdot\text{a}^{-1}$]

The simulation results of different scenarios lead to a number of observations:

Comparison of different glazing percentages in the façade does not show significant differences in terms of cooling and heating loads. For example, scenarios S1 (10% glazing) and S2 (15% glazing) display similar loads. Likewise, scenarios S5 (10% glazing) and S8 (10% glazing and 25% polycarbonate glazing) are rather similar in view of the resulting loads. The same holds true for different façade types (S2, S9, and S11), as they do not display noteworthy differences in terms of cooling and heating loads. This is in part due to the building's high compactness and high internal loads.

Higher ventilation rates in the winter result in high heating loads. An increase in the air change rate from 0.2 h^{-1} (S12) to 0.5 h^{-1} (S13) resulted in a heating load increase of approximately $50\text{ kWh}\cdot\text{m}^{-2}\cdot\text{a}^{-1}$. However, lower ventilation rates result in an increase in cooling loads (scenarios S13 and S14). Scenario 12 (with low ventilation rates in winter and high ventilation rates in summer) displays both a considerable heating load reduction and a modest reduction of the cooling load.

Scenario S16 with the lighting control feature reduces internal gains due to daylight activated lighting, thus reducing cooling load and increasing heating load. Additionally, the scenario shows that, in this case, energy demand for lighting could be reduced by 38% if proper lighting control measures are implemented.

Automated operation of external shading reduces solar gains and thus results in a slight cooling load reduction. The best performing scenarios in the present study are S9 and S11, which combine features such as lighting and shading control together with effective ventilation regimes, reducing thus both heating and cooling demand.

These results display, in a simplified manner, the potential of building design and operation optimization via parametric simulation-assisted analysis of candidate designs and available technological alternatives.

7. Life-cycle costs of building envelope

Based on the results of the simulation study, the façade could be identified as an important building-construction element determining the building performance of the building. It incorporates the features of shading, natural ventilation and glazing, which again have the main impact on the saving potential and therefore on the life cycle costs.

Due to great internal heat gains, the impact of thermal insulation on energy consumption for heating and cooling is negligible (comparing scenario 9 and scenario 11). Using the alternatives-evaluation approach three facades systems (Table 5) for the preliminary planned facility as described in chapter 4 were compiled and compared using the net present value approach [33].

To provide for LC-cost comparability, three façade alternatives feature the same parameters:

- Integrated electrical shading devices,
- Automated windows with the same percentage of glazing,
- Similar thermal standard considering the heat transfer coefficient (U-values differ due to thermal bridges and product specifications therefore a range is stated: between 0.27 and $0.31\text{ W/m}^2\text{K}$).

Table 5. Description of three façade systems and their investment costs and life cycle costs after 36 years of operation**Tablica 5.** Opis tri sustava pročelja: investicijski troškovi i troškovi životnog vijeka nakon 36 godina upotrebe

Façade type/ Tip fasade	Exterior panel/ Vanjska ploča	Structure/ Sastav	Shading/ Zasjenjenje	Insulation/Izolacija/ mm		U-value/ U- vrijednost $W m^{-2} K^{-1}$	Investment costs/ Investicijski troškovi Thousand/ tisuću EUR		LCC ₃₆ Thousand/ tisuću EUR	
A	3-layer wood panel/ 3-slojna drvena ploča	Steel liner tray/ čelični linijski blok	Horizontal lamellas /Horizontalne lamele	Mineral wool/ Mineralna vuna	180	0.27-0.32	921	+25%	1 435	+3%
B	Metal (zinc coated)/ Metal (prevučeni cinkom)	Steel/ čelik	Blinds/ žaluzine	Polyurethane foam (sandwich panel)/ Poliuretanska pjena (slojevita ploča)	100		694		1 389	
C	Metal (zinc coated)/ Metal (prevučeni cinkom)	Cross laminated timber/ Poprečno lamelirano drvo	Vertical lamellas/ vertikalne lamele	Wood fiber insulation panel/ Izolacijska ploča od drvenog vlakna	120		948	+27%	1 389	
Building model input/Ulazni podaci za model zgrade: Façade area: 3900 m ² ; glazing: 15%; number of windows: 98; number of operable windows: 49/ Površina pročelja: 3900 m ² ; ostakljenje: 15%; broj otkrivenih prozora: 98; Broj prozora: 49 Addition to type C: polycarbonate band-windows 10% of façade area/ Dodatak na tip C: prozori ispune polikarbonatnim pločama: 10% površine pročelja										

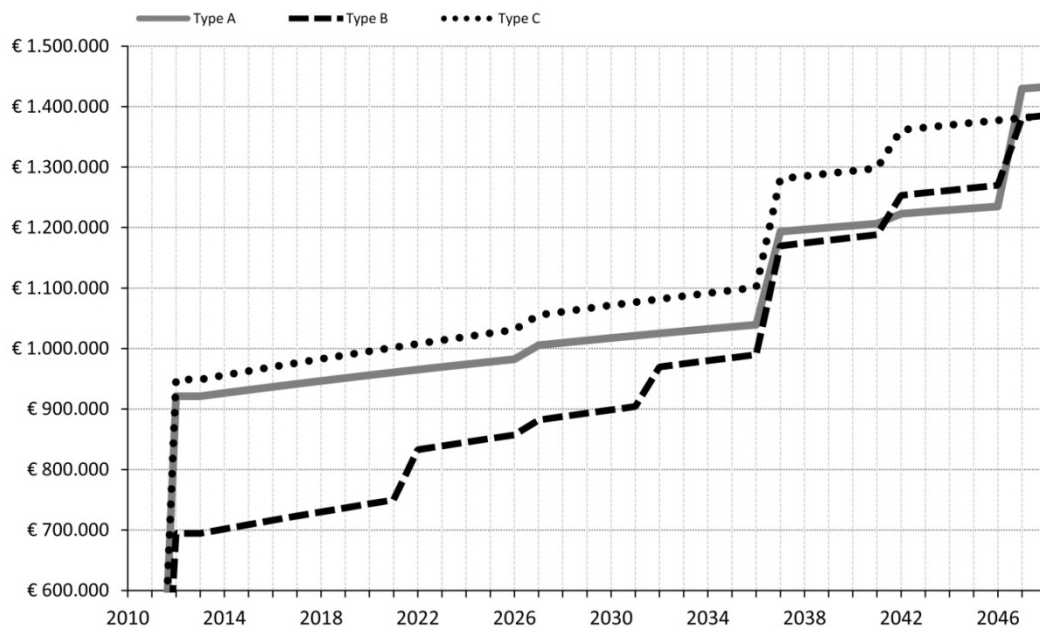

Figure 13. Life cycle costs of three façade types over thirty-six years of operation
 Financial input: start of construction: 2012; Start of building operation: 2014; Period under review: 36 years;
 Discount rate: 5.0%; Inflation: 2.5%; Advance of energy prices: 4.0%; Advance of labour costs: 3.0%
 Price Sources: Austrian engineer companies, prices discounted to the year 2011

Slika 13. Troškovi vijeka trajanja tri tipa pročelja u razdoblju od trideset i šest godina
 Ulazni financijski podaci: Početak gradnje: 2012; Početak korištenja zgrade: 2014; Razmatrano razdoblje: 36 godina;
 Diskontna stopa: 5.0%; Inflacija: 2.5%; Predujam na cijenu energije: 4.0%; Predujam troškova rada: 3.0%
 Izvor cijena: Austrijske inženjerske tvrtke, cijene diskontiraju do 2011

While the differences of initial investment costs range up to 27%, after thirty-six years of operation the total costs of construction, operation, cleaning, maintenance and renewal hardly differ anymore. The reason for this is shown in Figure 13. While façade type A and C are initially more expensive, after 36 years type B turns out to be as expensive as the other two by using components with a shorter life cycle as well as devices that need more maintenance (e.g. blinds, electric windows) and cleaning effort (e.g. metal coating).

8. Conclusions

This paper presented preliminary results regarding an integrated simulation approach within the ongoing research project INFO. The project background, scope and challenges were discussed.

Preliminary measurement results of heat-emissions from machines and observations of production processes showed high fluctuations during the day, ranging from 90 to 200 kW within the analysed production facility. As a partial contribution, the impact of different design and operational options (e.g. façade types, window areas, ventilation rates, lighting and shading control) on the indoor climate and energy performance of an industrial facility was specifically explored. Based on

As research has shown [34][35], the results of life-cycle costing is highly sensitive to the chosen discount rate as well as the period under review. The higher the discount rate is, the lower is the impact of future events. The results of these life cycle costs are not to be seen as absolute values or prediction. Benefiting from its relative analysis of alternatives they give a good evaluation of how individual façade systems can economically vary over time in relation to each other [36].

these illustrative simulation results, it can be said that high heat-emission rates of machines during the production processes result in space overheating in the summer period. Thereby, conduction gains and losses through the building envelope play a secondary role. The presented results underline the importance of effective operation regimes (for lighting, shading, and ventilation system) toward reducing the building's cooling and lighting demand.

Life cycle costing methodology combined with thermal simulation proves to be an important tool for decision making throughout planning process. It enables the discussion on effective energy-efficiency measurements

already in the early planning phases and prevents the implementation of costly, but inefficient constructions. On the other hand, through evaluation of alternatives the best performing-design in the long-term view can be identified. The precondition for implementation and appreciation of such methods is the paradigm-change from the still mostly short-term ROI (Return of Investment) focused planning towards more long-term oriented strategies for achievement of sustainability in the industrial sector.

Currently different HVAC system components and solutions will be integrated in the simulation process, to identify those which most suitably address high internal gains and characteristic envelope features of industrial facilities.

The next steps involve the coupling of all sub-models including the thermal performance sub-model (modelled in the EnergyPlus application), an energy supply- and heating system model realized in Dymola [37], and a production machinery model (generated in Matlab). Thereby, the BCVTB environment [38] is being utilized for data exchange between the sub-models. The experiences made in this process will be used in further steps toward a fully coupled simulation and analysis environment for the comprehensive (multi-aspect) evaluation of industrial production facilities. As the final outcome of the project, an integrated simulation will be compiled, balancing the energy-costs based on thermal simulations of machines and building with life-cycle costs and benefits on the corporate level. Finally, a guideline for the design of energy-efficient industrial facilities together with a model for an energy-certificate for industrial buildings will be developed.

Acknowledgments

The research presented in this paper is supported in part by funds from FFG (Neue Energien 2020: "Interdisziplinäre Forschung zur Energieoptimierung in Fertigungsbetrieben"). The authors further acknowledge the developmental and organizational contribution by Christoph Dorn, Lars Oberwinter, Ines Leobner, and Georg Neugschwandtner toward conducting the present research.

REFERENCES

- [1] *Official Journal of the European Union*, DIRECTIVE 2010/31/EU OF THE EUROPEAN PARLIAMENT AND OF THE COUNCIL of 19 May 2010 on the energy performance of buildings, 2010.
- [2] *Energy Agency*, <http://www.energyagency.at/fakten-service/energie-in-zahlen/endenergieverbrauch.html>, last accessed October 2012.
- [3] *Umweltbundesamt*, <http://www.umweltbundesamt-daten-zurumwelt.de/umweltdaten/public/theme.do;jsessionid=933776E5739692F5A2EC25AB1A7570AD?nodeIdent=5978>, last accessed October 2012
- [4] *EU Climate Policy*, http://ec.europa.eu/clima/policies/package/index_en.htm, last accessed October 2012.
- [5] CONOLLY D., LUND H., MATHIESEN B.V., LEAHY M.: A review of computer tools for analysing the integration of renewable energy into various energy system., *Applied Energy* Vol. 87 (2010) 1059–1082.
- [6] GONG M: *Optimization of industrial energy systems by incorporating feedback loops into the MIND method*. *Energy*, Vol. 28 (2003): 1655–1669.
- [7] MARDAN N., KLAHR R.: *Combining optimisation and simulation in an energy systems analysis of a Swedish iron foundry*, *Energy* (2012) Vol 44: 410-419.
- [8] ZHANG B.J., HUA B.: *Effective MILP model for oil refinery-wide production planning and better energy utilization*. *Journal of Cleaner Production* Vol. 15 (2007): 439 – 448.
- [9] KONG H., QI E., HE S., LI G.: *MILP Model for Plant-Wide Optimal By-product Gas Scheduling*. *Iron and Steel Industry*. *International Journal of Iron and Steel Research*, Vol. 17(7) (2010) : 34-37.
- [10] SOYLU A., ORUC C., TURKAY M. , FUJITA K., ASAKURA T.: *Synergy analysis of collaborative supply chain management in energy systems using multi-period MILP*. *European Journal of Operational Research* Vol.174 (2006): 387–403.
- [11] GOGG T.J., MOTT J.R.: *Introduction to Simulation*, In: Evans et al (Ed): *Proceedings of the 1993 Winter Simulation Conference*, 1993
- [12] KLINGSTAM P, GULLANDER P.: *Overview of simulation tools for computer aided production engineering*, *Computers in Industry*, Vol 38 (1999): 173–186.
- [13] Smith R. *State of the art in process integration*. *Applied Thermal Engineering* Vol. 20:1337-1345, 2000
- [14] AGHA M.H., THERY R. , HETREUX G. , HAIT A., Le LANN J.M.: *Integrated production and utility system approach for optimizing industrial unit operations*, *Energy* Vol. 35 (2010): 611–627.
- [15] IFU - Institut für Fabrikbetriebslehre und Unternehmensforschung, *Schlussbericht Planungsleitfaden Zukunft Industriebau*, Forschung an der Technischen Universität Braunschweig, Technische Universität Braunschweig, , 2010
- [16] American Society of Heating, Refrigeration and Air-Conditioning Engineers: *Advanced Energy Design Guide for Small Warehouses and Self-Storage Buildings*, The American Institute of Architects, 2008
- [17] SALMINEN V., KALIKOSKI P.: *Challenges of Industrial Service Business Development*, *Service Science: Research and Innovations in the Service Economy*, 2008
- [18] NYLUND H., TOIVONEN V., SALMINEN K., TUOKKO R.: *CSM-Hotel – A new Manufacturing Concept for Small and Medium Enterprises*, 44th CIRP

- Conference on Manufacturing Systems*, Madison, WI, USA, May 31 – June 3, 2011.
- [19] PARDO MARTINEZ C.: *Energy efficiency development in the German and Colombian textile industry*, Energy for Sustainable Development. Vol. 14 (2010): 94-103
- [20] *Eco2cut*: <http://eco2cut.com/>, last accessed September 2012.
- [21] SCHÖPFBERGER W.: *Abschaltbare Fabrik Zentrale Leittechnik und Gesamtkonzept zu Energieeinsparungen und zur Ressourcenoptimierung im Standby Betrieb von Industrieanlagen*, Berichte aus Energie- und Umweltforschung 72, 2010.
- [22] ALHOURANI F., SAXENA U.: *Factors affecting the implementation rates of energy and productivity recommendations in small and medium sized companies*, Journal of Manufacturing Systems Vol. 28 (2009): 41-45.
- [23] BUNSE K., VODICKA M., SCHÖNSELEBEN P., BRÜLHART M., ERNST F.O.: *Integrating energy efficiency performance in production management – gap analysis between industrial needs and scientific literature*, Journal of Cleaner Production Vol. 19(2011): 667-679.
- [24] REKOLA M. et al: *Towards Integrated Design and Delivery Solution: Pinpointed Challenges of Process Change*, Architectural Engineering and Design Management, Vol. 6 (2010): 264-278.
- [25] HOPPE S.: *An experimental and numerical analysis of chip formation in metal cutting*, RWTH, 2003.
- [26] TÖNSHOFF H.K.: *Spanen*, Springer Verlag, Berlin, 2003.
- [27] MÜLLER B.: *Thermische Analyse des Zerspanens metallischer Werkstoffe bei hohen Schnittgeschwindigkeiten*, Aachen 2004
- [28] KORDONOWY D.N.: *A power assessment of machine tools*, MIT, 2002.
- [29] GUTOWSKI T.G., *Electrical Energy Requirements for Manufacturing Processes*, 13. CIRP, Leuven 2006.
- [30] MCGRAW HILL CONSTRUCTION.: *The Business Value of BIM in Europe*, McGraw-Hill Construction, 2010.
- [31] *Meteonorm 2012, Global Meteorological Database*, Version 6.1. www.meteonorm.com, last accessed September 2012.
- [32] *Energyplus 2012, Energy Simulation software*, <http://apps1.eere.energy.gov/buildings/energyplus/>, last accessed September 2012.
- [33] BERK, J., DeMARZO, P.: *Corporate Finance*, second edn, Pearson, 2007.
- [34] ELLINGHAM I., FAWCETT W., *New Generation Whole-Life Costing*, Taylor&Francis, 270 Madison Avenue, New York, USA, 2006.
- [35] HERZOG K., *Lebenszykluskosten von Baukonstruktionen*, PhD Thesis, 1. Auflage, Darmstadt, Eigenverlag, Heft 10, 2005.
- [36] WALTENBERGER L., *LCC und LCA von Fassadensystemen im Industriebau*, Masterthesis, TU Wien, 2011.
- [37] Dymola 2012, *Multi-Engineering Modeling and Simulation*, <http://www.3ds.com/products/catia/portfolio/dymola>, last accessed September 2012.
- [38] BCVTB 2012, *Building control virtual test bed*, <http://simulationresearch.lbl.gov/projects/bcvtb>, last accessed September 20