

CODEN STJSAO
ZX470/1597ISSN 0562-1887
UDK 621.432-027.512:536.7

Developments for future implementation in Dish-Stirling technology*

Carlos MONNÉ, Yolanda BRAVO,
Sergio ALONSO, Francisco MORENO,
Mariano MUÑOZ

Department of Mechanical Engineering,
University of Zaragoza, C/María de Luna s/n,
50018 Zaragoza,
Spain

cmmmb@unizar.es
ybravo@unizar.es
sealonso@unizar.es
fmoreno@unizar.es
mmunoz@unizar.es

Keywords

Dish Stirling
Hybridization
Thermal storage
Solar energy

Ključne riječi

Stirlingov sunčev tanjur
Hibridizacija
Skladištenje topline
Solarna energija

Primljeno (Received): 2012-02-21
Prihvaćeno (Accepted): 2012-05-30

1. Introduction

The electric energy generation, coming from a variety of sources: thermal (from fossil fuels), hydraulic, nuclear and renewable, entails one of the highest consumption of fossil fuels and emissions generation. Nowadays the thermal sources are the most used for this electricity production in most of the countries. As an example, in the USA, country with the highest electricity consumption that represents a percentage of 25% of the world, the electricity generation produces the highest emissions percentage, 40% [1]. What is more, concerning the evolution of energy sources at world level, the expectations from 2005 to 2030 show a significant increase in electricity consumption with a

Subject review

Abstract: The dish-Stirling technology for power generation, using a Stirling engine fed with a renewable energy such as solar, means a promising development regarding electricity generation. The dish-Stirling technology presents the highest efficiency, around 30%, in relation to other solar energy generation systems. However the technology status has not achieved enough advancement to be competitive with other renewable energy technologies. A state-of-the art review has been carried out in order to identify the developments needed to guarantee the feasibility of using the dish-Stirling technology. These are, on the one hand the system hybridization, in such a way that guarantees continuous operation, implying amortization improvement and on the other hand the thermal storage, providing system operation with stored energy during some periods such as transients. In this paper, a complete review of literature concerning the state-of-the-art and developments of dish-Stirling technology has been carried out, presenting the most outstanding issues considered for future implementation.

*Razvoj tehnologije Stirling sunčevog tanjura za buduću primjenu

Pregledni rad

Sažetak: Tehnologija Stirling sunčevog tanjura za proizvodnju električne energije, koristeći Stirling-ov motor napajan iz obnovljivog izvora energije kao što je sunce, predstavlja obećavajući razvoj u pogledu proizvodnje električne energije. S učinkovitošću od oko 30% tehnologija Stirling sunčevog tanjura jest najučinkovitiji solarni sustav za proizvodnju električne energije. Međutim, sadašnji napredak tehnologije nije dovoljan kako bi se postigla konkurentnost s drugim obnovljivim izvorima energije. Pregled trenutnog stanja tehnologije je proveden kako bi se utvrdio potreban razvoj koji bi jamčio izvedivost korištenja tehnologije Stirling sunčevog tanjura. To su, s jedne strane sustav hibridizacije, osiguravanje njegovog kontinuiranog rada, poboljšanje amortizacije te s druge strane skladištenje topline, pod uvjetom osiguranja rada sustava u prijelaznim razdobljima sa skladištenom energijom. U ovom radu proveden je kompletan pregled literature o trenutnom stanju i razvoju tehnologije Stirling sunčevog tanjura, te navodi najistaknutija pitanja za njihovu buduću primjenu.

significant weight of non-renewable sources, such as coal and natural gas.

In this context, the use of renewable energy must be promoted, and so must research and development on them. Currently the use of renewable energy has entailed the development of a variety of technologies, optimizing durability and cost issues, in such a way that some of them have achieved an acceptable level in comparison with conventional fossil fuel technologies. It must also be taken into account the environmental evaluation, in such a way that the use of renewable energies is supported, and the proper economic incentives can be applied. In any case, the final objective should be that the renewable energies are

really competitive in themselves, without the need of the incentives coming from the government support.

The environmental impact should be the starting point to select or give priority to one or other energy source. In this sense, several studies have been carried out, comparing conventional (fossil and nuclear) and renewable energies [2, 3]. One of the criteria for environmental evaluation is CO₂ emission per kWh of produced energy. This value is favourable to renewable energies when it is compared with fossil fuels. The nuclear energy shows also adequate values, though other issues must be taken into account regarding this energy source, such as security and waste treatment. Regarding renewable energies, the evaluation is, in decreasing order, the wind energy, hydraulic and solar thermal, followed by biomass and, at last, solar photovoltaic. Thus, it is shown that the solar thermal energy should be prioritized in relation to solar photovoltaic for locations where sun energy has a high potential for use. These areas, as shown in figure 1, correspond to solar irradiation values around 200 W/m².

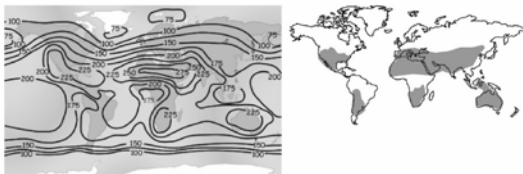

Figure 1. Solar irradiation. Mean value (W/m²) and potential areas for solar applications [3].

Slika 1. Sunčevo zračenje. Srednja vrijednost (W/m²) i potencijalna područja primjene solarnih tehnologija [3].

The solar thermal technologies are: central receiver, parabolic trough and dish-Stirling. The two first technologies are suitable for a high electricity production value, whereas dish-Stirling technology enables distributed generation with units varying from 7 to 25 kW. Basically, a dish-Stirling unit consists of a dish receiver to collect and direct the sun rays in such a way that the concentrated sun energy is transferred to the fluid inside a Stirling engine. This engine is the responsible for producing the power that will be converted to electricity by means of a converter. The unit is supported by a metallic structure, placed on a concrete settlement to provide stability. The stability of the dish-Stirling unit is a significant issue, since the system has a tracking system to follow the sun rays guaranteeing the proper shape and position of the concentrated sun energy. The dish-Stirling technology presents the advantages of modularity, with possible applications varying from isolated facilities for distributed energy to big facilities with the aggregation of a high number of dish-Stirling units.

Several technical reports have been identified pointing out the potential role of dish-Stirling technology.

Romero [4] determines that the dish-Stirling systems are, without any doubt, the technologies with the highest potential in the long term, due to its high efficiency and modularity, being especially attractive from the point of view of planning and funding. It also points out that it is completely necessary an industrial strategy regarding exports to a wide market in order to guarantee feasibility. Besides, this technology could have an outstanding role as for distributed energy [5]. CIEMAT [6] determines that the achievements attained so far foresee electricity generation costs lower than 0,12-0,17 €/kWh in the short term. However, in spite of the high potential due to efficiency and modularity, the limitation of unit power (in any case lower than 25 kW) can avoid the use in applications for big scale production. Thus, the clearest application is the distributed generation for electricity production in isolated places where electric net is not available, where the dish-Stirling technology can be competitive with current commercial systems, such as photovoltaic or diesel generation.

The SBP company, working in the development of the dish-Stirling technology, establishes future costs around 0,08 €/kWh [7], that agree with objective values around 0,06 €/kWh of energy prices fixed by DOE (Department of Energy) of USA [8] for 2011. It must also be taken into account that renewable sources mean an alternative in the long term for conventional fuels that could have an important cost increase due to resources depletion, together with politic issues for energetic independence. In particular, dish-Stirling energy could be compared with photovoltaic energy since it means the alternative facility for similar applications. The current price for photovoltaic energy is around 0,3 €/kWh [9], though this value depends highly on facility size and type. Besides, the development of new technologies can further reduce this value in the short term, in such a way that the photovoltaic energy could be competitive without the need of government funds in year 2015. The future comparison of photovoltaics with dish-Stirling is yet under uncertainty, and development issues will be determinant to favour one or the other technology. Last but no least, the environmental evaluation of the dish-Stirling technology must be considered. It is necessary to provide a comparative environmental assessment of dish-Stirling technology with respect to a similar facility using the Life Cycle Assessment procedure. Comparing the dish-Stirling technology respect to the photovoltaic technology [10] and analyzing the results in terms of CO₂ emissions, it has been obtained that the level of environmental impact is similar for both technologies.

2. State of the art

The dish-Stirling system is, as mentioned before, one of the solar thermal technologies for power generation. In this system, the sun rays provide the energy that makes the Stirling engine works. The sun rays are collected in

a reflecting surface, the dish with paraboloidal shape made in one or several parts. The dish moves along the day in order to follow the sun trajectory. The tracking system is one of the key elements in the dish-Stirling technology. Figure 2 shows one unit of this technology of the company SES (Stirling Energy Systems).



Figure 2. Dish-Stirling system. SES (Stirling Energy Systems) prototype .

Slika 2. Prototip sustava Stirling sunčevog tanjura SES (Stirling energetske sustav)

The sun energy is converted into thermal energy by means of heat exchange with the work fluid inside the Stirling engine. The sun rays that are collected in the dish are directed to a focal point inside a ceramic cavity. The radiation distribution impinges on a surface of approximately 30*30 cm [11]. The heat exchanger is placed in this surface, in such a way that the working fluid inside receives the corresponding energy. This energy enables to achieve the high temperature proper for the operation of the Stirling engine

The dish-Stirling technology has been used in several research and development projects with a number of demonstration facilities supported by different companies and research bodies around the world [12, 13].

Table 1. Specifications and operation parameters of several dish-Stirling systems [3].

Tablica 1. Tehničke značajke i radni parametri nekoliko sustava Stirling sunčevih tanjura [3].

Concentrator/Prijemnik	SAIC/STM	SBP	SES	WGA(mod1)	WGA(mod2)
Type/Vrsta	Approximate /Približno	Paraboloid/Paraboloid	Approximate /Približno	Paraboloid/Paraboloid	Paraboloid/Paraboloid
Proj. Area/ Proj. površina (m ²)	113,5	56,7	87,7	41,2	41,2
Reflectivity/Reflektivnost (m ²)	0,95	0,94	0,91	0,94	0,94
Height/Visina (m)	15	10,1	11,9	8,8	8,8
Width/Širina (m)	14,8	10,4	11,3	8,8	8,8
Weight/Težina (kg)	8172	3980	6760	2864	2481
Focal length/Duljina žarišta (m)	12	4,5	7,45	5,45	5,45
Intercept factor/Osni faktor	0,9	0,93	0,97	0,99	0,99
Peak CR/Vršni CR (suns)	2500	12730	7500	11000	13000
Power Conv. Unit/Jedinica pretvorbe energije	SAIC/STM	SBP	SES	WGA(mod1)	WGA(mod2)
Aperture Dia./Promjer otvora (cm)	38	15	20	14	14
Engine/Motor	STM 4-120	SOLO 161	SES 4-95	SOLO 161	SOLO 161
Cylinders/Cilindri	4	2	4	2	2
Displacement/Pomak (cc)	480	160	380	160	160
Speed/Brzina (rpm)	2200	1500	1800	1800	800-1890
Working fluid/Radni fluid	Hydrogen/Vodik	Helium/Helij	Hydrogen/Vodik	Hydrogen/Vodik	Hydrogen/Vodik
System Information/Informacije o sustavu	SAIC/STM	SBP	SES	WGA(mod1)	WGA(mod2)
Systems built/Izgrađeni sustavi	5	11	5	1	1
On-sun op/Operacijski sati (hrs)	6360	40000	25050	4000	400
Peak Output/Vršna snaga (kW)	22,9	8,5	25,3	11	8
Peak effic. Net/ Vršna učinkovitost	20	19	29,4	24,5	22,5

As for main development projects for commercialization of dish-Stirling systems, the information is collected in table 1. Different technical data are summarized in this table (information from February 2002 [13]). The table includes the development projects carried out by SBP and SES that have resulted in current commercial equipment. Regarding the project leaded by SAIC (Science Applications International Corp.) and STM Power Inc., and the one coordinated inside the Cummins Dish-Stirling Joint Venture Program by associated members of the project WGA, both carried out in the United States, there is no information related to later commercialization. The Infinia system is not included, since no full data are available (some data: power 3 kW, weight 864 kg, maximum height 6,4 m and diameter 4,7 m [14]).

The first big scale application is currently under construction in the USA. SES (Stirling Energy Systems) company is constructing two plants in California [11] that will provide a power of 1600 MW from 2011 with the SunCatcher™ technology. Tessera Solar [11], company associated to SES, is in charge of big scale applications of dish-Stirling technology, with the two plants mentioned before, in collaboration with San Diego Gas & Electric and Southern California Edison. The projects for these two plants are: Imperial Valley (750 MW – 30000 SunCatcher™) and Calico (850 MW – 34000 SunCatcher™), a total of 6400 dish-Stirling systems with a unit power of 25 kW. Other smaller facilities are: Western Ranch, in Texas, with the company CPS Energy (27 MW – 1080 SunCatcher™) and Maricopa Solar, in Arizona, with the company Salt River Project (1,5 MW – 60 SunCatcher™). Both were initiated in 2009, and the start of operation is foreseen by 2011.

Other companies such as Infinia [14] in the USA, and SBP [7] in Germany, are also leaders in the developments of dish-Stirling systems. Infinia is an organization that works on the development of Stirling engines. The dish-Stirling technology units of 3 kW (PowerDish™), are included in their technological offer both for distributed generation or big scale facilities. Renovalia Energy [15] has signed an agreement with Infinia, and has imported the dish-Stirling technology to Spain for power generation. This company is a Spanish company that produces electricity from a variety of renewable energy sources, including thermosolar. The first plant with Infinia technology is Casa del Ángel Termosolar, located at Casa de los Pinos, Cuenca (Spain), with 0,99 MW power. The following project is a 71 MW power plant and is located at Villarobledo, in Albacete (Spain) [16], currently in development phase.

SBP is a German company that has participated in the European project EURODISH (1998-2001) and

ENVIRODISH (2002-2005), for the development and demonstration of dish-Stirling technology, together with other European companies and research institutions. These projects have worked on demonstration facilities in different European countries, such as Germany, Italy, France and Spain (Plataforma Solar de Almería – PSA- and Sevilla University) [17].

3. Future developments

The use of dish-Stirling technology as a feasible technology for commercial applications depends significantly on the steps of development from now on. One of the key issues is the cost of energy provided by this technology. In this sense, it is crucial to ensure the operation of the facility the longer time possible. Since the operation of any solar technology depends on sun irradiation, the two main developments are focused on overcoming the limitation of this irradiation that depends on climatic conditions. On the one hand, the use of other energy sources in combination with solar energy, so they can be used alternatively depending on climatic conditions. Thus, the system should be hybridized in order to enable the use of the equipments with different energy sources. It is especially interesting that the alternative energy sources are renewable, so the dish-Stirling unit works with less environmental impact. On the other hand, if the sun energy could be stored so it could be used in times where it is not available or when the sun irradiation does not reach the nominal operation value of the system, it would also mean a great advantage. These two developments: hybridization and thermal storage would mean improvement regarding amortization of equipments, and also regarding transient operation. It is also expected that they would decrease environmental impact, though this issue must be analysed with the proper procedures.

3.1. Hybridization

The hybridization is the use of several energy sources in a facility. The advantages are: adaptation of production to electricity demand (flexibility), stability of production in transient period, management improvement, increase of the use of equipment (amortization) and start-up support. The hybridization is part of general energy strategies [18], and is used in several power generation technologies. The first application comes from the 80's, when the DOE (Department Of Energy) of the United States, promoted a programme for hybridization of fossil fuel plants with central receiver systems [19]. Nowadays the development of thermo-solar plant has inverted the hybridization, and the combustion system supports the solar plant. The most important thermo-solar plants, with central receiver and parabolic trough technologies, are planified using hybridization with natural gas or biomass. In particular, several hybrid parabolic trough

plants will be in operation in the following years [20], and there are several projects for central receiver plants (Solgate, SolHyCo, Solugar [21], Sirec [17]).

Hybridization is significantly interesting when it is applied with two (or more) renewable energies, regarding resources consumption and pollutant emissions. The environmental impact of hybridization has been evaluated for different combination of energy sources: wind energy with biomass [22] and wind energy with photovoltaic energy [23]. If the environmental impact of the isolated energy sources is considered, it results specially interesting to apply hybridization of solar energy with biomass, since they are the ones that present low values regarding this indicator. The isolated Stirling engine has been included in hybrid systems, operating as complement of other systems: Otto engine [24], fuel cells [25] and electric cars [26].

As for the dish-Stirling technology, a number of developments have been carried out by different companies and research institutions [13]. The hybridization means an important potential for cost reduction [27] of the technology with the highest efficiency for solar energy power generation. The design of the hybrid receiver, that provides the heat transfer to the Stirling engine from solar or the alternative source, is the key point of the developments, since it is a complex technical issue. There are basically two types of hybrid receivers: Directly Illuminated Receivers (DIR) and Reflux Receivers [28]. In DIR, the sun radiation impinges directly in the surface where the Stirling working fluid is confined, normally tubes forming the heat exchanger. In the Reflux Receivers, there is an intermediate working fluid, mainly sodium and/or potassium compounds, that transfers heat from the energy source to the Stirling fluid, according to the operation principle of heat pipes. The latter means a more complex development, but presents advantages regarding durability and efficiency in relation to DIR. The main drawback of DIR comes from the lack of uniformity of temperature in the surface that causes mechanical stress to material.

The hybridization projects for dish-Stirling technology were initiated in 1981 and have been developed for both types of receivers. As there are already a number of technical articles regarding the description of these receivers [28], in the present article only the most recent (since 1995) and important developments are mentioned

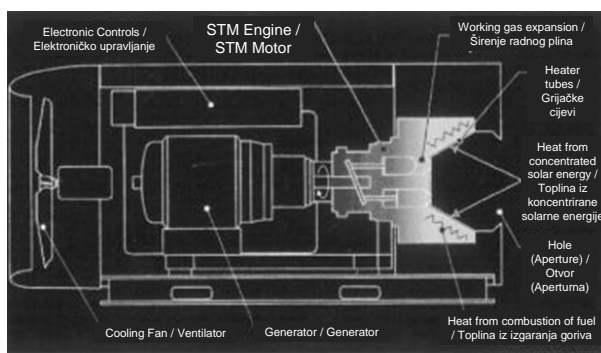

and briefly introduced. These are: for DIR, SAIC/STM Sundish System (1999-2000) [29] and Biodish (2000-2003) [13], and for Reflux Receivers, HYPHIRE (1997-2000) [30, 31] and Sandia project (1995-2002) [32].

- SAIC/STM Sundish System (DIR): installation of a dish-Stirling unit in a landfill for exploitation of biogas, with a time of operation of 600 hours. The main problem found was the fouling due to the biogas composition and the lack of continuity of this composition. A filter and a continuous monitoring of the composition was necessary to adapt combustion characteristics. The receiver consists of a bundle of thin parallel tubes, located in a truncated cone, as it is shown in figure 3.

Figure 3. System SAIC/STM Sundish [29].

Slika 3. Sustav SAIC / STM Sundish [29].

- Biodish (DIR): ceramic cylinder-shape receiver (figure 4) that absorbs sun radiation in the inner face and combustion energy in the outer surface, alternatively or at the same time. The combustion burner is swirl type. The ceramic material is silicon carbide (SiC) reinforced with carbon fibre to withstand the high internal pressure (up to 150 bar). The main drawback of this receiver is the complex production and the high cost. This project also performed an economic analysis for feasibility of a plant with 50 to 100 dish-Stirling units hybridized with gasified biomass.



Figure 4. Biodish receiver[13].

Slika 4. Biodish prijammnik [13].

- HYPHIRE (reflux receiver): heat pipe receiver of sodium, with a working temperature between 700 and 850 °C. It consists of three heat exchange surfaces: inner surface for receiving the sun energy, outer finned surface for gas combustion and heat output to the Stirling engine. The system can operate isolated or simultaneously with both energy sources. It has been tested during 117 hours in sun mode, 92 hours in combustion mode and 56 hours in simultaneous mode in PSA (Plataforma Solar de Almería). A photograph is shown in figure 5.

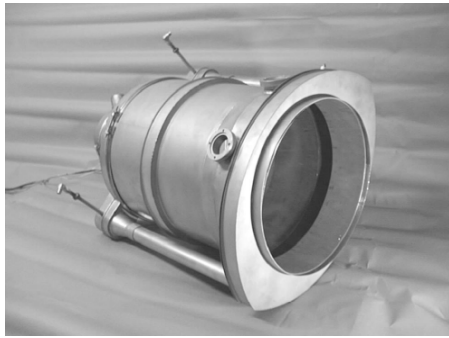

Figure 5. HYPHIRE receiver [30].

Slika 5. HYPHIRE prijammnik [30].

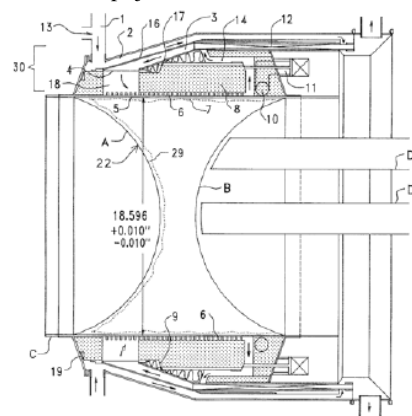

Figure 6. Sandia receiver [32].

Slika 6. Sandia prijammnik [32].

- Sandia (reflux receiver): heat pipe receiver of sodium, with a working temperature around 750 °C. The combustion system is provided with a metallic matrix burner, operating in radiant mode. The

Table 2. Burner types in function of combustion characteristics.

Tablica 2. Tipovi gorionika u funkciji karakteristika izgaranja.

	Burner type/Tip gorionika		Other aspects/Ostali aspekti
Pressure supply/Oprskrba tlaka	Atmospheric/Atmosferski	Supercharged/Super punjenje	Supercharging improves combustion efficiency/Super punjenje poboljšava učinkovitost
Mixture oxidant-fuel/Smjesa oksidansa-goriva	Mixture in combustion chamber/Smjesa u komori izgaranja	Mixture before entering combustion chamber/Miješanje prije ulaska u komoru izgaranja	Premix burner improves combustion process/Gorionik s predmješanjem poboljšava izgaranje
Combustion type/Vrsta izgaranja	Difussion flame/Difuzijski plamen	Radiant/Radijacijsko	Radiation is similar to sun energy/Radijacija slična sunčevoj energiji More complex design/Kompleksna izvedba

Table 3. Combustion characteristics in relation to fuel type.

Tablica 3. Karakteristike izgaranja u odnosu na vrstu goriva.

exchange surface with combustion gases is provided with fins to enhance the heat transfer, as shown in figure 6.

An important issue for the design of the hybrid system is the burner selection. It can be determinant for the design of other components, such as the receiver, since it collects the energy released by this burner. The burners are classified according to different criteria [33]. The classification in relation to combustion characteristics is presented in table 2. The pressure supply determines if the burner is atmospheric or supercharged. The time when the mixture between oxidant and fuel is done, determines if it is a premix burner. If the combustion takes place very nearly to burner surface without diffusion flame, the burner is called radiant. Thus, the combustion energy is released by radiation caused by the high temperature of the material.

The fuel type must be also taken into account. It determines if the burner is considered as gas, liquid or solid burner. The gaseous state of the fuel improves the mixture with the oxidant, thus improving the combustion regarding energy release and emissions level. In the case of liquid state, the fuel must be vaporized before combustion, thus adding complexity to the system. As for solid fuels, the complete combustion highly depends on the aggregation level and the status of the solid. The fouling is also more critical for solid fuels, followed by liquids. The advantages and drawbacks are presented in table 3 regarding the use of biomass as a combustion source for dish-Stirling technology.

Fuel type/Vrsta goriva	Advantages/Prednosti	Drawbacks/Nedostaci
Gas/Plinovito	Good combustion characteristics/Dobra svojstva izgaranja	Availability of biogas/Dostupnost bioplina
Liquid/Tekuće	Good combustion characteristics if vaporized/Dobra svojstva izgaranja ako je ispareno	Vaporization process needed/Proces isparavanja nužan Fouling/Onečišćenje
Solid/Kruto	Availability of biomass in solid state/Dostupnost biomase u krutom stanju	Low combustion efficiency/Izgaranje niske učinkovitosti Critical fouling/Zašljakanje

Regarding the burner geometry, it can be basically rectangular or round-shaped. The latter is preferred due to production considerations and elimination of corners that can represent failure points of the burner. In another geometrical position, the burner can be located concentrically to combustion source. The burner shape determines also the fluid movement. Thus, a turbulent flow can be imposed (swirl flow) in comparison to laminar flow. The level of turbulence has an influence also on combustion conditions. There are low turbulent burners with specific flame characteristics specially designed to operate with poor mixture with high efficiency and low emissions [34]. Regarding the material, the burner can be metallic or ceramic. Depending on the material selection, the burner can withstand the high combustion temperature with both type of material. The ceramic burner has a better mechanical stability, though its drawback is fragility.

3.2. Thermal storage

The use of thermal storage enables to store energy when this is not necessary for operation, in such a way that it is available in the appropriate time, transient times, start-up or when the main source energy is not available (in the case of solar energy, in cloudy days or during night). The thermal storage is performed with Phase Change Materials (PCM). The thermal storage system associated to a dish-Stirling system could be installed as an isolated system, or integrated with a reflux receiver in case this technology is used in the system. For both cases, the management of the system is a key issue so it regulates the periods of energy storage and release.

As for potential fluids, there are experiences for Stirling engine in lithium fluoride [35, 36] and magnesium hidrades [37]. As for known systems, in the 2009 Clean Technology congress [38] a low-temperature Stirling engine –SolarHeart™ Engine– was presented for conversion of hot sources around 100-300°C, including thermal solar, geothermal and industrial waste flow. The facility integrated sun roof collectors (SolarFlow™ System) with a tank for thermal storage, including also an advanced control system to optimize the generated or stored energy for power supply.

For PCM selection, the key factors are nominal temperature, that in the case of dish-Stirling engine is high (around 500-900 °C), and thermal capacity. There

are also other factors: cost-benefit balance, and technical and environmental criteria. The cost depends on the PCM itself and also on the heat exchanger needed for charge and release of the system. As for technical aspects: high energetic density, good heat transfer coefficient (efficiency), mechanical and chemical stability (to withstand charge and discharge cycles), compatibility with other materials, reversibility of charge and discharge cycles (hysteresis), low thermal losses and easy control management. The high temperature thermal storage systems in solar thermal plants are classified in active or passive systems. In the active systems, the thermal exchange is produced by forced convection with the material circulating by a heat exchanger. In the passive systems, there is another heat transfer fluid that passes by the PCM tank, for thermal charge and discharge.

A classification of potential PCM [39] to use in dish-Stirling technology is presented in table 4.

Regarding dish-Stirling technology, it is known that Stirling Energy Systems (SES) and Infinia are working on the integration of thermal storage systems. In particular, Infinia has started a project supported by the DOE, where 40-50 systems will be used for demonstration in Sandia facilities. As a result of the research, Infinia presented a patent in 2010 (reference WO2010006319) [40], presented in figure 7.

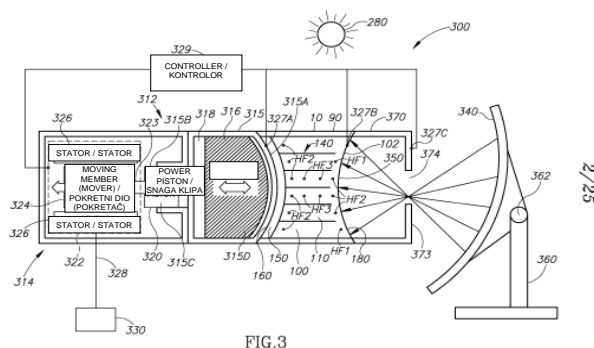

Figure 7. Thermal storage device. Picture from the Infinia's patent [40].

Slika 7. Uređaj za skladištenje topline. Slika iz Infinia patenta [40].

The device for thermal storage presented in this patent consists of a container with the PCM, having an input and output for heat flow. This device is a reflux receiver type, in such a way that the input receives energy from an external source through thermal energy transport members. The energy is transferred to the output and / or the PCM. Other thermal energy transport members will be in charge of transferring energy from the PCM to the output when this energy is required. The output is connected to the Stirling engine. The control system is significantly important to manage heat transfer flows through the operation elements. In this patent, extensive information is presented regarding material selection that must take into account a high phase change temperature together with a high latent heat of fusion. This is the case for eutectic salts, such as LiF/NaF/MgF₂, LiF/NaF y NaF/NaCl, or other material

such as Li, LiOH, LiH, LiF/CaF₂, LiF, NaF, CaF₂ y MgF₂. In this patent, the lithium hidrate (LiH) is presented as one of the most suitable PCM for use in the dish-Stirling technology. LiH has a high specific energy, available in the range of working temperature from 500 to 1000°C. The lithium fluoride (LiF) has also suitable values, with the highest energy density in this range. There are eutectic salts, such as LiF/NaF/MgF₂, with similar values for operation in the dish-Stirling systems. However, LiH and LiF have advantages regarding production and use of the PCM, due to weight and security reasons. The thermal storage system presented in this patent can operate in combination with hybridization in such a way that there are two different input energy sources.

Table 4. Potential PCM for dish-Stirling technology [39].

Tablica 4. Potencijal PCM-a za tehnologiju Stirling tanjura [39].

Compound/Spoj	Fusion Temp/Temp. taljenja (°C)	Phase change energy/Energija fazne promjene (kJ/kg)	Density/Gustoća (kg/m ³)	Specific heat/Specifična toplina (kJ/kgK)	Thermal conductivity/Toplinska vodljivost (W/mK)
AlSi ₁₂	576	560	2700	1,038	160
AlSi ₂₀	585	460	n.a.	n.a.	n.a.
MgCl ₂	714	452	2140	n.a.	n.a.
80.5%LiF 19.5%CaF ₂ eutectic	767	790	2100/2670 /liquid/tekućina	1,97/1,84 /liquid/ tekućina	1,7/5,9 /liquid/ tekućina
NaCl	800 802	492 466,7	2160	n.a.	5
Na ₂ CO ₃ - BaCO ₃ /MgO	500-850	n.a.	2600	n.a.	5
LiF	850	1800 (MJ/m ³)	n.a.	n.a.	n.a.
Na ₂ CO ₃	854	275,7	2533	n.a.	2
KF	857	452	2370	n.a.	n.a.
K ₂ CO ₃	897	235,8	2290	n.a.	n.a.

4. Conclusions

Hybridization is one of the developments that linked to dish-Stirling technology could guarantee a comparative level with other power generation technologies. It improves reliability and flexibility of the system operation, and increases the facility operation time. Besides, if the secondary energy source is a renewable source, such as biogas, the environmental impact could be further optimized. Future works on hybridization should take into account previous works that are

presented in this paper, together with considerations regarding burner definition. Also the use of thermal storage can provide competitiveness to the dish-Stirling technology. The use of stored energy accumulated in the system itself when the energy level exceed the nominal operation value, improves also reliability and flexibility. In this case, a recent patent of one of the leader companies of dish-Stirling technology, Infinia, has been analysed. The current review has enabled to identify developments needed for future implementations of dish-Stirling technology. Thus, there are technical challenges to face to assure real feasibility of this

promising technology. Further efforts are required to result in profitable and reliable systems that can generate power for both distributed generation and grid-connected applications, guaranteeing a continuous operation based on a combination of solar and other renewable sources.

REFERENCES

- [1]. *Report of the International Energy Outlook*. Energy Information Administration (Official Energy Statistics from the U.S. Government) 2008.
- [2]. VARUN, J.; BHAT, I.K. and PRAKASH, R.: *LCA of renewable energy for electricity generation systems*. A review. *Renewable and Sustainable Energy Reviews*, vol 13, 2009, pp. 1067–1073.
- [3]. GENER, A.: *Análisis de la tecnología solar de discos Stirling: diseño y desarrollo de un dispositivo de 25 kW implementando una metodología de decisión en I+D+i*. Escuela Técnica Superior de Ingenieros Industriales. Universidad Politécnica de Madrid. 2008.
- [4]. ROMERO, M.: Director Plataforma Solar Almería-CIEMAT. *Energía solar termoeléctrica*.
- [5]. PANTOJA-LÓPEZ, A.; SÁNCHEZ, L. and PANTOJA-BROCAS, A.: *Avanzar en generación eléctrica distribuida*. Energía (Madrid). 2007.
- [6]. PÉREZ, M.; CUESTA, M.J.; NÚÑEZ, S. and CABRERA J.A.: *Energía solar termoeléctrica*. Techwatch CIEMAT. 2008.
- [7]. Web SBP (Schlaich Bergermann und Partner). www.sbp.de
- [8]. Web EIA – U.S. Energy Information Administration. <http://tonto.eia.doe.gov>.
- [9]. Solar Energy Technologies Program. 2009. pp. 52-53.
- [10]. BRAVO, Y.: *Sistemas de generación tecnología disco-Stirling: revisión de estado del arte y análisis de ciclo de vida*. 6º Workshop de Tecnologías de Climatización y Eficiencia Energética en Edificios. E.T.S.I.Q. Tarragona. 2010.
- [11]. Web Stirling Energy Systems: <http://www.stirlingenergy.com>
- [12]. REINALTER, W.; ULMER, S.; HELLER, P.; RAUCH, T.; GINESTE, J.M.; FERRIERE, A. and NÉPVEU, F.: *Detailed performance analysis of the 10-kW CNRS-PROMES dish/Stirling system*. SolarPACES2006 A7-S7. 2006.
- [13]. MANZINI, T.; HELLER, P.; BUTLER, B.; OSBORN, B.; SCHIEL, W.; GOLDBERG, V.; BUCK, R.; DIVER, R.; ANDRAKA, C. and MORENO, J.: *Dish-Stirling Systems: An Overview of Development and Status*. *Journal of Solar Energy Engineering*, vol 125, Issue 2, 2003, pp. 135.
- [14]. Web Infinia. <http://infiniacorp.com>
- [15]. Web Renovalia Energy. <http://renovaliaenergy.es>
- [16]. Web <http://www.energias-renovables.com/paginas/>
- [17]. CABRERA, J.A.; CUESTA, M.J. and PÉREZ, M.: *Energía solar térmica de concentración. Estado actual actores del sector*. Techwatch CIEMAT. 2006.
- [18]. BURCH, G.D.: *Hybrid Renewable Energy Systems*. U.S. DOE Natural Gas / Renewable Energy Workshops. 2001.
- [19]. *Solar Thermal Repowering*. Sandia National Laboratories & San Francisco Operations Office. 1998.
- [20]. PUERTAS, J.: *Hibridación con gas natural*. Presentation Gas Natural. 2009.
- [21]. *Energía solar termoeléctrica y biomasa: hibridación y apoyo con gas natural*. Socoin / Unión FENOSA. 2010.
- [22]. PÉREZ-NAVARRO, A.; ALFONSO, D.; ÁLVAREZ, C.; IBÁÑEZ, F.; SÁNCHEZ, C. and SEGURA, I.: *Hybrid biomass-wind power plant for reliable energy generation*. *Renewable Energy*. 2010.
- [23]. NEMA, P.; NEMAB, R.K. and RANGNEKAR, S.A.: *Current and future state of art development of hybrid energy system using wind and PV-solar: A review*. *Renewable and Sustainable Energy Reviews*. 2009.
- [24]. CULLEN, B. and MCGOVERN, J.: *Energy system feasibility study of an Otto cycle / Stirling cycle hybrid automotive engine*. Energy. 2010.
- [25]. SÁNCHEZ, D.; CHACARTEGUI, R.; TORRES, M. and SÁNCHEZ, T.: *Stirling based fuel cell hybrid systems: An alternative for molten carbonate fuel cells*. *Journal of Power Sources*. 2009.
- [26]. *Stirling engines for hybrid electric vehicle applications*. Proceedings of the Intersociety Energy Conversion Engineering Conference, v3, p3. 167-3.177. Conversion Technologies – Electrochemical Conversions. 1992.
- [27]. EYER, J. and IANNUCCI, J.: *Market potential for distributed solar dish-stirling power plants operated in solar-only and solar/natural gas hybrid modes*. *Power Engineering Review*. 1999.
- [28]. RAMOS, H.; ORDÓÑEZ, I. and SILVA M.A.: *An overview of hybrid receivers for solar applications*. 2010.
- [29]. MAYETTE, J.B.; DAVENPORT, R.L. and FORRISTALL, R.E.: *The Salt River Project Sundish Dish-Stirling System*. Proceeding of Solar Forum 2001. Solar Energy: The Power to Choose. April 21-25 2001.
- [30]. LAING, D. and REUSCH, M.: *Hybrid sodium heat pipe receiver for dish/Stirling systems – design and test results*. 2001.
- [31]. LAING, D. and PALSSON, M.: *Hybrid dish/Stirling Systems: Combustor and Heat Pipe Receiver Development*. *Journal of Solar Energy Engineering*. 2002.
- [32]. MORENO, J.; RAWLINSON, K.; ANDRAKA, C.; MEHOS, M.; BOHN, M. and COREY, J.: *Dish/stirling hybrid receiver sub-scale tests and full-scale design*. Proc. of the 34th Intersociety Energy Conversion Engineering Conference. 1999.
- [33]. BAUKAL, C.E. *Industrial burners*. Handbook. CRC Press. ISBN 0-8493-1386-4. 2004.
- [34]. CHENG, R.K.; YEGIAN, D.T.; MIYASATO, M.M.; SAMUELSEN, G.S.; BENSON, C.E.; PILLIZZARI, R. and LOFTUS, P.: *Scaling and development of low-swirl burners for low-emission furnaces and boilers*. Proceedings of the Combustion Institute, Volume 28, 2000/pp. 1305-1313.
- [35]. ASSELMANA, G.A.: *Thermal energy storage unit based on lithium fluoride*. *Energy Conversion*. 1975-2003
- [36]. LONDON, A.L.; SHAH, R. and KRAUS, A.D.: *Compact heat exchangers: a festschrift for A.L. London*. 1990.
- [37]. WIERSEA, M.; WERNERA, R. and GROLLB, M.: *Magnesium hydride for thermal energy storage in a small-scale solar-thermal power station*. *Journal of the Less Common Metals*. 2007
- [38]. WEAVER, S.P.: *Solar thermal storage features enhance low temperature heat to electricity conversion Stirling engine*. Clean Technology Conference & Expo 2009.

- [39]. GIL, A.; MEDRANO, M.; MARTORELL, I.; LÁZARO, A.; DOLADO, P.; ZALBA, B. and CABEZA, L.F.: *State of the art on high temperatura termal energy storage for power generation. Concepts, materials and modellization*. Renewable and Sustainable Energy Reviews 2010; 14: 31-55.
- [40]. QIU, S.; WHITE, M.; YARGER, D. and GALBRAITH, R.: *Thermal energy storage device*. Patent WO2010006319. 2010.