

OPTIMIZATION OF THIN-WALLED CONSTRUCTIONS IN CAE SYSTEM ANSYS

Pavel Beño, Dražan Kozak, Pejo Konjatić

Original scientific paper

Solving optimization problems from the standpoint of structural stresses and strains can be carried out scientifically on the example of telescopic jib. It is mainly due to the fact that despite a broad spectrum of the telescopic jib utilization there are no generally valid, scientifically proven and presented theoretical principles for their designing. From the viewpoint of the classification of mechanics, the arm of telescopic jib as a subject of study can be ranked among thin-walled constructions. In fact, it is a case of enclosed thin-walled bars stressed in operation by a combination of bending and torsion moments. Applying the Finite Element Method (FEM) in connection with the CAE system ANSYS, it is possible to design an optimum shape of the cross-section of the telescopic jib arm. Comparing the calculated values of stresses and deformations with the values obtained by experimental measuring, it is possible to evaluate the effectiveness of the optimization process.

Keywords: ANSYS, CAE system, Finite Element Method, optimization, thin-walled constructions

Optimiranje tankostjenih konstrukcija u CAE sustavu ANSYS

Izvorni znanstveni članak

Znanstveni pristup rješavanju problema optimiranja sa stanovišta naprezanja i deformacije u konstrukciji provedeno je u ovom radu na primjeru teleskopske ruke. To je uglavnom zbog činjenice da, unatoč širokom spektru uporabe teleskopskih ruku, ne postoje općenito valjana, znanstveno dokazana i prezentirana teorijska načela za njihovo projektiranje. Sa stajališta mehanike, krak teleskopske ruke, kao predmet istraživanja može se svrstati u tankostjene konstrukcije. U stvari, riječ je o zatvorenom tankostjenom presjeku opterećenom kombinacijom savojnih i torzijskih momenata. Primjenjujući metodu konačnih elemenata (MKE) povezanu s CAE sustavom ANSYS moguće je projektirati optimalan oblik poprečnog presjeka poluge teleskopske ruke. Uspoređujući izračunate vrijednosti naprezanja i deformacije s vrijednostima dobivenim eksperimentalnim mjerenjima, moguće je procijeniti učinkovitost procesa optimiranja.

Ključne riječi: ANSYS, CAE sustav, metoda konačnih elemenata, optimizacija, tankostjene konstrukcije

1 Introduction

The telescopic jib presents a unique design solution through which it is possible to reach a wide range of work positions of the equipment at a high accuracy of the work cycle. Its universal utilisation is just that feature which predetermines it to be used in manipulators, building, earth-moving and agricultural machines. It is mainly due to the fact that a relatively wide assortment of working equipment can be attached to the end of telescopic jib arm. Individual types differ from one another in their structure mainly because they are designed for various operating conditions and different equipment. The individual producers' team of designers use mostly their own know-how which is a subject of patent protection in many cases. The application of the optimization module, which is part of the majority of high-end CAE software, allows designing the construction of technical parameters for so general utilisation as possible.

From the functional point of view the telescopic jib presents a constructional arrangement of components which are called "guiding" in the technical practice. In fact, it is a system in which the movable part is attached to the stationary part and it moves along geometrically precise and predetermined paths. Its main parts are the outside arm, inside arm and the guiding elements. In addition, it includes also other components which ensure e.g. mutual shift of the arms and working equipment. It is also necessary to consider the effect of the axial rotation mechanism, although it is not often part of the telescopic jib subsystem. The thing is that it affects the design and calculation themselves mainly by its dynamic impacts. On the basis of the above mentioned facts, we can state that the force proportions are necessary to be evaluated from

the viewpoint of static load and with the effect of dynamic load. On the one hand, the questions of force proportions can be evaluated within complex loading, but at the same time they can be observed separately, i.e. from the viewpoint of statics or dynamics. The relations concerning particular cases of load are evaluated in two reciprocally perpendicular planes: in the plane of jib stroke (vertical plane) and in the plane of rotating around the vertical axis (horizontal plane).

Within the analysis of loading forces in the vertical plane it is possible to appraise two basic operation modes: when lifting the jib or when backing it to the support plate on which the equipment is placed. In the process of lifting the bearing structure, the jib is loaded by the mass of particular components, by reactions activated in the places of jib locations and by forces of lifting mechanism activity. From the viewpoint of stressing, forces of the greatest impact are those ones arising as a result of external force application on the working equipment which is usually fixed at the end of the extensible arm. If it concerns the using of the telescopic jib when lifting a certain load, then the external loading is mass of the given load. Generally, it is interaction of working equipment and the object of work cycle of the given equipment.

In the case of backing the working equipment to the support on which is placed the equipment, mass of the load does not act. The jib is loaded by pressure force arising as an effect of the mechanism acting and its running in the vertical plane. If it concerns mobile working equipment, the analysis of external loading in a simplified case is reduced to solving of the classic task of balance of moments. In both cases (lifting or holding down), it is assumed that stabilizing moments equal tilting moments (Fig. 1), where N and Q are vertical external

forces at maximum extension (index 1) and retraction (index 0) of the telescopic jib and z is the maximum length of the arm extensions. The distances of the centres of gravity T_1 and T_0 (gravity forces G_1 and G_0) from the tilting point are e_1 and e_0 . The maximal vertical force N and Q acting at the distance l from the tilting point.

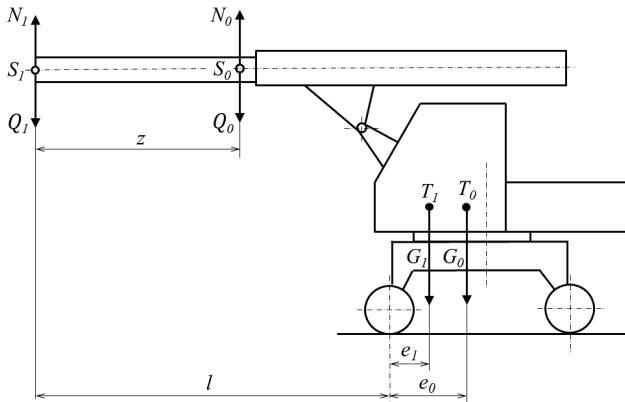

Figure 1 Solution of moment balance on the telescopic jib

1. Fully extended internal arm (point S_1)

$$Q_1 \cdot l = G_1 \cdot e_1 \tag{1}$$

2. Fully inserted internal arm (point S_0)

$$Q_0 \cdot (l - z) = G_1 \cdot e_0 \tag{2}$$

The intensity of external loading force Q_1 at fully extended jib or Q_0 in fully inserted jib in case of the balance of stabilizing moments is then:

$$Q_1 = \frac{e_1}{l} \cdot G_1 \tag{3}$$

or

$$Q_0 = \frac{e_0}{(l - z)} \cdot G_1 \tag{4}$$

In the horizontal plane, the telescopic jib is loaded by the components of forces generated during inserting the internal telescopic jib arm or by eccentric forces applied to the working tool at the end of the internal arm.

For dimensioning and the analysis of the state of stress concerning the internal arm, it is necessary to observe the whole operational capacity of the internal arm which is given by length of its extending from the zero position up to the position of maximum extension. For the complete range of extension we have to find out the intensities of reaction in the front and back jockey wheels and the level of bending moment. From the viewpoint of stressing the internal arm, an unfavourable position appears to be the maximally extended internal arm in the horizontal position loaded by external force Q (event. force N). Even more unfavourable stressing occurs when vertical force acts eccentrically when load of torsion moment joins bending stressing.

Optimization can be defined as a process of achieving such a construction design which is the best of all possible designs with respect to the prescribed aim and the given

set of geometric limits to behaviour (state) of the system. [12] From the viewpoint of the problem specification in case of the telescopic jib, it is suitable to set the internal (extensible) arm of the telescopic jib as an object of the optimization analysis. The change of some of its strength parameters (except height and width of bearing cross-section) has the least response to interlinked constructional parts of the equipment in the system: *internal arm* → *external arm* → *equipment frame* → *all the equipment*. As the external dimensions of the arm have to be retained, the only possibility to optimize the bearing cross-section is only to modify the thickness of bearing plates. It is also due to the fact that the construction, in principle, does not enable the use of additional cross bracing. Actually, inside the arm there is a linear hydraulics for arm extension and hydraulic distribution of control of the working equipment.

2 Method

An example of such optimization process is optimization of the internal telescopic jib arm (Fig. 3) of the universal working equipment UPS-112 (Fig. 2) developed by the WUSAM a.s. Zvolen and prepared for the production in the CSM Tisovec a.s.



Figure 2 UPS-112

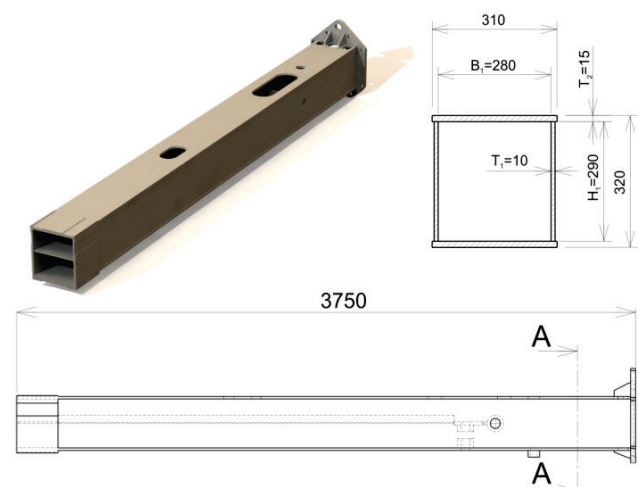

Figure 3 Design and basic dimensions of the telescopic jib

Optimization calculations have been carried out by the method of finite elements by means of the ANSYS software which is owned by the Department of Mechanics and Mechanical Engineering, the Technical University in

Zvolen. The theoretical and practical bases for carrying out these calculations were the results of experimental tests done on the prototype of the UPS-112 equipment. During the test was measured the tilt load of the equipment according to the previous considerations of the main load force. The tilt load has been measured by means of the tensometric dynamometer and the measuring probe of 200 kN.

Moreover, the tensometric measurements have been carried out on predetermined parts of the telescopic jib. For this purpose, the equipment for data collection and processing, model DAQ-664 (Fig. 4), produced by Kraus Messtechnik GmbH) and the tensometers models 3/120LY111 and 6/120RY11 (produced by HB Messtechnik, Germany) have been used.



Figure 4 Data logging and processing equipment

The obtained measured values of tilt load have been the input parameters for the analysis of the state of stresses and strains and also for optimization by means of the FEM. The data obtained by tensometric measuring served to verify correctness of the calculation model, when achieved measured values of stresses and proportional deformations on the prototype were compared to calculated values. The comparison of calculated data and results of tests has been carried out in two ways. The former one was to find out stresses and deformations on trajectories which were passing through the places of measurement by the application of the command *Path Operation* in the *General Postprocessor* menu.

The latter one was to find out values directly in the particular nodes in hypothetical places of mounted tensometers using the command *Query Results* → *Subgrid Solution*. Comparing the calculated values and measured values, we have found out that the data are similar and so the closer calculation model is correct.

The basis for creating the calculation model for ANSYS was the 3D model designed in the Creo Parametric software. The transfer of 3D geometry of the model into the ANSYS environment was carried out by the application of the *Import* command which enables a direct download of its geometry in the form of volumes, areas and key-points. Two calculation models have been created. One was created by means of the type element SOLID95, the other one by means of the type element SHELL63.

SOLID95 is a higher version of the 3D 8-node solid element (SOLID45). It can tolerate irregular shapes without as much loss of accuracy. SOLID95 elements have compatible displacement shapes and are well suited to model curved boundaries. The element is defined by 20 nodes having three degrees of freedom per node: translations in the nodal x , y , and z directions. The element may have any spatial orientation. The element has plasticity, creep, stress stiffening, large deflection, and large strain capabilities [6].

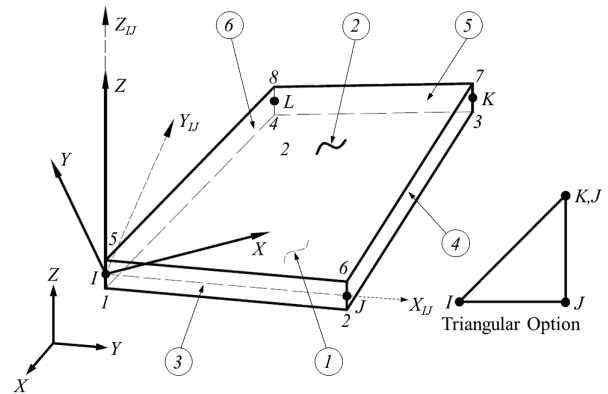

Figure 5 Planar element SHELL63

Planar element SHELL63 (Fig. 5), has both bending and membrane capabilities. Both in-plane and normal loads are permitted. The element has six degrees of freedom at each node: translations in the nodal x , y , and z directions and rotations about the nodal x , y , and z axes. Stress stiffening and large deflection capabilities are included. A consistent tangent stiffness matrix option is available for use in large deflection (finite rotation) analyses [12]. Parameters of both meshed calculating models are given in Tab. 1.

Table 1 Parameters of meshed models

	ELEMENTS	NODES	AREAS	LINES
SOLID95	39 197	77 178	424	882
SHELL63	13 110	13 301	239	600

Optimizing calculations have been made on the calculating model created by means of the planar element type SHELL63 (Fig. 6).

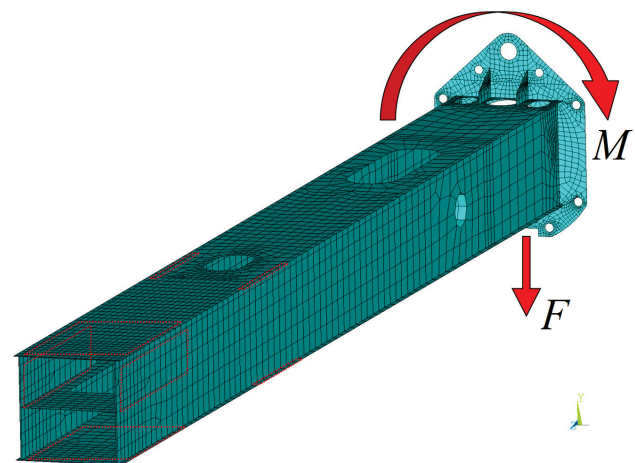

Figure 6 FEM model created from SHELL63 elements

It was mainly for the reason that calculating model created from the elements of SHELL63 type was less time-consuming in the applied hardware. The decision to use the specific element type was made also because the analysis of the state of stresses and deformations, which had been carried out before optimizing calculations on both model types, showed almost no differences in the results.

The calculations have been carried out in 11 different load states of external load. The main task of calculations was to optimize bearing panel thickness of the internal arm.

The first optimizing calculation was carried out for the load acting in the axis of symmetry of the arm. Next ten calculations differed from this alternative by the fact that external load force in particular cases gradually worked outside the mentioned axis of symmetry, i.e. it affected the particular arm.

As a final consequence, it caused that, in addition to bending moment, the jib arm is loaded also by torsion moment. The intensity of the moment was being increased, so that the arm of torsion moment has gradually increased from the zero position up to 1 m. The increase of the arm for particular calculation positions was determined as 0,1 m. In all cases the external load force equalling tilt force (28,2 kN) was considered.

3 Results

The result of optimizing calculations has been the finding out alternatives of bearing plates thickness. The alternative values are presented in Fig. 7 and Tab. 2.

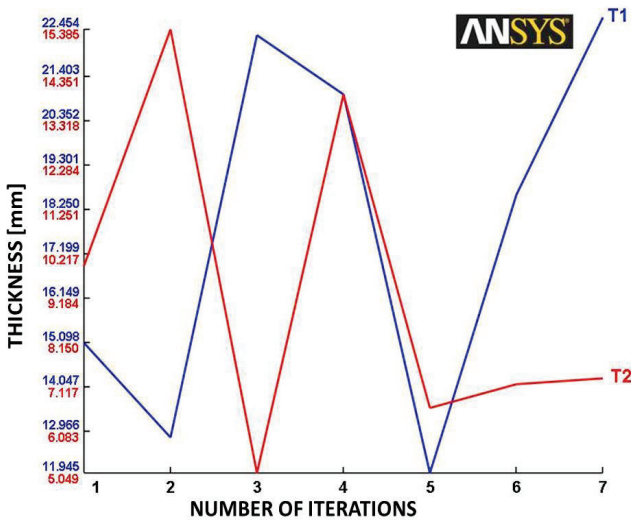

Figure 7 Alternative thicknesses of plates

ANSYS needs to know which variables are critical to the optimization. To define variables, we need to know which variables have an effect on the variable to be minimized. In this example our objective is to minimize the volume of an internal telescopic jib arm which is directly related to its weight.

ANSYS categorizes three types of variables for design optimization:

Design Variables (DV) - Independent variables that directly affect the design objective. In this example, the thickness of plates (T1, T2) and basic internal dimensions (B1, H1) of the telescopic jib arm are the DVs. Changing these variables has a direct effect on the solution of the problem.

State Variables (SV) - Dependent variables that change as a result of changing the DVs. These variables are necessary to constrain the design. In this example, the SV is the maximum equivalent von Mises stress in the telescopic jib arm with upper limit of 275 MPa.

Objective Variable (OBJ) - The objective variable is the one variable in the optimization that needs to be minimized. In our problem it was the volume of the internal telescopic jib arm.

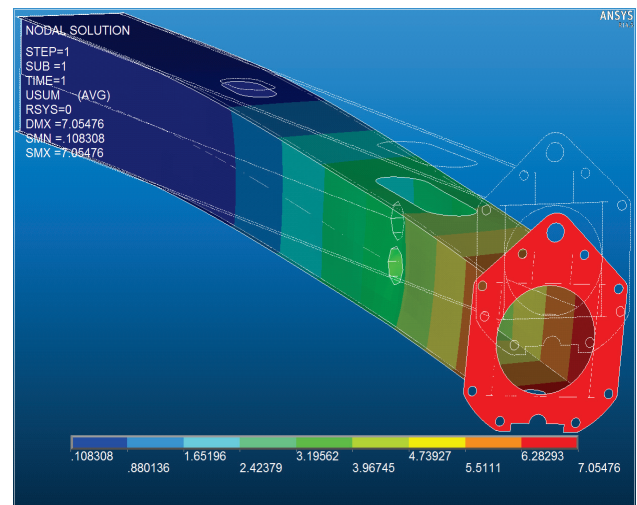

Figure 8 Displacement summary - enlarged scale

Due to the extent of the article, there are given only optimization parameters of load force affecting the considered maximum arm of load force. Displacement summary in case of the maximum external load force and maximal torsion moment is presented in Fig. 8.

In addition to stated thickness of plates (T1 and T2), other input optimization parameters (Tab. 2, B1 and H1) are also included in the graph, which have not been considered and evaluated because of the extension of the work.

The basic dimensions and parameters of the objective arm are stated in Fig. 2. The design of steel constructions within the present complexity of machinery cannot be only a matter of designer's sense and intuition. The application of such unprofessional processes often leads to degradation of the initial intention of the technical solution. Eventually, this implies the two extremes – the construction is either overextended or under extended [1].

The first case means an unreasonable and excessive increase of weight, which is not so disastrous from the viewpoint of overall functionality of the given construction [8].

The under sizing may bring more after-effects. In this case, such stresses and deformations can cause destruction of some part or several parts of the construction. Thus, the construction cannot meet functions which it was initially designed for [3].

Table 2 List of optimization sets - Output from the ANSYS (SET 1 - basic design)

LIST OPTIMIZATION SETS FROM SET 1 TO SET 7 AND SHOW ONLY OPTIMIZATION PARAMETERS (A "*" SYMBOL IS USED TO INDICATE THE BEST LISTED SET)				
	SET 1 (FEASIBLE)	SET 2 (FEASIBLE)	SET 3 (INFEASIBLE)	SET 4 (FEASIBLE)
SMAX (SV)	273,424	269,293	277,128	267,397
H1(DV)	290,00	296,18	288,44	286,73
B1(DV)	280,00	279,14	282,36	276,41
T1(DV)	10,000	12,760	21,957	20,855
T2(DV)	15,000	15,386	5,0499	13,732
VOLUME (OBJ)	6,6687630E+07	6,6687531E+07	6,6687427E+07	6,6687497E+07
	SET 5 (FEASIBLE)	SET 6 (INFEASIBLE)	SET 7 (FEASIBLE)	
SMAX(SV)	270,324	278,284	268,953	
H1(DV)	292,38	288,24	297,17	
B1(DV)	271,40	289,79	287,37	
T1(DV)	11,946	17,633	22,454	
T2(DV)	6,6867	7,2634	7,2354	
VOLUME (OBJ)	6,6687413E+07	6,6687615E+07	6,6687623E+07	

4 Conclusion

The telescopic jib represents a relatively complex bearing steel construction. Although particular construction designs are quite different, their calculation scheme is essentially identical. As it has been already mentioned in the previous chapters, from the viewpoint of calculation it is important to take into consideration more calculation positions of specific jib arms.

Within the positions, it is necessary to analyse specific elements of external load and to find the most unfavourable combination of the arm positions and external load. Such a combination seems to be maximally extended jib at eccentrically acting external load force. With regard to the above mentioned facts we can carry out the analysis of stresses and deformations. However, we do not consider only this specific situation, but each situation where extreme values of stresses and deformations can be assumed.

By application of the FEM in connection with the computer equipment, it is possible to cope fully with the problem of optimization of any steel construction including the telescopic jib [11]. The obtained results can form a general theoretical background for designing the specific types of telescopes because such a publication of the know-how has not been available up to now.

5 References

- [1] Dekýš, V.; Sága, M.; Žmindák, M. Some Aspects of Structural Optimization by Finite Element Method. // Innovation and Utilization in the Visegrad fours. Hungary, 2005. ISBN 96386918 24.
- [2] Dekýš, V.; Sága, M.; Žmindák, M.; Hřečková, A. Structural Optimization by Finite Element Method. // Acta Mechanica Slovaca, 2005. ISSN 1335-2393.
- [3] Sága, M.; Kocúr, R.; Dekýš, V.; Žmindák, M. Contribution to discrete structural optimization. // Scientific Bulletin, Volume XIX, Serie C, North university Baia Mara, 2004, ISSN 1224-3264.
- [4] Žmindák, M.; Sága, M.; Tvaružek, J.; Husár, Š. Optimalizácia mechanických sústav. Vydavateľstvo EDIS. Žilina, 2000.
- [5] Kolář, V.; Němec, I.; Kanický, V. FEM – Principy a praxe metody konečných prvků. Praha, 1997.

- [6] Hong-Seok, P.; Xuan-Phuong, D. Structural optimization based on CAD-CAE integration and metamodeling techniques. // Computer-Aided Design. 42, 10(2010), pp. 889-902, ISSN: 0010-4485.
- [7] Xianghua, X.; Peng, W.; Michael, Y. W. Structural optimization based on CAD-CAE integration and metamodeling techniques. // International Journal for Numerical Methods in Engineering. 82, 7(2010), pp. 805-842, ISSN: 1097-0207.
- [8] Dijk, N. P.; Maute, K.; Langelaar, M.; Keulen, F. Level-set methods for structural topology optimization: a review. // J. Structural and Multidisciplinary Optimization. 48, 3(2013), pp. 437-472, ISSN: 1615-147X,
- [9] Krishnan, S.; Meisam, T. Stress-constrained topology optimization: a topological level-set approach. // J. Structural and Multidisciplinary Optimization. 48, 2(2013), pp. 295-309, ISSN: 1615-147X, doi: 10.1007/s00158-012-0807-3.
- [10] Holmberg, E.; Torstenfelt, B.; Klarbring, A. Stress constrained topology optimization. // J. Structural and Multidisciplinary Optimization. 48, 1(2013), pp. 33-47, ISSN: 1615-147X, doi: 10.1007/s00158-012-0880-7.
- [11] Belegundu, A. D.; Tirupathi, R. Ch. Optimization Concepts and Applications in Engineering. 2nd Edition, May 2014, Pages 480, ISBN: 9781107674172
- [12] ANSYS Structural Release 14.5: Help Topics
- [13] ANSYS Workbench Tutorial Release 14
- [14] Creo Parametric Release 2.0: Help Topics

Authors' addresses

Pavel Beňo, Doc. Ing. PhD.

Technická univerzita vo Zvolene
Fakulta environmentálnej a výrobnjej techniky
Študentská ulica 26, 960 53 Zvolen, Slovakia
Tel +421 045 5206 871, E-mail: pavel.beno@tuzvo.sk

Dražan Kozak, Prof. dr. sc.

J. J. Strossmayer University of Osijek
Mechanical Engineering Faculty in Slavonski Brod
Trg Ivane Brlic Mazuranic 2, 35000 Slavonski Brod, Croatia
Tel. +385 35 493 452, E-mail: dkozak@sfsb.hr

Pejo Konjatić, Doc. dr. sc.

J. J. Strossmayer University of Osijek
Mechanical Engineering Faculty in Slavonski Brod
Trg Ivane Brlic Mazuranic 2, 35000 Slavonski Brod, Croatia
Tel. +385 35 493 424, E-mail: pekon@sfsb.hr



Location

Situated on the eastern coast of Spain, València was founded in 138BC as a Roman colony. The city, which is the third largest in Spain, has the biggest port on the Mediterranean Sea. A large historic city centre makes València a popular tourist destination with many ancient monuments, museums and sights of interest. València is famous for "Les

Falles" – four days and nights of city wide celebrations held each year during March in commemoration of Saint Joseph. Visitors are also drawn to the region for its food with Paella having originated from the city.

Conference Venue

The TRYP València Oceanic Hotel is situated near the centre of València. Only a short distance from the City of Arts and Sciences, the harbour and downtown, the hotel is close to all that the city has to offer. With 200 rooms all with high speed internet access, a 24 hour fitness centre, pool, sauna, bar and restaurant, the hotel has all the amenities guests may require.

Submission Information

Papers are invited on the topics outlined and others falling within the scope of the meeting. Abstracts of no more than 300 words should be submitted as soon as possible.

Abstracts should clearly state the purpose, results and conclusions of the work to be described in the final paper. Final acceptance will be based on the full-length paper, which if accepted for publication must be presented at the conference.

The language of the conference will be English.

Online submission:

wessex.ac.uk/materials2015

Email submission

imoreno@wessex.ac.uk

Submit your abstract with 'Materials Characterisation 2015' in the subject line.

Please include your name, full address and conference topic.

Conference Secretariat

Irene Moreno Millan

imoreno@wessex.ac.uk

Wessex Institute
Ashurst Lodge, Ashurst
Southampton, SO40 7AA, UK

Tel: +44 (0) 238 029 3223

Fax: +44 (0) 238 029 2853

For more information visit:
wessex.ac.uk/materials2015



CALL FOR PAPERS

MATERIALS CHARACTERISATION 2015

7th International Conference on Computational Methods and Experiments in Materials Characterisation

22 – 24 April 2015
València, Spain

Organised by

Wessex Institute, UK

Sponsored by

WIT Transactions on Engineering Sciences
International Journal of Computational
Methods and Experimental Measurements



WESSEX INSTITUTE
ADVANCING INTERNATIONAL
KNOWLEDGE TRANSFER

wessex.ac.uk/materials2015



Following the success of the six previous meetings in this series (Santa Fe, New Mexico, in 2003; Portland, Maine, in 2005; Bologna, Italy, in 2007; New Forest Campus of the Wessex Institute in 2009; Kos, Greece, in 2011 and Siena, Italy, in 2013), it has been decided to reconvene the International Conference of Computational Methods and Experiments in Materials Characterisation.

The aim of the conference is to facilitate interactions within the research community and discuss the latest developments in this rapidly advancing field. The meeting responds to the demand for high quality products for both industry and consumers, which has led to rapid developments in materials science and engineering. This requires the characterisation of the physical and chemical properties of the materials. Consideration of different experimental techniques as well as computer simulation methods is essential to achieve a proper analysis. A very wide range of materials,

starting with metals through polymers and semiconductors to composites, necessitates a whole spectrum of material characterisation experimental techniques and numerical methods.

All papers to be published in the conference volume as well as those from previous meetings are permanently archived in the Wessex Institute eLibrary (<http://library.witpress.com>) where they are available to the international community.

Benefits of Attending

Conference Proceedings Papers presented at Materials Characterisation 2015 will be published by WIT Press in Volume 90 of WIT Transactions on Engineering Sciences (ISSN: 1746-4471 Digital ISSN: 1743-3533). WIT Press ensures maximum worldwide dissemination of your research through its own offices in Europe and the USA, and via its extensive international distribution network.

Delegates will have the choice of receiving the conference book as either hard cover or digital format on a USB flash drive. The USB flash drive will, in addition, contain papers from previous conferences in this series.

Indexing and Archiving Papers presented at Wessex Institute conferences are referenced by CrossRef and regularly appear in notable reviews, publications and databases, including referencing and abstracting services such as SCOPUS, Compendex, Thomson Reuters Web of Knowledge and ProQuest. All conference books are archived in the British Library and American Library of Congress.

Digital Archive All conference papers are archived online in the WIT eLibrary (<http://library.witpress.com>) where they are easily and permanently available to the international scientific community.

Journal Papers After the conference, presenters at Materials Characterisation 2015 will be invited to submit an enhanced version of their research for possible publication in the International Journal of Computational Methods and Experimental Measurements published by the Wessex Institute.

Reviews Abstracts and papers are reviewed by members of the International Scientific Advisory Committee and other experts.

Open Access Open Access allows for the full paper to be downloaded from the WIT eLibrary archives, offering maximum dissemination. Authors who choose this option will also receive complimentary access for one year to the entire WIT eLibrary.

Networking Participants can present their research and interact with experts from around the world, becoming part of a unique community.

Reduced Fee for PhD Students The Wessex Institute believes in the importance of encouraging PhD students to present and publish innovative research at their conferences. As a result, the Institute offers PhD students a much reduced conference fee.

Conference Topics

Cementitious materials

Computational models and experiments

Corrosion problems

Advances in composites

Micro and macro materials characterisation

Fracture and fatigue problems

Mechanical characterisation and testing

Recycled materials

Structural health monitoring

Energy materials

Citations When referencing papers presented at this conference please ensure that your citations refer to **Volume 90 of WIT Transactions on Engineering Sciences** as this is the title under which papers appear in the indexing services.

