

# SIMULATION AND APPLICATION OF LOOSE TOOLING FORGING FOR HEAVY GRINDING ROLLER SHAFT FORGINGS

J. Su\* – F. Ren –S. Jia –S. Wei

School of Material Science Engineering, Henan University of Science and Technology, Luoyang 471003, China

## ARTICLE INFO

### Article history:

Received: 08.11.2013.

Received in revised form: 12.01.2013.

Accepted: 14.01.2014.

### Keywords:

Grinding roller shaft

Loose tooling forging

Numerical simulation

Rectangular cross-section

Heavy forgings

## Abstract:

*The grinding roller shaft is a key part of the grinding roller. It has a step-shaped shaft with different round cross-sections and 1850 mm × 1110 mm rectangular cross-section. If the general method of free forging is used, the upsetting diameter of ingot will reach 2900 mm, and 8400 t hydraulic press current will not be produced so that the loose tooling forging process is to be used. The loose tooling forging process of rectangular flange has been researched by using DEFORM-3D simulation software and establishing a reasonable forging process. The production results reveal that the heavy forgings used as grinding roller shafts can be successfully produced with the present 8400 t capacity hydraulic presses. The eligible forgings have proved the rationality of the technical process.*

## 1 Introduction

As a vertical mill has advantages of high efficiency, low power consumption, strong drying capacity and an easy operation, it is used widely in domestic cement industry. The ATOX grinding roller represents a vertical mill. The grinding roller shaft is a key part of the ATOX grinding roller and belongs to heavy forgings. The size of the grinding roller shaft increases with the development of the large-scale equipment. It has a step-shaped shaft with different round cross-sections and 1850 mm × 1110 mm rectangular cross-section as shown in Fig.1. When free forging method is used the upsetting diameter of ingot should reach 2900 mm so as to ensure the effective permeability. The hydraulic press optimized for the capacity of 8400 t cannot be produced. So, the loose tooling forging process is used according to the shape and characteristics of the grinding roller shaft.

In general industrial forging, the size and weight of forgings machined by loose tooling forging are small [1-5]. Reference [6] reveals that the dimension of the flange is  $\phi$  530 mm × 135 mm, and Reference [7] shows that the dimension of the flange is  $\phi$  388 × 125 mm. It is difficult to control the loose tooling forging process of the heavy forgings with complex shape of the four angles as shown in Fig. 1. Actually, there have been no reports on it so far. Reference [8] analyzed a three-dimensional rigid-plastic finite element method for optimizing an open die forging process in the production of circular shapes. In this paper the loose tooling forging process for grinding the roller shaft is studied by using software Deform-3D to simulate the loose tooling forging process of the rectangular part.

The reasonable forging process is available by the simulation results and is applied to production practices. The eligible forgings are produced.

\* Corresponding author. Tel.: +86 37965627751 ; fax: +86 37965627751  
E-mail address: sujh@haust.edu.cn

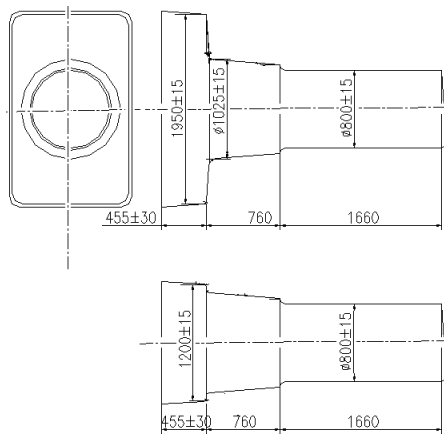

Figure 1. Forging drawing of grinding roller shaft.

## 2 Simulation model

The forging model is established according to the shape and volume of forging drawing of grinding roller shaft. The forging model of the rectangular flange is 1050 mm × 1750 mm × 750 mm. The size of the neck area is  $\phi$  1000 mm × 680 mm. The size of the die coincides with forgings as shown in Fig. 2. The forging material is 42CrMo4.

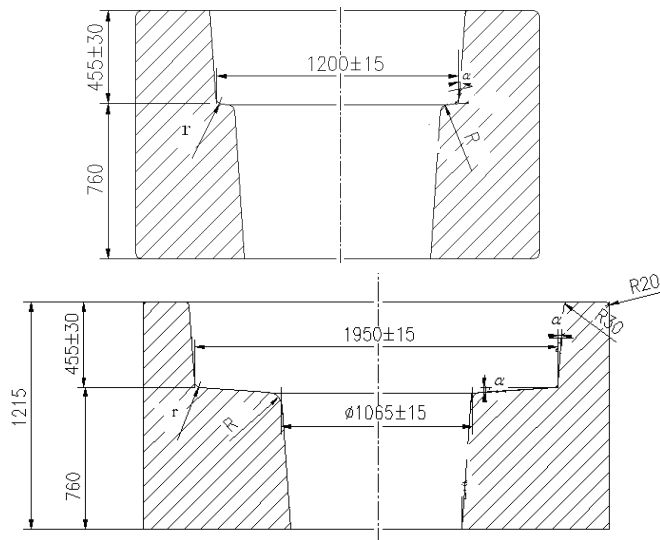

Figure 2. Die structure.

There are many influence factors in hot forging, such as stress, strain rate and deformation temperature. The constitutive equation of 42CrMo4 is:

$$\bar{\sigma} = \bar{\sigma}(\bar{\varepsilon}, \dot{\bar{\varepsilon}}, T) \quad (1)$$

where  $\dot{\bar{\varepsilon}}$  - equivalent strain rate,  $\bar{\varepsilon}$  - equivalent strain,  $T$  - deformation temperature.

The temperature of the forging material is 1200 °C. The temperature of the die and anvil is set at 500 °C. The coefficient of thermal mechanical coupling is 5. The friction coefficient between the material 42CrMo4 and dies is 0.3. The meshed plastic model is shown in Fig. 3. Software Deform-3D and a three-dimensional rigid-plastic finite element method are used.

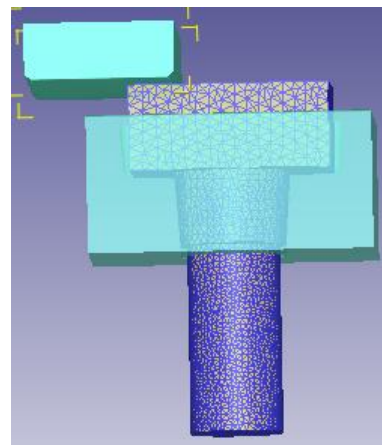

Figure 3. Finite element model.

## 3 Simulation results

Table 1 shows the numerical simulation schemes of loose tooling forging. There are five schemes. Schemes 1, 2 and 3 are single-pass feeds of an anvil. Schemes 4 and 5 are double-pass feeds of an anvil.

Fig. 4 shows the simulation results of loose tooling forging. From the results of the first scheme simulation as shown in Fig. 4 a), we can see that forgings surface quality was poor. Not only was the metal flow at both ends very uneven, but also forming defects were still evident in the middle of the slug. It can be explained that the heated metal flows from one side to the other side, and more metal accumulates at the other side of the die. Fig. 4 b) showed that the distribution of metal flow was better than that of the first scheme. But the slug was not completely filling the die and did not meet the requirements of forging shape. The metal flow was not very uniform.

Table 1. Simulation schemes of the loose tooling forging

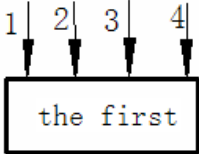
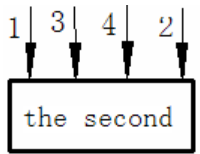
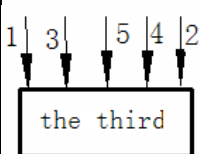
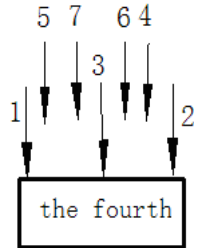
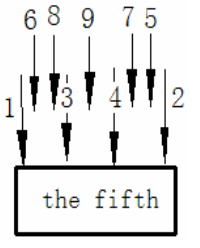
1	2	3	4	5
 <p>the first</p>	 <p>the second</p>	 <p>the third</p>	 <p>the fourth</p>	 <p>the fifth</p>
<p>The forging process single-pass, four feeds of anvils from one side to the other side of the blank.</p>	<p>The forging process single-pass, four feeds of anvils from two sides to the middle of the blank.</p>	<p>The forging process single-pass, five feeds of anvils from two sides to the middle of the blank.</p>	<p>Double-pass, seven feeds of anvils, both from two sides to the middle of the blank.</p>	<p>Double-pass, nine feeds of anvils, both from two sides to the middle of the blank.</p>

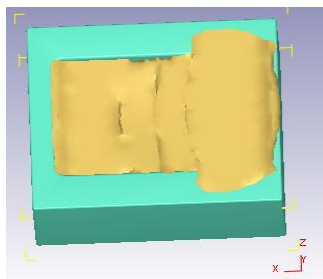

a) the first scheme

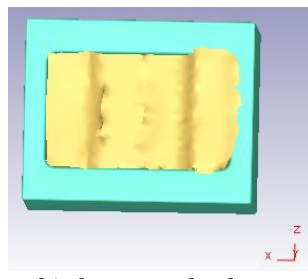

b) the second scheme

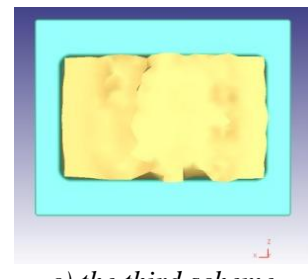

c) the third scheme

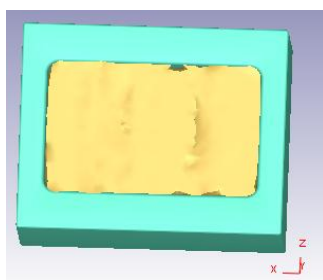

d) the fourth scheme

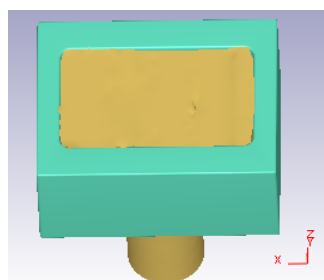

e) the fifth scheme

Figure 4. Simulation results of loose tooling forging.

Since the small feed of the anvil is beneficial to the metal flow, the third scheme simulation has five feeds of the anvil. Fig. 4 c) reveals that the results are still not ideal. Not only are the corners of the die partially filled with metal, but also there exist pairs of drum-type defects at the sides of the forgings.

The fourth scheme simulation presented in Fig. 4 d) shows that the simulation effect has been greatly improved. There are no defects in the middle of the slug. The surface of the forgings has only some minor folding defects. Apparently, two rows feed of anvil have improved the forming quality to a certain extent. The results are satisfactory in the width

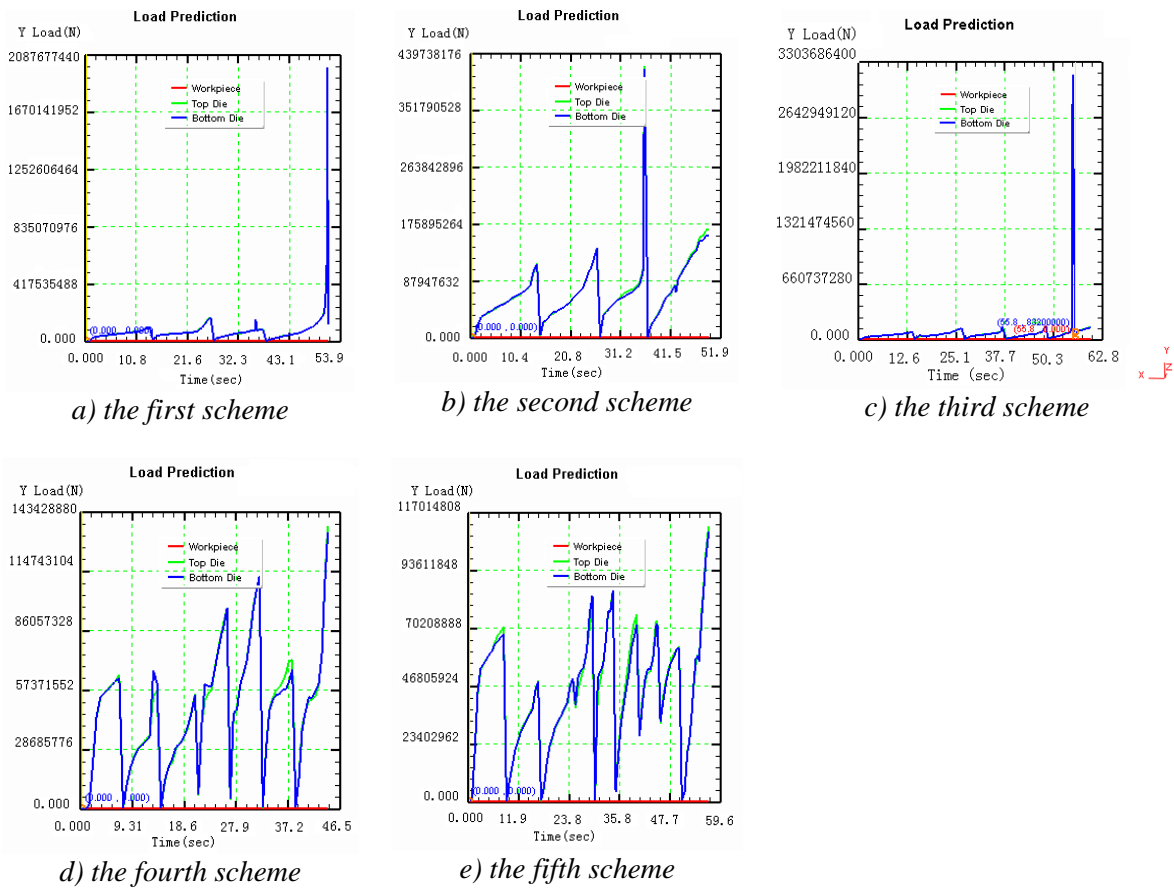

Figure 5. Force curves.

direction, but the die is not filled with the metal in the length direction.

The fifth scheme simulation has two more feeds of anvil than the fourth scheme. The forging quality has been improved significantly and the die is well filled with the metal both in the width direction and in the length direction. Also, the four corners of the die are well filled with the metal as shown in Fig. 4 e).

Fig. 5 shows the five kinds of force curves during the simulation of the loose tooling forging. Figure 5 reveals that the forces in the first, second, third and fourth scheme simulations are large and beyond the capacity of 8400 t of the hydrostatic press which is used in practical production. The forming force has been well improved by using double-pass feed. The force of the anvil in the fifth scheme simulation is not beyond the capacity of the present 8400 t hydrostatic press.

From above analysis, simulation of the fifth forging scheme is more reasonable. Not only is the quality of the rectangular flange forming satisfactory, but

also the forming forces are more reasonable. They are not beyond the capacity of 8400 t hydrostatic press.

#### 4 Practice production

Based on the simulation results, practice production makes use of the fifth simulation forging forming process for grinding roller shaft. The ideal forging products are available as shown in Fig.6.



Figure 6. Practice product.

## 5 Conclusion

- 1) In order to prevent non-uniform metal flow and the severe metal remainder at one side of the die in loose tooling forging, the forging method from one side to the other side should not be used.
- 2) The method of using two rows small feed of anvil is conducive to the uniform flow of metal and the forging force meets the requirement of equipment.
- 3) The fifth forming simulation is suitable for the heavy forgings through comparison of the simulation results. The result of simulation provides theory guide for good manufacturing practice production of grinding roller shafts.

## Acknowledgements

This work is funded by Program for Changjiang Scholars and Innovative Research Team in University (IRT1234), and by the Science and Technology Research Project of Henan Province 102102210174.

## References

- [1] Chen, K., Yang, Y.T., Shao, J., Liu, K.: *Strain function analysis method for void closure in the forging process of the large-sized steel ingot*, Computational Materials Science, 51 (2012), 72-76.
- [2] Banaszek, G., Szota, P.: *A comprehensive numerical analysis of the effect of relative feed during the operation of stretch forging of large ingots in profiled anvils*, Journal of Materials Processing Technology, 169 (2005), 437-441.
- [3] Makino, T.: *The effect of inclusion geometry according to forging ratio and metal flow direction on very high-cycle fatigue properties of steel bars*, International Journal of Fatigue, 30 (2008), 8, 1409-1415.
- [4] Han, B.D., Xu, Z.: *Microstructural evolution of Fe-32%Ni alloy during large strain multi-axial forging*, Materials Science and Engineering A, 447 (2007), 1-2, 119-123.
- [5] Bruschi, S., Ghiotti, A.: *Distortions induced in turbine blades by hot forging and cooling*, International Journal of Machine Tools & Manufacture, 48 (2008), 7-8, 761-766.
- [6] Wen, T. J.: *A Study of the Technology for the Opened-die Forging of Centre Pipe* [J]. Heavy Machinery, 6, (2000), 19-22, 48. (in Chinese)
- [7] Gao, B. G.: *Die Forging Technology For Heavy Piston* [J]. Metal Forming Machinery, 2001, 36(1):11-13. (in Chinese)
- [8] Choi, S. K., Chun, M. S., Van Tyne, C. J., Moon, Y. H.: *Optimization of open die forging of round shapes using FEM analysis*, Journal of Materials Processing Technology, 172 (2006), 1, 88-93.