

Galectins: A New Family of Lectins

Gordan Lauc and Mirna Flögel

Department of Biochemistry and Molecular Biology, Faculty of Pharmacy and Biochemistry, University of Zagreb, Domagojeva 2, 10000 Zagreb, Croatia

Received February 3, 1995; revised May 16, 1995; accepted July 26, 1995

Lectins are defined as carbohydrate binding proteins other than enzymes and antibodies. Until recently, lectins were considered to be exclusively plant proteins and as such drew only limited attention of biochemists. As soon as they were detected in animal cells and after their involvement in vital processes such as development, differentiation and neoplastic growth was recognized, widespread studies have focused on their specificity, structure, localization and specific biological functions.

Very recently, several β -galactose specific lectins were organized into a new lectin family – *galectins*. Members of this family are present in nearly all animals, from lower invertebrates such as sponges and nematodes to mammals, including humans. Though not completely understood, the awareness of their physiological importance is increasing as their properties are unraveled, and the interest in them is ascending as multiple implications of their presence are emerging.

The term *lectin* (derived from the Latin word *legere*, to pick out, choose or select) was introduced by Boyd and Schapleigh¹ to describe a class of plant proteins which agglutinate cells and exhibit sugar binding specificity. Since then, several attempts have been made to reach a more specific, yet common definition of lectins. In a *Letter to Nature*, Goldstein *et al.*² suggested a definition of lectins as »sugar-binding proteins or glycoproteins of nonimmune origin which can agglutinate cells and/or precipitate glycoconjugates«. To include the monovalent carbohydrate binding proteins into lectins, Kocurek and Horejsi³ proposed a modified definition which stated that »lectins have at least one binding site«. Barondes⁴ then suggested a simpler definition: »Lectins are carbohydrate-binding proteins other than enzymes or antibodies«. However, in the light of the present knowledge of lectins, even this broad definition seems to be inadequate.

Although known for more than a century,⁵ it was only during the late 1960s that lectins started to attract wider attention.⁶ This was prompted mainly by the studies which demonstrated lectins as useful reagents for the detection and isolation of glycoproteins and for following changes in cell-surface sugars in processes like development, differentiation and neoplastic transformation.

The first crucial step in the research of physiological functions of lectins was a discovery made by Peter C. Nowell at the University of Pennsylvania, Philadelphia, who found that lectin of the red kidney bean (*Phaseolus vulgaris*), known as phytohemagglutinin or PHA, is mitogenic, *i.e.* it possesses the ability to stimulate lymphocytes to undergo mitosis.⁷ Within a short time, several other lectins were also found to be mitogenic. Of special importance was the finding that Concanavalin A (from *Canavalia ensiformis*) acts as a mitogen since, in contrast to PHA, its activity could be inhibited by low concentrations of monosaccharides, *e.g.* D-mannose or D-glucose. This was one of the first demonstrations of the biological role of cell surface glycoconjugates.⁸

In the 1970s, it became well established that almost all cells carry carbohydrates on their surface in the form of glycoproteins, glycolipids, and polysaccharides.⁸ It was concurrently realized that carbohydrates have an enormous potential to encode information.^{9,10} In peptides and oligonucleotides, the information content is based only on the number of monomeric units and their sequence, whereas in carbohydrates, information is also encoded in the position and anomeric configuration (α or β) of the glycosidic unit, and in the occurrence of branching points.¹¹ The number of theoretically possible forms that can be produced from two or three of the same sugars is enormous (Table I). Some of these configurations are probably prohibited by stereochemical limitations, but the number of the remaining allowed structures is still very high.

Further structural diversification of glycoconjugates may occur by covalent attachment of sulfate, phosphate, and acetyl groups to sugars. Such a high number of different structures that can be created from a limited number of monosaccharides led Sharon, as early as in 1975, to hypothesize that »the specificity of many natural polymers is written in terms of sugar residues and not of amino acids or nucleotides«. ¹³ The current knowledge of the biosynthetic machinery which generates the carbohydrate structures suggests that glycosyltransferases responsible for the assembly process have highly specific substrate requirements and that each enzyme generates only a very limited number of bonds. Thus, the diversity existing in carbohydrate structures presumably arises from a multiplicity of synthetic enzymes, suggesting that information can be, and probably is encoded in carbohydrates.^{14,15}

Despite more than a century long investigation of lectins, the idea that lectins may act as cell recognition molecules is less than two decades old. In 1980, Harrison and Chesterton¹⁶ proposed that a group of low M_r β -galactoside-specific animal lectins, which they called galaptins, might mediate adhesion *via* a cell-cell bridging mechanism. The background for this hypothesis was the realization that surface carbohydrates may function in cell

TABLE I

*Diversity of dimeric and trimeric forms of saccharides and peptides.*¹² Theoretical number of different structures which could be formed from dimeric and trimeric monosaccharides and amino-acids.

Composition	Number of isomers	
	Saccharides	Peptides
a-a (dimer)	11	1
a-a-a (trimer)	176	1
a-b-c (trimer)	1056	6

recognition^{17,18} and the demonstration that lectins are not confined to plants, as originally believed, but are ubiquitous in nature.^{19,20}

Hundreds of lectins are now well characterized and the number is still growing fast. They have been isolated from microorganisms, plants and animals. Despite their high structural diversity, it is possible to group most lectins into several families of homologous proteins that share common structural properties (Table II).

As recently as 1986, a review on lectins devoted only a single page to animal lectins.²⁰ In the meantime, a large number of lectins have been isolated from different animal species, and the field is expanding rapidly. Approximately one hundred animal lectins have been characterized at the primary structure level. The list of lectin-mediated processes already includes diverse biological phenomena, from intracellular routing of glycoproteins to regulation of cell-cell adhesion and phagocytosis. Lectin domains have been recently discovered in several previously well characterized proteins like the tumor necrosis factor, and distinct and significant functions have been attributed to these domains.²¹ Some lectins even seem to participate in the stress response²² and in the lesion-induced regeneration and neosynaphthogenesis in the brain.²³

According to the structure of the carbohydrate recognition site (carbohydrate recognition domain – CRD), lectins in the animal kingdom can be divided into two families: (i) the family of calcium-dependent lectins (C-type), and (ii) the family of metal-independent β -galactoside-binding lectins (S-type).¹⁴ Very recently, a novel name galectins has been proposed for the S-type lectins.²⁴

Galectins (S-type lectins)

Galectins are a relatively small family. At the moment, it comprises only three groups of lectins (Figure 1): (i) several 13–16 kDa lectins called galectin-1, galectin-2, galectin-5 and galectin-7 (previously known as L-14, or proto-type lectins); (ii) 29–35 kDa lectin called galectin-3 (previously known as L-30, or chimera type lectin), and (iii) 36 kDa lectin called galectin-4 (previously known as L-36, or tandem-repeat type lectin).

TABLE II

Lectin families. Lectins in plants are divided into families that correspond to the species from which they have been isolated. Animal lectins are divided into the C-type lectins, and galectins (previously called S-type lectins) on the basis of their requirement for divalent cations (C-type) and solubility, or thiol-dependence (S-type).

Lectin type	Specificity	Metal ions
<i>Plants</i>		
Legumes	Diverse	Ca ²⁺ , Mn ²⁺
Cereals	GlcNAc, NeuAc	–
<i>Animals</i>		
C-type	Diverse	Ca ²⁺
Galectins	Gal	–

A common property of all galectins is their affinity to β -galactose and the presence of the characteristic S-type carbohydrate recognition domain (CRD). The CRDs in galectins from various mammalian and bird species share 19 invariant and 36 conserved residues.^{25,27,28} The letter S in the old name for this family of lectins was originally chosen to designate the thiol-dependence but it was shown later that at least some of the S-type lectins do not require thiol groups for activity.^{25,26} No cysteine residues in these proteins are invariant, and they all appear to be present as sulphhydryl groups rather than as disulfides.

Galectins have been isolated from many different species, and show a wide tissue distribution.²⁹ Though their biological roles remain elusive, the existence of apparently homologous lectins in some of the most primitive multicellular animals, such as sponges and nematodes,^{30,31} indicates their involvement in the essential functions for all multicellular animals.

Galectin-1 and galectin-2 (L-14 lectins)

Galectin-1 and galectin-2 are the best studied β -galactoside-binding lectins. Their approximate size is 14 kDa, though it is presumed that they form non-covalent dimers under physiological conditions. Each lectin has a single CRD, and through the expression of a truncated L-14 lectin it was shown that an almost entire polypeptide is required for the carbohydrate binding.²⁷ Generally, only one L-14 lectin was isolated from each species, but the presence of two distinct members of this family was found in chicken and humans.^{32,33} Very recently, two novel lectins of this type, galectin-5 and galectin-7, were isolated from human erythrocytes^{33a} and keratinocytes,^{33b}

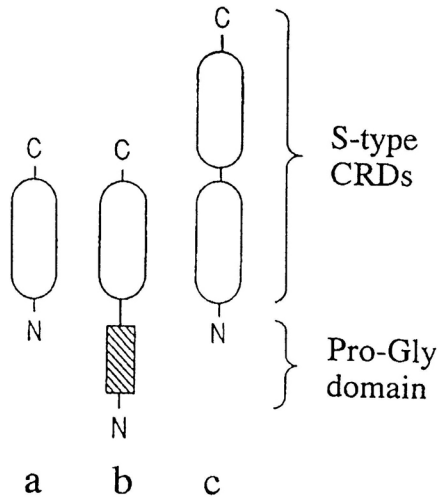

Figure 1. *Schematic structure of four galectins.* (a) galectin-1 and galectin-2 (prototype lectins) are composed exclusively of one carbohydrate recognition domain; (b) galectin-3 (chimera type lectin) consists of one lectin domain and another non-lectin, proline- and glycine-rich domain, (c) galectin-4 (tandem-repeat type lectin) contains two different lectin domains in the same polypeptide chain.

respectively. The recent finding that one previously identified L-14 lectin is in fact a proteolytic product of a larger protein with two different carbohydrate-recognition domains in the same polypeptide chain²⁶ indicates that some other L-14 lectins might also be only a part of some until now unidentified proteins.

The three-dimensional structure of the bovine spleen lectin was recently resolved at 0.19 nm resolution.^{34,34a} The overall structure reveals a surprising structural relationship to legume lectins, though no significant sequence homology exists. Two monomers associate in a dimer with a 22-strand anti-parallel β -sandwich. Two identical binding sites are located at the far ends on the same side of the β -sandwich, 4.6 nm apart.

Both galectin-1, and galectin-2 are synthesized on free ribosomes,³⁵ acetylated at the *N*-terminus, lack a secretion signal sequence and glycosylated sites, and are secreted from cells by a novel mechanism called ectocytosis, involving budding of lectin coated cytosolic vesicles from the plasma membrane.³⁶ At least part of them becomes localized at the cell surface or in the extracellular matrix.³⁷ Cells which are defective in protein glycosylation (mutant Lec8 CHO cells) do not display galectin-1 on their surfaces, suggesting its association with cell membranes through interactions with membrane glycoproteins.^{37a}

Several different functions have been proposed for galectins 1 and 2, but none of them has been convincingly proven until now. For example, these lectins can bind with high affinity to the polylectosamine structures in lamin, ³⁸ which suggests a role in cell-matrix interactions. ³⁷ Their expression is reported to be developmentally regulated. During myoblast differentiation, their localization changes from cytoplasm to the extracellular matrix, suggesting a role in cell-matrix interactions during muscle development. ³⁸ A role in cellular differentiation is also supported by the appearance of these lectins in trophoectoderm of the preimplantation blastocyst, ³⁹ in the specific subsets of central and peripheral neurons, ⁴⁰ and on thymic epithelial cells during thymocyte differentiation. ^{40a}

Galectin-3

Galectin-3 comprises a group of related lectins of 29–35 kDa, initially purified by Roff and Wang ⁴¹ from mouse fibroblast cells, and named CBP35. The same protein was soon thereafter independently discovered in several other systems: (i) Mac-2, a surface antigen of mouse macrophages; ⁴² (ii) ϵ BP, an IgE-binding protein from rat basophilic leukemia ⁴³ and HeLa cells; ⁴⁴ (iii) RL-29, and HL-29, a 29 kDa lectin from rat ⁴⁵ and human lungs, ⁴⁶ respectively; (iv) L-34, a 34 kDa metastasis-associated lectin; ⁴⁷ and (v) LBP, a major non-integrin lamin binding protein. ⁴⁸ After comparing the protein and DNA sequence data, ^{49–55} it was recognized that all these proteins are either identical (within the same species), or homologous (in different species). Whereas CBP35, L-34 and Mac-2 have apparently identical amino acid sequences, the 5' untranslated region of their mRNAs appears to differ considerably. ^{52,56,57} The presence of two differently spliced forms of mRNA, with a potential to encode proteins differing at their amino-termini, was suggested for murine galectin-3. ^{57–59} However, the significance of these differences, particularly with respect to the expression and localization of the lectin, is not known. ²⁸

Murine galectin-3 (CBP35) is composed of 264 amino acids, which are organized into two distinct structural domains. The carbohydrate recognition domain (CRD) is located within the carboxyl-terminal half of the molecule (residues 126–263). It includes a 76-residue sequence (residues 138–214) which is \approx 35% identical with several members of the L-14 group of the β -galactoside-specific lectins, and fifteen amino acid residues which are invariant in every until now sequenced L-14 or L-30 lectin. ⁵⁶ The amino-terminal half of galectin-3 (residues 1–125) includes a stretch of eight contiguous 9-residue repeat units having the sequence Pro-Gly-Ala-Tyr-Pro-Gly followed by three other residues. This stretch is, therefore, called proline/glycine-rich domain (Figure 2). Over a region comprising 107 residues, the sequence of CBP35 is approximately 25% identical with some of

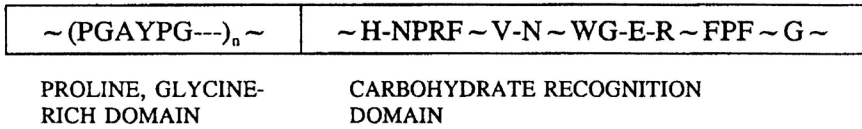

Figure 2. *Domains of galectin-3.* Galectin-3 consists of two domains: amino-terminal proline/glycine-rich domain and a carbohydrate recognition domain in the carboxyl terminal half of the molecule. The letter 'n', designating the number of repeats, ranges from five in the human Mac-2 sequence to ten in the rat ϵ BP sequence. Fifteen invariant amino acids in carbohydrate binding sites of all S-lectins are shown. A single variable residue is denoted by a hyphen '-'. Sequence of two or more variable residues is denoted by the symbol '~'.

the core proteins of hnRNP.⁵⁶ This degree of identity is similar to homology found among the hnRNP proteins themselves. Besides hnRNPs, galectin-3 shows a significant homology (33.5%) to α 1(II) chain of bovine cartilage.⁵²

In the initial isolation, lactose was identified as a specific ligand for galectin-3.⁴¹ In latter studies on L-29, it was found that introduction of an acetamido group at position 2 of glucose (*i.e.* to yield *N*-acetylglucosamine) increases the binding by nine to eleven times.⁴⁶ Lectins isolated from rats and humans had similar but, nevertheless, distinguishable specificity. In a recent detailed study using the recombinant galectin-3,⁶⁰ linear tetrasaccharide Gal- β (1,4)-GlcNAc- β (1,3)-Gal- β (1,4)-GlcNAc was identified as the most complementary ligand. As a possible organization of a carbohydrate binding site, a model composed of four subsites was suggested, with each site responsible for binding to a single monosaccharide.

Whether galectin-3 is a monomer, or it forms dimeric structures in solution, is not completely clear. Several studies reported that no evidence of dimers or other multimers could be obtained and concluded that galectin-3 is a monomeric lectin.^{41,61} However, Woo *et al.*⁵⁴ indicated that all these studies were done in a reducing environment and reported formation of dimeric structures in nonreducing solutions. Using site-directed mutagenesis, they have identified cysteine 186 as a residue responsible for formation of the cystine bond. Ochieng *et al.*⁶² also reported appearance of homo-dimeric structures at higher protein concentrations.

Positive cooperative effect, non dependent on cystine bond formation, was reported in the binding of galectin-3 to lamin and immobilized IgE ligands.^{63,64} Although not required for the binding activity, amino terminal, proline/glycine-rich domain was identified as being required for the cooperative effect. Binding of ligands to the carbohydrate binding site in the lectin domain apparently induces conformational changes in the other domain and results in formation of dimeric, or even oligomeric structures. Although the precise mechanism for oligomerization is not known, it seems that an im-

mobilized polyvalent ligand is required for the cooperative effect.⁶⁴ Some indications of the non-covalent self-association of galectin-3 in the solution, observed in cross-linking experiments,⁶³ were not supported by measurements of protein-protein interactions.⁶⁴ Moreover, the high protein concentrations used in the cross-linking experiments, and the appearance of dimeric structures even when only carboxyl-terminal (lectin) domain of galectin-3 was used,⁶⁵ imply that the observed aggregation in solution might be a cross-linking artifact.

Galectin-3 exists in the cell in two forms, *i.e.* in a phosphorylated ($pI = 8.2$) and an unphosphorylated form ($pI = 8.7$).⁶⁶ Originally, it was suggested that only one phosphate group is introduced into the galectin-3 molecule⁶⁶ but, in a recent study on L-29,⁶⁷ it was demonstrated that two phosphorylation sites exist. One is Ser-6, located in a part of the sequence that is conserved in all L-30 lectins, and another one is Ser-12. However, more than 90% of phosphate groups are located on Ser-6, and less than 10% on Ser-12.

Both phosphorylated and unphosphorylated forms of galectin-3 can be found in the cytoplasm, while only the unphosphorylated form can be found in the nucleus.^{66,68} In the nucleus, galectin-3 seems to be associated with hnRNP complexes, and it was suggested that it might be a vital part of a spliceosome.⁶⁹ The galectin-3-specific carbohydrate ligands and anti-galectin-3 monoclonal antibodies inhibited the splicing *in vitro*, while the similar, but for galectin-3 irrelevant, carbohydrates and monoclonal antibodies did not have any effect.⁷⁰ It was also suggested that galectin-3 might play some role in the transport of mRNA from the nucleus.⁷⁰ Demonstration that the addition of simple sugars might be a sufficient signal for translocation of BSA to the nucleus⁷¹ suggests another possible role of galectin-3 and other nuclear lectins, *i.e.* their involvement in the process of translocation of spliceosome components, or some other proteins, from the cytoplasm to the nucleus.

Besides in the nucleus and in the cytoplasm, galectin-3 is also present on the cell surface. Originally, this was described by a monoclonal antibody that stained the cell surface of peritoneal macrophages.⁴² Further studies suggested that galectin-3 (Mac-2) might be a differentiation marker of macrophages elicited by inflammatory stimuli, *e.g.* thioglycollate.⁵⁷ Recently, it was found that galectin-3 (ϵ BP) present on the surface of mast cells, besides IgE, binds also to Fc ϵ RI, a high-affinity IgE receptor.⁷² Based on this unique property of binding to both IgE and IgE-receptor, it was suggested that it might have an important role in regulation of the mast cell activation.⁷³

The transport mechanism of galectin-3 from the cytoplasm to the cell surface and extracellular matrix is not known. None of the cDNA clones identified until now have revealed the amino terminal signal sequence for sequestration into the lumen of the endoplasmatic reticulum and subsequent transport to the cell surface.^{28,58} It seems that galectin-3 is secreted

by an unusual mechanism that does not depend on a signal peptide.⁷³ This type of secretion was demonstrated for the mouse 14 kDa lectin during myogenesis,³⁶ and it apparently resembles the 'degranulation/exocytosis' pathway observed for some granular proteins.⁷⁴ When secreted, galectin-3 is expressed on the surface of the cell by its virtue to bind cell surface glycoconjugates.⁷⁵ Three glycoproteins with molecular masses of 92, 125, and 180 kDa containing α -galactosyl and polylectosamine structures were identified as the putative ligands.^{76,77} The minimum lipid-linked oligosaccharides that can support galectin-3 binding are pentasaccharides of the lacto/neolacto series and the lectin binds more strongly to oligosaccharides of this family bearing the blood group A, B, or B-like determinants than to those bearing blood group H determinants.^{77a}

Very recently, galectin-3 was reported to be a substrate for tissue type transglutaminase which cross-links galectin 3 to matrix components, or to itself, resulting in galectin-3 oligomers.^{77b} This might be one mechanism for the stabilization of a multivalent binding form of the lectin in cell secretions or in extracellular matrices. Nevertheless, most of galectin-3 is located intracellularly and only a small proportion could be found on the cell surface or in the extracellular medium.⁵⁷

The differentiation and proliferation state of the cell have a significant influence on the expression and intracellular distribution of galectin-3.^{28,78} Quiescent populations of 3T3 fibroblasts mostly express the phosphorylated form of galectin-3 which is located predominantly in the cytoplasm. Stimulation of the same cells into the proliferative state leads to an increase in the amount of both the phosphorylated and the unphosphorylated form of galectin-3, but the increase of the unphosphorylated galectin-3, a nuclear form which is barely detectable in quiescent cells, is striking.⁷⁹ The increase occurs early after the stimulation of cells, and well before the onset of the first cell cycle.^{80,81}

Neoplastic transformation was also found to influence the expression of galectin-3, but the results obtained by different groups are somewhat contradictory. Raz and Lotan⁸² found that the expression of galectin-3 (L-34) increases concomitantly with the neoplastic transformation of normal rat embryonal fibroblasts. The same group also found a correlation between the increased expression of galectin-3 and the progression of colorectal carcinoma.⁸³ However, another group⁸⁴ reported *decreased* levels of galectin-3 and its mRNA, as well as loss of the nuclear localization as a consequence of the neoplastic progression in the same system (colon carcinoma). The reasons for such contradictory results are not clear.

CBP67 and CBP70 are two glucose specific C-type lectins present in the cell nuclei. The first one was isolated from rat liver⁸⁵ and the second one from HL60 cell line.⁸⁶ Although preliminary results suggested that CBP67 and CBP70 are two distinct proteins,⁸⁶ recent data support the idea that

they are in fact homologous proteins.⁸⁷⁻⁸⁹ The extent of the knowledge about this protein is relatively narrow. It is associated with hnRNP complexes and it has been suggested that it might participate in the transport of mRNA from the nucleus.⁸⁵ Although originally isolated as a glucose specific protein, it was recently shown that its affinity for *N*-acetylglucosamine is twice higher than that for glucose.⁹⁰

Complex formation between galectin-3 and CBP67/70, which can be disrupted by the addition of lactose, has been reported in several recent studies.⁸⁶⁻⁸⁸ Two possible models for this interaction have been proposed: (i) based on the hypothesis that CBP67/70 is itself a glycoprotein and that the interaction occurs through the carbohydrate binding site on galectin-3; and (ii) that the interaction occurs through a protein-protein interaction which is then disturbed by a conformational change in galectin-3 after its binding to lactose. Since the galectin-3-CBP67/70 complex was retained on the lactose-affinity column, and the galectin-3 has only one carbohydrate binding site, Sève *et al.* concluded that this is inconsistent with the first model and concluded that the second model is more probable. However, considering the ability of galectin-3 to form dimers in nonreducing environment,⁵⁴ or even oligomeric structures in the presence of polyvalent ligands,^{63,64} arguments for refuting the first model do not seem to be convincing enough. Moreover, unequal amounts of galectin-3 and CBP67/70 retained on the lactose-column⁸⁶ are easier to explain with CBP67/70 bound to the oligomeric aggregate of galectin-3 than with a direct galectin-3-CBP67/70 protein-protein interaction.

We have recently reported a stress-induced change in the interaction between galectin-3 and CBP67/70.⁸⁸ Immobilization of rats seems to alter this interaction resulting in the retention of galectin-3 on a glucose affinity column. The result is copurification of galectin-3 and CBP67/70 from the livers of stressed rats. This copurification was not observed in rats which were not exposed to immobilization stress. Appearance of galectin-3 in liver extracts from stressed rats might be a reflection of a stress-induced increase in the synthesis of galectin-3, but our most recent data (unpublished results) suggest that stress does not influence the overall level of galectin-3, and advocate for a more profound stress-induced change in the regulation of the galectin-3-CBP67/70 interaction.

Galectin-4

Galectin-4, or tandem-repeat type lectins were found in the nematode *Caenorhabditis elegans*³⁰ and the rat intestine.²⁶ They contain two homologous but distinct S-type CRDs in a single polypeptide chain. The link between two lectin domains seems to be highly prone to proteolysis and the usual result of its purification are separated domains.⁹¹ The biological significance of the existence of this kind of tandem-repeat lectins is not clear.

CONCLUSIONS

In the last decade, lectinology and its complement glycobiology became one of the fastest growing fields of biochemistry. The number of articles dealing with lectins is increasing exponentially, at the current rate of approximately 1500 articles per year. In most of these studies, lectins were used only as a tool to analyze glycoconjugates but the number of articles dealing with intrinsic properties of individual lectins is also impressive.^{92,93} The galectins, a newly formed family of lectins, account for a sizable portion of that number. Their wide distribution, ranging from lower invertebrates, such as sponges and nematodes to mammals, and conservation during evolution suggest an important role of galectins in the physiology of all multicellular organisms. Complete functions of galectins may not be yet fully understood, but there is strong evidence suggesting their involvement in growth regulation, cell adhesion, cell migration, neoplasia, immune and stress response.

Acknowledgements. – The author's work is supported by grants from the Ministry of Science and Technology of the Republic of Croatia (# 1-07-102) and from Sandoz Foundation.

REFERENCES

1. W. C. Boyd, and E. Schpleigh, *Science* **119** (1954) 419.
2. I. J. Goldstein, R. C. Hughes, M. Monsigny, T. Osawa and N. Sharon, *Nature* **285** (1980) 66.
3. J. Kocurek, and V. Horejsi, *Nature* **290** (1981) 81.
4. S. Barondes, *Trends Biochem. Sci.* **13** (1988) 480.
5. H. Stillmark, *Über Ricin, ein giftiges ferment aus den samen von Ricinus comm. L. und einigen anderen Euphorbiaceen*. Doctoral thesis, University of Dorpat, Dorpat, 1888.
6. H.-J. Gabius, and S. Gabius (Eds.), *Lectins and Glycobiology*, Berlin, Springer-Verlag, 1994, pp.141–190.
7. P. C. Nowell, *Cancer Res.* **20** (1960) 462.
8. N. Sharon, and H. Lis, *Trends Biochem. Sci.* **12** (1987) 488.
9. G. M. E. Cook, *J. Cell. Sci. [Suppl.]* **4** (1986) 45.
10. R. C. Hughes, *Glycoproteins*, Chapman & Hall, London, 1983.
11. N. Sharon, and H. Lis, *Science* **246** (1989) 227.
12. L. Warren, *Bound carbohydrates in nature*, Cambridge University Press, Cambridge, 1994.
13. N. Sharon, *Complex carbohydrates: Their chemistry, biosynthesis and functions*, Addison-Wesley, Reading, 1975, p. 26.
14. K. Drickamer, *J. Biol. Chem.* **263** (1988) 9557.
15. Y. C. Lee, *Biochem. Soc. Trans.* **21** (1993) 460.
16. F. L. Harrison, and C. J. Chesterton, *FEBS Lett.* **122** (1980) 157.
17. T. Feizi, *Nature* **314** (1985) 53.
18. T. Feizi, *Trends Biochem. Sci.* **16** (1991) 84.
19. S. Barondes, *Annu. Rev. Biochem.* **50** (1981) 207.

20. H. Lis, and N. Sharon, *Annu. Rev. Biochem.* **55** (1986) 35.
21. R. Lucas, S. Magez, R. De Leys, L. Franssen, J.-P. Scheerlinck, M. Rampelberg, E. Sablon and P. De Baetselier, *Science* **263** (1994) 814.
22. G. Lauc, M. Flögel, B. Diehl-Seifert, H. C. Schröder, and W. E. G. Müller, *Glycoconjugate J.* **11** (1994) 541.
23. S. Lehmann, S. Kuchler, S. Gobaille, P. Marschal, A. Badache, G. Vincendon and J.-P. Zanetta, *Brain Res. Bull.* **30** (1993) 515.
24. S. H. Barondes, V. Castronovo, D. N. W. Cooper, R. D. Cummings, K. Drickamer, T. Feizi, M. A. Gitt, J. Hirabayashi, R. C. Hughes, K. Kasai, H. Leffler, F.-T. Liu, R. Lotan, A. M. Mercurio, M. Monsigny, S. Pillai, F. Poirer, A. Raz, P. W. J. Rigby, J. M. Rini and J. L. Wang, *Cell* **76** (1994) 597.
25. J. Hirabayashi and K. Kasai, *J. Biol. Chem.* **266** (1991) 23648.
26. Y. Oda, J. Herrmann, M. A. Gitt, C. W. Turck, A. L. Burlingame, S. H. Barondes, and H. Leffler, *J. Biol. Chem.* **268** (1993) 5929.
27. W. M. Abbot, and T. Feizi, *J. Biol. Chem.* **266** (1991) 5552.
28. J. L. Wang, J. G. Laing and R. L. Anderson, *Glycobiology* **1** (1991) 243.
29. J. Hirabayashi and K. Kasai, *Glycobiology* **3** (1993) 297.
30. J. Hirabayashi, M. Satoh, and K. Kasai, *J. Biol. Chem.* **267** (1992) 15485.
31. K. Pfeifer, M. Haasemann, V. Gamulin, H. Bretting, F. Fahrenholz and W. E. G. Müller, *Glycobiology* **3** (1993) 179.
32. Y. Sasakura, J. Hirabayashi, Y. Oda, Y. Ohyama, and K. Kasai, *J. Biol. Chem.* **265** (1990) 21573.
33. M. W. Gitt, S. M. Massa, H. Leffler, and S. H. Barondes, *J. Biol. Chem.* **267** (1992) 10601.
- 33a. M. A. Gitt, M. F. Wisner, H. Leffler, J. Herrmann, Y. R. Xia, S. M. Massa, D. N. Cooper, A. J. Lusis, and S. H. Barondes, *J. Biol. Chem.* **270** (1995) 5032.
- 33b. P. Madsen, H. H. Rasmussen, T. Flint, P. Gromov, T. A. Kruse, B. Honor'e, H. Vorum, and J. E. Celis, *J. Biol. Chem.* **270** (1995) 5823.
34. D. I. Liao, G. Kapadia, H. Ahmed, G. R. Vasta, and O. Herzberg, *Proc. Natl. Acad. Sci. USA* **91** (1994) 1428.
- 34a. Y. Bourne, B. Bolgiano, M. P. Nesa, P. Penfold, D. Johnson, T. Feizi, and C. Cambillau, *J. Mol. Biol.* **235**:787.
35. T. I. G. Wilson, M. N. Firth, J. T. Powell, and F. L. Harrison, *Biochem. J.* **261** (1989) 847.
36. F. L. Harrison, and T. J. G. Wilson, *J. Cell. Sci.* **101** (1992) 635.
37. D. N. W. Cooper, S. M. Massa, and S. H. Barondes, *J. Cell. Biol.* **115** (1991) 1437.
- 37a. M. Cho, and R. D. Cummings, *J. Biol. Chem.* **270** (1995) 5207.
38. S. Sato, and R. C. Hughes, *J. Biol. Chem.* **267** (1992) 6983.
39. M. A. Hynes, M. Gitt, S. H. Barondes, T. M. Jessell, and L. B. Buck, *J. Neurosci.* **10** (1990) 1004.
40. F. Poirier, P. M. Timmons, C. T. Chan, J. L. Guenet, and P. W. Rigby, *Development* **115** (1992) 143.
- 40a. L. G. Baum, M. Pang, N. L. Perillo, T. Wu, A. Delegeane, C. H. Uittenbogaart, M. Fukuda, and J. J. Seilhamer, *J. Exp. Med.* **181** (1995) 877.
41. C. F. Roff, and J. L. Wang, *J. Biol. Chem.* **258** (1983) 10657.
42. M. K. Ho, and T. A. Springer, *J. Immunol.* **128** (1982) 1221.
43. F.-T. Liu, and N. Orida, *J. Biol. Chem.* **259** (1984) 10649.
44. M. W. Robertson, K. Albrandt, D. Keller, and F.-T. Liu, *Biochemistry* **29** (1990) 8093.
45. R. F. Cerra, M. A. Gitt, and S. H. Barondes, *J. Biol. Chem.* **260** (1985) 10474.

46. C. P. Sparrow, H. Leffler, and S. H. Barondes, *J. Biol. Chem.* **262** (1987) 7383.
47. A. Raz, L. Meromsky, and R. Lotan, *Int. J. Cancer* **39** (1987) 353.
48. H.-J. Woo, L. M. Shaw, J. M. Messier, and A. M. Mercurio, *J. Biol. Chem.* **265** (1990) 7097.
49. K. Albrandt, N. K. Orida, and F.-T. Liu, *Proc. Natl. Acad. Sci. U.S.A.* **849** (1987) 6859.
50. J. G. Laing, M. W. Robertson, C. A. Gritzmacher, J. L. Wang, and F.-T. Liu, *J. Biol. Chem.* **264** (1989) 1907.
51. H. Leffler, F. R. Masiarz, and S. H. Barondes, *S. H. Biochemistry* **28** (1989) 9222.
52. A. Raz, G. Parerini, and P. Carmi, *Cancer Res.* **49** (1989) 3489.
53. B. J. Cherayil, S. Chaitovitz, C. Wong, and S. Pillai, *Proc. natl. Acad. Sci. U.S.A.* **87** (1990) 7324.
54. H.-J. Woo, M. M. Lotz, J. U. Jung, and A. M. Mercurio, *J. Biol. Chem.* **266** (1991) 18419.
55. A. Raz, P. Carmi, T. Raz, V. Hogan, A. Mohamed, and S. R. Wolman, *Cancer Res.* **51** (1991) 2173.
56. S. Jia, and J. L. Wang, *J. Biol. Chem.* **263** (1988) 6009.
57. B. J. Cherayil, S. J. Weiner, and S. Pillai, *J. Exp. Med.* **170** (1989) 1959.
58. I. M. Rosenberg, R. Iyer, B. Cherayil, C. Chiodino, and S. Pillai, *J. Biol. Chem.* **268** (1993) 12393.
59. P. G. Voss, Y.-G. Tsay, and J. L. Wang, *Glycoconjugate J.* **11** (1994) 353–362.
60. R. N. Knibbs, N. Agrwal, J. L. Wang, and I. J. Goldstein, *J. Biol. Chem.* **268** (1993) 14940.
61. L. G. Frigeri, M. W. Robertson, and F.-T. Liu, *J. Biol. Chem.* **265** (1990) 20763.
62. J. Ochieng, D. Platt, L. Tait, V. Hogan, T. Raz, P. Carmi, and A. Raz, *Biochemistry* **32** (1993) 4455.
63. D. K. Hsu, R. I. Zuberi, and F.-T. Liu, *J. Biol. Chem.* **267** (1992) 14167.
64. S. M. Massa, D. N. W. Cooper, H. Leffler, and S. H. Barondes, *Biochemistry* **32** (1993) 260.
65. F.-T. Liu, L. G. Frigeri, C. A. Gritzmacher, D. K. Hsu, M. W. Robertson, and R. I. Zuberi, *Immunopharmacology* **26** (1993) 187.
66. E. A. Cowles, N. Agrwal, R. L. Anderson and J. L. Wang, *J. Biol. Chem.* **265** (1990) 17706.
67. M. E. Huflejt, C. W. Turck, R. Lindstedt, S. H. Barondes, and H. Leffler, *J. Biol. Chem.* **268** (1993) 26712.
68. I. K. Moutsatsos, J. M. Davis, and J. L. Wang, *J. Cell Biol.* **102** (1986) 477.
69. J. G. Laing, and J. L. Wang, *Biochemistry* **27** (1988) 5327.
70. J. L. Wang, E. A. Werner, J. L. Laing, and R. J. Patterson, *Biochem. Soc. Trans.* **20** (1992) 269.
71. E. Duverger, V. Carpentier, A.-C. Roche, and M. Monsigny, *Exp. Cell Res.* **207** (1993) 197.
72. L. G. Frigeri, R. I. Zuberi, and F.-T. Liu, *Biochemistry* **32** (1993) 7644.
73. F.-T. Liu, *Immunol. Today* **14** (1993) 486.
74. H. H. Butterfield, S. J. Ackerman, R. E. Scott, R. V. Pierre, and G. J. Griech, *Exp. Hematol.* **12** (1984) 163.
75. L. G. Frigeri, and F.-T. Liu, *J. Immunol.* **148** (1992) 861.
76. S. Sato, and R. C. Hughes, *J. Biol. Chem.* **269** (1994) 4424.
77. S. Sato, and R. C. Hughes, *Eur. J. Immunol.* **24** (1994) 216.
- 77a. T. Feizi, J. C. Solomon, C. T. Yuen, K. C. Jeng, L. G. Frigeri, D. K. Hsu, and F. T. Liu, *Biochemistry* **33** (1994) 6342.

- 77b. B. Mehul, S. Bawumia, and R. C. Hughes, *FEBS Lett.* **360** (1995)160.
78. P. NangiaMakker, J. Ochieng, J. K. Christman, and A. Raz, *Cancer Res.* **53** (1993) 5033.
79. E. A. Cowles, I. K. Moutsatsos, J. L. Wang, and R. L. Anderson, *Exp. Gerontol.* **24** (1989) 577.
80. I. K. Moutsatsos, M. Wade, M. Schindler, and J.L. Wand, *Proc. Natl. Acad. Sci. U.S.A.* **84** (1987) 6452.
81. N. Agrwal, J. L. Wang, and P. G. Voss, *J. Biol. Chem.* **264** (1989) 17236.
82. A. Raz, and R. Lotan, *Cancer Metastasis Rev.* **6** (1987) 433.
83. T. Irimura, Y. Matsushita, R. C. Sutton, D. Carralero, D. W. Ohannesian, K. R. Clearly, D. M. Ota, G. I. Nicolson, and R. Lotan, *Cancer Res.* **51** (1991) 387.
84. M. M. Lotz, C. W. Andrews, Jr., C. A. Korzelius, E. C. Lee, G. D. Steele, A. Clarke, and A. M. Mercurio, *Proc. Natl. Acad. Sci. U.S.A.* **90** (1993) 3466.
85. H. C. Schröder, P. Facy, M. Monsigny, K. Pfeifer, A. Bek, and W. E. G. Müller, *Eur. J. Biochem.*, **205** (1992) 1017.
86. A. P. Sève, M. Felin, M. A. DoyennetteMoyne, T. Sahraoui, M. Aubery, and J. Hubert, *Glycobiology*, **3** (1993) 2330.
87. A.-P. Sève, Y. Hadj-Sahaoui, M. Felin, M.-A. Doyennette-Moyne, M. Aubery, and J. Hubert, *Exp. Cell. Res.*, **213** (1994) 191.
88. G. Lauc, A.-P. Sève, J. Hubert, M. Flögel, W. E. G. Müller, and H. C. Schröder, *Mech. Age. Dev.* **70** (1993) 227.
89. H. C. Schröder, G. Lauc, A.-P. Sève, J. Hubert, M. Flögel, and W. E. G. Müller, *Z. Gerontol.* **27** (1994) 200.
90. M. Felin, M.-A. Doyennette-Moyne, Y. Hadj-Sahraoui, M. Aubery, J. Hubert, and A.-P. Seve, *J. Cell. Biochem.*, in press.
91. F. Tardy, P. Deviller, P. Louisot, and A. Martin, *FEBS Lett.* **359** (1995) 169.
92. D. H. Gauss, *Lectins: Insights into the state of knowledge by literature searches*, in H.-J. Gabius, and S. Gabius (Eds.), *Lectins and Glycobiology*, Berlin, Springer-Verlag, 1994, pp.3-5.
93. K. Drickamer, and M. E. Taylor, *Annu. Rev. Cell Biol.* **9** (1993) 237-264.

SAŽETAK

Lektinologija: novo biokemijsko područje

Gordan Lauc i Mirna Flögel

Lektini se definiraju kao proteini koji vežu ugljikohidrate, a nisu enzimi niti protutijela. Do nedavno lektini su smatrani isključivo biljnim proteinima i kao takvi su privlačili samo ograničenu pozornost biokemičara. Nakon otkrića lektina u životinjskim stanicama i spoznavanja njihove uloge u ključnim procesima kao što su razvoj, diferencijacija i neoplastička transformacija, počela su intenzivna istraživanja njihove specifičnosti, strukture, smještaja i biološke funkcije.

Nekoliko lektina koji specifično prepoznaju β -galaktozu nedavno je organizirano u novu obitelj lektina – *galektine*. Članovi ove obitelji prisutni su u gotovo svim životinjama od nižih avertebrata do sisavaca, uključivši i čovjeka. Iako fiziološka uloga galektina još uvijek nije dovoljno razjašnjena, svijest o njihovoj važnosti razvija se usporedno sa spoznavanjem njihovih svojstava, interakcija i mogućih primjena.