

SENSORS AND THEIR CLASSIFICATION IN THE FUSION WELDING TECHNOLOGY

Ivica Garašić, Zoran Kožuh, Maja Remenar

Subject review

In this paper the most commonly used sensing systems in modern welding industry, which nowadays includes robotic systems, are listed and analysed. According to mechanisms of action and measured parameters, several classifications of sensor systems are presented. MIG/MAG, resistance and laser beam welding processes are the most commonly robotized ones in the industry and therefore special attention is given to them. Several characteristics, limitations and advantages of sensor systems are presented and mechanisms of action are briefly described.

Keywords: sensors; sensors for geometrical parameters; sensors for technological parameters; through-arc sensing; welding

Senzori i njihova podjela u tehnologiji zavarivanja

Pregledni članak

U radu su navedeni i opisani najčešće korišteni senzorski sustavi u suvremenoj zavarivačkoj industriji koja u današnje vrijeme podrazumijeva robotizirane sustave. Predstavljene su podjele senzora u ovisnosti o mehanizmima djelovanja te mjerenim parametrima, a prvenstveno se pozornost posvetila robotiziranim postupcima zavarivanja (MIG/MAG, elektrootporno i lasersko zavarivanje). Ukratko su objašnjeni mehanizmi djelovanja pojedinih senzorskih sustava skupa s njihovim mogućim ograničenjima, prednostima ili specifičnostima.

Ključne riječi: elektrolučni senzori; geometrijski senzori; senzori; tehnološki senzori; zavarivanje

1 Introduction

The demand for better control and sensing in welding has increased with automation and welding processes involving new and advanced materials. This requires precise control of the welding process to produce the desired weld with respect to productivity and quality. Consequently, there is a need for different technologies to control precisely the process with respect to the different welding operating parameters. In doing so, sensors play a crucial role as the major source of input to the control system that manage and control the behaviour and output of the welding system.

Generally speaking, most robotized welding processes that produce a continuous weld are based on the MIG/MAG process. Within this application field, the use of sensors has been modest. The development of new products makes use of new materials with possibilities to decrease thicknesses. A result of this is a need to be able to work with tighter tolerances. Thus, the need is increasing for sensors that can meet the new processes requirements and product specifications.

The main task of the sensors is to provide the control system with information to generate proper actions to produce a result that corresponds with defined specifications. From a welding process perspective, the process is done mainly by two subsystems. The first one is the welding equipment subsystem (welding power source, wire feed system, conduit, welding torch ...) and the second one is the robot subsystem (robot produces the relative positioning of the weld torch). Depending on different criteria, few classifications of sensors are today in use. Fig. 1 shows the sensor classification according to [1].

According to [2], sensory technology can be divided into:

- Wire touch sensing - after applying a sensing voltage to the weld wire, the robot is programmed to move to a series of positions relative to the weld joints. The tool point position is recorded when the wire touches the part and the voltage drops to zero. After a series of touches, the original program is adjusted [3].
- Through-arc sensing - the robot is programmed to weave the arc across the weld joint which results in a current and voltage change in the weld power supply. The robot controls offsets in the programmed trajectory to bring the weld current back to a specified level [3].
- Vision-guided line scan systems - a laser camera is mounted on a defined distance ahead of the weld torch. An accurate position of the weld, down to 0.1 mm, and process variables such as gap and joint angles, are measured [4].
- Vision guided circular systems - using a circular scan rather than a line scan, three-dimensional data can be obtained from a single measurement. Usually this method is slower than the line scan system mentioned above.

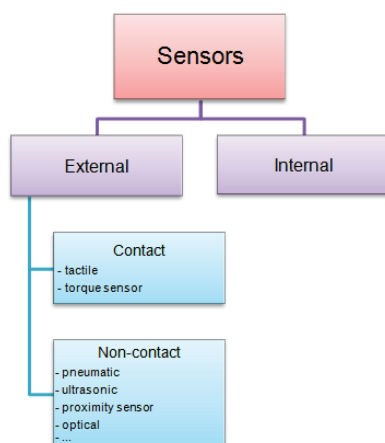

Figure 1 Classification of sensors according to [1]

Fig. 2 shows the sensor classification according to [2].

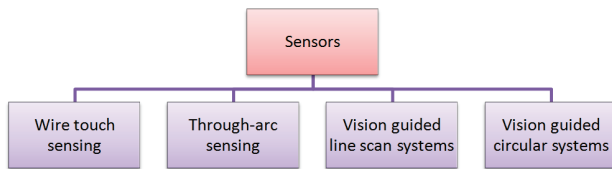

Figure 2 Classification of sensors according to [2]

According to [5] the purpose of the sensor and how it will be used will affect the specification of the sensor which therefore can be divided into two groups, technological and geometrical sensors (Fig 3). Sensors that measure geometrical parameters are mainly used to provide the robot with data necessary for the seam tracking to be done. This allows the pre-programmed path of the robot to be altered according to geometrical deviations. Technological sensors measure parameters within the welding process for its stability and are mostly used for monitoring and/or controlling purposes.

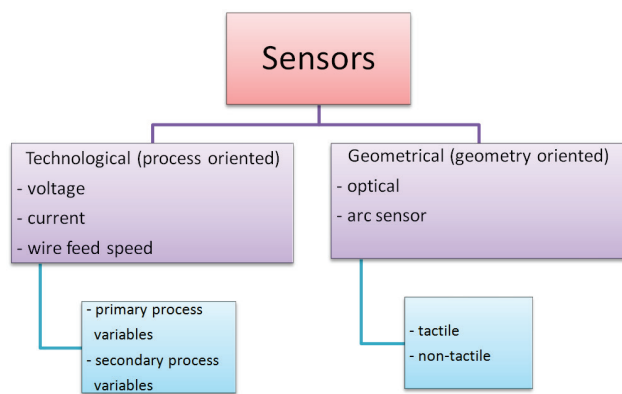

Figure 3 Classification of sensors according to [5]

The use of sensors in the welding industry is proportional to the process quality demand. If the welding process provides good quality products with a low cost and simple control unit accompanied with less usage of sensors, the defined elements represent the optimal choice for the given process.

Along with resistance welding, MIG/MAG welding is the most commonly robotized welding process in industry. The reason for such high robotization of the process is its wide use in the industry and also its suitability for implementation in robotized welding cells.

2 Sensors for technological parameters

In this section sensors that measure technological parameters including voltage, current and wire feed speed are reviewed.

2.1 Arc voltage

The measurement of the arc voltage should be made as close to the welding arc as possible. The current is delivered to the wire at the contact tube and this location is assumed to be a good measuring point. However, there is a voltage drop between the contact tube and the wire tip where the arc starts of about 0,3 V, depending on the process characteristics [6]. In practice, it is extremely difficult in a production environment, to measure the true

arc voltage. This is also the case for measuring the voltage at the contact tube in the weld torch, and a better and more reliable way is to measure the voltage on the wire inside the wire feeding system. It must be noted that measurements are made within an environment that uses high currents, usually in the range of 150 ÷ 500 A. In that case if wires used for sensors are placed in the wrong way, this can result in substantial induced voltages with corresponding reading errors.

2.2 Welding current

There are two types of sensors for measuring the welding current: Current Shunt and Hall Effect.

- Current Shunt - the principle is to let the current flow through a resistor and measure the voltage drop across it. The major drawback of this method is that the resistor must be kept low (hence the voltage signal measured will be small and sensitive to noise).
- Hall Effect sensor – it consists of a circular core of cast iron through which the cable that carries the current flows. The device itself is placed in the gap in the iron core which in turn consists of a doped silicon plate with two pairs of connecting cables. The first pair of cables feeds the device with a current. Afterwards the device responds by delivering a signal on a second pair of cables (which is proportional to the magnetic field and thereby the current). The main benefit of the Hall Effect device is that it is a non-contact sensor and does not interfere with the current of the welding power source. The sensor is limited in band width which is usually in the order of 100 kHz or more and a typical slew rate is 50 A/μs.

2.3 Wire feed speed

The wire feed speed is a major parameter to control in order to achieve a stable welding process. The welding power source is in most cases controlled to produce a constant voltage and the preset parameters are usually voltage and current. However, in reality, a current will represent a certain wire feed speed and the common method is to apply a constant value of voltage and wire feed speed and let the current adjust itself accordingly. By keeping the wire feed speed at a nominal preset value a stable welding process can be achieved.

In normal robot systems, the wire feed unit is mounted on the robot arm. However, in some cases, longer conduits must be used what result in wire can feed speed variations when the conduit is bent and twisted. In practice, a push-pull wire feed system should be used to counteract this problem. Measuring the wire feed speed is a major issue and for laboratory purposes custom-made solutions can be build that measure the speed at the contact tube. A more realistic approach in a production system is to measure the controlled speed of the drive wheel of the feeder unit. However, this must be complemented with securing the functionality and reliability of the feeder system as its robustness is important for the resulting quality of the welds.

3 Sensors for geometrical parameters

Sensors for geometrical parameters must be able to obtain information about the weld that relates to the geometry of the weld joint. This information is of great importance in order for the seam tracking to be done and use this information for quality control of the weld.

The challenge, however, is to use sensors during welding. Due to the harsh environment with high temperature, liquid metal spattering, intensive light and high currents, purpose built sensors must be applied. The most commonly used sensors are optical and through-arc sensors.

3.1 Optical sensors

Optical sensors use the following basic principle for detecting the weld joint during arc welding. A laser beam that is projected in a scanning motion across the seam (a) and a CCD-array that is used to measure features of the weld joint in combination with a laser stripe (b). Variations of this method are in use (for example: the laser stripe may not be a linear line on the weld joint but circular instead). In such a case, the sensor is more flexible to detect weld joints in corners. To measure the distance, the method of triangulation is used (Fig. 4).

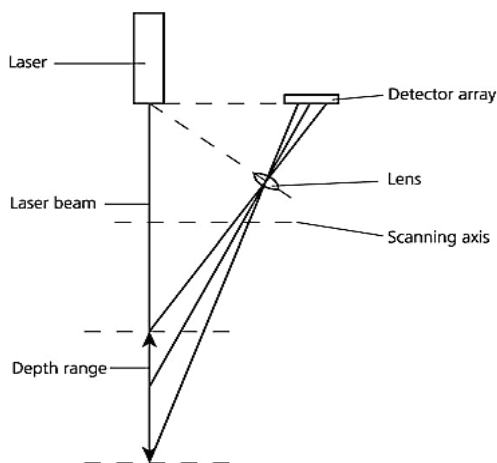

Figure 4 The working principle of the triangulation method [5]

A laser beam is focused on an object, and then the reflection from the object as seen from a lens in the laser sensor is determined by the distance between the sensor and the object. If the object is close to the sensor then the angle between the outgoing beam and the reflection through the focusing lens of the detector is large, while it is small if the object is farther away.

Depending on the weld joint preparation and geometrical shape, the laser beam can produce reflections like mirrors. Consider for example a V-groove weld joint where the laser light will produce several reflecting positions but with different intensities depending on the surfaces of the weld joint. Therefore, these sensors must have real time image processing capabilities to filter out reflections that do not belong to the point of interest. It should be noted in this context that highly reflective materials may cause problems during welding and a real test may be needed to verify the functionality.

The general use of triangulation in welding is for seam tracking and this requires measuring the weld joint geometry. This is achieved through a scanning technique of the beam across the weld joint (Fig. 5). During the scanning, the sensor acquires a two-dimensional picture of the joint profile as an array of 2D coordinates. When the robot is moving, a weld joint geometrical model can be made that contains a full 3D description of the joint.

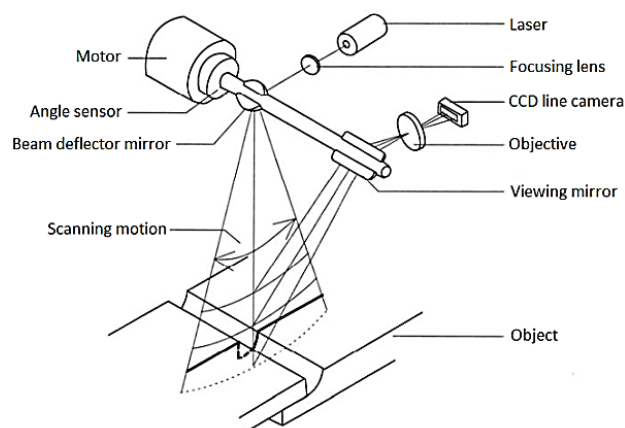

Figure 5 Scanning principle of a seam tracking combined with the triangulation method [5]

These optical sensors have a capability for more than seam tracking. Information that they acquire includes joint volume, gap size, misalignment, tack welds, etc. This information is useful for adaptive feed-back control of both the welding power source and the robot.

From a control point of view, seam tracking is usually done with full compensation of the position error measured and is typically only done using a nominal path. The nominal path is the assumed trajectory of the weld joint and during tracking the robot controller receives new target positions from the sensor. The robot controller then overrides the nominal path by changing the position of the TCP (Tool Centre Point) while keeping a constant orientation. The benefits of this method are that, given a nominal path, it is rather straightforward to verify the ability of the robot to follow the path with some minor changes while keeping the orientation constant. Drawbacks are that the user must define and program a nominal path.

If, instead, the robot is only instructed where to start and where to end, it must be able to follow the path measured by the sensor on the fly. This puts some additional requirements on the robot system as it must be able to calculate the trajectory including both target positions and orientations of the weld torch.

Typical operating data of a laser scanner is a scan sweep frequency of 10 ÷ 50 Hz. If we assume a welding speed of 1,2 m/min, this means about one sweep per mm during welding. This is in most cases more than sufficient. However, new welding processes such as laser welding will increase the welding speed considerably and for high requirements careful analysis and trials must be made.

From a practical point of view, laser scanners are accurate and robust sensors that meet most requirements within the welding process. However, they must be mounted on the weld torch and take up some space (Figs.

6 and 7). They also put additional requirements on programming and positioning of the robot and the weld torch. Laser scanning sensors are also still relatively expensive and if alternative methods can be used (like through-arc sensing), they are usually preferred [5].

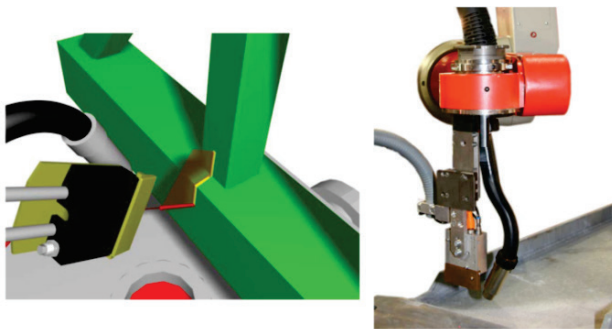

Figure 6 One-dimensional laser sensor [7]

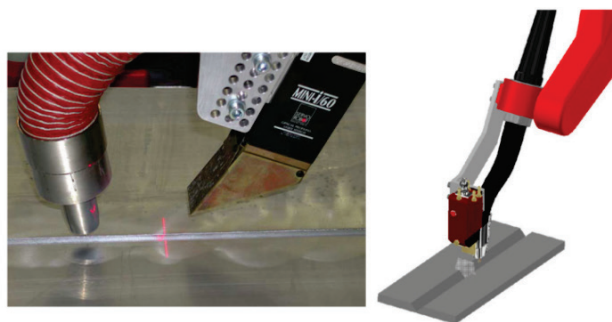

Figure 7 Two-dimensional laser sensor [7]

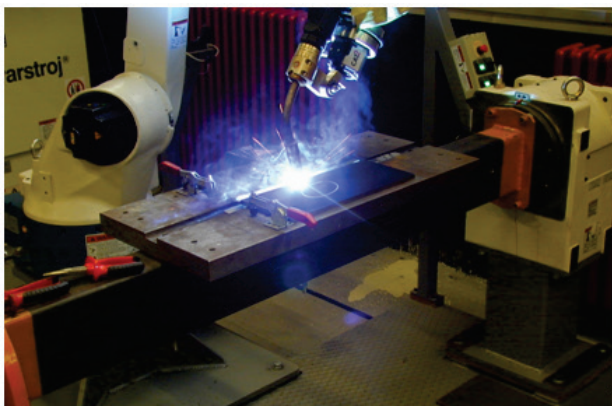

Figure 8 Robotic arc welding; arc sensor seam tracking

3.2 Arc sensors

The first basic thing to achieve with a fully automatic robotic welding system is the capability to follow precisely the joint to be welded. This is because the welding quality depends very much on the welding pool position apart from its geometry. A pre-programmed path cannot be obtained with the desired precision, since deviations from the programmed path are likely to occur due to deficient path definition. This is also due to material plate deficiencies and to the effect of heating the plates. Consequently, an on-line joint recognition and seam tracking system must be available. Several techniques have been used for joint detection and seam tracking, namely for welding robotic systems. Using the arc characteristics exploiting the proportional relationship between the welding current and the distance from the

electrode to the work-piece, as proposed by Cook [8], was one of the first approaches (Fig. 8).

Seam tracking using a weaving motion and the arc itself as the sensor, sometimes referred to as through-arc sensing, was introduced in the 1980s. The principle behind the method is to make use of the change in current when the distance between the contact tube and the work-piece varies. The underlying principle is relatively easy and cost-effective. Therefore it is a very commonly used sensor for tracking methods in robotic welding based on gas metal arc welding and related processes, like flux-cored arc welding, submerged arc welding, etc. According to [9], the approximate relationship between arc voltage (U), arc current (I) and the contact tube to work-piece distance (l) is expressed by:

$$U = \beta_1 I + \beta_2 + \frac{\beta_3}{I} + \beta_4 l \quad (1)$$

The constants β_1 , β_2 , β_3 and β_4 are dependent on factors like wire, gas and the characteristics of the welding power source. As can be seen from the equation above, when the value l varies, the arc current will also change, mainly as a proportional change with opposite sign. This can be used in mechanized welding and specifically in robotized welding to perform a weaving motion during welding. Fig. 9 shows the weaving motion of the welding torch.

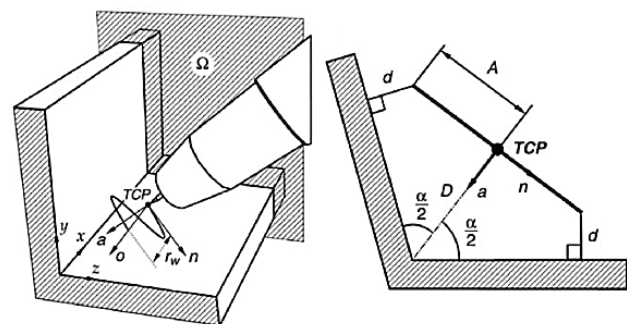

Figure 9 Direction and orientation of the welding gun during welding [5]; TCP – Tool Center Point; a – tip of the tool axis; o – direction of motion axis; n – normal axis on tool axis; r_w – weave width; d – nozzle tip to work-piece distance (on the edges); D – nozzle tip to work-piece distance (in the centre); A – weaving amplitude; Ω – vertical plane with respect to direction of motion.

If there are no deviations from the nominal path, the value of the current in the middle of the weaving motion should be equal to the reference value (the difference between the two of the current values at the edges should be zero, Fig. 10). In case of deviation of the nominal path from the central joint axis, the value of the current in the centre of weaving motion exceeds reference value implying to the smaller distance between the torch tip and work-piece. Every other point on the weaving path will also have current values different from those in the case of nominal weaving path. Based on this information, the control unit generates new welding path.

The information acquired from through-arc sensing can be retrieved and used in basically two different ways. One of them is continuous measurement of the current and the other are measurements at the turning points of the weaving motion. If a height control is included, a measurement should take place at the centre of the weld joint as well.

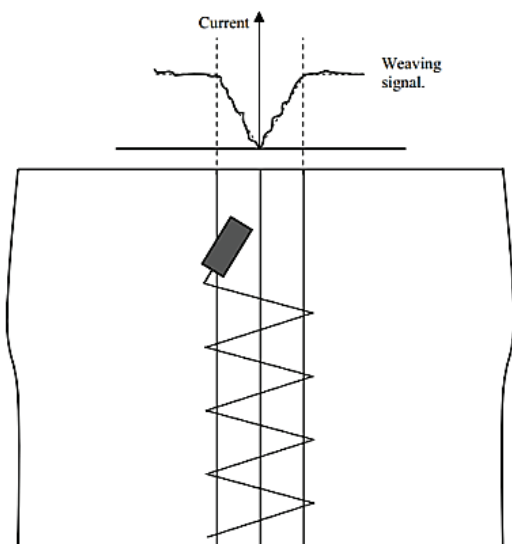

Figure 10 Welding current drop during weaving [5]

In order to achieve greater sensitivity and faster response from arc sensors, different variations are developed. The rotating-arc torch is a development for overcoming the shortcomings of the oscillating-arc torch (weaving torch). One of the variations of the rotating-arc torch is based on the mechanical, and the other on the electromagnetic oscillating mechanism [10]. Source [10] describes an electromagnetic rotating arc sensor for narrow gap welding. In spite of such a demanding environment, unified penetration on both grooves was achieved in combination with feedback information needed for seam tracking. An example of rotating arc sensor is given in [11] where it is indicated that the sensor was able to scan the end points of fillet weld.

Because of great number of advantages, arc sensors are the most commonly used sensors. For implementing arc sensor technology, no additional sensors are needed which makes them a very simple and cost efficient technology. Furthermore, it is possible to implement them into closed loop systems, and in comparison to vision systems, they are fast [12]. Also, arc sensor technology is a non-contact method and therefore it does not intervene with the welding process.

Some of the sensors that are also being used are: temperature, ultrasonic and acoustic sensors.

4 Other sensors

Measuring of temperature is possible by contact (thermocouples) or non-contact (thermo vision camera or infrared thermometer) method. Main drawback for using thermocouples is the fact that it is necessary to maintain constant contact with the work piece during welding. When using an infrared thermometer the question of uneven surface thermal emission becomes an issue. But then again, infrared thermometers have a faster response (than thermocouples) what makes it possible to implement them in a real time closed loop system [13]. In [14, 16 ÷ 19] it is possible to find research data on contact and non-contact measurement of weld penetration depth. Regardless of the method being used, heat exchange model has a major influence. According to that, accuracy of the sensor system depends on the sensors themselves

and the thermo model designed. In order to achieve a precise thermo model, impact factors like work piece thickness, thermal conductivity, material composition etc. have to be defined in advance [15]. These sensors are also used for discontinuity detection [20], seam tracking [21] and for cooling rate measurement [22, 23].

Far back in the 1970's research on the acoustic emission of the electric arc has started [24]. The basic principle is that the sound changes along with arc power oscillation [25]. Oscillation in arc power can be caused by changes in welding speed, shielding gas flow, current, voltage etc.

Acoustic signals can also be used to determine the metal transfer mode during welding process [26]. The main characteristic being used for determination of the short arc metal transfer mode is the sound of re-ignition of the arc [27].

Ultrasonic testing of welds is a proven and efficient method for detection of defects, irregularities, cracks, inclusions and other welding defects. The advantages of this method are that this is a method applicable on all materials and there is also a possibility of detecting very small irregularities. Few articles [28 ÷ 31] are describing the use of ultrasonic equipment in process control system which is more and more often being used in the industry. But in order to maximize the advantages of this method in production systems, it is necessary to develop non-contact probes which would emit and receive reflected ultrasound waves. One of the possible solutions is presented in [32, 33]. As with every other sensor, when using an ultrasonic sensor its motion has to be synchronised with the motion of the robotic hand/welding gun. It is also very important to pay attention to different thermo gradients within the heat affected zone (HAZ) because it is possible that they could reflect ultrasound waves and in that way limit the quality and accuracy of sensing.

5 Conclusion

The demand for better control and sensing in welding has increased with automation and welding processes involving new and advanced materials. In such modern production systems, sensors are becoming an irreplaceable component of the system. The main task of the sensors is to provide the control system with information to generate proper actions to produce a result that corresponds with defined specifications. Depending on different criteria, few classifications of sensors are today in use. The one most commonly in use is the one according to the object of the measurement and can therefore be divided into two groups, technological and geometrical sensors. Sensors that measure geometrical parameters (optical and arc sensors) are mainly used to provide the robot with data to perform seam tracking. Technological sensors measure parameters within the welding process (arc current and voltage, wire feed speed) for its stability and are mostly used for monitoring and/or controlling purposes. Arc sensor as an economical, simple and non-contact sensor, is the most commonly used sensor system in GMAW and FCAW welding technologies [5]. Some other sensors that are currently in used are: temperature, acoustic and ultrasonic sensors.

6 References

- [1] Gupta, A. K.; Arora, S. K. *Industrial Automation and Robotics*. Laxmi Publications, New Delhi, 2007.
- [2] Cederberg, P. *On Sensor-Controlled Robotized One-off Manufacturing*, doctorate, Lund University, Sweden, 2004.
- [3] McHaney, B. *Automated welding for job shops*. The Fabricator. 2001 <http://www.thefabricator.com/article/automationrobotics/automated-welding-for-job-shops/>. (22.10.2013)
- [4] Olsson, M. *Simulation and execution of autonomous robot systems*, doctorate, Lund University, Sweden 2002.
- [5] Norberto Pires, J.; Loureiro, A.; Böllmsjö, G. *Welding robots: technology, system issues and applications*. Springer-Verlag, Germany, 2006.
- [6] Adolfsson, A. *Automatic Quality Monitoring in GMA Welding using Signal Processing Methods*, doctorate, Lund University, Sweden, 1998.
- [7] One and two-dimensional laser sensor examples. http://www.igm-france.com/?page_id=28. (8.12.2011)
- [8] Cook, G. E. Robotic arc welding: research in sensory feedback control. // *IEEE Transactions on Industrial Electronics*. 30, 3(1983), pp. 252-268. DOI: 10.1109/TIE.1983.356736
- [9] Cook, G. E.; Andersen, K.; Fernandez, K. R.; Shepard, M. E.; Wells Jr, A. M. Electric arc sensing for robot positioning control. *Robotic Welding*. IFS Publications Ltd., UK, pp. 181-216.
- [10] Kang, Y. H.; Na, S. J. Characteristics of welding and arc signal in narrow groove gas metal arc welding using electromagnetic arc oscillation // *Welding Journal*. 82, 5(2003), pp. 93-99.
- [11] Yoo, W. S.; Shi, Y. H.; Kim, J. T.; Na, S. J. End point detection of fillet weld using mechanized rotating arc sensor in GMAW // *Welding Journal*. 85, 8(2006), pp. 180-187.
- [12] Wang, J. Y.; Mohanamurthy, P. H.; Foong, M. K.; Devanathan, R.; Chen, X. Q.; Chan, S. P. Development of a Closed-loop Through-the-Arc-Sensing Controller for Seam Tracking in Gas Metal Arc Welding. // *Proceedings of the Fifth International Conference on Control, Automation, Robotics, Vision / Singapore*, 1998, pp. 20-24.
- [13] Doebelin, E. O. *Measurement Systems: Application and Design*. McGraw-Hill, New York, 1983.
- [14] Song, J. B.; Hardt, D. E. Closed-loop control of weld pool depth using a thermally based depth estimator. // *Welding Journal*. 72, 10(1993), pp. 471-478.
- [15] Bates, B. E.; Hardt, D. E. A real-time calibrated thermal model for closed-loop weld bead geometry control. // *Transactions of the ASME: Journal of Dynamic Systems, Measurement, and Control*. 107, 1(1985), pp. 25-33. DOI: 10.1115/1.3140703
- [16] Farson, D.; Richardson, R. W.; Li, X. Infrared measurement of base metal temperature in gas tungsten arc welding. // *Welding Journal*. 77, 9(1998), pp. 396-401.
- [17] Banderjee, P.; Govardhan, S.; Wikle, H. C.; Liu, J. Y.; Chin, B. A. Infrared sensing for on-line weld geometry monitoring and control. // *Transactions of the ASME: Journal of Engineering for Industry*. 117, 3(1995), pp. 323-330.
- [18] Chen, W.; Chin, B. A. Monitoring joint penetration using infrared sensing techniques. // *Welding Journal*. 69, 4(1990), pp. 181-185.
- [19] Beardsley, H. E.; Zhang, Y. M.; Kovacevic, R. Infrared sensing of full penetration state in gas tungsten arc welding. // *International Journal of Machine Tools & Manufacture*. 34, 8(1994), pp. 1079-1090. DOI: 10.1016/0890-6955(94)90014-0
- [20] Chin, B. A.; Madsen, N. H.; Goodling, J. S. Infrared thermography for sensing the arc welding process. // *Welding Journal*. 62, 9(1983), pp. 227-234.
- [21] Nagarajan, S.; Chen, W. H.; Chin, B. A. Infrared sensing for adaptive arc welding. // *Welding Journal*. 68, 11(1989), pp. 462-466.
- [22] Lukens, W. E.; Morris, R. A. Infrared temperature sensing of cooling rates for arc welding control. // *Welding Journal*. 61, 1(1982), pp. 27-32.
- [23] Einerson, C. J.; Smartt, H. B.; Johnson, J. A.; Taylor, P. L.; Moore, K. L. Development of an intelligent system for cooling rate and fill control in GMAW. // *International Trends in Welding Science and Technology, Proceedings of the 3rd International Conference on Trends in Welding Research / Tennessee, USA, 1992*, pp. 853-857.
- [24] Jolly, W. D. Acoustic emission exposes cracks during welding. // *Welding Journal*. 48, 1(1969), pp. 21-27.
- [25] Drouet, M. G.; Nadeau, F. Pressure waves due to arcing faults in a substation. // *IEEE Transactions on Power Apparatus and Systems*. PAS-98, 5(1979), pp. 1632-1635. DOI: 10.1109/TPAS.1979.319480
- [26] Johnson, J. A.; Carlson, N. M.; Smartt, H. B. Detection of metal-transfer mode in GMAW. // *Recent Trends in Welding Science and Technology, Proceedings of the 2nd International Conference on Trends in Welding Research / Tennessee, USA, 1989*, pp. 377-381.
- [27] Grad, L.; Grum, J.; Polajnar, I.; Slabe, J. M. Feasibility study of acoustic signals for on-line monitoring in short circuit gas metal arc welding. // *International Journal of Machine Tools & Manufacture*. 44, 5(2004), pp. 555-561. DOI: 10.1016/j.ijmachtools.2003.10.016
- [28] Hardt, D. E.; Katz, J. M. Ultrasonic measurement of weld penetration. // *Welding Journal*. 63, 9(1984), pp. 273-281.
- [29] Fenn, R. Ultrasonic monitoring and control during arc welding. // *Welding Journal*. 64, 9(1985), pp. 18-22. DOI: 10.1080/10589758508952913
- [30] Carlson, N. M.; Johnson, J. A. Ultrasonic sensing of weld pool penetration // *Welding Journal*. 67, 11(1988), pp. 239-246.
- [31] Carlson, N. M.; Johnson, J. A.; Kunerth, D. C. Control of GMAW: Detection of discontinuities in the weld pool. // *Welding Journal*. 69, 7(1990), pp. 256-263.
- [32] Graham, G. M.; Ume, I. C. Automated system for laser ultrasonic sensing of weld penetration. // *Mechatronics*. 7, 8(1997), pp. 711-721. DOI: 10.1016/S0957-4158(97)00031-7
- [33] Kita, A.; Ume, I. C. Measuring on-line and off-line noncontact ultrasound time of flight weld penetration depth. // *Welding Journal*. 86, 1(2007), pp. 9-17.

Authors' addresses

Doc. dr. sc. Ivica Garašić, dipl. ing.

University of Zagreb
Faculty of Mechanical Engineering and Naval Architecture
Ivana Lučića 5, 10000 Zagreb, Croatia
E-mail: ivica.garasic@fsb.hr

Prof. dr. sc. Zoran Kožuh, dipl. ing.

University of Zagreb
Faculty of Mechanical Engineering and Naval Architecture
Ivana Lučića 5, 10000 Zagreb, Croatia
E-mail: zoran.kozuh@fsb.hr

Maja Remenar, mag. ing. mech.

University of Zagreb
Faculty of Mechanical Engineering and Naval Architecture
Ivana Lučića 5, 10000 Zagreb, Croatia
E-mail: maja.remenar@fsb.hr