

UDK 902
ISSN 1330-0644
VOL 32/2015.
ZAGREB, 2015.

Prilozi

Instituta za arheologiju u Zagrebu

Pril. Inst. arheol. Zagrebu, 32/2015
Str./Pages 1-300, Zagreb, 2015.

Izdavač/*Publisher*
INSTITUT ZA ARHEOLOGIJU
INSTITUTE OF ARCHAEOLOGY

Adresa uredništva/*Address of the editor's office*
Institut za arheologiju/*Institute of archaeology*
HR-10000 Zagreb, Ulica Ljudevita Gaja 32
Hrvatska/*Croatia*
Telefon/Phone ++385/(0)1 61 50 250
Fax ++385(0)1 60 55 806
e-mail: urednistvo.prilozi@iarh.hr
<http://www.iarh.hr>

Glavni i odgovorni urednik/*Editor in chief*
Marko DIZDAR

Uredništvo/*Editorial board*
Marko DIZDAR, Snježana KARAVANIĆ, Viktória KISS (Budapest, HUN) (prapovijest/Prehistory),
Marija BUZOV, Goranka LIPOVAC VRKLJAN (antika/Antiquities), Katarina Katja PREDOVNIK
(Ljubljana, SLO), Tajana SEKELJ IVANČAN (srednji vijek/Middle Ages), Natascha MEHLER
(Wien, AUT), Juraj BELAJ, Tatjana TKALČEC (kasni srednji vijek i novi vijek/Late Middle Ages
and Modern era), Predrag NOVAKOVIĆ (Ljubljana, SLO) (metodologija/Methodology)

Izdavački savjet/*Editorial advisory board*
Dunja GLOGOVIĆ (Zagreb), Ivor KARAVANIĆ (Zagreb), Timotej KNIFIC (Ljubljana,
SLO), Laszlo KÓVACS (Budapest, HUN), Kornelija MINICHREITER (Zagreb),
Mladen RADIĆ (Osijek), Aleksandar RUTTKAY (Nitra, SK), Ivančica
SCHRUNK (Minneapolis, USA), Željko TOMIČIĆ (Zagreb), Ante UGLEŠIĆ (Zadar)

Prijevod na engleski/*English translation*
Jadranka BOLJUNČIĆ, Stašo FORENBAHER, Sanjin MIHELIĆ, Ákos PETŐ, Marta RAKVIN
Anita RAPAN PAPEŠA, Mladen TOMORAD, Ivan VALENT

Prijevod na hrvatski/*Croatian translation*
Jadranka BOLJUNČIĆ, Sanjin MIHELIĆ

Prijevod na njemački/*German translation*
Marina ŽANIĆ

Lektura/*Language editor*
Ivana MAJER (hrvatski jezik/Croatian)
Sanjin MIHELIĆ, Emmet MARRON (engleski jezik/English)
Marina ŽANIĆ, Katharina HART (njemački jezik/German)

Korektura/*Proofreads*
Marko DIZDAR
Katarina BOTIĆ

Grafičko oblikovanje/*Graphic design*
Roko BOLANČA

Računalni slog/*Layout*
Hrvoje JAMBREK

Tisak/*Printed by*
Tiskara Zelina d.d., Sv. I. Zelina

Naklada/*Issued*
400 primjeraka/400 copies

Sadržaj

Contents

Izvorni znanstveni radovi

Original scientific papers

- | | | |
|-----|--|--|
| 5 | STAŠO FORENBAHER
ZLATKO PERHOČ
Izrađevine od lomljenog kamena iz Nakovane (Pelješac): kontinuitet i promjene od ranog neolitika do kraja prapovijesti | STAŠO FORENBAHER
ZLATKO PERHOČ
<i>Lithic Artifacts from Nakovana (Pelješac): Continuity and Change from Early Neolithic until the End of Prehistory</i> |
| 75 | MARTA RAKVIN
Naselje na gradini Marić kod Mikleuške tijekom kasnoga brončanog i starijeg željeznog doba | MARTA RAKVIN
<i>The Marić Hillfort Settlement near Mikleuška during the Late Bronze and the Early Iron Age</i> |
| 111 | MORANA ČAUŠEVIĆ-BULLY
IVAN VALENT
Municipium Flavium Fulfinum
Dijakronijska studija gradske strukture s posebnim osvrtom na forumski prostor | MORANA ČAUŠEVIĆ-BULLY
IVAN VALENT
<i>Municipium Flavium Fulfinum
Diachronic study of the city structure with a special attention to the forum</i> |
| 147 | ANA KONESTRA
Keramika s Foruma Municipia Flavia Fulfinuma (otok Krk, Hrvatska) – istraživanja od 2007. do 2013. godine | ANA KONESTRA
<i>Pottery from the Forum of Municipium Flavium Fulfinum (Krk Island, Croatia) – research between 2007 and 2013</i> |
| 215 | LJUBICA PERINIĆ
Različite razine sinkretizma na tri Silvanova spomenika | LJUBICA PERINIĆ
<i>Different levels of syncretism on three Silvanus' monuments</i> |
| 229 | JADRANKA BOLJUNČIĆ
JOSIP HAT
Macroscopic and CT Diagnostic Approach in Interpreting a Non-traumatic Calvarial Lesion in a Medieval Man from Northern Croatia | JADRANKA BOLJUNČIĆ
JOSIP HAT
<i>Makroskopski i CT dijagnostički pristup u tumačenju netraumatske lezije na kaloti srednjovjekovnog muškarca iz sjeverne Hrvatske</i> |

Prethodno priopćenje

- 243 MLADEN TOMORAD
JOACHIM SLIWA
Tri staroegipatska skarabeja iz Arheološke zbirke
franjevačkog samostana u Košljunu, Hrvatska
- 251 VESNA LALOŠEVIĆ
Integracija pogana u ranokršćanskim legendama
- 261 ANITA RAPAN PAPEŠA
ÁRPÁD KENÉZ
ÁKOS PETŐ
Arheobotanička analiza uzoraka iz
kasnoavarodobnih grobova iz Nuštra (istočna
Hrvatska)

Recenzije

- 289 SUZANA ČULE
Rimske keramičarske i staklarske radionice.
Proizvodnja i trgovina na jadranskom
prostoru: zbornik II. međunarodnog arheološkog
kolokvija, Crikvenica, 28. –
29. listopada 2011.
- 293 UPUTE AUTORIMA

Preliminary communication

- MLADEN TOMORAD
JOACHIM SLIWA
*Three Ancient Egyptian scarabs from the
Archaeological Collection of the Franciscan
Monastery on Košljun, Croatia*
- VESNA LALOŠEVIĆ
Conversion von Heiden in frühchristliche Legenden
- ANITA RAPAN PAPEŠA
ÁRPÁD KENÉZ
ÁKOS PETŐ
*The Archaeobotanical Assessment of Grave
Samples from the Avar Age Cemetery of
Nuštar (Eastern Croatia)*

Book reviews

- SUZANA ČULE
*Roman Ceramic and Glass Manufactures.
Production and Trade in the Adriatic Region:
Proceedings of the 2nd International
Archaeological Colloquium, Crikvenica, 28 – 29th
October 2011*
- GUIDELINES FOR CONTRIBUTORS

Keramika s Foruma Municipia Flavia Fulfinuma (otok Krk, Hrvatska) – istraživanja od 2007. do 2013. godine*

Pottery from the Forum of Municipium Flavium Fulfinum (Krk Island, Croatia) – research between 2007 and 2013*

Izvorni znanstveni rad
Antička arheologija

Original scientific paper
Roman archaeology

ANA KONESTRA
Institut za arheologiju
Ulica Ljudevita Gaja 32
HR-10 000 Zagreb
ana.konestra@gmail.com

UDK/UDC 903.02(398 Liburnija)“652”

Primljeno/Received: 10. 02. 2015
Prihvaćeno/Accepted: 29. 06. 2015

U radu je obrađena keramička građa sa sustavnih istraživanja lokaliteta foruma Municipia Flavia Fulfinuma (2007.–2013.) smještenog nedaleko od Omišlja na otoku Krku. Materijal koji je podijeljen na amfore, stolno, kućansko i kuhinjsko posuđe, uljanice te keramičke predmete i građevinsku keramiku, kronološki pripada ranoj i kasnoj antici te novom vijeku. Osim tipološko-kronološke obrade nalaza, u čemu su pomogle analogije s okolnim područjima Kvarnera, Dalmacije, Istre te Italije i Slovenije, donosi se i osvrt na njihovu rasprostranjenost na području sjeverne Liburnije ili širega istočnojadranskog prostora. Također, na osnovi obrađenih nalaza pokušalo se interpretirati trgovačka kretanja i navike stanovnika Fulfinuma kroz različita povijesna razdoblja kojima materijal pripada. Tako su uočene određene razlike u zastupljenosti pojedinih klasa što je interpretirano u odnosu na funkciju prostora foruma, odnosno u širem kontekstu trgovačkog prometa na Jadranu: fino stolno posuđe i importi s italskog područja zastupljeni su kroz ranoantičko razdoblje, kao i proizvodi lokalne keramičarske radionice u Crikvenici, dok kasnija razdoblja donose dominaciju afričkih proizvoda, uz rijetke istočne importe. Od kraja 4. stoljeća, s pojavom grube kuhinjske keramike crno-sive strukture, javlja se mogućnost povratka na lokalno/regionalno tržište, iako ishodište ove keramičke vrste nije u potpunosti razjašnjeno.

Ključne riječi: Municipium Flavium Fulfinum, antička keramika, kasnoantička keramika, forum, sjeverna Liburnija

The paper presents the analysis of the pottery assemblage from the systematic excavations at the forum of Municipium Flavium Fulfinum (2007–2013), situated near Omišalj on the Krk Island. The assemblage has been divided into amphorae, tableware, domestic ware and cooking ware, oil lamps, various ceramic objects and construction ceramics, and in terms of chronology belongs to the early and late antiquity and the modern period. In addition to a typo-chronological analysis of the assemblage, which was facilitated by analogies with the neighbouring regions of the Kvarner Gulf, Dalmatia, Istria, as well as Italy and Slovenia, the paper offers a review of their distribution in northern Liburnia and the wider Eastern Adriatic region. Also, based on the analysed finds we attempted to interpret the commercial movements and habits of the residents of Fulfinum through different historical periods to which the assemblage belongs. We have, for instance, perceived certain differences in the frequency of individual categories, which we interpreted with regard to the function of the forum area, as well as in the wider context of the commercial traffic in the Adriatic: fine tableware and imports from the Italian territory are present throughout early antiquity, same as the products of a local ceramic workshop in Crikvenica, whereas African products predominate in the later periods, in addition to the rare imports from the East. From the end of the 4th cent., with the appearance of coarse cooking ware of black-grey fabric there arises also a possibility of regaining the local/regional market, although the place of origin of this ceramic type has not been entirely clarified.

Key words: Municipium Flavium Fulfinum, antique pottery, late antique pottery, forum, northern Liburnia

* Ovaj se rad smješta unutar aktivnosti projekta RED. Roman Economy in Dalmatia: production, distribution and demand in the light of pottery workshops Hrvatske zaklade za znanost (IP-11-2013-3973).

* This paper has been written as part of the activity on the RED Project. Roman Economy in Dalmatia: production, distribution and demand in the light of pottery workshops, funded by the Croatian Science Foundation (IP-11-2013-3973).

UVODNE I METODOLOŠKE PRETPOSTAVKE

Keramički nalazi koje se obrađuje u ovom prilogu potječu s lokaliteta Fulfinum – Forum (otok Krk, Hrvatska) i obuhvaćaju pet terenskih kampanja (2007., 2008., 2010., 2011., 2013.)¹ (Čaušević-Bully, Valent 2015: 121). Lokalitet je smješten unutar uvale Sepen (jugoistočno od Omišlja, pozicije pretpovijesne gradine), na području obilježenoj toponimom Okladi, gdje je ubiciran antički municipij *Flavium Fulfinum*, s kasnijom ranokršćanskom bazilikom na poziciji Mirine i okolnom kasnoantičkom nekropolom, te istočno od pozicije ranoantičke nekropole Kurilovo locirane na poluotoku Ert. Sam se forum smješta unutar istočnog dijela pretpostavljenoga gradskog areala koji se prema dosadašnjim istraživanjima zasigurno prostirao uz sjevernu obalu uvale, dok mu je prostiranje prema sjeveru još uvijek tek pretpostavljeno (više o ovoj problematici u Čaušević-Bully, Valent 2015: 121-129). Osim urbanih struktura koje obuhvaćaju, između ostalog, forum, *horreum*, jednu insulu te urbani rezidencijalni kompleks – vilu, unutar uvale identificiran je i lučni kompleks s molom i lukobranom, te kasnijim fortifikacijskim strukturama (Faber 1986/87; Čaušević-Bully, Valent 2015: 121-129).

Keramički materijal potječe s područja forumske bazilike (Sektor I.2), te s prostora koji se nalazi jugozapadno, odnosno između toga kompleksa i hrama (Sektor I.3). U ranijoj je fazi taj prostor imao funkciju trga, dok je kasnijom interpolacijom manjih struktura realiziranih drvenom građom prenamijenjen u prostor s vjerojatno privatnom funkcijom, što je uočeno i unutar sektora I.2 (Čaušević-Bully, Valent 2015: 129-135, 137-139). S obzirom na višefaznost samog lokaliteta i keramički materijal ima široki kronološki raspon koji obuhvaća razdoblje od 1. do 7. stoljeća, iako je prisutan i recentniji materijal (novovjekovlje). Rijetki su slojevi s kronološki ograničenim nalazima, i uglavnom je ustanovljena visoka koncentracija rezidualnog materijala, što upućuje na intenzivno korištenje prostora uz brojne preinake, o čemu svjedoči i sama stratigrafska situacija na lokalitetu (Čaušević-Bully, Valent 2015: 126-139). Gotovo da nema sloja koji bi sadržavao isključivo nalaze vezane uz jednu od građevinskih faza, a najbrojniji su nalazi iz humusnih slojeva i slojeva nastalih tijekom ranijih istraživanja 1970-ih godina (vidjeti povijest istraživanja u Čaušević-Bully, Valent 2015: 118-121). Ipak, nekoliko je stratigrafskih slojeva moguće interpretirati kao cjeline, o čemu će biti riječi u zaključku. Osim kronološke obrade koja zbog navedenih problema nije uvijek dala zadovoljavajuće rezultate, pokušali smo definirati "procijenjeni broj posuda", što je podrazumijevalo izoliranje dijagnostičkih dijelova posuda (ponajprije rubova, no u nekim su situacijama uzete u obzir i ručke i dna) i dobivanje minimalnoga okvirnog broja posuda, čime se željelo prikazati realnu količinu pojedinih vrsta i tipova. No, zbog velikog broja ulomaka stijenki sav je materijal kvantificiran i prema broju ulomaka pojedine vrste. Kako je gotovo svaki dijagnostički ulomak pokazao zasebne karakteristike, odnosno predstavlja zasebni tip, što znači da se svaki rekon-

¹ Koristim priliku zahvaliti dr. sc. M. Čaušević-Bully, voditeljici istraživanja na lokalitetu *Fulfinum* – Forum, na ustupanju materijala i svesrdnoj pomoći pri njegovoj interpretaciji.

INTRODUCTORY AND METHODOLOGICAL REMARKS

Ceramic finds analysed in this paper come from five seasons of field excavations (2007, 2008, 2010, 2011, 2013)¹ at the Forum of Fulfinum on the Krk Island, Croatia (Čaušević-Bully, Valent 2015: 121). The site is located within the Sepen cove (south-east of the town of Omišalj, which is situated on a prehistoric hillfort), on a land marked by the toponym Okladi. This is the position of the ancient municipium *Flavium Fulfinum*, with a later addition of an early Christian basilica at the site of Mirine and the surrounding late antique necropolis, lying to the east of the early antique necropolis of Kurilovo on the Ert peninsula. The forum itself is situated within the eastern part of the presumed urban area, which based on the research carried out so far had apparently extended along the northern coast of the cove, while its layout towards north is still only assumed (this issue is more extensively covered in Čaušević-Bully, Valent 2015 : 121-129). In addition to urban structures that include, among others, the forum, a *horreum*, an insula and an urban residential complex – a villa, within the cove the research also identified a port complex with a pier and breakwater, as well as later fortification structures (Faber 1986/87; Čaušević-Bully, Valent 2015 : 121-129).

The ceramic assemblage was found in the area of the forum basilica (Sector I.2), and in the area to the south-west, that is, between that complex and the temple (Sector I.3). In the preceding phase this space had the function of a public square, but this changed with a subsequent interpolation of several small timber structures, at which time this space probably acquired a private function, which was also observed within sector I.2 (Čaušević-Bully, Valent 2015: 129-135, 137-139). Analogous to the multi-phase nature of the site, the ceramic assemblage covers a wide chronological span between the 1st and 7th cent., in addition to a more recent material (Modern period). There are only a few layers with chronologically discrete finds, and in most cases the layers exhibit a high concentration of residual material, pointing to an intensive use of space with numerous modifications, as borne out by the general stratigraphy of the site (Čaušević-Bully, Valent 2015: 126-139). There is hardly a layer that contains exclusively finds pertaining to a single construction phase. The most abundant finds come from topsoil and layers formed by previous excavations in the 1970s (see the history of research in Čaušević-Bully, Valent 2015: 118-121). Nevertheless, several stratigraphic layers may be interpreted as contextual units, of which more will be said in the conclusion. In addition to a chronological analysis, which has not always produced satisfactory results due to the described problems, we tried also to define the "estimated number of vessels", which entailed a quantification of diagnostic vessel parts (primarily rims, but in certain situations we also included handles and bases) and calculating the approximate minimum number of vessels, in order to present a realistic number of distinct categories and types. However, due to the large number of wall shards, the assemblage was quantified also based on the number of shards of each type. Since almost every diagnostic shard exhibited distinct features, that is, represents a distinct type, with a corollary that each reconstructed form corresponds to one

¹ I use this opportunity to express my gratitude to Dr M. Čaušević-Bully, the manager of the excavations at *Fulfinum* – Forum, for the permission to analyse the assemblage and for her whole-hearted support in its interpretation.

struirani oblik odnosi na jednu posudu, pri procjeni broja posuda nisu se koristili statistički alati, a zbog istog razloga izrada tipologije posuda (koja bi podrazumijevala određivanje tipova koji se ponavljaju s više primjeraka) nije se pokazala korisnom. Zbog toga smo tako dobivene oblike svrstali u uobičajene keramičke klase, odnosno:

- amfore;
- kućansku keramiku (vrčevi, lonci, poklopci korišteni za skladištenje namirnica ili posluživanje);
- kuhinjsku keramiku (lonci, tave i poklopci korišteni za termičku obradu namirnica);
- fino stolno posuđe (tanjuri i zdjele korišteni za konzumaciju hrane i pića);
- uljanice;
- novovjekovnu keramiku;
- utege za mreže;
- građevinsku keramiku.

Zbog istoga se razloga unutar materijala javlja velik broj različitih keramičkih struktura koje je tek ponekad bilo moguće grupirati, tako da se većina opisa struktura odnosi na jedan tip/posudu. One grupe koje se odnose na više tipova, donosimo u tab. 26. Sve su strukture obrađene makroskopski, a one grube i mikroskopski.²

Rijetki numizmatički nalazi potvrđuju generalne datacije 1. i 2. stoljeća, no ne pomažu u preciznijoj dataciji samih slojeva, a što se keramičkih nalaza tiče daju nam tek kronološki *terminus post quem* za pojedine slojeve. Zbog nedostatka drugih kronoloških pokazatelja, izuzevši fino stolno posuđe dobro definiranih kronologija (različite sigilate i keramika tankih stijenki) i amfore, koje je također moguće nešto preciznije datirati, većina keramičkog materijala datirana je prema analogijama s materijalom s različitih lokaliteta. Problem ove vrste datiranja javlja se na područjima gdje ne postoje brojne objave ili razrađene regionalne tipologije koje bi mogle poslužiti kao najbliži komparativni materijal, pa je tada analogije potrebno potražiti na širem zemljopisnom prostoru, što u pravilu proširuje i kronologiju. Upravo je to slučaj s područjem Kvarnera (sjeverne Liburnije) gdje su objave keramičkog materijala izrazito oskudne. Zahvaljujući objavama importiranoga finog stolnog posuđa (Makjanić 1983; 1987; 1988), te jedinoj opsežnoj objavi jednoga kasnoantičkog lokaliteta, Tarsatičkog principija (Radić Štivić, Bekić 2009), omogućena je komparativna statistička analiza na pojedinim vrstama, dok su ostale objave materijala s obližnjih lokaliteta korištene za analogije pojedinih tipova. Objave materijala iz antičke keramičarske radionice u Crikvenici pomogle su kod identificiranja tipova lokalno proizvedene keramike ranocarskog razdoblja³ (Lipovac Vr-

pot, in the estimation of the number of pots we did not employ statistical tools. Furthermore, this is also the reason why the attempt to build a pottery typology (which would entail determination of recurrent types consisting of several specimens) failed to prove of use. Due to this we divided the forms obtained in this way into usual ceramic categories, specifically:

- amphorae;
- domestic ware (jugs, jars, lids used for storing or serving food);
- cooking ware (jars, pans and lids used for thermic processing of foodstuffs);
- fine tableware (plates and bowls used for consumption of food and drink);
- oil lamps;
- modern-period pottery;
- fishing-net weights;
- construction ceramics.

Due to this reason the assemblage contains a large number of different fabrics, which could only occasionally be attributed to groups, so that most descriptions of fabrics refer to a single type/pot. Groups referring to several types are described in Table 26. All the fabrics were analysed macroscopically, while the coarse ones were examined also with a microscope.²

The rare numismatic finds corroborate the general dating to the 1st and 2nd cent., however, they are not of help in the precise dating of the layers themselves. When it comes to ceramic finds, all they provide is a chronological *terminus post quem* for certain strata. Due to the lack of other chronological indicators, with the exception of fine tableware with well-defined chronologies (various sigillatas and thin-walled pottery) and amphorae, which can also be defined with a greater degree of accuracy, the bulk of the ceramic assemblage was dated based on analogies with material from various sites. The problem with such a dating appears in areas lacking numerous publications or elaborate regional typologies that might serve as the nearest comparative material, in which one necessarily looks for analogies in a wider geographic area, which as a rule expands also the chronology. This is precisely the case with the Kvarner Gulf area (northern Liburnia), which is extremely lacking in publications of ceramic assemblages. Owing to the publications of imported fine tableware (Makjanić 1983; 1987; 1988), and the only extensive publication of a late antique site, the Principia of Tarsatica (Radić Štivić, Bekić 2009), we were able to carry out a comparative statistical analysis of specific types, while the other publications of assemblages from nearby sites were used as analogies for individual types. The publications of the material from the antique ceramic workshop in Crikvenica were used for identifying the types of locally-produced pottery from the early Imperial period³ (Lipovac Vrkljan 2009; 2011; Ožanić Roguljić 2012; 2012a).

2 Za mikroskopsku analizu korišteni su stereo mikroskop BTC STM 5 T 20x/40x i digitalni mikroskop Dino – lite AM 413T.

3 Datacija najvećeg zamaha proizvodnje unutar crikveničke keramičarske radionice zasigurno obuhvaća 1. st. pos. Kr. (Lipovac Vrkljan 2011: 11), međutim s obzirom na to da su istraživanja na ovom lokalitetu još uvijek u tijeku, početak i kraj proizvodnje za sada nije moguće definirati sa sigurnošću, iako je korištenje ovoga prostora ¹⁴C analizama smješteno između druge polovine 1. st. pr. Kr. i 2. st. pos. Kr., no prema novijim nalazima možemo produžiti to razdoblje do 4. stoljeća (Lipovac Vrkljan, Šiljeg 2008: 91; Šiljeg et al. 2013: 126).

2 For the microscopical analysis we used a stereo microscope BTC STM 5 T 20x/40x and digital microscope Dino – lite AM 413T.

3 The heyday of production in the Crikvenica ceramic workshop undoubtedly falls into the 1st cent. AD (Lipovac Vrkljan 2011: 11). However, considering that the excavation at this site is still in progress, the beginning and end of the production cannot be determined with certainty at the time being, although radiocarbon results date the use of this space between the second half of the 1st cent. BC and the 2nd cent. AD. However, recent finds suggest that we may extend this period until the 4th cent. (Lipovac Vrkljan, Šiljeg 2008: 91; Šiljeg et al. 2013: 126).

kljan 2009; 2011; Ožanić Roguljić 2012; 2012a). Zbog navedenih poteškoća kod datacija većine materijala odlučili smo se za najmanju kronološku podjelu od 50 godina, odnosno na prvu i drugu polovinu pojedinih stoljeća.

Zaključno valja istaknuti kako su pojedine vrste materijala omogućile detaljniju analizu, što zbog veće količine dijagnostičkih ulomaka (npr. amfore), što zbog posebnosti oblika i općenito boljoj istraženosti (npr. tanjuri *orlo bifido*), dok su druge omogućile tek kvantitativno-kronološku raspravu.

Analiza struktura, premaza i ukrasa

Analiza struktura i premaza, u slučaju njegova postojanja, provedena je na svim ulomcima. Međutim, poseban popis struktura vođen je isključivo za kuhinjsku (grubu) keramiku, dok su za fino stolno posuđe i amfore korišteni ustaljeni opisi struktura:

- italska *terra sigillata*: strukture A, B i C (Schindler, Scheffenegger 1977; Ettlinger et al. 1999);
- keramika tankih stijenki: fabrikati prema Schindler Kaudelka 1975;
- afrička sigilata i amfore: strukture prema Bonifay 2004;
- istočna sigilata: proizvodnje prema Hayes 1985;
- galska sigilata: fabrikati prema Delage 2010.

Premazi ovih vrsta također su grupirani prema navedenim tipologijama.

Strukture amfora posebno su registrirane zbog velikog broja nedijagnostičkih ulomaka, no, kada je to bilo moguće, povezane su uz uobičajene tipologije. Opis struktura ulomaka ostalih keramičkih vrsta donosi se unutar tablica kataloga (osim uljanica, za koje su primijećene tri različite strukture, opisane u pripadnom poglavlju).

Strukture grube kuhinjske keramike su, nakon početne registracije, grupirane prema boji, te vrsti i količini primjesa (tab. 26). Naime, primijećeno je da se gotovo svaki ulomak razlikuje od ostalih; međutim, mikroskopskom analizom ustanovljene su određene sličnosti koje su potom korištene za formiranje navedenih grupa. Nepostojanje referentnih tipologija za kvarnersko područje onemogućilo je direktno povezivanje na već postojeću tipologiju; međutim, kada je to bilo moguće, donose se i analogije struktura.

Tretman površine za ove dvije keramičke vrste – premaz ili zaglađivanje – opisan je uz svaku kategoriju struktura zasebno.

Ukrasi su registrirani zasebno kao dijagnostički element (tab. 27, T. 11).

Amfore

Zbog izrazite fragmentarnosti svih keramičkih nalaza, pa tako i amfora, preciznija definicija tipova bila je moguća samo za ulomke rubova. Ostali su nalazi, tj. dna, ručke i stijenke, definirani uglavnom samo prema keramičkoj strukturi što je omogućilo grupiranje prema pretpostavljenom području proizvodnje: Italija ili lokalna proizvodnja (jadranska proizvodnja),⁴ Hispanija, sjeverna Afrika, istočni Mediteran, te amfore nesigurne identifikacije.

4 U slučaju lokalne proizvodnje ulomci su identificirani prema tipologiji proizvoda crikveničke radionice, odnosno prema njihovoj strukturi (Lipovac Vrkljan 2011; Ožanić Roguljić 2012: 118). Međutim, u ovoj fazi istraživanja nisu provedena arheometrijska istraživanja koja bi sa sigurnošću potvrdila lokalnu provenijenciju.

Due to these obstacles, in the dating of most finds we decided to put forward the least chronological division of 50 years, that is, we dated the finds to the first or latter halves of the cent..

In conclusion, it may be stressed that certain types of material lend themselves well to a detailed analysis, due to a large quantity of diagnostic shards (e.g. amphorae), due to a distinct shape or, generally, owing to the fact that they were more thoroughly researched (e.g. *orlo bifido* plates), while others could only be discussed in quantitative-chronological terms.

Analysis of fabrics, slips and decorations

The analysis of fabrics and slips, when the latter was present, was carried out for all the shards. However, a specific list of fabrics was maintained only for cooking- (coarse) ware, while the usual fabric descriptions were used for fine tableware and amphorae:

- Italic *terra sigillata*: fabrics A, B and C (Schindler, Scheffenegger 1977; Ettlinger et al. 1999);
- thin-walled pottery: fabrics After Schindler Kaudelka 1975;
- African sigillata and amphorae: fabrics after Bonifay 2004;
- Eastern sigillata: productions after Hayes 1985;
- Gaulish sigillata: fabrics after Delage 2010.

Slips of these categories were also grouped based on the mentioned typologies.

We documented the fabrics for amphorae separately due to a large number of undiagnostic shards, although they were attributed to the usual typologies whenever possible. The description of the fabrics of shards of the remaining pottery types is presented in the tables of the catalogue (except for oil lamps, which feature three different fabrics, described in the corresponding chapter).

Fabrics of coarse cooking ware, following the initial registration, were grouped based on the colour, type and quantity of inclusions (Tab. 26). It was observed that almost every shard is different from the rest; however, the microscopical analysis revealed certain similarities, which were then used for the creation of the mentioned groups. The absence of reference typologies for the Kvarner Gulf thwarted any direct connections with already existing typologies; however, whenever it was possible, we provided analogies for the fabrics.

Surface treatment for these two pottery types—slip or smoothing—was described for each fabric category separately.

Decorations were registered separately as a diagnostic element (Tab. 27, Pl. 11).

Amphorae

Due to the pronounced fragmentation of all ceramic finds, including amphorae, it was possible to offer a more precise definition of types only for rim shards. The remaining finds, i.e. bases, handles and walls, were defined mostly only based on the ceramic fabric, which enabled grouping by the presumed origin of production: Italy or local production (Adriatic production),⁴ Hispania, North Africa, Eastern Mediterranean, and indeterminate amphorae.

4 Locally-produced shards were identified according to the typology of the products of the Crikvenica workshop, that is, their fabric (Lipovac Vrkljan 2011; Ožanić Roguljić 2012: 118). However, in this phase of research we have not carried out archaeometric studies that would ascertain the local origin.

Prema analizi dijagnostičkih ulomaka ustanovljen je najmanje 21 zaseban primjerak amfore, a većina identificiranih tipova pripada afričkim amforama čiji je kronološki raspon od 3. do 7. stoljeća, dok se manji broj nalaza može identificirati s proizvodima drugih navedenih područja (graf. 1).

Italске i jadranske amfore (T. 1, tab. 1)

Amforama italčkog podrijetla, koje su i najraniji identificirani tipovi, s većom sigurnošću moguće je pripisati tek dna N-39-4 (T. 1: 1) i N-39-5 (T. 1: 2) koja bi se mogla tipološki povezati uz "Forlimpopoli" amfore, vjerojatno uz tip C prema Aldiniju (Aldini 1978: 238). Ovoj tipologiji, ali tipu D, mogli bismo pripisati i ručku N-131-24 (T. 1: 3) (Aldini 1999: 30, Fig. 13). Amfore tipa Forlimpopoli javljaju se u 1. stoljeću, no tipovi C i D datiraju u 2. stoljeće, dok se D vjerojatno prote-

The analysis of diagnostic shards established a minimum of 21 separate specimens of amphorae. Most identified types belong to African amphorae, spanning the period between the 3rd and 7th cent., while a few finds may be identified with products from the other mentioned areas (graph 1).

Italic and Adriatic amphorae (Pl. 1, Tab. 1)

To amphorae of Italic origin, which are also the earliest identified types, we may attribute with a degree of certainty only bases N-39-4 (Pl. 1: 1) and N-39-5 (Pl. 1: 2), which might be typologically associated with the "Forlimpopoli" amphorae, probably type C after Aldini (Aldini 1978: 238). To the same typology, but type D, we might attribute also handle N-131-24 (Pl. 1: 3) (Aldini 1999: 30, Fig. 13). Forlimpopoli-type amphorae appear also in the 1st cent., but types C

Crtež	Br. n.	SJ	Oblik ulomka / Tip	Datacija	Analogije
T. 1: 1	N-39-4	I.3002	Dno / Forlimpopoli C	2. st.	Aldini 1978: 238
T. 1: 2	N-39-5	I.3002	Dno / Forlimpopoli C	2. st.	Aldini 1978: 238
T. 1: 4	N-131-24	I.4000	Vrat s ulomkom ručke / Forlimpopoli D	2.-3. st.	Aldini 1999: 30, Fig. 13
T. 1: 3	N-39-6	I.3002	Dno / Crikvenica Tip 1	1.-2. st.	Lipovac Vrkljan 2011: T. 1-2
Drawing	No. f.	SU	Shard form / Type	Date	Analogy
Pl. 1: 1	N-39-4	I.3002	Base / Forlimpopoli C	2 nd century	Aldini 1978: 238
Pl. 1: 2	N-39-5	I.3002	Base / Forlimpopoli C	2 nd century	Aldini 1978: 238
Pl. 1: 4	N-131-24	I.4000	Neck with a part of handle / Forlimpopoli D	2 nd -3 rd century	Aldini 1999: 30, Fig. 13
Pl. 1: 3	N-39-6	I.3002	Base / Crikvenica Type 1	1 st -2 nd century	Lipovac Vrkljan 2011: T. 1-2

Tab. 1 Italске i jadranske amfore

Tab. 1 *Italic and Adriatic amphorae*

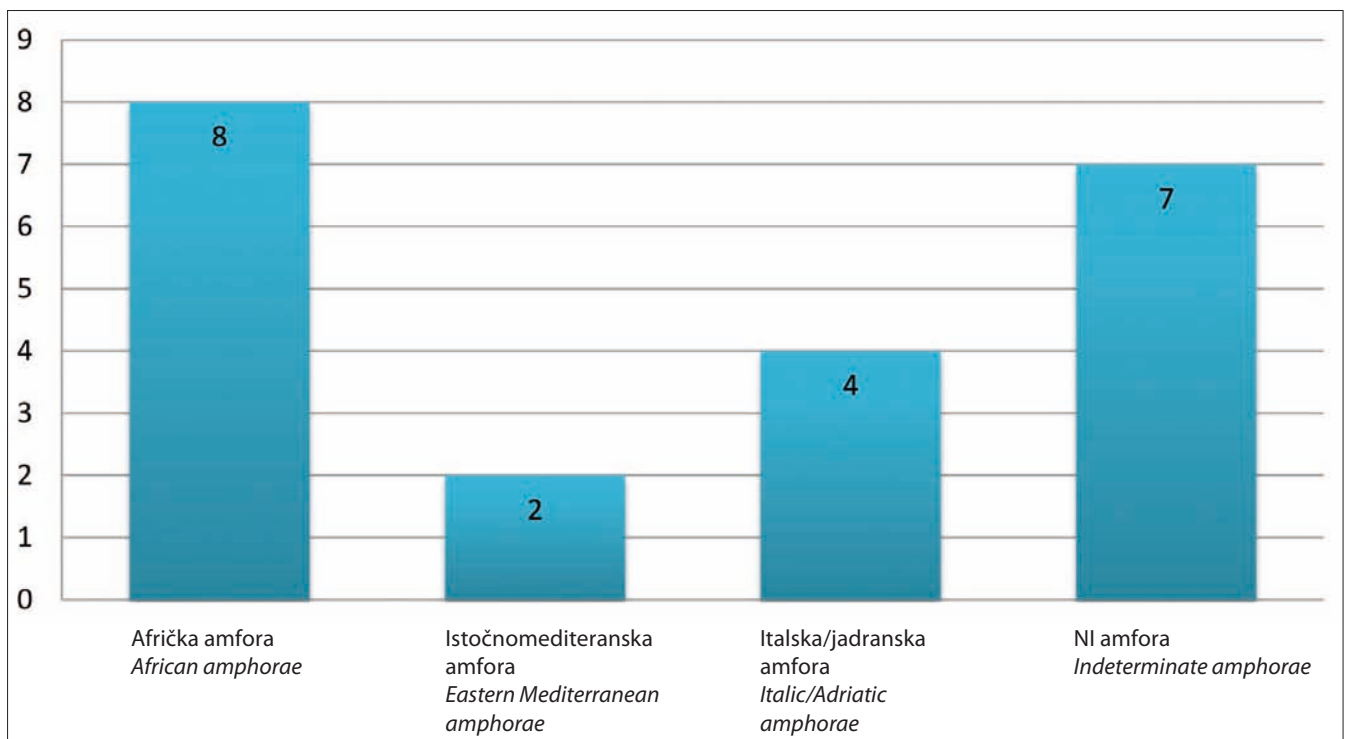

Graf. 1 Amfore: procijenjeni broj posuda prema podrijetlu

Graph 1 Amphorae: estimated number of vessels by origin

že i kroz 3. stoljeće. Ova se tipologija povezuje uz transport vina sa zapadne obale Jadrana, a teret ovih amfora pronađen je kod Ilovika, dok su na Kvarneru brojni i pojedinačni nalazi amfora ovoga tipa (Jurišić 2000: 20–21, Pl. 7, Fig. 10). Forlimpopoli amfore smještaju se u širu kategoriju jadranskih amfora ravnog dna čija je lokalna inačica crikvenička amfora ravnog dna (Lipovac Vrkljan 2011: 9–10), s kojom bismo mogli povezati dno N-39-6 (T. 1: 4), te ga datirati u sličan vremenski raspon od 1. do 2. stoljeća.

Afričke amfore (T. 2, 3, tab. 2)

Među ranije primjerke afričkih amfora smješta se rub amfore N13-A1-1 (T. 2: 1) tipa *Africana Ia* (Keay IIIa, *Africana piccolo*) karakteristična za kraj 2. i početak 3. stoljeća (Bonifay 2004: 107). Nešto kasnije kronološke odrednice ima rub N-131-22 (T. 2: 2) tipa *Africana II con gradino/Keay V* koja se prema literaturi datira u 3. stoljeće (Bonifay 2004: 111–114), a na Kvarneru su nalazi ove amfore prilično brojni: Lopar, Jurjevo, uvala Duboka kraj Selca, Povile, Senjska vrata, nekoliko ih se čuva u osorskom muzeju, a poznat je primjerak iz Omišaljškog zaljeva (Matejčić 1976: 353; Pešić 2013: 1208, Fig. 2). Ovom bismo tipu mogli pripisati i dva ulomka iz Senja (Fadić 1999: 52–53, T. 2/4, 11). U varijanti *Africana IIa* i *IIb* prisutne su u Tarsatičkom principiju (Višnjić 2009: 125–126), te *IIc* u podmorju otoka Krka (Dugonjić 2010: 221–223). Dok se za tip I pretpostavlja prijevoz ulja, za tip *IIb* nemamo indikacija o sadržaju (Bonifay 2004: 107, 111–114, 474).

Ulomak ruba N-5-1 (T. 2: 3) smještamo u varijantu *Spatheion 1a/Keay 26* ili pak u tip *Africana IIIb/Keay 25.2* (Bonifay 2004: 122, 125) koje se međusobno razlikuju u dimenzijama, a samo na osnovi ruba teško je definirati točan tip. Jednom od ovih tipova, vjerojatno *Spatheion 1/Keay 26*, mogli bismo pripisati i šiljasto dno N-16-4 (T. 3: 14), a varijanti *Spatheion 1d* rub N13-A1-6 (T. 2: 4), no zbog doista malog ulomka atribucija je upitna. Datacija obaju tipova obuhvaća 4. i prvu polovinu/sredinu 5. stoljeća (Bonifay 2004: 122, 125). Na Kvarneru brojni su primjeri *spatheiona* s lokaliteta Tarsatičkog principija (Višnjić 2009: 126–127), a ovim tipologijama vjerojatno pripada i nekoliko ulomaka iz Senja (Fadić 1999: 52–53, T. 2/5, 7; Starac, R. 1999: 75–77, T. 10/3). Teško je definirati sadržaj ovih tipova, pa dok se za Keay 25.2 pretpostavljaju vino ili masline, za *spatheion 1a* se uz navedene namirnice pretpostavlja i transport *salsamenta* (Bonifay 2004: 474).

Amforama datiranima u 5. stoljeće pripadaju i rubovi N-1-5 (T. 2: 5) koji je identificiran kao tip Keay 35a i N-23-4 (T. 2: 6) identificiran kao Keay 35b. Njihova je proizvodnja potvrđena u tuniskoj pokrajini Nabeul (radionice Sidi Aoun i Sidi Zahruni), a za 35b pretpostavljena je i u Bizaceni (Bonifay 2004: 135; Ghalia et al. 2005: 496; ADS Roman amphorae Keay 35A)⁵. Prva je varijanta korištena za transport ulja, dok je tipom Keay 35b vjerojatno prevožena *salsamenta* (Bonifay 2004: 135, 474; Ghalia et al. 2005: 497).

Ulomak ruba N-131-23 (T. 2: 7) smještamo u tipologiju Keay 62 amfora kojoj pripada velik broj podtipova, no zbog

and D are dated to the 2nd cent., while type D probably continues also through the 3rd cent.. This typology is connected with the transport of wine from the western coast of the Adriatic Sea. A cargo of these amphorae was found off the Ilovik Island, while the Kvarner Gulf abounds in individual finds of amphorae of this type (Jurišić 2000: 20–21, Pl. 7, Fig. 10). Forlimpopoli amphorae belong to a wider category of Adriatic flat-based amphorae, one of whose local variants is the Crikvenica flat-based amphora (Lipovac Vrkljan 2011: 9–10), with which we might associate base N-39-6 (Pl. 1: 4).

African amphorae (Pl. 2, 3, Tab. 2)

Amphora rim N13-A1-1 (Pl. 2: 1) of type *Africana Ia* (Keay IIIa, *Africana piccolo*) is an early specimen of African amphorae, characteristic for the end of the 2nd cent. and the beginning of the 3rd cent. (Bonifay 2004: 107). Somewhat later chronological features are present on rim N-131-22 (Pl. 2: 2) of type *Africana II con gradino/Keay V*, dated according to the literature to the 3rd cent. (Bonifay 2004: 111–114). Finds of this amphora type are fairly common in the Kvarner Gulf: Lopar, Jurjevo, Duboka cove near Selce, Povile, the Senj Gate; several finds are kept in the Osor Museum and one specimen is known from the Omišalj cove (Matejčić 1976: 353; Pešić 2013: 1208, Fig. 2). To this type we may also attribute two shards from Senj (Fadić 1999: 52–53, T. 2/4, 11). They are present also in the Tarsatica Principia with its *Africana IIa* and *IIb* variants (Višnjić 2009: 125–126), as well as in the underwater zone of the Krk Island with variant *IIc* (Dugonjić 2010: 221–223). While type I was presumably used for the transport of oil, we have no indications for the content of type *IIb* (Bonifay 2004: 107, 111–114, 474).

We place rim shard N-5-1 (Pl. 2: 3) into the *Spatheion 1a/Keay 26* variant, or type *Africana IIIb/Keay 25.2* (Bonifay 2004: 122, 125). The two differ in dimensions, and the exact type is difficult to determine based solely on the rim. We may attribute pointed base N-16-4 (Pl. 3: 14) to one of these types, probably *Spatheion 1/Keay 26*, while rim N13-A1-6 (Pl. 2: 4) might belong to variant *Spatheion 1d*, although the latter attribution is doubtful due to the very small size of the shard. The dating of both types spans the 4th cent. and the first half/middle of the 5th cent. (Bonifay 2004: 122, 125). The Kvarner Gulf yielded a number of *spatheions* at the Principia site in Tarsatica (Višnjić 2009: 126–127), and to these typologies we might also probably attribute several shards from Senj (Fadić 1999: 52–53, T. 2/5, 7; Starac, R. 1999: 75–77, T. 10/3). The contents of these types are difficult to determine; for instance, in the case of Keay 25.2 wine or olives are likely candidates, while for *spatheion 1a* it is presumed that *salsamenta* may have been transported in them alongside these foodstuffs (Bonifay 2004: 474).

To amphorae dated to the 5th cent. we may also add rims N-1-5 (Pl. 2: 5), identified as type Keay 35a, and N-23-4 (Pl. 2: 6), identified as Keay 35b. Their production has been confirmed in the Nabeul province in Tunisia (the workshops of Sidi Aoun and Sidi Zahruni), while the production of type 35b is presumed also in Bizacena (Bonifay 2004: 135; Ghalia et al. 2005: 496; ADS Roman amphorae Keay 35A)⁵. The first variant was used for the transport of oil, while type Keay 35b was probably used for *salsamenta* (Bonifay 2004: 135, 474; Ghalia et al. 2005: 497).

⁵ Ulomak N-1-5 po keramičkoj strukturi odgovara tuniskoj proizvodnji iako mu nedostaje tipičan bijeli premaz na površini, što bismo mogli pripisati lošem stanju očuvanosti.

⁵ Shard N-1-5 is analogous to the Tunisian production by its ceramic fabric, although it lacks the typical white slip on the surface, which might be attributed to its poor state of preservation.

Crtež	Br. n.	SJ	Oblik ulomka / Tip – struktura	Datacija	Analogije
T. 2: 1	N13-A1-1	I.2100; I.2101; I.2103;	Rub / Africana Ia (Keay IIIa, Africana piccolo, Amphore type 21)	Kraj 2. i početak 3. st.	Keay 1984: Fig. 37: 5; Bonifay 2004: Fig. 56
T. 2: 2	N-131-22	I.4000	Rub / Africana II b "con gradino"/ Keay V (Amphore type 23)	3. st.	Keay 1984: Fig. 42: 3; Bonifay 2004: Fig. 59
T. 2: 3	N-5-1	I.3002	Rub / <i>Spatheion</i> 1a/Keay 26/Amphore type 31 ili Africana IIIb/Keay 25.2/ Amphore type 29	4. i prva polovina – sredina 5. st.	Keay 1984: Fig. 90: 10, 79: 7; Bonifay 2004: Fig. 65, 67
T. 2: 4	N13-A1-6	I.2100; I.2101; I.2103;	Rub / <i>Spatheion</i> 1d/ Keay 26/ Amphore type 31	4. i prva polovina – sredina 5. st.	Keay 1984: Fig. 90: 5–6; Bonifay 2004: Fig. 67
T. 2: 5	N-1-5	I.3001	Rub / Keay 35a/Amphore type 40	5. st.	Keay 1984: Fig. 99: 2; Bonifay 2004: Fig. 72a
T. 2: 6	N-23-4	I.3002	Rub / Keay 35b/Amphore type 41	5. st.	Keay 1984: 101: 9; Bonifay 2004: 72a
T. 2: 7	N-131-23	I.4000	Rub / Keay 62/Amphore type 46	Od kraja 5. do početka 7. st.	Keay 1984: 136: 10; Bonifay 2004: Fig. 74
T. 2: 8	N-16-2	I.3002	Rub – vrat / Bonifay 64 – 66	6.–8. st.	Bonifay 2004: Fig. 83
T. 3: 1	N-131-25	I.4000	Ručka / Boja: 2.5R 5/6; Primjese: povremene veće bijele, česte sitne sjajne		
T. 3: 2	N-131-26	I.4000	Ručka / Boja: 2.5YR 5/6; Primjese: česte sitne bijele, povremene sitne crne		
T. 3: 3	N-5-6	I.3002	Ručka / Boja: 5YR 6/6; Primjese: česte sitne crne i crvene; Rupice: povremene		
T. 3: 4	N-1-2	I.3001	Ručka / Boja: 5YR 6/6; Primjese: česte sitne sjajne, povremene srednje sive		
T. 3: 5	N08-A4-4	I.2001	Vrat / Boja: 10R 5/8; Primjese: povremene srednje crvene, rijetke sitne sive i velike sjajne		
T. 3: 6	N07-A1-1	Površinski nalaz uz južne stube	Vrat / Boja: 2.5YR 4/6; Primjese: česte sitne bijele, rijetke sitne sive		Africana Ila grande?
T. 3: 7	N13-A1-7	I.2100; I.2101; I.2103;	Ručka / Boja: 2.5 YR 5/8; Primjese: sitne male bijele; Premaz: bjelkasti		
T. 3: 8	N13-A1-8	I.2100; I.2101; I.2103;	Ručka / Boja: 2.5 YR 6/8; Primjese: velike bijele, bež, sive i crvene		
T. 3: 9	N13-A1-10	I.2100; I.2101; I.2103;	Ručka / Boja: 2.5 YR 4/8; Primjese: sitne sjajne, rijetke sitne bijele		
T. 3: 10	N-5-4	I.3002	Dno / Boja: 2.5YR 4; Primjese: česte sitne žučkaste, povremene srednje i sitne crne; Rupice: povremene, raznih dimenzija; Premaz: sivozeleni (5YR 5/1)		
T. 3: 11	N-23-6	I.3002	Dno / Boja: 2.5Yr 5/8, površinski: 7.5Yr 6/4; Primjese: česte sitne bijele, rijetke velike bijele		Afrička amfora?
T. 3: 12	N-23-7	I.3002	Dno / Boja: 2.5YR 6/8; Primjese: česte sitne i srednje crne, povremene sitne sjajne		Afrička amfora?
T. 3: 13	N-16-3	I.3002	Dno / Boja: 10R 5/8; Primjese: česte sitne sjajne i bijele; rijetke velike crvene; Rupice: česte sitne; Premaz: 10R 3/2		
T. 3: 14	N-16-4	I.3002	Dno / Africana IIIb/Keay 25.2/26	4. – pol. 5. st.?	Keay 1984: Fig. 88 (var. 2); Bonifay 2004: Fig. 65
T. 3: 15	N07-A1-2	Površinski nalaz uz južne stube	Dno / Boja: 2.5YR 4/6, 10R 5/1; Primjese: česte sitne bijele		

Tab. 2 Afričke amfore

Drawing	No. f.	SU	Shard form / Type – fabric	Date	Analogy
Pl. 2: 1	N13-A1-1	I.2100; I.2101; I.2103;	Rim / Africana Ia (Keay IIIa, Africana piccolo, Amphore type 21)	End of 2 nd and beginning of 3 rd century	Keay 1984: Fig. 37: 5; Bonifay 2004: Fig. 56
Pl. 2: 2	N-131-22	I.4000	Rim / Africana II b "con gradino"/ Keay V (Amphore type 23)	3 rd century	Keay 1984: Fig. 42: 3; Bonifay 2004: Fig. 59
Pl. 2: 3	N-5-1	I.3002	Rim / Spatheion 1a/Keay 26/Amphore type 31 or Africana IIIb/Keay 25.2/ Amphore type 29	4 th and first half/mid-5 th century	Keay 1984: Fig. 90: 10, 79: 7; Bonifay 2004: Fig. 65, 67
Pl. 2: 4	N13-A1-6	I.2100; I.2101; I.2103;	Rim / Spatheion 1d/ Keay 26/ Amphore type 31	4 th and first half/mid-5 th century	Keay 1984: Fig. 90: 5–6; Bonifay 2004: Fig. 67
Pl. 2: 5	N-1-5	I.3001	Rim / Keay 35a/Amphore type 40	5 th century	Keay 1984: Fig. 99: 2; Bonifay 2004: Fig. 72a
Pl. 2: 6	N-23-4	I.3002	Rim / Keay 35b/Amphore type 41	5 th century	Keay 1984: 101: 9; Bonifay 2004: 72a
Pl. 2: 7	N-131-23	I.4000	Rim / Keay 62/Amphore type 46	From the end of 5 th to beginning of 7 th century	Keay 1984: 136: 10; Bonifay 2004: Fig. 74
Pl. 2: 8	N-16-2	I.3002	Rim – neck/ Bonifay 64 – 66	6 th -8 th century	Bonifay 2004: Fig. 83
Pl. 3: 1	N-131-25	I.4000	Handle / Colour: 2.5R 5/6; Inclusions: occasional larger white, frequent small glossy		
Pl. 3: 2	N-131-26	I.4000	Handle / Colour: 2.5YR 5/6; Inclusions: frequent small white, occasional small black		
Pl. 3: 3	N-5-6	I.3002	Handle / Colour: 5YR 6/6; Inclusions: frequent small black and red; Holes: occasional		
Pl. 3: 4	N-1-2	I.3001	Handle / Colour: 5YR 6/6; Inclusions: frequent small glossy, occasional medium grey		
Pl. 3: 5	N08-A4-4	I.2001	Neck / Colour: 10R 5/8; Inclusions: occasional medium red, rare small grey and large glossy		
Pl. 3: 6	N07-A1-1	Surface find next to southern staircase	Neck / Colour: 2.5YR 4/6; Inclusions: frequent small white, rare small grey		Africana Ila grande?
Pl. 3: 7	N13-A1-7	I.2100; I.2101; I.2103;	Handle / Colour: 2.5 YR 5/8; Inclusions: small white; Slip: whitish		
Pl. 3: 8	N13-A1-8	I.2100; I.2101; I.2103;	Handle / Colour: 2.5 YR 6/8; Inclusions: large white, beige, grey and red		
Pl. 3: 9	N13-A1-10	I.2100; I.2101; I.2103;	Handle / Colour: 2.5 YR 4/8; Inclusions: small glossy, rare small white		
Pl. 3: 10	N-5-4	I.3002	Base / Colour: 2.5YR 4; Inclusions: frequent small yellowish, occasional medium and small black; Holes: occasional, various sizes; Slip: grey-green (5YR 5/1)		
Pl. 3: 11	N-23-6	I.3002	Base / Colour: 2.5Yr 5/8, surface: 7.5Yr 6/4; Inclusions: frequent small white, rare large white		African amphora?
Pl. 3: 12	N-23-7	I.3002	Base / Colour: 2.5YR 6/8; Inclusions: frequent small and medium black, occasional small glossy		African amphora?
Pl. 3: 13	N-16-3	I.3002	Base / Colour: 10R 5/8; Inclusions: frequent small glossy and white; rare large red; Holes: frequent small; Slip: 10R 3/2		
Pl. 3: 14	N-16-4	I.3002	Base / Africana IIIb/Keay 25.2/26	4 th – mid-5 th century?	Keay 1984: Fig. 88 (var. 2); Bonifay 2004: Fig. 65
Pl. 3: 15	N07-A1-2	Surface find next to southern staircase	Base / Colour: 2.5YR 4/6, 10R 5/1; Inclusions: frequent small white		

Tab. 2 African amphorae

malih dimenzija ulomka nismo u mogućnosti definirati ga preciznije. Stoga je i predložena datacija nešto šira te obuhvaća razdoblje od kraja 5. do početka 7. stoljeća (Bonifay 2004: 137–160). Nisu poznate namirnice koje su se prevozile ovim amforama, no za jednu od varijanti pretpostavljaju se vino i *salsamenta* (Bonifay 2004: 474).

Rub N-16-2 (T. 2: 8) tip je koji bismo smjestili unutar grupe Bonifay 64 – 66 (Bonifay 2004: 151–153). Riječ je o tzv. globularnim amforama (*anfore globulari*, *anfore tipo Castrum Perti*, *amphore globulaire*) koje datiraju od 6. do 8. stoljeća te se smatraju bizantskim razvojem pojedinih LRA i afričkih tipova, a proizvodnja se smješta kako na istočnom Mediteranu tako i u sjevernoj Africi i Italiji (talijanska je proizvodnja identificirana posebice na jugu poluotoka, a jedan od najraširenijih tipova je onaj *Crypta Balbi*). Točniji tip našeg primjerka teže je odrediv, no vjerojatno pripada afričkoj proizvodnji, pa ga stoga ne bismo smjestili uz tipove LRA 2 ili 13 nego bismo ga usporedili s tipovima vinskih amfora iz Kartage (Bonifay 2004: 152–153, type 64/3, type 66/1, 475). Ipak, nekoliko ulomaka narebrenih stijenki “afričke” strukture koji su zamijećeni unutar materijala mogli bismo također povezati uz tip globularnih amfora. Osim s navedenim ulomcima, morfološka, ali i strukturna se sličnost očituje i s ulomkom neidentificirane amfore koja potječe s otoka S. Andrea (Marano (UD) (Villa 1998: 227–229, Fig. 2: 10), te s ulomkom *Ostia IV*, 284 na kojem je također prisutan žućkasti premaz (Manacorda 1977: 127, Fig. 284). Valja napomenuti da su rubovi ovih primjeraka ipak nešto drukčiji, iako se ručke vežu na vrat na gotovo identičan način. Različiti tipovi globularnih amfora prisutni su na gornjem Jadranu i sjevernoj Italiji (Gelichi et al. 2006; Gelichi, Negrelli 2008: 314–323; Cirelli 2009).

Afričkim amforama, na osnovi keramičke strukture, pripisali bismo još i ručke, vrat te dna koje donosimo u tab. 2 i T. 3.

Istočnomediteranske amfore (T. 4, tab. 3)

Eventualni primjerci istočnomediteranskih amfora identificirani su isključivo prema strukturama kojima pripada nekoliko ulomaka ručki: N-16-6 (T. 4: 1), N-16-7 (T. 4: 2) i N-1-1 (T. 4: 3). Svijetla struktura s mnoštvom primjesa kako na površini tako i u presjeku, ali i nepravilno oblikovanje ručke, ove ulomke smješta u tip LRA1 ili LRA2, s datacijom od sredine 3., odnosno u 4. te sve do 7. stoljeća (ADS Roman amphorae Late Roman Amphora 1, Late Roman Amphora 2). Na Kvarneru su ove amfore zabilježene u podmorju Raba, Lošinja i u uvali Mala luka na Krku (Dautova Ruševljan 1970: 165)

Neidentificirane amfore (T. 4, tab. 4)

Nekoliko ulomaka ruba, ručka, vrata i dna pokazali su se premalih dimenzija ili nedovoljno specifičnog oblika za precizno određivanje tipa, no u nekoliko je slučajeva bilo moguće pretpostaviti provenijenciju na osnovi keramičke strukture (vidi tab. 4). Izdvajamo ulomke ruba i dna N-101-5 (T. 4: 8) i N-101-6 (T. 4: 16) koji bi mogli pripadati istoj posudi zbog istovjetne strukture.

Rim shard N-131-23 (Pl. 2: 7) is attributed to the typology of Keay 62 amphorae, which includes a number of subtypes, however, due to the small size of the shard we were unable to define it with greater precision. We have therefore put forward a somewhat wider date covering the period from the end of the 5th cent. to the beginning of the 7th cent. (Bonifay 2004: 137–160). We do not know which foodstuffs were transported in these amphorae, although wine and *salsamenta* are presumed for one of the variants (Bonifay 2004: 474).

Rim N-16-2 (Pl. 2: 8) is a type that we would attribute to the Bonifay 64 – 66 group (Bonifay 2004: 151–153). These are the so-called globular amphorae (*anfore globulari*, *anfore tipo Castrum Perti*, *amphore globulaire*), which are dated between the 6th and 8th cent. and considered as Byzantine developments of certain LRA and African types, whose production is positioned in the Eastern Mediterranean as much as in North Africa and Italy (Italian production has been documented especially in the south of the peninsula, with the *Crypta Balbi* as one of the most common types). The exact type of our specimen is difficult to determine, but it probably belongs to the African production, due to which, instead of aligning it with LRA 2 or 13 types, we would rather compare it with types of wine amphorae from Carthage (Bonifay 2004: 152–153, type 64/3, type 66/1, 475). However, several shards of ribbed walls of the “African” fabric observed within the assemblage might also be connected with the globular amphorae type. In addition to the mentioned shards, morphological but also structural similarity exists with a shard of indeterminate amphora from the S. Andrea Island (Marano (UD) (Villa 1998: 227–229, Fig. 2: 10), as well as with shard *Ostia IV*, 284, which also features a yellowish slip (Manacorda 1977: 127, Fig. 284). It deserves a special mention that rims of these specimens are nevertheless somewhat different, even though the handles connect to the neck in an almost identical way. Different types of globular amphorae are present in the Upper Adriatic and Northern Italy (Gelichi et al. 2006; Gelichi, Negrelli 2008: 314–323; Cirelli 2009).

To African amphorae, based on the ceramic fabric, we would also attribute the handles, neck and bases presented in Tab. 2 and Pl. 3.

Eastern Mediterranean amphorae (Pl. 4, Tab. 3)

Potential specimens of Eastern Mediterranean amphorae were identified exclusively on the basis of fabrics, which consist of several handle shards: N-16-6 (Pl. 4: 1), N-16-7 (Pl. 4: 2) and N-1-1 (Pl. 4: 3). Bright fabric with numerous inclusions on the surface and in the cross-section, as well as irregular-shaped handles, position these shards into type LRA1 or LRA2, with dating from the mid-3rd or the 4th cent. until the 7th cent. (ADS Roman amphorae Late Roman Amphora 1, Late Roman Amphora 2). In the Kvarner Gulf these amphorae were documented in the underwater zones of the Rab and Lošinj islands and in the Mala luka cove on the Krk Island (Dautova Ruševljan 1970: 165).

Indeterminate amphorae (Pl. 4, Tab. 4)

Several rim, handle, neck and base shards were too small or had insufficiently specific shapes to precisely determine their types, however, in several cases it was possible to presume their origin based on the ceramic fabric (see Tab.

Crtež	Br. n.	SJ	Oblik ulomka / Struktura	Datacija	Analogije
T. 4: 1	N-16-6	I.3002	Ručka / Boja: 7.5yr 6/6; Primjese: površinski i u lomu vrlo česte sitne male bijele i sjajne, velike bijele, sive, crne, smeđecrvene; Rupice: česte sitne	3.–7. st.	LRA1
T. 4: 2	N-16-7	I.3002	Ručka / Boja: 10YR 7/4 površina, presjek 5YR 7/6, 7/7; Primjese: česte sitne i srednje bijele, površinski prisutne rijetke velike crvene i bijele	4.–7. st.	LRA2
T. 4: 3	N-1-1	I.3001	Ručka / Boja: 7.5Yr 6/4; Primjese: česte sitne bijele, crne i smeđe, povremene velike crvene; Rupice: česte raznih dimenzija		Istočnomediterranska amfora bliska LRA1/2
Drawing	No. f.	SU	Shard form / Fabric	Date	Analogy
Pl. 4: 1	N-16-6	I.3002	Handle / Colour: 7.5yr 6/6; Inclusions: on the surface and in the cross-section very common small white and glossy, large white, grey, black, brown-red; Holes: frequent small	3 rd -7 th century	LRA1
Pl. 4: 2	N-16-7	I.3002	Handle / Colour: 10YR 7/4 surface, cross-section 5YR 7/6, 7/7; Inclusions: frequent small and medium white, superficially present rare large red and white	4 th -7 th century	LRA2
Pl. 4: 3	N-1-1	I.3001	Handle / Colour: 7.5Yr 6/4; Inclusions: frequent small white, black and brown, occasional large red; Holes: frequent of various sizes		Eastern Mediterranean amphora similar to LRA1/2

Tab. 3 Istočnomediterranske amfore
Tab. 3 Eastern Mediterranean amphorae

Crtež	Br. n.	SJ	Oblik ulomka / Struktura	Datacija	Analogije
T. 4: 4	N-23-5	I.3002	Rub / Boja: 2.5 yr 5/8; Primjese: tamnosive, svijetlosive, sitne česte bijele		Afrička amfora?
T. 4: 5	N08-A1-4	I.2003	Rub / Boja: 2.5 YR 6/6; Primjese: rijetke sitne sjajne		
T. 4: 6	N-131-34	I.4000	Rub / Boja: 7.5YR 6/6; Primjese: povremene sitne bijele, srednje crne i crvene		
T. 4: 7	N-67-1	I.3010	Rub / Boja: 10yr 8/4; Primjese: sitne crne, rijetke sitne crvene, rijetke veće crvene; Premaz: sivkastosmeđi premaz? (10yr 5/3)		
T. 4: 8	N-101-5	I.2101	Rub / Boja: 7.5YR 6/6; Primjese: povremene sitne bijele, crne i sive		
T. 4: 9	N-101-7	I.2101	Rub / Boja: 7.5YR 6/4; Primjese: površinski vidljive povremene srednje zlatno sjajne, sive i crvenosmeđe		Istočni Mediteran?
T. 4: 10	N08-A4-5	I.2001	Rame s ručkama / Boja: 5YR 6/6; Primjese: povremene sitne bijele; Rupice: povremene sitne		Hispanija ili istočni Mediteran?
T. 4: 12	N13-A1-15		Ručka / Boja: 7.5YR 6/4; Primjese: povremene sitne bijele, sjajne i smeđe		Istočni Mediteran?
T. 4: 12	N08-A3-1	I.2013	Vrat i ručke / Boja: 5YR 7/6; Primjese: česte sitne crne, povremene sitne sjajne, povremene sitne i velike crvene		Italaska / jadranska proizvodnja?
T. 4: 13	N-60-1	I.3019	Ručka / Boja: 2.5YR 6/8, 5/8; Primjese: rijetke bijele srednje, povremene sitne sjajne, rijetke sitne crne		Italaska / jadranska proizvodnja?
T. 4: 14	N-39-9	I.3002	Ručka / Boja: 2.5YR 5/8; Primjese: povremene bijele srednje, povremene sitne sjajne, česte sitne i srednje crne		Italaska / jadranska proizvodnja?
T. 4: 15	N-5-2	I.3002	Ručka / Boja: 10YR 7/4; Primjese: povremene sitne crne		
T. 4: 16	N-101-6	I.2101	Dno / Boja: 7.5YR 6/6; Primjese: povremene sitne bijele, crne i sive		Struktura kao N-101-5
T. 4: 17	N-5-5	I.3002	Dno / Boja: 5YR 6/6; Primjese: povremene sitne sive		
T. 4: 18	N-131-27	I.4000	Dno / Boja: 7.5YR 6/6; Primjese: povremene sitne bijele i srednje crvene; Rupice: povremene		
T. 4: 19	N-16-5	I.3002	Dno / Boja: 2.5YR 5/2; Primjese: vrlo česte sitne bijele, velike bijele i crvene (povremeno se javljaju "nakupine" kamenčića – pijeska)		Istočni Mediteran?
T. 4: 20	N-74-1	I.3008	Dno / Boja: 2.5Y 8/2; Primjese: povremene sitne crne, smeđe i sjajne		

Tab. 4 Neidentificirane amfore

Drawing	No. f.	SU	Shard form / Fabric	Date	Analogy
Pl. 4: 4	N-23-5	I.3002	Rim / Colour: 2.5 yr 5/8; Inclusions: dark grey, light grey, small frequent white		African amphora?
Pl. 4: 5	N08-A1-4	I.2003	Rim / Colour: 2.5 YR 6/6; Inclusions: rare small glossy		
Pl. 4: 6	N-131-34	I.4000	Rim / Colour: 7.5YR 6/6; Inclusions: occasional small white, medium black and red		
Pl. 4: 7	N-67-1	I.3010	Rim / Colour: 10yr 8/4; Inclusions: small black, rare small red, rare larger red; Slip: greyish-brown slip? (10yr 5/3)		
Pl. 4: 8	N-101-5	I.2101	Rim / Colour: 7.5YR 6/6; Inclusions: occasional small white, black and grey		
Pl. 4: 9	N-101-7	I.2101	Rim / Colour: 7.5YR 6/4; Inclusions: superficially visible occasional medium gold glossy, grey and red-brown		Eastern Mediterranean?
Pl. 4: 10	N08-A4-5	I.2001	Shoulder with handles / Colour: 5YR 6/6; Inclusions: occasional small white; Holes: occasional small		Hispania or Eastern Mediterranean?
Pl. 4: 12	N13-A1-15		Handle / Colour: 7.5YR 6/4; Inclusions: occasional small white, glossy and brown		Eastern Mediterranean?
Pl. 4: 12	N08-A3-1	I.2013	Neck and handles / Colour: 5YR 7/6; Inclusions: frequent small black, occasional small glossy, occasional small and large red		Italic / Adriatic production?
Pl. 4: 13	N-60-1	I.3019	Handle / Colour: 2.5YR 6/8, 5/8; Inclusions: rare white medium, occasional small glossy, rare small black		Italic / Adriatic production?
Pl. 4: 14	N-39-9	I.3002	Handle / Colour: 2.5YR 5/8; Inclusions: occasional white medium, occasional small glossy, frequent small and medium black		Italic / Adriatic production?
Pl. 4: 15	N-5-2	I.3002	Handle / Colour: 10YR 7/4; Inclusions: occasional small black		
Pl. 4: 16	N-101-6	I.2101	Base / Colour: 7.5YR 6/6; Inclusions: occasional small white, black and grey		Fabric like N-101-5
Pl. 4: 17	N-5-5	I.3002	Base / Colour: 5YR 6/6; Inclusions: occasional small grey		
Pl. 4: 18	N-131-27	I.4000	Base / Colour: 7.5YR 6/6; Inclusions: occasional small white and medium red; Holes: occasional		
Pl. 4: 19	N-16-5	I.3002	Base / Colour: 2.5YR 5/2; Inclusions: very frequent small white, large white and red (occasional appearance of "heaps" of small stones – sand)		Eastern Mediterranean?
Pl. 4: 20	N-74-1	I.3008	Base / Colour: 2.5Y 8/2; Inclusions: occasional small black, brown and glossy		

Tab. 4 Indeterminate amphorae

Čepovi za amfore (T. 5, tab. 5)

Unutar materijala s Foruma sa sigurnošću je identificirano sedam čepova za amfore, od kojih su tri oblikovana u kalupu (N08-A5-1, N-131-20, N-131-21) (T. 5: 1–3), četiri od stijenki amfore (N-131-19, N-34-1, N-9-1) (T. 5: 4, 7, 5) ili drugih posuda (N13-A1-4) (T. 5: 6), a samo je N08-A5-1 (T. 5: 1) ukrašen zrakastim reljefnim motivom. Za klasifikaciju čepova korištene su tri grupe prema tipologiji M. Buore, S. Magnanija, G. F. Rosseta (Buora et al. 2012/13) koji su dopunili tipologiju R. Chinelli za čepove iz Akvileje (Chinelli 1991; 1994).

Posebno se ističe predmet N08-A1-4 (T. 5: 8) koji interpretiramo kao čep amfore s obzirom na morfološke karakteristike i dimenzije. Riječ je o čepu/poklopcu nepravilnoga kružnog oblika koji se s donje strane u sredini izdiže tvoreći udubljenje, dok je s gornje strane prisutna nepravilno oblikovana, kružna ručka s nepravilnim žlijebom po sredini. Na gornjem dijelu ručke također je prisutno manje dublje udu-

4). We single out rim and base shards N-101-5 (Pl. 4: 8) and N-101-6 (Pl. 4: 16), which might belong to the same vessel due to the identical fabric.

Amphorae stoppers (Pl. 5, Tab. 5)

A total of seven stoppers for amphorae, three of which were mold-shaped, were identified with certainty within the assemblage from the Forum (N08-A5-1, N-131-20, N-131-21) (Pl. 5: 1–3); four were made of walls of amphorae (N-131-19, N-34-1, N-9-1) (Pl. 5: 4, 7, 5) or other types of pots (N13-A1-4) (Pl. 5: 6), while only N08-A5-1 (Pl. 5: 1) was decorated with a radial motif in relief. For the classification of the stoppers we used three groups based on the typology of M. Buora, S. Magnani, G. F. Rosset (Buora et al. 2012/13), who supplemented R. Chinelli's typology for the stoppers from Aquileia (Chinelli 1991; 1994).

Object N08-A1-4 (Pl. 5: 8) stands out in particular. We have interpreted it as an amphora stopper due to its morp-

Crtež	Br. n.	SJ	Oblik ulomka / Tip – struktura	Datacija	Analogije
T. 5: 1	N08 - A5 - 1	I.2002	Čep oblikovan u kalupu, grupa I tip Ab sa zrakastim reljefnim motivom / Boja: 7.5YR 8/4; Rupice: česte sitne	Kraj 1. st. pr. Kr. – prva pol. 1. st.	Rinaldi et al. 2012/13: 73, tav. 1–9; Dobрева, Luise 2012/13: 88, 90, Fig. 9–59
T. 5: 2	N-131-20	I.4000	Čep oblikovan u kalupu, grupa I / Boja: 2.5Y 7/4; Rupice: česte sitne		Sermin, tip PA 8 (Horvat 1997: 77–82, T. 24: 26)
T. 5: 3	N-131-21	I.4000	Čep oblikovan u kalupu, grupa I / Boja: 5YR 7/6; Primjese: česte sitne bijele, povremene sitne crvene		
T. 5: 4	N-131-19	I.4000	Čep oblikovan od stijenke amfore, grupa III / Boja: 10YR 7/4; Primjese: povremene sitne bijele, povremene sitne crvene, povremene veće smeđe		
T. 5: 5	N-9-1	I.3003	Čep oblikovan od stijenke afričke amfore, grupa III / Boja: 5YR 5/2; Primjese: česte sitne bijele i svijetlosmeđe, povremene crvene različitih dimenzija, povremene srednje sjajne sivobijele	2.–7. st.	Od stijenki afričke amfore
T. 5: 6	N13 - A1 - 4	I.2100; I.2101; I.2103;	Čep oblikovan od stijenke posude, grupa III / Boja: 5YR 7/6; Primjese: sitne bijele, povremene sitne crne, rijetke veće crvene		
T. 5: 7	N-34-1	I.3010	Čep oblikovan od narebrene stijenke amfore, grupa III / Boja: 10YR 6/4; Primjese: česte malo bijele, srednje i velike crne; Rupice: izrazito česte	3.–7. st.	Od stijenki istočno-mediteranske amfore
T. 5: 8	N08-A1-4	I.2003	Čep oblikovan na kolu?, grupa II / Boja: 7.5YR 6/6; Primjese: sitne bijele i sjajne, srednje sjajne i pokoja sitna crna primjesa		
Drawing	No. f.	SU	Shard form / Type – Fabric	Date	Analogies
Pl. 5: 1	N08 - A5 - 1	I.2002	Mould-shaped stopper, group I type Ab with radial relief motif / Colour: 7.5YR 8/4; Holes: frequent small	End of 1 st century BC – first half of 1 st century AD	Rinaldi et al. 2012/13: 73, tav. 1–9; Dobрева, Luise 2012/13: 88, 90, Fig. 9–59
Pl. 5: 2	N-131-20	I.4000	Mould-shaped stopper, group I / Colour: 2.5Y 7/4; Holes: frequent small		Sermin, tip PA 8 (Horvat 1997: 77–82, T. 24: 26)
Pl. 5: 3	N-131-21	I.4000	Mould-shaped stopper, group I / Colour: 5YR 7/6; Inclusions: frequent small white, occasional small red		
Pl. 5: 4	N-131-19	I.4000	Stopper shaped out of an amphora wall, group III / Colour: 10YR 7/4; Inclusions: occasional small red, occasional larger brown		
Pl. 5: 5	N-9-1	I.3003	Stopper shaped out of an African amphora wall, group III / Colour: 5YR 5/2; Inclusions: frequent small white and light brown, occasional red of various sizes, occasional medium glossy grey-white	2 nd -7 th century	Made out of a wall of an African amphora
Pl. 5: 6	N13 - A1 - 4	I.2100; I.2101; I.2103;	Stopper shaped out of a vessel wall, group III / Colour: 5YR 7/6; Inclusions: small white, occasional small black, rare larger red		
Pl. 5: 7	N-34-1	I.3010	Stopper shaped out of a ribbed amphora wall, group III / Colour: 10YR 6/4; Inclusions: frequent small white, medium and large black; Holes: extremely common	3 rd -7 th century	Made out of a wall of an Eastern Mediterranean amphora
Pl. 5: 8	N08-A1-4	I.2003	Wheel-made stopper, group II / Colour: 7.5YR 6/6; Inclusions: small white and glossy, medium glossy and a few small black inclusions		

Tab. 5 Čepovi za amfore
Tab. 5 Amphora stoppers

bljenje koje možda prolazi kroz središnji dio predmeta tvo- reći rupicu. Preciznijih analogija nema, iako je čep vjerojat- no izrađen na kolu, prema čemu pripada tipu II iz Akvileje.

Ova vrsta materijala ne dozvoljava preciznije datacije, no možemo utvrditi da se čepovi izrađeni u kalupu datiraju od 1. st. pr. Kr. pa sve do 2. stoljeća, dok se oni izrađeni od stijenki amfora javljaju već u kontekstima s grčko-italskim amforama (Horvat 1997: 81), no ipak se u pojedinim slučajje- vima mogu nešto preciznije datirati prema strukturi, a pro- težu se sve do u kasnu antiku.

Fino stolno posuđe

U kategoriju finoga stolnog posuđa smještamo sve tipove sigilatnog posuđa, keramiku tankih stijenki, *Pannonische Glanztonware* i glazirano posuđe (za omjere vidjeti graf 2). Brojni primjerci italske *terre sigillate* (ITS) te još brojniji pri- mjerci keramike tankih stijenki (KTS) uglavnom su izrazito fragmentarni. Originalni slojevi kojima bismo mogli pripisati ovaj materijal većinom su destruirani još u antici (Čau- šević-Bully, Valent 2015: 129-139), a dio ranocarskoga finog stolnog posuđa jest rezidualni materijal.

Italska terra sigillata (ITS, T. 6, tab. 6)

Ulomci ITS uglavnom su vrlo malih dimenzija, izliza- nih lomova i ponekad vrlo loše sačuvanog premaza. Tako je od 57 ulomaka oblik definiran za 13 ulomaka. Ukupno, ulomci većinom pripadaju sjevernoitalskoj, dok je tek za četiri ulomka pretpostavljena srednjoitalska proizvodnja (rub N08-A5-42, N08-A5-2, N08-A5-3 (T. 6: 2, 1, 5), stijenke N-117-12-14). Takva se pripadnost u potpunosti poklapa s dosadaš- njim saznanjima o ovoj keramičkoj vrsti na Kvarneru (Makja- nić 1987: 233; 1988: 91).

Za dataciju su korištene gotovo isključivo morfološke karakteristike posuda (ustanovljene prema Ettlinger et al.

hological features and size. This is a stopper/lid of irregular circular shape, with a concavity in the middle of the base and an uneven round handle on top, with an irregular groove running along the middle of the handle. There is another small and deep depression on top of the handle, which may have passed through the middle of the object, forming a hole. There is no precise analogy for the object, although it was presumably made on a wheel, due to which we may attribute it to type II from Aquileia.

Although this type of material does not lend itself well to precise dating, we can nevertheless state that mold- shaped stoppers are dated from the 1st cent. BC until the 2nd cent. AD, while those made from amphorae walls make their appearance already in contexts with Greco-Italic amp- horae (Horvat 1997: 81). In certain cases they can be dated with a somewhat greater precision based on the fabric, and they continue in use until late antiquity.

Fine tableware

We included in this category all types of sigillata wares, thin-walled pottery, *Pannonische Glanztonware* and glazed pottery (for the ratios see graph 2). The abundant remains of Italic *terra sigillata* (ITS) and even more abundant speci- mens of thin-walled pottery (TWP) are mostly extremely fragmented. The original layers to which we could attribute this material were by and large destroyed already in antiquity (Čaušević-Bully, Valent 2015: 129-139), and a part of the early imperial fine tableware assemblage may be interper- ted as residual.

Italic terra sigillata (ITS, Pl. 6, Tab. 6)

ITS shards are mostly of very small size, with worn bre- aks and occasionally very poorly preserved slip. Thus, the form has been determined for 13 out of 57 shards. On the whole, the shards mostly belong to northern Italic producti- on, while central Italic production is presumed for only four shards (rims N08-A5-42, N08-A5-2, N08-A5-3 (Pl. 6: 2, 1, 5), walls N-117-12-14). Such an attribution fully coincides with

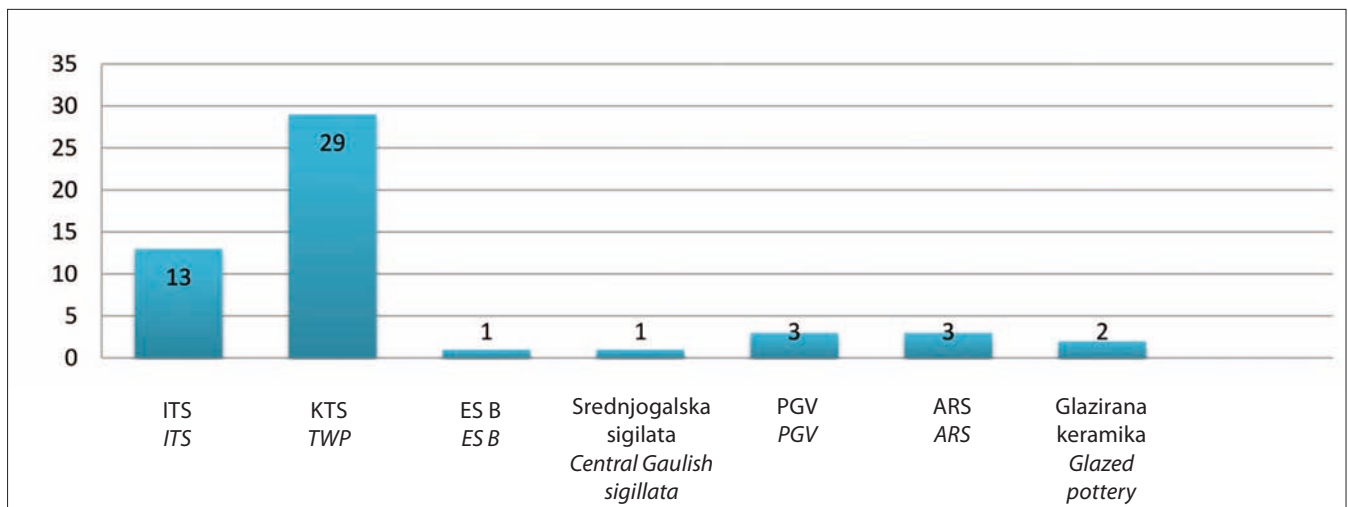

Graf. 2 Fino stolno posuđe: procijenjeni broj posuda prema vrsti (ITS = italska terra sigillata, KTS = keramika tankih stijenki, ES B = Eastern sigillata B, PGW = *Pannonische Glanztonware*, ARS = African Red Slip Ware)

Graph 2 Fine tableware: estimated number of vessels by type (ITS = *Italic terra sigillata*, TWP = thin-walled pottery, ES B = Eastern sigillata B, PGW = *Pannonische Glanztonware*, ARS = African Red Slip Ware)

Crtež	Br. n.	SJ	Oblik / Produkcija	Datacija
T. 6: 1	N08-A5-2	I.2002	Dno – četvrtasto pečatno polje OCK 190.2, 116.7, 94.6 / Srednjoitalska	20./15 g. pr. Kr. – kasno Augustovo doba
T. 6: 2	N08-A5-42	I.2002	Consp. 8.2 / Srednjoitalska	Početak 1. st.
T. 6: 3	N08-A5-37	I.2002	Consp. 21.3 / Sjevernoitalska	Kasno Augustovo doba – 30. po. Kr.
T. 6: 4	N-123-1	I.2115	Consp. B 4.13 (Consp. 23?) – <i>planta pedis</i> RVFI (OCK 1738, 1739) / Sjevernoitalska	Od (15.) 30 g. po. Kr.
T. 6: 6	N08-A5-41	I.2002	Consp. 18.2 / Sjevernoitalska	August – Tiberije
T. 6: 8	N-117-2	I.2		
T. 6: 10	N-131-1,2	I.4000	Consp. B 1.10 / Sjevernoitalska	August – Tiberije
T. 6: 7	N-60-2	I.3019	Consp. 27.3 / Sjevernoitalska	Tiberije – Neron
T. 6: 5	N08-A5-3	I.2002	Consp. 20.4 / Srednjoitalska	Pol. 1. st.
T. 6: 11	N08-A5-4	I.2002	Consp. 20.4 / Sjevernoitalska	Pol. 1. st.
T. 6: 12	N-98-3	I.2101	Consp. 20.4.3 / Sjevernoitalska	Pol. 1. st.
T. 6: 13	N-131-4	I.4000	Cons. 6.2.1 / Sjevernoitalska	Pol. 1. st.
T. 6: 9	N-117-3	I.2	Consp. B.3.12 / Sjevernoitalska	Kasno Tiberijevo doba – <i>tardopadana</i>
Drawing	No. f.	SU	Form / Production	Date
Pl. 6: 1	N08-A5-2	I.2002	Base – rectangular stamp field OCK 190.2, 116.7, 94.6 / Central Italic	20/15 BC – late Augustan period
Pl. 6: 2	N08-A5-42	I.2002	Consp. 8.2 / Central Italic	Beginning of the 1 st century
Pl. 6: 3	N08-A5-37	I.2002	Consp. 21.3 / Northern Italic	Late Augustan period – 30 AD
Pl. 6: 4	N-123-1	I.2115	Consp. B 4.13 (Consp. 23?) – <i>planta pedis</i> RVFI (OCK 1738, 1739) / Northern Italic	From AD (15) 30
Pl. 6: 6	N08-A5-41	I.2002	Consp. 18.2 / Northern Italic	Augustus – Tiberius
Pl. 6: 8	N-117-2	I.2		
Pl. 6: 10	N-131-1,2	I.4000	Consp. B 1.10 / Northern Italic	Augustus – Tiberius
Pl. 6: 7	N-60-2	I.3019	Consp. 27.3 / Northern Italic	Tiberius – Nero
Pl. 6: 5	N08-A5-3	I.2002	Consp. 20.4 / Northern Italic	mid-1 st century
Pl. 6: 11	N08-A5-4	I.2002	Consp. 20.4 / Northern Italic	mid-1 st century
Pl. 6: 12	N-98-3	I.2101	Consp. 20.4.3 / Northern Italic	mid-1 st century
Pl. 6: 13	N-131-4	I.4000	Cons. 6.2.1 / Northern Italic	mid-1 st century
Pl. 6: 9	N-117-3	I.2	Consp. B.3.12 / Northern Italic	Late Tiberian period – <i>tardopadana</i>

Tab. 6 Italska terra sigillata (ITS)

Tab. 6 *Italic terra sigillata* (ITS)

1990⁶) jer su pečati uočeni na tek dva primjerka. Riječ je o dnu zdjelice N-123-1 (T. 6: 4/1a) oblika Consp. B 4.13 (oblik Consp. 23?) s pečatom RVFI *in planta pedis* (OCK 1738, Rvfvs), koji se najranije javlja od 30. godine po. K., no s obzirom na fragmentarnu sačuvanost pečata, valja uzeti u obzir i sličnost s OCK 1739.6, što bi dataciju pomaknulo ranije, oko 15 god. pos. Kr. Pečat tipa OCK 1738 poznat je i iz Osora (Makjanić 1985: 43, T. 3: 29, T. 7: 29), gdje se nalazi na tanjuru Consp. 20.4.3.

Drugi je ulomak dna, vjerojatno srednjoitalske proizvodnje N08-A5-2 (T. 6: 1), na kojem je vidljiv četverokutni okvir pečatnog polja sa sačuvanim prvim slovom – A. Prema oblikovanju slova kojem nedostaje poprečna crtica, te zbog atribucije srednjoitalskoj TS, možemo predložiti analogiju s pečatima OCK 190.2 (Afer – Sex. Annivs Afer), 116.7 (Annivs) i 94.6 (Anch(arivs)). Zbog oblika pečatnog polja ovaj bismo ulomak mogli okvirno smjestiti u razdoblje od 20. god. pr. Kr. do 15.–20. god. pos. Kr., nakon kojeg počinje masovno

our knowledge about this pottery type in the Kvarner Gulf (Makjanić 1987: 233; 1988: 91).

For dating we used almost exclusively the morphological features of pottery (determined after Ettliger et al. 1990⁶), because stamps were noted on merely two specimens. The first is the bowl base N-123-1 (Pl. 6: 4/1a) of the form Consp. B 4.13 (form Consp. 23?) with stamp RVFI *in planta pedis* (OCK 1738, Rvfvs), which first appeared starting with AD 30, however, taking into consideration the fragmented state of the stamp we ought to also consider the resemblance to OCK 1739.6, which would shift the dating to an earlier time, around AD 15. Stamp of type OCK 1738 is known also from Osor (Makjanić 1985: 43, Pl. 3: 29, Pl. 7: 29), where we find it on a Consp. 20.4.3 plate.

The other specimen is the base shard N08-A5-2 (Pl. 6: 1), presumably made in central Italy, with a rectangular frame of the stamp area with the preserved initial letter – A. Based on the shape of the letter, missing the transverse bar, and

⁶ Za definiciju tipova koristit će se kratica Consp. (= Ettliger et al. 1990), koja je ustaljena za ovu keramičku vrstu, dok će se za pečate koristiti kratica OCK (= Oxè et al. 2000).

⁶ For defining types we shall use the abbreviation Consp. (= Ettliger et al. 1990), usual for this pottery type, while for stamps we shall use the abbreviation OCK (= Oxè et al. 2000).

korištenje *in planta pedis* pečata (Ettinger et al. 1990: 147–148; Oxè et al. 2000: 36), dok bi prema predloženim identifikacijama pečata najraniji datum pomaknuli na 15. god. pr. Kr. (OCK 116.7).

Ostali se ulomci ne ističu individualnim posebnostima, no možemo zaključiti kako prema ulomcima koji su tipološki određivi daleko prednjače oblici Consp. 20.4 i 18.2 koji i inače, uz Consp. 21, odgovaraju vrlo rasprostranjenijim oblicima ITS (Ettinger et al. 1990: 82, 86, 88), a vrlo su česti na kvarnerskom području uopće (Makjanić 1987: Fig. 1).

Valjda napomenuti da većina ulomaka ITS dolazi iz SJ I.2002 koji se smješta na prostoru bazilike, a ulomak N-123-1 (Pl. 6: 4/1a) posebno je zanimljiv i zato što potječe iz zapune rova za izgradnju zida bazilike (vidjeti Čaušević-Bully, Valent 2015).

Istočna sigillata B (ES B, T. 7, tab. 7)

Jedan ulomka, N08-A5-27 (T. 7: 1), pripada istočnome-diteranskoj proizvodnji sigilatnog posuđa, *Eastern sigillata*, i to tipu B II, odnosno zdjelici Hayes 74 (Hayes 1985, T. XV: 7). Ovaj se oblik ES B datira od 70.–75. do 125. god. pos. Kr. Na Kvarneru je ovaj oblik dosad poznat iz Osora i Bakra (Makjanić 1983: T. 2: 10, 8), dok je ES B prisutna još u Rijeci, Krku, na Iloviku te u samom *Fulfinumu*, a česta je i u Istri te duž istočne obale Jadrana (Makjanić 1983: 51–52; Maggi 2006: Fig. 6, Tab. 2).

Crtež	Br. n.	SJ	Oblik / Struktura	Datacija	Analogija
T. 7: 1	N08-A5-27	I.2002	Zdjelica Forma 75 / ES B II	70./75.–125. g.	Hayes 74 (Hayes 1985, T. XV: 7)
Drawing	No. f.	SU	Form / Fabric	Date	Analogy
Pl. 7: 1	N08-A5-27	I.2002	Bowl Form 75 / ES B II	AD 70/75 – 125	Hayes 74 (Hayes 1985, T. XV: 7)

Tab. 7 Istočna sigilata B (ES B)

Tab. 7 *Eastern sigillata B (ES B)*

Afrička sigilata (ARS, T. 7, tab. 8)

Afričkom sigilatnom posuđu (*African Red Slip Ware*) pripadaju tri ulomka tanjura i zdjelica koje smještamo unutar A i D proizvodnji. Najraniji ulomak N-138-2 (T. 7: 2), vrlo loše sačuvan, pripada tipu Hayes 14A, a kronološki se smješta od polovine 2. stoljeća (Bonifay 2004: 157–159), dok se oba ulomka D proizvodnje, N-5-7 (Hayes 67) (T. 7: 3) i N-39-2 (Hayes 58B) (T. 7: 4), kronološki smještaju između 4. i 5. stoljeća.

Iz istraživanja u *Fulfinumu* 70-ih godina prošlog stoljeća potječe ulomak ARS oblika Hayes 50B koji također datira u razdoblje kraja 4. do početka 5. stoljeća (Pavišić 1983: 44, T. I: 5), a primjerci ARS česti su i na drugim kvarnerskim lokalitetima, iako su zasad objavljeni samo oni iz Baške (Bekić, Višnjić, 2008: 232), Tarsatike (Percan 2009: 69–98; Starac, R. 2004: 27–28, tab. IV: 1, VII) i Senja (Fadić 1988: 63; Starac, R. 1999: 75, T. 1: 2–5, 13).

Galska terra sigillata (T. 7, tab. 9)

Dno N-39-3 (T. 7: 5) s prstenastom nogom i profilacijom na prijelazu prema trbuhu identificirano je kao proizvod srednjogalske radionice Lezoux. Riječ je o dnu koje najvjerojatnije pripada tanjuru ili većoj zdjeli s niskom nožicom

on the attribution to central Italic TS, we may put forward an analogy with stamps OCK 190.2 (Afer – Sex. Annivs Afer), 116.7 (Annivs) and 94.6 (Anch(arivs)). The shape of the stamp area suggests an approximate dating for the shard into the period from 20 BC until AD 15–20, the date which marks the beginning of the widespread use of the *in planta pedis* stamps (Ettinger et al. 1990: 147–148; Oxè et al. 2000: 36), while the earliest possible date, based on the proposed identifications of the stamp, may be shifted to the year 15 BC (OCK 116.7).

The remaining shards do not stand out by any distinct traits, although we may conclude that, based on typologically diagnostic shards, by far the most common forms are Consp. 20.4 and 18.2, which also otherwise, alongside Consp. 21, match the widely distributed ITS forms (Ettinger et al. 1990: 82, 86, 88), and which are generally very common in the Kvarner Gulf (Makjanić 1987: Fig. 1).

We ought to mention that most ITS shards come from SJ I.2002, situated in the basilica area, while shard N-123-1 (Pl. 6: 4/1a) is particularly interesting also because it comes from the backfill of a foundation trench for a wall of the basilica (see Čaušević-Bully, Valent 2015).

Eastern sigillata B (ES B, Pl. 7, Tab. 7)

One shard, N08-A5-27 (Pl. 7: 1), belongs to the Eastern Mediterranean production of sigillata ware, *Eastern sigillata*,

more precisely its type B II, that is, a bowl of type Hayes 74 (Hayes 1985, T. XV: 7). This ES B type is dated from AD 70–75 to 125. In the Kvarner Gulf this type has so far been known from Osor and Bakar (Makjanić 1983: Pl. 2: 10, 8), while ES B is present also in Rijeka, on Krk Island, on Ilovik Island and in *Fulfinum* itself, while it is also common in Istria and along the eastern coast of the Adriatic Sea (Makjanić 1983: 51–52; Maggi 2006: Fig. 6, Tab. 2).

African sigillata (ARS, Pl. 7, Tab. 8)

To African sigillata (*African Red Slip Ware*) belong three shards of plates and a small bowl, attributed to A and D productions. The earliest shard, N-138-2 (Pl. 7: 2), very poorly preserved, belongs to type Hayes 14A, dated from the mid-2nd cent. (Bonifay 2004: 157–159), while both shards of D production, N-5-7 (Hayes 67) (Pl. 7: 3) and N-39-2 (Hayes 58B) (Pl. 7: 4), fall between the 4th and 5th cent..

The excavations in *Fulfinum* in the 1970s yielded an ARS shard of Hayes 50B form, likewise dated to the period between the end of the 4th and the beginning of the 5th cent. (Pavišić 1983: 44, Pl. I: 5). ARS shards are common also at other sites in the Kvarner Gulf, even though only those from Baška (Bekić, Višnjić 2008: 232), Tarsatica (Percan 2009:

Crtež	Br. n.	SJ	Oblik / Struktura	Datacija	Analogije
T. 7: 2	N-138-2	I.2121	Zdjelica / ARSW A	Kraj. 2. st. – početak 3. st.	Hayes 14A, Bonifay type 5 (Bonifay 2004: 157–159)
T. 7: 3	N-5-7	I.3002	Rub tanjura / ARSW D	Kraj 4. st. – početak 5. st.	Hayes 67, Sigille 41 var. b (Bonifay 2004: 171–173)
T. 7: 4	N-39-2	I.3002	Rub i dno zdjelice / ARSW D	4. st.	Hayes 58 B, 32/58. Sigille type 58 (Bonifay 2004)
Drawing	No. f.	SU	Form / Fabric	Date	Analogy
Pl. 7: 2	N-138-2	I.2121	Small bowl / ARSW A	End of 2 nd – beginning of 3 rd century	Hayes 14A, Bonifay type 5 (Bonifay 2004: 157–159)
Pl. 7: 3	N-5-7	I.3002	Plate rim / ARSW D	End of 4 th – beginning of 5 th century	Hayes 67, Sigille 41 var. b (Bonifay 2004: 171–173)
Pl. 7: 4	N-39-2	I.3002	Rim and base of small bowl / ARSW D	4 th century	Hayes 58 B, 32/58. Sigille type 58 (Bonifay 2004)

Tab. 8 Afrička sigilata (ARS)

Tab. 8 African sigillata (ARS)

i konkavnim stijenkama. Prema strukturi, mogli bismo ga pripisati Fabrikatu 3, a s obzirom na oblik noge možda i posudi tipa Bet 91 (Delage 2010: 115, 118–119), odnosno 5. fazi Lezouxa prema Betu, Fenetu, Montineriju (Bet, Fenet, Montineri 1989) koja odgovara godinama od 110. do 140. Srednjogalska sigilata na Kvarneru prisutna je u Senju (Štela), s jednim ulomkom čaše tipa Bet 102 koja datira od kraja 2. do sredine 3. stoljeća (Konestra 2013).

Keramika tankih stijenki (KTS, T. 8, tab. 10)

Keramika tankih stijenki mahom pripada sivoj, dakle sjevernoitalskoj ili jadranskoj proizvodnji, a javlja se u različitim strukturama (fabrikatima), definiranim prema Schindler Kaudelka 1975.

Prvu, najbrojniju grupu čine ulomci ravnih ili tek lagano naglašenih prstenastih dna grube strukture koje smještamo u Fabrikate B i C, odnosno tipološki bismo ih mogli poistovjetiti sa zdjelicama oblika Schindler Kaudelka 50 i 68 (Schindler Kaudelka 1975: T. 10: 13–14), iako je na osnovi dna teško odrediti točan oblik. Prema navedenim analogijama, ovi se ulomci datiraju u vrijeme Augusta i Tiberija.

Dругu grupu tvore primjerci pročišćene strukture s crnim ili sivim premazom (Fabrikati D i E) bez ukrasa ili s barbotin stiliziranim ukrasom (Schindler Kaudelka 1975: T. 10: 13–14). I u ovom je slučaju poglavito riječ o zdjelicama i šalicama (u slučaju postojanja ručke). Barbotin ukras javlja se na četiri primjerka ruba zdjelice:

- N-101-1 (T. 8: 28): unutar dva reda točkica ukras spojenih grančica s pupoljkom (Sena Chiesa 1985: 403, T. 82: 15);
- N- 53-1 (T. 8: 29): ukras niza točkica u najmanje dva reda, unutar polja definiranih okvirom (nije pronađena precizno)

69–98; Starac, R. 2004: 27–28, tab. IV: 1, VII) and Senj (Fadić 1988: 63; Starac, R. 1999: 75, Pl. 1: 2–5, 13) were published so far.

Gaulish terra sigillata (Pl. 7, Tab. 9)

Base N-39-3 (Pl. 7: 5) with annular foot and profilation at the transition to the belly has been identified as a product of the workshop in Lezoux in central Gaul. This base most likely belongs to a plate or a large bowl with low foot and concave walls. Based on its fabric we might attribute it to Fabric 3, and based on the shape of the foot perhaps also to a Bet 91 type pot (Delage 2010: 115, 118–119), that is, phase 5 of Lezoux after Bet, Fenet, Montineri (Bet, Fenet, Montineri 1989), which corresponds to the years AD 110–140. Central Gaulish sigillata is present in the Kvarner Gulf in Senj (Štela) with a shard of a Bet 102 type cup, dated from the end of the 2nd to the mid-3rd cent. (Konestra 2013).

Thin-walled pottery (TWP, Pl. 8, Tab. 10)

Thin-walled pottery by and large belongs to the grey, i.e. northern Italic or Adriatic production. It appears in a number of fabrics defined after Schindler Kaudelka 1975.

The first, most common group consists of shards of flat or only slightly pronounced annular pedestals of coarse fabric, which we classified as Fabrics B and C, in other words, in terms of typology we might identify them with small bowls of Schindler Kaudelka 50 and 68 forms (Schindler Kaudelka 1975: Pl. 10: 13–14), even though the precise shape is difficult to determine based solely on the shape of the base. The mentioned analogies allow us to date these shards to the time of Augustus and Tiberius.

Crtež	Br. n.	SJ	Oblik / Struktura	Datacija	Analogije
T. 7: 5	N-39-3	I.3002	Zdjela-tanjur / Lesoux f. 3	Prva pol. 2. st.	Bet 91 (Bet, Fenet, Montineri 1989: 47)
Drawing	No. f.	SU	Form / Fabric	Date	Analogy
Pl. 7: 5	N-39-3	I.3002	Bowl-plate / Lesoux f. 3	First half of 2 nd century	Bet 91 (Bet, Fenet, Montineri 1989: 47)

Tab. 9 Galska sigilata

Tab. 9 Gaulish sigillata

Crtež	Br. n.	SJ	Oblik / Fabrikat	Datacija	Analogija
T. 8: 1	N-107	I.2101	Dno / F. B, form 50?	August – Tiberije	Schindler-Kaudelka 1975: 75–77; Schindler-Kaudelka 2012a: 330–331
T. 8: 2	N-131-6	I.4000			
T. 8: 3	N-131-7	I.4000			
T. 8: 4	N-131-12	I.4000			
T. 8: 5	N-98-1	I.2101			
T. 8: 6	N-98-2	I.2101			
T. 8: 7	N-80-2	I.3012			
T. 8: 8	N-117-1	I.2			
T. 8: 9	N-124	I.2101	Dno, F. B	August – Tiberije	Schindler-Kaudelka 1975: 75–77; Schindler-Kaudelka 2012a: 330–331
T. 8: 10	N08-A5-14	I.2002	Dno, Fab. B/C	10. g. pr. Kr. – 25. g. po. Kr.	Schindler-Kaudelka 1975: 31–32; Schindler-Kaudelka 2012a: 330–331
/	N08-A5-16	I.2002	Stijenka, Fab. B/C	10. g. pr. Kr. – 25. g. po. Kr.	Schindler-Kaudelka 1975: 31–32; Schindler-Kaudelka, 2012a: 330–331
T. 8: 11	N-131-8	I.4000	Dno, F. C, form 68?	10. g. pr. Kr. – 25. g. po. Kr.	Schindler-Kaudelka 1975: 31–32; Schindler-Kaudelka, 2012a: 330–331
T. 8: 12	N-131-11	I.4000			
T. 8: 13	N-131-9,10,14	I.4000			
T. 8: 14	N-117-7	I.2			
T. 8: 15	N-143-1	I.2101	Dno, F. C	10. g. pr. Kr. – 25. g. po. Kr.	Schindler-Kaudelka 1975: 31–32; Schindler-Kaudelka 2012a: 330–331
T. 8: 16	N-90-1	I.2101	Dno, F. E	15. g. – 50. g./100. g.	Schindler-Kaudelka 1975: 33–34; Plesničar-Gec 1977: 13–20; Schindler-Kaudelka 2012a: 331
T. 8: 17	N-67-6	I.3010	Stijenka zdjelice, F. C	10. g. pr. Kr. – 25. g. po. Kr.	Schindler-Kaudelka 1975: 31–32; Schindler-Kaudelka 2012a: 330–331
T. 8: 18	N-67-5	I.3010	Rub, F. D, form 84	20.–30. g.	Schindler-Kaudelka 1975: 95–98; Schindler-Kaudelka 2012a: 330–331
T. 8: 19	N08-A5-11	I.2002			
T. 8: 20	N08-A5-10	I.2002	Rub zdjelice, Fab. D/E	25.–60. g.	Schindler-Kaudelka 1975: 95–116; Schindler-Kaudelka 2012a: 330–331
T. 8: 21	N08-A5-30	I.2002	Rub zdjelice, <i>barbotin</i> ukras, Fab. D/E	1. st.	Schindler-Kaudelka 1975: 95–116; Schindler-Kaudelka 2012a: 330–331
T. 8: 22	N-53-3	I.3014	Dno, Fab. D/E	25.–60. g.	Schindler-Kaudelka 1975: 95–116; Schindler-Kaudelka 2012a: 330–331
T. 8: 23	N08-A5-12	I.2002			
T. 8: 24	N08-A5-13	I.2002			
T. 8: 25	N08-A5-15	I.2002	Stijenka šalice, Fab. D/E	Druga pol. 1. st.	Schindler-Kaudelka 1975: 95–116; Schindler-Kaudelka 2012a: 330–331
/	N08-A5-17	I.2002	Stijenka, Fab. D/E	25.–60. g.	Schindler-Kaudelka 1975: 95–116; Schindler-Kaudelka 2012a: 330–331
/	N08-A5-18	I.2002			
T. 8: 26	N-53-2	I.3014	Rub zdjelice, Fab. E.	1. st.	Schindler-Kaudelka 1975: 33–34; Schindler-Kaudelka 2012a: 331.
T. 8: 27	N08-A5-29	I.2002	Rub zdjelice, Fab. E, form 102	35.–60. g.	Schindler-Kaudelka 1975: 108; Schindler-Kaudelka 2012a: 331.
T. 8: 28	N-101-1	I.2101	Rub zdjelice, <i>barbottine</i> ukras, F. E, form 103	35.–100. g.	Schindler-Kaudelka 1975: 110; Plesničar-Gec 1977: T. 1: 34. Schindler-Kaudelka 2012a: 331
T. 8: 29	N-53-1	I.3014	Rub zdjelice, <i>barbottine</i> ukras, F. E, form 103	35.–100. g.	Schindler-Kaudelka 1975: 110; Plesničar-Gec 1977: T. 1: 34; Schindler-Kaudelka 2012a: 331.
T. 8: 30	N-75-1	I.3002	Rub zdjelice, <i>barbottine</i> ukras, F. E	Druga pol. 1. st.	Plesničar-Gec 1977: T. 1: 35
/	N08-A5-28	I.2002	Stijenka	1. st.	
T. 8: 31	N-131-5	I.4000	Dno / Boja: 2.5YR 5/8; Primjese: česte sitne bijele; povremene srednje bijele; na djelu površine nalazi se premaz s pijeskom	1.–2. st.	

Tab. 10 Keramika tankih stijenki (KTS)

Drawing	No. f.	SU	Form / Fabric	Date	Analogy
Pl. 8: 1	N-107	I.2101	Base / F. B, form 50?	Augustus – Tiberius	Schindler-Kaudelka 1975: 75–77; Schindler-Kaudelka 2012a: 330–331
Pl. 8: 2	N-131-6	I.4000			
Pl. 8: 3	N-131-7	I.4000			
Pl. 8: 4	N-131-12	I.4000			
Pl. 8: 5	N-98-1	I.2101			
Pl. 8: 6	N-98-2	I.2101			
Pl. 8: 7	N-80-2	I.3012			
Pl. 8: 8	N-117-1	I.2			
Pl. 8: 9	N-124	I.2101	Base, F. B	Augustus – Tiberius	Schindler-Kaudelka 1975: 75–77; Schindler-Kaudelka 2012a: 330–331
Pl. 8: 10	N08-A5-14	I.2002	Base, Fab. B/C	10 BC – AD 25	Schindler-Kaudelka 1975: 31–32; Schindler-Kaudelka 2012a: 330–331
/	N08-A5-16	I.2002	Wall, Fab. B/C	10 BC – AD 25	Schindler-Kaudelka 1975: 31–32; Schindler-Kaudelka, 2012a: 330–331
Pl. 8: 11	N-131-8	I.4000	Base, F. C, form 68?	10 BC – AD 25	Schindler-Kaudelka 1975: 31–32; Schindler-Kaudelka, 2012a: 330–331
Pl. 8: 12	N-131-11	I.4000			
Pl. 8: 13	N-131-9,10,14	I.4000			
Pl. 8: 14	N-117-7	I.2			
Pl. 8: 15	N-143-1	I.2101	Base, F. C	10 BC – AD 25	Schindler-Kaudelka 1975: 31–32; Schindler-Kaudelka 2012a: 330–331
Pl. 8: 16	N-90-1	I.2101	Base, F. E	AD 15 – 50/100	Schindler-Kaudelka 1975: 33–34; Plesničar-Gec 1977: 13–20; Schindler-Kaudelka 2012a: 331
Pl. 8: 17	N-67-6	I.3010	Wall of small bowl, F. C	10 BC – AD 25	Schindler-Kaudelka 1975: 31–32; Schindler-Kaudelka 2012a: 330–331
Pl. 8: 18	N-67-5	I.3010	Rim, F. D, form 84	AD 20 – 30	Schindler-Kaudelka 1975: 95–98; Schindler-Kaudelka 2012a: 330–331
Pl. 8: 19	N08-A5-11	I.2002			
Pl. 8: 20	N08-A5-10	I.2002	Rim of small bowl, Fab. D/E	AD 25 – 60	Schindler-Kaudelka 1975: 95–116; Schindler-Kaudelka 2012a: 330–331
Pl. 8: 21	N08-A5-30	I.2002	Rim of small bowl, barbotine decoration, Fab. D/E	1 st century	Schindler-Kaudelka 1975: 95–116; Schindler-Kaudelka 2012a: 330–331
Pl. 8: 22	N-53-3	I.3014	Base, Fab. D/E	AD 25 – 60	Schindler-Kaudelka 1975: 95–116; Schindler-Kaudelka 2012a: 330–331
Pl. 8: 23	N08-A5-12	I.2002			
Pl. 8: 24	N08-A5-13	I.2002			
Pl. 8: 25	N08-A5-15	I.2002	Wall of cup, Fab. D/E	Second half of 1 st century	Schindler-Kaudelka 1975: 95–116; Schindler-Kaudelka 2012a: 330–331
/	N08-A5-17	I.2002	Wall, Fab. D/E	AD 25 – 60	Schindler-Kaudelka 1975: 95–116; Schindler-Kaudelka 2012a: 330–331
/	N08-A5-18	I.2002			
Pl. 8: 26	N-53-2	I.3014	Rim of small bowl, Fab. E.	1 st century	Schindler-Kaudelka 1975: 33–34; Schindler-Kaudelka 2012a: 331.
Pl. 8: 27	N08-A5-29	I.2002	Rim of small bowl, Fab. E, form 102	AD 35 – 60	Schindler-Kaudelka 1975: 108; Schindler-Kaudelka 2012a: 331.
Pl. 8: 28	N-101-1	I.2101	Rim of small bowl, barbotine decoration, F. E, form 103	AD 35 – 100	Schindler-Kaudelka 1975: 110; Plesničar-Gec 1977: Pl. 1: 34. Schindler-Kaudelka 2012a: 331
Pl. 8: 29	N-53-1	I.3014	Rim of small bowl, barbotine decoration, F. E, form 103	AD 35 – 100	Schindler-Kaudelka 1975: 110; Plesničar-Gec 1977: Pl. 1: 34; Schindler-Kaudelka 2012a: 331.
Pl. 8: 30	N-75-1	I.3002	Rim of small bowl, barbotine decoration, F. E	Second half of 1 st century	Plesničar-Gec 1977: Pl. 1: 35
/	N08-A5-28	I.2002	Wall	1 st century	
Pl. 8: 31	N-131-5	I.4000	Base / Colour: 2.5YR 5/8; Inclusions: frequent small white, occasional medium white; part of the surface has slip with sand	1 st -2 nd century	

Tab. 10 Thin-walled pottery (TWP)

znija analogija);

- N-75-1 (T. 8: 30): nepravilni barbotin ukrasi širokog U-oblika (nije pronađena preciznija analogija);

- N08-A5-30 (T. 8: 21): tanka zakrivljena linija, vjerojatno dio biljnog motiva (ulomak je premalih dimenzija za rekonstrukciju motiva).

Proizvodnja posuda druge grupe započinje u vrijeme Tiberija, a nastavlja sve do kraja 1. do početka 2. stoljeća. Upravo su posude analogne drugoj grupi prisutne na fulfinskoj nekropoli Kurilovo (Dautova Ruševljan 1973; Konestra 2014). KTS italske provenijencije prisutna je na nizu kvarnerskih lokaliteta (Starac, R. 1991: 222–223; Ožanić Roguljić 2011: 32–33) iako je uglavnom neobjavljena, a poznata je i iz ranijih istraživanja *Fulfinuma* (Pavišić 1983: T. 1: 1–3, T. 2), no iste tipologije posuda prisutne su duž istočne obale Jadrana, kako unutar vojnih logora tako i u civilnim naseljima (npr. Tilurij, Burnum, Pula, Narona i dr.) (Zabehlicky Scheffenegger 1979: 26–27; Matijašić 1991; Topić 2003: 190–191; Šimić-Kanaet 2010: 30–34).

Zanimljivo je napomenuti kako na Forumu nedostaju kasniji oblici KTS (2. st. pos. Kr.) karakterizirani većim dimenzijama i novim oblicima (npr. *ollette con collarino*), koji se javljaju na fulfinskoj nekropoli Kurilovo,⁷ iako bismo N-131-5 (T. 8: 31) koji ne nalazi precizne analogije, možda mogli smjestiti u kasnu fazu proizvodnje KTS.

Pannonische Glanztonware (PGW, T. 9, tab. 11)

Ova se vrsta finoga stolnog posuđa na fulfinskom forumu javlja u samo dva primjerka (N-55-1, N08-A2-1) (T. 9: 1–2) koji pripadaju istovjetnom obliku poluloptaste zdjelice sa zadebljanim i uvijenim rubom, iako se razlikuju prema strukturi i premazu. Panonska siva ili crna keramika javlja se uglavnom kroz 2. i 3. stoljeće kada se proizvodila na prostoru provincije Panonije, a oblici potječu iz lokalne tradicije ili imitiraju oblike importiranoga finog stolnog posuđa. Ulomci s foruma ne nalaze precizne morfološke analogije, no mogli bismo ih smjestiti uz slične zdjelice iz *Vindobone* i Padove (Chinelli et al. 2007: 26, Fig. 3/13), a određena je sličnost ustanovljena i s nalazom 164 iz Turopoljskog luga, čija je struktura, međutim, sasvim različita (Koščević, Makjanić 1986/87: 33, T. XVI: 164). Jedan primjerak PGW potječe iz istraživanja provedenih na području Fulfinuma sedamdesetih godina 20. stoljeća,⁸ a brojni primjerci identificirani su i na drugim kvarnerskim lokalitetima, posebice unutar nekropole sv. Marko u Baški (Bekić, Višnjic 2008: 230–231, T. 14/16, 17, 19, T. 16/54–56, 58, 59, 61?, 62; Konestra 2013).

Antička glazirana keramika (T. 9, tab. 12)

U kategoriju antičke glazirane keramike smjestili bismo tek dva vrlo sitna ulomka. Ulomak ruba N-98-22 (T. 9: 3) pripada manjem vrču ili čaši (npr. Maccabruni 1976: 63–65, Fig. 5; Martin 1995: Fig. 3: 1, Fig. 4: 3; Sfredda, Tassinari 1998: T.

⁷ Dautova Ruševljan 1973; Konestra 2014. Također, zahvaljujemo kolegi M. Makarunu na uvidu u materijal s njegovih istraživanja na lokalitetu Kurilovo.

⁸ Nalaz nije objavljen u ranijim radovima, čuva se u Institutu za arheologiju.

The second group consists of specimens of refined fabric with black or grey slip (Fabrics D and E), without decoration or with stylized barbotine ornament (Schindler Kaudelka 1975: T. 10: 13–14). In this case too the specimens mostly belong to small bowls or cups (when the handle is present). Barbotine decoration appears on four specimens of bowl rims:

- N-101-1 (Pl. 8: 28): motif of connected twigs with a bud between two rows of dots (Sena Chiesa 1985: 403, Pl. 82: 15);

- N- 53-1 (Pl. 8: 29): a series of dots in at least two rows, within a framed area (we did not find a precise analogy);

- N-75-1 (Pl. 8: 30): irregular wide U-shaped barbotine ornaments (we did not find a precise analogy);

- N08-A5-30 (Pl. 8: 21): thin curved line, probably a part of a vegetable motif (shard is too small to reconstruct the motif).

The production of pottery of the second group began during Tiberius' reign and continued until the end of the 1st and the beginning of the 2nd cent.. It is precisely the vessels analogous to the second group that are present at the Kurilovo necropolis in Fulfinum (Dautova Ruševljan 1973; Konestra 2014). TWP of Italian origin is present also at a number of other sites in the Kvarner Gulf (Starac, R. 1991: 222–223; Ožanić Roguljić 2011: 32–33), although it is mostly unpublished. It is also known from the previous excavations at *Fulfinum* (Pavišić 1983: Pl. 1: 1–3, Pl. 2), however, the same pottery typologies are present along the eastern Adriatic coast, both within military camps and in civilian settlements (e.g. Tilurium, Burnum, Pula, Narona etc.) (Zabehlicky Scheffenegger 1979: 26–27; Matijašić 1991; Topić 2003: 190–191; Šimić-Kanaet 2010: 30–34).

Interestingly, the Forum site lacks the latter forms of TWP (2nd cent. AD), characterized by larger dimensions and new shapes (e.g. *ollette con collarino*), which appear at the Fulfinum necropolis of Kurilovo,⁷ although we might tentatively attribute N-131-5 (Pl. 8: 31), which lacks precise analogies, to the late phase of production of TWP.

Pannonische Glanztonware (PGW, Pl. 9, Tab. 11)

This type of fine tableware is present at the Forum of Fulfinum with only two specimens (N-55-1, N08-A2-1) (Pl. 9: 1–2), which belong to an identical form of semi-globular small bowl with thickened and inverted rim, even though their fabrics and slips are different. Pannonian grey or black ware is present mostly through the 2nd and 3rd cent., when it was produced in the territory of the province of Pannonia, with forms derived from the local tradition or imitating shapes of imported fine tableware. Although the shards from the forum do not have precise morphological analogies, we might group them with similar bowls from *Vindobona* and Padua (Chinelli et al. 2007: 26, Fig. 3/13), and they also bear a certain resemblance to f. 164 from Turopoljski lug, whose fabric, however, is completely different (Koščević, Makjanić 1986/87: 33, Pl. XVI: 164). A PGW shard

⁷ Dautova Ruševljan 1973; Konestra 2014. We thank also our colleague M. Makarun for the insight into the material from his excavations at Kurilovo.

Crtež	Br. n.	SJ	Oblik / Struktura	Datacija	Analogija
T. 9: 1	N-55-1	I.3010	Zdjelica / Boja: Gley 1 7/N; Primjese: sitne bijele; Premaz: mjestimice sačuvani sjajni premaz (GLEY 1 4/N); Ukras: vodoravna traka s više redova plitkih utisnutih zareza	2.–3. st.	Chinelli et al. 2007: 26, Fig. 3/13
T. 9: 2	N08-A2-1	I.2011	Zdjelica / Boja: GLEY 1, 6/5GY; Primjese: rijetke sitne bijele; Premaz: gotovo potpuno apsorbiran (GLEY 1 3/N); Ukras: vodoravna traka s više redova plitkih utisnutih zareza (ponavlja se više puta, vrlo plitko)	2.–3. st.	Chinelli et al. 2007: 26, Fig. 3/13
Drawing	No. f.	SU	Form / Fabric	Date	Analogy
Pl. 9: 1	N-55-1	I.3010	Small bowl / Colour: Gley 1 7/N; Inclusions: small white; Slip: occasionally preserved glossy slip (GLEY 1 4/N); Decoration: horizontal stripe with several rows of shallow impressed notches	2 nd -3 rd century	Chinelli et al. 2007: 26, Fig. 3/13
Pl. 9: 2	N08-A2-1	I.2011	Small bowl / Colour: GLEY 1, 6/5GY; Inclusions: rare small white; Slip: almost entirely absorbed (GLEY 1 3/N); Decoration: horizontal stripe with several rows of shallow impressed notches (repeats several times, very shallow)	2 nd -3 rd century	Chinelli et al. 2007: 26, Fig. 3/13

Tab. 11 Pannonische Glanztonware (PGW)

Tab. 11 Pannonische Glanztonware (PGW)

Crtež	Br. n.	SJ	Oblik / Struktura	Datacija	Analogija
T. 9: 3	N-98-22	I.2101	Rub / Boja: 5YR 8/3; Primjese: povremene srednje crne, povremene srednje crvene; Premaz: tamnozeleno glazura	Druga pol. 1. – 3. st.	Maccabruni 1976: 63–65, Fig. 5; Martin 1995: Fig. 3: 1, 4: 3; Sfreda, Tassinari 1998: T. XXV: 4
T. 9: 4	N-135-3	I.2123	Ručka / Boja: 5YR 6/4; Primjese: povremene srednje crvene; Rupice: rijetke; Premaz: tamnozeleno glazura	Druga pol. 1. – 3. st.	
Drawing	No. f.	SU	Form / Fabric	Date	Analogy
Pl. 9: 3	N-98-22	I.2101	Rim / Colour: 5YR 8/3; Inclusions: occasional medium black, occasional medium red; Slip: dark green glaze	Second half of 1 st – 3 rd century	Maccabruni 1976: 63–65, Fig. 5; Martin 1995: Fig. 3: 1, 4: 3; Sfreda, Tassinari 1998: Pl. XXV: 4
Pl. 9: 4	N-135-3	I.2123	Handle / Colour: 5YR 6/4; Inclusions: occasional medium red; Holes: rare; Slip: dark green glaze	Second half of 1 st – 3 rd century	

Tab. 12 Antička glazirana keramika

Tab. 12 Antique glazed pottery

XXV: 4), no zbog izrazito malih dimenzija teško je odrediti tip. Također vrlo malih dimenzija jest i drugi ulomak ove vrste, no on se odnosi na kaneliranu ručku (N-135-3, T. 9: 4), koja je česta na raznim oblicima glazirane keramike (npr. Sfreda, Tassinari 1998: T. XXV: 1). Početak proizvodnje ove keramičke vrste datira na kraj 1. i traje do 3. stoljeća, a osim istočnih radionica koje su s proizvodnjom započele nešto ranije, proizvodila se i u talijanskim radionicama, kako na sjeveru tako i u središnjoj Italiji, te u Panoniji, Meziji, Galiji, itd. (Martin 1992: 326; Brusić 1999: 33–34; Cvjetičanin 2001: 84). Na području Kvarnera antička glazirana keramika poznata je iz Osora, a javlja se i drugdje duž istočne obale Jadrana (Brusić 1999: 33; Topić 2003: 192–193; Šimić-Kanaet 2010: 35).

was found in the excavations carried out at Fulfinum in the 1970s,⁸ and there are also a number of specimens identified at other sites in the Kvarner Gulf, especially within the St. Mark's necropolis in Baška (Bekić, Višnjić 2008: 230–231, Pl. 14/16, 17, 19, Pl. 16/54–56, 58, 59, 61?, 62; Konestra 2013).

Antique glazed pottery (Pl. 9, Tab. 12)

To the category of antique glazed pottery we would attribute only two tiny shards. Rim shard N-98-22 (Pl. 9: 3) belongs to a small jug or cup (e.g. Maccabruni 1976: 63–65, Fig. 5; Martin 1995: Fig. 3: 1, Fig. 4: 3; Sfreda, Tassinari 1998: Pl. XXV: 4), but its exact type is difficult to ascertain due to its exceptionally small size. The other specimen of this ty-

⁸ The find was not published in the previous papers, it is kept at the Institute of Archaeology in Zagreb.

Kućanska keramika

Posude za pohranu i serviranje tekućina (T. 9, 10, tab. 13)

U kategoriju posuda za tekućine smještamo vrčeve, boce i amfore za kućnu upotrebu koje su korištene kao stolno posuđe ili za čuvanje namirnica. Vrčevima ili bocama, odnosno manjim amforama, zasigurno pripadaju ulomci ruba N-90-4 (T. 9: 5) i N-67-3 (T. 9: 6), koji bi prema strukturi i morfologiji mogli pripadati crikveničkoj proizvodnji (Tip V 5, Ožanić Roguljić 2012: 70; 2012a: Fig. 4), no vrlo se slični oblici javljaju i na području gornjeg Jadrana i sjeverne Italije (Akvileja, Sarsina, Milano, okolica Ferrare), ali i šire (Ostia,

pe is likewise very small: this is a fluted handle (N-135-3, Pl. 9: 4), which is common on various forms of glazed pottery (e.g. Sfredda, Tassinari 1998: Pl. XXV: 1). The beginning of production of this ceramic type is dated to the end of the 1st cent., continuing until the 3rd cent.. In addition to the eastern workshops, which started the production a bit earlier, it was produced also in Italian workshops, both in the north and in central Italy, as well as in Pannonia, Moesia, Gaul etc. (Martin 1992: 326; Brusić 1999: 33–34; Cvjetičanin 2001: 84). In the Kvarner Gulf, antique glazed pottery is known in Osor, but appears also elsewhere along the eastern Adriatic coast

Crtež	Br. n.	SJ	Oblik / Struktura	Datacija	Analogija
T. 9: 5	N-90-4	I.2101	Rub vrča/boce / Boja: 2.5yr 5/8; Primjese: povremene sitne bijele, crne i sjajne, rijetke velike bijele i crne	Druga pol. 1. st.	Ožanić Roguljić 2012: T. 38: 5; Chinelli, Tirone 1994: T. 38: CCD 52; Giovannini et al. 1998: T. 10/tomba 31: 4; Ortalli et al. 2008: 106, 108, 133, tomba 25: 14*
T. 9: 6	N-67-3	I.3010	Rub vrča/boce / Boja: 2.5yr 6/8, 5/8; Primjese: rijetke bijele srednje, povremene sitne sjajne	1. st.	Chinelli, Tirone 1994: T. 38: CCD 53; Chinelli, Tirone 1991: T. 36: CCD 16, T. 37: CCD 36–37
T. 9: 7	N08-A2-2	I.2011	Vrat vrča / Boja: 10YR 8/4; Primjese: česte sitne sjajne, rijetke sitne crvene		
/	N-124-3	I.2101	Rub vrča / Boja: 7.5YR 7/4; Primjese: česte sitne sive, povremene sitne sjajne		
T. 9: 8	N-98-18	I.2101	Rub / Boja: 2.5YR 5/8; Primjese: česte sitne bijele, crne, crvene, povremene srednje prozirne; po površini povremene velike prozirne		
T. 10: 1	N-1-8	I.3001	Vrat vrča / Boja: 5yr 6/8, 5/8, Primjese: česte sitne crne, česte sitne sjajne, povremene srednje bijele	1.–2. st.?	Ožanić Roguljić 2012: T. 15: 4
Drawing	No. f.	SU	Form / Fabric	Date	Analogy
Pl. 9: 5	N-90-4	I.2101	Jug/bottle rim / Colour: 2.5yr 5/8; Inclusions: occasional small white, black and glossy, rare large white and black	Second half of 1 st century	Ožanić Roguljić 2012: Pl. 38: 5; Chinelli, Tirone 1994: Pl. 38: CCD 52; Giovannini et al. 1998: Pl. 10/tomba 31: 4; Ortalli et al. 2008: 106, 108, 133, tomba 25: 14*
Pl. 9: 6	N-67-3	I.3010	Jug/bottle rim / Colour: 2.5yr 6/8, 5/8; Inclusions: rare white medium, occasional small glossy	1 st century	Chinelli, Tirone 1994: Pl. 38: CCD 53; Chinelli, Tirone 1991: Pl. 36: CCD 16, Pl. 37: CCD 36–37
Pl. 9: 7	N08-A2-2	I.2011	Jug neck / Colour: 10YR 8/4; Inclusions: frequent small glossy, rare small red		
/	N-124-3	I.2101	Jug rim / Colour: 7.5YR 7/4; Inclusions: frequent small grey, occasional small glossy		
Pl. 9: 8	N-98-18	I.2101	Rim / Colour: 2.5YR 5/8; Inclusions: frequent small white, black, red, occasional medium transparent; on the surface occasional large transparent		
Pl. 10: 1	N-1-8	I.3001	Jug rim / Colour: 5yr 6/8, 5/8, Inclusions: frequent small black, frequent small glossy, occasional medium white	1 st -2 nd century?	Ožanić Roguljić 2012: Pl. 15: 4

Tab. 13 Kućanska keramika, posude za pohranu i serviranje tekućina
Tab. 13 Domestic ware, pots for storing and serving liquids

*1 Ispravni broj vjerojatno 19.

*1 The correct number is probably 19.

Luni), i to u više varijanti, što bi upućivalo na njihovu lokalnu proizvodnju (Chinelli, Tirone 1991: 246, 256; Chinelli, Tirone 1994: 255–256; Ortalli et al. 2008: 131–132). Okvirne datacije kreću se unutar 1. st. pos. Kr., no ponekad se protežu sve do 4. stoljeća. Rubu vrča s trolisnim izljevom pripada mali ulomak ruba N-124-3⁹ vrlo svijetle strukture, kojeg nije moguće pobliže tipološki definirati, no sigurno pripada ranocarskom kronološkom horizontu. Vratu vrča pripada ulomak N-08-A2-2 (T. 9: 7), dok je za rub N-98-18 (T. 9: 8) upitna atribucija i to zbog grublje strukture.

Više ulomaka kaneliranih ručaka valjalo bi također pripisati vrčevima ili loncima za kućansku upotrebu, no u pojedinim slučajevima oni bi mogli pripadati i manjim amforama, a prema ulomcima nije moguće preciznije definirati oblik, dok je za neke moguće pretpostaviti pripadnost crikveničkim posudama.

Većem vrču ili amfori pripada vrat N-1-8 (T. 10: 1) s ukrasom u obliku dvaju urezanih paralelnih linija, izrađen od pročišćene strukture s premazanom površinom, a mogao bi također pripadati crikveničkoj proizvodnji (Ožanić Roguljić 2012: T. 15: 4).

Lonci (T. 10, tab. 14)

Lonac N08-A6-3 (T. 10: 2, 3) smještamo u kategoriju kućanske keramike zbog njegove pročišćene strukture i doista tankih stijenki, što ga čini neprikladnim za korištenje na vatri, dok možemo pretpostaviti funkciju čuvanja namirnica (posebice zbog postojanja utora za poklopac). Posuda je sačuvana u više ulomaka ruba, stijenki i dna, a na svima je prisutan crveni premaz. Slične su se posude proizvodile u crikveničkoj radionici, a crveni premaz također ide u prilog identifikaciji ove posude kao crikveničkog proizvoda (Tip L1, Ožanić Roguljić 2012: 84). Više primjeraka slične posude s jednako tankim stijenkama pronađeno je u Trstu – lokalitet Crosada, no sa širokom datacijom od kraja 1. st. pr. Kr. do početka 5. st. pos. Kr. (Tipo 9, Riccobono 2007: 109–110). U Akvileji slična posuda finije izvedbe (CCg 34) datirana je prema stratigrafiji u prvu polovinu 1. st. pos. Kr. (Rupel 1994: 214), a posude tanjih stijenki ali s ukrasom na ramenu javljaju se i u Puli, gdje su datirane od kraja 1. st. pr. Kr. do 2. st. pos. Kr. (Starac, A. 2006: 59, T. XIX: 302).

Česte su slične posude grublje strukture i većih dimenzija, ponekad s ukrasom na ramenu, pa su tako oblikovani lonci korišteni kao urne u paljevinskim grobovima pulske nekropole *Campus martius* (Matijašić 1991: T. 1: g. 4/1, T. 7: g. 12/1) i akvilejskoj nekropoli Beligna (Giovannini et al. 1998: 253–254, T. 8: tomba 27), a posude slične morfologije prisutne su i u Akvileji istočno od Foruma (Rupel 1994: 214, CCg 37), gdje su prema analogijama datirane u 1. do 2. st. pos. Kr. Kuhinjska funkcija ovakvih lonaca potvrđena je u Naroni (Topić 2004: 340, br. 112–115).

Ulomak ruba i ručke N-131-32 (T. 10: 4) vrlo tankih stijenki pripada posudi koja je služila za pohranu namirnica (Guglielmetti et al. 1991: 152–153), a vjerojatno je imala dvije ručke. Ovaj se tip posuda proizvodio i u Crikvenici, a fulfinski primjerak blizak je crikveničkom tipu VŠ 3 (Ožanić Roguljić 2012: 75). Slične su posude, definirane kao lonci, česte

(Brusić 1999: 33; Topić 2003: 192–193; Šimić-Kanaet 2010: 35).

Domestic ware

Vessels for storing and serving liquids (Pl. 9, 10, Tab. 13)

In the category of liquid-storage vessels we include jugs, bottles and amphorae for domestic use, which were used as tableware or for storing foodstuffs. To jugs or bottles, or smaller amphorae, we can certainly attribute rim shards N-90-4 (Pl. 9: 5) and N-67-3 (Pl. 9: 6), whose fabric and morphology might point to the Crikvenica production (Type V 5, Ožanić Roguljić 2012: 70; 2012a: Fig. 4), although very similar shapes appear also in the Upper Adriatic and northern Italy (Aquileia, Sarsina, Milan, surroundings of Ferrara), but also over a wider area (Ostia, Luni), in several variants, which would suggest that they were produced locally (Chinelli, Tirone 1991: 246, 256; Chinelli, Tirone 1994: 255–256; Ortalli et al. 2008: 131–132). Approximate dates fall within the 1st cent. AD, however, may sometimes continue until as late as the 4th cent. Jug with trefoil spout is represented with rim shard N-124-3⁹, of very bright fabric, which is difficult to define typologically with any greater accuracy, although it certainly belongs to the early imperial chronological horizon. Shard N-08-A2-2 (Pl. 9: 7) belongs to the neck of a jug, while the attribution of rim N-98-18 (Pl. 9: 8) is doubtful due to its coarse fabric.

A number of shards of fluted handles also ought to be attributed to jugs or jars for domestic use, although in certain cases these might belong to small amphorae. The shape cannot be defined with precision based on shards, while for some we might presume that they belonged to Crikvenica pottery.

Neck N-1-8 (Pl. 10: 1) belongs to a large jug or amphora. It is decorated with two incised parallel lines. It was made of levigated fabric with slipped surface. This shard might also belong to the Crikvenica production (Ožanić Roguljić 2012: Pl. 15: 4).

Jars (Pl. 10, Tab. 14)

Jar N08-A6-3 (Pl. 10: 2, 3) is attributed to the domestic ware category on account of its levigated fabric and fairly thin walls, which makes it unsuitable for use on fire, but still appropriate for storing foodstuffs (especially because it has a groove for a lid). The vessel is preserved with a number of rim, wall and base shards, all of which have a red slip. Similar vessels were made in the Crikvenica workshop, and the red slip also speaks in favour of the identification of this vessel as a product from Crikvenica (Type L1, Ožanić Roguljić 2012: 84). Several specimens of a similar vessel with equally thin walls were found in Trieste – at the Crosada site, which, however, was dated widely from the end of the 1st cent. BC until the beginning of the 5th cent. AD (Tipo 9, Riccobono 2007: 109–110). In Aquileia, a similar vessel, but of finer workmanship (CCg 34) was dated based on the stratigraphy to the first half of the 1st cent. AD (Rupel 1994: 214). Thin-walled vessels decorated on the shoulder appear also in Pula, where they are dated from the end of the 1st cent. BC until the 2nd cent. AD (Starac, A. 2006: 59, Pl. XIX: 302).

9 Ovaj predmet nije bilo moguće nacrtati zbog malih dimenzija.

9 It was impossible to draw this object due to its small size.

Crtež	Br. n.	SJ	Oblik / Struktura	Datacija	Analogija
T. 10: 2, 3	N-08-A6-3	Površinski nalaz uz južni zid	Rub i dno lonca / Boja: 2.5yr 5/8; Primjese: česte sitne bijele, povremene sitne crne; Premaz: crveni	1.–2. st.	Ožanić Roguljić 2012: T. 67: 4, 5; Riccobono 2007: T. 25: 17; Rupel 1994: T. 29: CCg 34
T. 10: 4	N-131-32	I.4000	Rub i ručka lonca / Boja: 7.5YR 5/6; Primjese: povremene sitne bijele	Druga pol. 1. st. pr. Kr. – sredina 1. st. po. Kr.	Ožanić Roguljić 2012: T. 56: 3; Riccobono 2007: T. 20: 26, 27; Tirone 1994: T. 40: CCd 78; Guglielmetti, Lecca Bishop, Ragazzi 1991: T. LXII: 1–4
Drawing	No. f.	SU	Form / Fabric	Date	Analogy
Pl. 10: 2, 3	N-08-A6-3	Surface find next to the southern wall	Rim and base of a jar/ Colour: 2.5yr 5/8; Inclusions: frequent small white, occasional small black; Slip: red	1 st -2 nd century	Ožanić Roguljić 2012: Pl. 67: 4, 5; Riccobono 2007: Pl. 25: 17; Rupel 1994: Pl. 29: CCg 34
Pl. 10: 4	N-131-32	I.4000	Rim and handle of a jar / Colour: 7.5YR 5/6; Inclusions: occasional small white	Second half of 1 st century BC – mid-1 st century AD	Ožanić Roguljić 2012: Pl. 56: 3; Riccobono 2007: Pl. 20: 26, 27; Tirone 1994: Pl. 40: CCd 78; Guglielmetti, Lecca Bishop, Ragazzi 1991: Pl. LXII: 1–4

Tab. 14 Kućanska keramika, lonci

Tab. 14 Domestic ware, jars

na području sjeverne Italije (Trst, Akvileja, Milano, Brescia) gdje datiraju od kraja 1. st. pr. Kr. do sredine 1. st. pos. Kr. (Riccobono 2007: 99, n. 23–24, Tirone 1994: 256, CCd 78; Guglielmetti et al. 1991: 152–153).

Zdjela (T. 10, tab. 15)

Ulomak profiliranog ruba i ručke (N-90-5, T. 10: 5) izrazito pročišćene žučkaste strukture ne nalazi preciznije analogije, iako bismo ga morfološki smjestili unutar kategorije zdjela s dvije ručke kakve se javljaju na Magdalensbergu kao import (2. i 3. faza, prva polovina 1. stoljeća) (Schindler Kaudelka 2012: 224, Fig. 22: 14, Fig. 24: 5).

Poklopci (T. 10, tab. 16)

Među kućansku keramiku smještamo i ulomak poklopca N08-A4-2 (T. 10: 6) koji zbog svoje strukture djeluje neprikladno za korištenje u kuhinji, a čije bi dimenzije mogle upućivati na korištenje uz veću posudu za pohranu namirnica.

One often encounters similar vessels, although of coarser fabric and larger size, sometimes decorated on the shoulder, used as urns in cremation graves at the *Campus martius* necropolis in Pula (Matijašić 1991: Pl. 1: g. 4/1, Pl. 7: g. 12/1) and the Beligna necropolis in Aquileia (Giovannini et al. 1998: 253–254, Pl. 8: tomba 27). Vessels with a similar morphology appear also in Aquileia east of the Forum (Rupel 1994: 214, CCg 37), where they are dated, based on analogies, to the 1st to 2nd cenPl. AD. The cooking-function of such jars was confirmed in Narona (Topić 2004: 340, no. 112–115).

Rim and handle shard N-131-32 (Pl. 10: 4), of very thin walls, belongs to a food-storage vessel (Guglielmetti et al. 1991: 152–153), which probably had two handles. This type of pottery was produced in Crikvenica, and the specimen from Fulfinum is similar to the Crikvenica type JW 3 (Ožanić Roguljić 2012: 75). Similar vessels, defined as jars, are common in northern Italy (Trieste, Aquileia, Milan, Brescia), where they are dated from the end of the 1st cenPl. BC until

Crtež	Br. n.	SJ	Oblik / Struktura	Datacija	Analogija
T. 10: 5	N-90-5	I.2101	Rub zdjele / Boja: 5Y 6/2 – goreno, 10yr 8/4; Primjese: povremene sitne crne i crvene	Prva pol. 1. st.	Schindler Kaudelka 2012: Fig. 22/14, 24/5
Drawing	No. f.	SU	Form / Fabric	Date	Analogy
Pl. 10: 5	N-90-5	I.2101	Bowl rim / Colour: 5Y 6/2 – burnt, 10yr 8/4; Inclusions: occasional small black and red	First half of 1 st century	Schindler Kaudelka 2012: Fig. 22/14, 24/5

Tab. 15 Kućanska keramika, zdjele

Tab. 15 Domestic ware, bowls

Crtež	Br. n.	SJ	Oblik / Struktura	Datacija	Analogija
T. 10: 6	N08-A4-2	I.2001	Rub poklopca / Boja: 2.5YR 5/8; Primjese: česte sitne i srednje bijele		
Drawing	No. f.	SU	Form / Fabric	Date	Analogy
Pl. 10: 6	N08-A4-2	I.2001	Lid rim / Colour: 2.5YR 5/8; Inclusions: frequent small and medium white		

Tab. 16 Kućanska keramika, poklopci

Tab. 16 Domestic ware, lids

Kuhinjska keramika

Kuhinjskom keramikom smatramo keramiku grube strukture namijenjenu korištenju na vatri, odnosno namijenjenu kuhanju. Riječ je o loncima, tavama i poklopcima na kojima su često vidljivi tragovi gorenja, a sama njihova izrada, koja često podrazumijeva namjerno dodavanje primjesa, govori o njihovoj kuhinjskoj namjeni. Iznimkom možemo smatrati kuhinjsku keramiku afričke provenijencije čija je struktura pročišćenija, iako joj je namjena istovjetna.

Analizom keramičkih nalaza s foruma *Fulfinuma* ustanovljena su 92 ulomka grube strukture koje smještamo u kategoriju kuhinjske keramike. Datacija fulfinske grube keramike proteže se od antike do kasne antike/ranoga srednjeg vijeka. Datiranje grube keramike prema analogijama u ovom je slučaju dosta otežano zbog nepostojanja sustavnih objava ove keramičke vrste s područja Kvarnera, a kako ovo posuđe, zbog svojih funkcionalnih karakteristika, zadržava slična morfološka obilježja kroz dulja razdoblja ali pokazuje i određene regionalne značajke, problem nepostojanja objava dobro datiranih cjelina posebno je izražen. Zbog navedene problematike analogije su identificirane na širem području gornjeg i srednjeg Jadrana te neposrednoj unutrašnjosti (Italija, Slovenija, Istra).

Osnovna podjela kuhinjskog posuđa provedena je na osnovi struktura: ustanovljeno je 19 struktura koje su prikazane u tab. 26. Zatim su ulomci podijeljeni prema pripadnosti morfološkim oblicima i na kraju, što se tiče ulomaka stijenki, prema ukrasu. Osnovna strukturalna podjela pomogla je i u identificiranju ranoantičkih i kasnoantičkih struktura, što je uz analizu dijagnostičkih ulomaka pomoglo u dataciji pojedinih primjeraka.

Morfološkom smo podjelom identificirali pojedine oblike: lonce, tave/zdjele i poklopce. Posebno je izdvojena afrička kuhinjska keramika (graf. 3). Osim u slučaju potonje, tek smo u nekoliko slučajeva u mogućnosti razlikovati uvozno

the mid-1st cent. AD (Riccobono 2007: 99, n. 23–24, Tirone 1994: 256, CCd 78; Guglielmetti et al. 1991: 152–153).

Bowls (Pl. 10, Tab. 15)

A shard with a profiled rim and handle (N-90-5, Pl. 10: 5), of extremely levigated yellowish fabric, does not have precise analogies, although we might attribute it, on account of its morphology, to the category of two-handled bowls like those known from Magdalensberg as imports (2nd and 3rd phases, first half of the 1st cent.) (Schindler Kaudelka 2012: 224, Fig. 22: 14, Fig. 24: 5).

Lids (Pl. 10, Tab. 16)

Lid shard N08-A4-2 (Pl. 10: 6) is also attributed to domestic ware. Its fabric makes it improbable that it was used in the kitchen, and its size might suggest that it was used with a larger food-storage vessel.

Cooking ware

The term cooking ware refers to coarse-fabric pottery used on fire, that is, for cooking. It comprises jars, pans and lids, which often exhibit traces of firing, and their very workmanship, which often entails intentional addition of inclusions, speaks of their function in the kitchen. A possible exception is the cooking ware of African origin, which features a better levigated fabric, if serving the identical purpose.

The analysis of ceramic finds from the forum of *Fulfinum* resulted in 92 coarse-fabric shards attributable to the cooking ware category. Dating of coarse pottery from Fulfinum stretches from antiquity to late antiquity/Early Middle Ages. Dating of coarse pottery by analogies is rendered fairly difficult in this case due to the lack of systematic publications of this ceramic type from the Kvarner Gulf. Since this ware, due to its functional traits, had preserved similar morphological features over longer periods, although also exhibiting

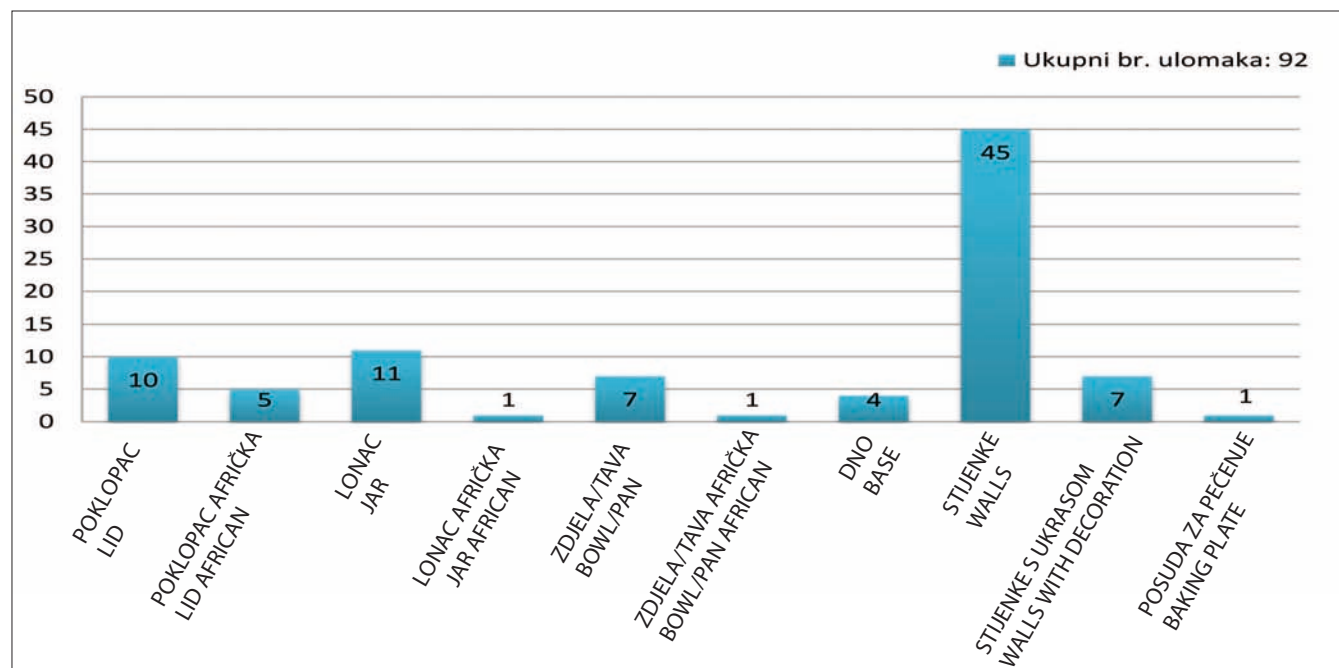

Graf. 3 Kuhinjsko posuđe: pripadnost oblicima

Graph 3 Cooking ware: attribution to forms

Crtež	Br. n.	SJ	Oblik / Struktura / Ukras	Datacija	Analogija
T. 11: 1	N - 131 - 33	I.4000	Lonac / STR. 17	Kraj 1. st. – početak 2. st.	Ožanić Roguljić 2012: 65/1; Saccardo 1985: T. 93: 6
T. 11: 2	N-131-36	I.4000	Lonac / STR. 17	1.–2. st.	Ožanić Roguljić 2012: T. 65: 3
T. 11: 3	N-131-37	I.4000	Lonac / STR. 17	Kraj 1. st. – početak 2. st.	Ožanić Roguljić 2012: T. 65: 3
T. 11: 4	N08-A5-31	I.2002	Lonac / STR. 17	1.–2. st.	
T. 12: 1	N08-A1-5	I.2003	Rub lonca / STR. 7	Kraj 1. st. – 3. st. (?)	Bloier 2012: T. 19: 1810
T. 12: 2	N-80-1	I.3012	Rub lonca / STR. 5	Najranije 3. st. – kasna antika	Rupel 1991: T. 20: CCg 1
T. 12: 3	N-16-10	I.3002	Rub lonca / STR. 2	4.–7. st.	Cavalazzi, Fabbri 2010: 624, olle type 9, Fig. 4: 11; Rupel 1994: 202, 211–212 CCg 24–27 – Luni gruppo T38; Bloier 2012: T. 20: 1895
T. 12: 4	N-16-8 + N-23-1	I.3002	Rub lonca / STR. 16	Druga pol. 4. – početak 5. st.	Mondrijan 2011: T. 97/7
T. 12: 5	N-55-2	I.3010	Rub lonca / STR. 5 / Ukas tip 3	Prva pol. 5. st. – prva pol. 7. st.	Bierbrauer 1987: T. 120/1 (oblik III d2); Negri 1994: T. 5: 1–4
T. 12: 6	N08-A5-25	I.2002	Rub lonca / STR. 7	Prva pol. 5. st. – prva pol. 7. st.	Bierbrauer 1987: T. 90/19, 119/10, 120/13 (oblik III C2)
Drawing	No. f.	SU	Form / Fabric / Decoration	Date	Analogy
Pl. 11: 1	N - 131 - 33	I.4000	Pot / FAB. 17	End of 1 st – beginning of 2 nd century	Ožanić Roguljić 2012: 65/1; Saccardo 1985: Pl. 93: 6
Pl. 11: 2	N-131-36	I.4000	Pot / FAB. 17	1 st -2 nd century	Ožanić Roguljić 2012: Pl. 65: 3
Pl. 11: 3	N-131-37	I.4000	Pot / FAB. 17	End of 1 st – beginning of 2 nd century	Ožanić Roguljić 2012: Pl. 65: 3
Pl. 11: 4	N08-A5-31	I.2002	Pot / FAB. 17	1 st -2 nd century	
Pl. 12: 1	N08-A1-5	I.2003	Pot rim / FAB. 7	End of 1 st – 3 rd century (?)	Bloier 2012: Pl. 19: 1810
Pl. 12: 2	N-80-1	I.3012	Pot rim / FAB. 5	Earliest 3 rd century – late antiquity	Rupel 1991: Pl. 20: CCg 1
Pl. 12: 3	N-16-10	I.3002	Pot rim / FAB. 2	4 th -7 th century	Cavalazzi, Fabbri 2010: 624, olle type 9, Fig. 4: 11; Rupel 1994: 202, 211–212 CCg 24–27 – Luni gruppo T38; Bloier 2012: Pl. 20: 1895
Pl. 12: 4	N-16-8 + N-23-1	I.3002	Pot rim / FAB. 16	Second half of 4 th century – beginning of 5 th century	Mondrijan 2011: Pl. 97/7
Pl. 12: 5	N-55-2	I.3010	Pot rim / FAB. 5 / Decoration type 3	First half of 5 th century – first half of 7 th century	Bierbrauer 1987: Pl. 120/1 (form III d2); Negri 1994: Pl. 5: 1–4
Pl. 12: 6	N08-A5-25	I.2002	Pot rim / FAB. 7	First half of 5 th century – first half of 7 th century	Bierbrauer 1987: Pl. 90/19, 119/10, 120/13 (form III C2)

Tab. 17 Kuhinjska keramika, lonci

Tab. 17 Cooking ware, jars

posuđe od onog proizvedenog lokalno, i to poglavito jer nedostaju nalazi proizvodnih centara grubog posuđa na području Kvarnera, posebice onih koje bismo datirali u kasnoantičko razdoblje.¹⁰

Lonci (T. 11, 12, tab. 17)

U prvu kronološku kategoriju lonaca, onu ranocarske datacije, smještamo četiri lonca koji pripadaju strukturama 16 i

¹⁰Crikvenička radionica kao jedino proizvodno središte rimskodobne keramike na širem priobalnom području antičke Liburnije proizvodila je i keramiku grublje strukture.

certain regional characteristics, the problem of the lack of publications of well-dated contexts comes particularly to the fore. Due to this, analogies were identified in the wider area of the Upper and Central Adriatic and the immediate hinterland (Italy, Slovenia, Istria).

The basic division of cooking ware was carried out based on the fabrics: a total of 19 fabrics were determined, shown in Tab. 26. Shards were then divided by affiliation to morphological forms, and lastly, when wall shards are concerned, based on decorations. The basic division by fabrics helped also in the identification of early antique and late antique fa-

17 (tab. 26). N-131-36 i N-131-37 (T. 11: 2–3) nalaze analogije u crikveničkoj proizvodnji (Tip L 2a, Ožanić Roguljić 2012: 84, sl. 43), iako su arheometrijske analize još uvijek u tijeku. N-131-33 (T. 11: 1) nalazi analogiju u Angeri gdje se javlja u dvjema dimenzijama s datacijom u vrijeme Flavijevaca (Saccardo 1985: 471), iako je s obzirom na strukturu blizak i tipu L2a (Ožanić Roguljić 2012: 84, sl. 43) crikveničke keramike. N08-A5-31 (T. 11: 4) ne nalazi precizne analogije u dosad analiziranim tipovima crikveničke keramike, no prema strukturi joj je dosta blizak, pa je stoga pretpostavljena slična datacija. U drugu kategoriju lonaca smještamo lonce pečene u redukcijskoj atmosferi čija je struktura vrlo gruba, karakterizirana čestim primjesama kvarca i kalcita (STR. 1–15, tab. 26), a čija je datacija mahom kasnoantička. Iako su posude uglavnom tamnih boja, one i na pojedinoj posudi mogu varirati od sive do smeđe, a ponekad i narančaste. Načini tretiranja površine uključuju zaglađivanje, premazivanje (*ingobbatura*) te ukrašavanje (tab. 27) koje se javlja kako na vanjskoj tako i na unutarnjoj površini.

Lonci kasnije datacije također nalaze analogije na prostoru gornjeg Jadrana (Istra, Friuli-Venezia Giulia) te sjeverne Italije i Slovenije, dok preciznije analogije s materijalom s kasnoantičkih lokaliteta Kvarnera nedostaju, iako su primijećene analogije s ukrasima (T. 11, tab. 27). Najraniju dataciju ima lonac N08-A1-5 (T. 12: 1) koji nalazi analogije na Brijunima, gdje je "pod upitnikom" datiran od kraja 1. do 3. stoljeća (Bloier 2012: 312, cat. 1810). Slijedi lonac N-80-1 (T. 12: 2) s analogijama u Akvileji čija je najranija datacija 3. stoljeće, no nastavlja kroz kasnu antiku (Rupel 1991: 147, 149). Između 4. i 7. stoljeća datirani su ostali lonci, a posebno je zanimljiv zbog brojnih analogija N-16-10 (T. 12: 3, za analogije vidi tab. 16), no njegova je datacija i najšira. Iako najbolje sačuvani primjerak lonca N-16-8+N-23-1 (T. 12: 4), tipološki je rijedak i nalazi analogiju samo na Toncovu gradu u Sloveniji, no s preciznom datacijom od druge polovine 4. do početka 5. stoljeća (Modrijan 2011: 196). Lonac N08-A5-25 (T. 12: 6) nalazi analogije u Invillinu s datacijom od prve polovine 5. do prve polovine 7. stoljeća (Bierbrauer 1987: 196–197, tip IIIc2), dok se posude sličnog oblika i istovjetnog ukrasa kao N-55-2 (T. 12: 5) javljaju u Invillinu i Osoppu, s istovjetnom datacijom (Bierbrauer 1987: 197–198; Negri 1994: 70). Morfološka i dekorativna sličnost registrirana je i s grupom posuda s Tilurija, gdje su interpretirane kao lokalna proizvodnja, a uglavnom se nalaze u kontekstu s mlađim nalazima (Šimić-Kanaet 2010: 37, T. 138–141: 1566, 1565).

Tave/zdjela (T. 13, tab. 18)

U kategoriju tava/zdjela smještamo sve ulomke koji pripadaju posudama šireg oboda i vjerojatno niskih stijenki te ravnog dna, a smještaju se u kategoriju grube keramike, pa je stoga i za njih pretpostavljena kuhinjska funkcija.

Unutar ove kategorije posebno se izdvaja ulomak ruba tave sa žlijebom za poklopac N-08-A5-24 (T. 13: 1), tzv. *tagama ad orlo bifido*. Moguće je i da ulomak dna N-117-30 (T. 13: 2) s reljefnim žlijebom također pripada ovom tipu (ako ne i istoj posudi). S obzirom na strukturu (STR. 12, tab. 26) unutar koje su prisutne crne primjese vulkanskog podrijetla te zlat-

brics, which, together with the analysis of diagnostic shards, aided in the dating of individual specimens.

The morphological division identified distinct shapes: jars, pans/bowls and lids. African cooking ware was shown separately (graph 3). Except in the case of the latter ware, we were able to distinguish between imported and locally-made pottery only in a few cases, mostly because we are lacking in the knowledge about production centres of coarse pottery in the Kvarner Gulf, especially those might be dated into late antiquity.¹⁰

Jars (Pl. 11, 12, Tab. 17).

In the first chronological category of jars, those of early imperial date, we include four jars that belong to fabrics 16 and 17 (Tab. 26). N-131-36 and N-131-37 (Pl. 11: 2–3) have analogies among the Crikvenica finds (Type L 2a, Ožanić Roguljić 2012: 84, Fig. 43), although archaeometric analyses are still in progress. N-131-33 (Pl. 11: 1) has an analogy in Angera, where it appears in two sizes, dated to the time of the Flavian dynasty (Saccardo 1985: 471), even though taking into consideration its fabric it is also similar to type 2a (Ožanić Roguljić 2012: 84, Fig. 43) of the Crikvenica pottery. N08-A5-31 (Pl. 11: 4) has no precise analogies in the so far analysed types of Crikvenica pottery, however, the two fabrics are fairly close, due to which a similar date is presumed.

The second category consists of jars fired in the reduction atmosphere, with a very coarse fabric frequently featuring quartz and calcite inclusions (FAB. 1–15, Tab. 26), by and large dating from late antiquity. Even though the pots are generally of dark colours, these may vary from grey to brown, sometimes orange, even on a single vessel. Surface treatment methods include smoothing, engobing (*ingobbatura*) and decoration (Tab. 27) of exterior and interior walls.

Jars dated to a later phase likewise have analogies in the Upper Adriatic region (Istria, Friuli-Venezia Giulia) and Northern Italy and Slovenia, while detailed analogies with the material from late antique sites in the Kvarner Gulf are lacking, even though certain analogies were noted in decorations (Pl. 11, Tab. 27). The earliest dated jar is N08-A1-5 (Pl. 12: 1), with analogies on the Brijuni Islands, which was tentatively dated from the end of the 1st cent. AD until the 3rd cent. (Bloier 2012: 312, cat. 1810). The next jar is N-80-1 (Pl. 12: 2), with analogies in Aquileia, with earliest possible dating in the 3rd cent. and continuing through late antiquity (Rupel 1991: 147, 149). Among other jars, which are dated between the 4th and 7th cent., we single out N-16-10 (Pl. 12: 3, for analogies see T. 16) on account of numerous analogies, however, its date range is also the widest of all. The best preserved jar specimen, N-16-8+N-23-1 (Pl. 12: 4), is typologically rare, with a single analogy at Toncov grad in Slovenia. It can be precisely dated from the second half of the 4th cent. until the beginning of the 5th cent. (Modrijan 2011: 196). Jar N08-A5-25 (Pl. 12: 6) has analogies in Invillino, with

¹⁰ The Crikvenica workshop, as the only production centre of Roman-period pottery in the wider coastal area of ancient Liburnia, produced also coarse ware.

Crtež	Br. n.	SJ	Oblik / Struktura / Ukraš	Datacija	Analogija
T. 13: 1	N08-A5-24	I.2002	Rub tave / STR. 12	Kraj 1. st. pr. Kr. – 2. st. po. Kr.	Di Giovanni 1996: tip 2130, Fig. 9; Topić 2004: T. 21: 80–81; Zabe-hlicky Scheffenegger 1979: T. 13: 2; Borzić 2014: T. 2: 7
T. 13: 2	N-117-30	Površinski nalaz u I.2	Dno tave? / STR. 12	Kraj 1. st. pr. Kr. – 2. st. po. Kr.	Topić 2004: T. 20: 79, 21: 80–81
T. 13: 3	N-101-9	I.2101	Rub tave / STR. 6	Pol. 4. st. – prva pol. 7. st.	Bierbrauer 1987: T. 103/1 (oblik R la). Datacija, u II i III period, češće III
T. 13: 4	N-67-2	I.3010	Rub tave / STR. 7/ Ukraš tip 2	Prva pol. 5. st. – prva pol. 7. st.	Bierbrauer 1987: T. 71, Id; Višnjić et al. 2010: T. 7: 8, 10
T. 13: 5	N-55-3	I.3010	Rub tave / STR. 1 / Ukraš tip 1	Prva pol. 5. st. – prva pol. 7. st.	Bierbrauer 1987: T. 71, oblik Id; Invillino I, 108/1, 115/7, 116/4
T. 13: 6	N-14-1	I.3006	Rub tave / STR. 2 / Ukraš tip 4	5. st. – prva pol. 6. st.	Ruffieux 2010: pl. 5/GSC.08.25-11; Bierbrauer 1987: T. 71: 3, 100: 10; Boltin-Tome 1989/90: T. 1: 1
T. 13: 7	N-5-9	I.3002	Rub tave / STR. 3	Pol. 4. st. – prva pol. 7. st.	Negri 1994: T. 2: 5
T. 13: 8	N-117-17	Površinski nalaz u I.2	Rub/dno pladnja – pekača / STR. 7	5.–6. st.	Marušić 1986: T. 11: 1; Višnjić et al. 2010: T. 6: 9; Lavazza, Vitali 1994: tav. 9: 11
Drawing	No. f.	SU	Form / Fabric / Decoration	Date	Analogy
Pl. 13: 1	N08-A5-24	I.2002	Pan rim / FAB. 12	End of 1 st century BC – 2 nd century AD	Di Giovanni 1996: tip 2130, Fig. 9; Topić 2004: Pl. 21: 80–81; Zabe-hlicky Scheffenegger 1979: Pl. 13: 2; Borzić 2014: Pl. 2: 7
Pl. 13: 2	N-117-30	Surface find in I.2	Pan base? / FAB. 12	End of 1 st century BC – 2 nd century AD	Topić 2004: Pl. 20: 79, 21: 80–81
Pl. 13: 3	N-101-9	I.2101	Pan rim / FAB. 6	Mid-4 th century – first half of 7 th century	Bierbrauer 1987: Pl. 103/1 (form R la). Date, in II and III period, more frequently III
Pl. 13: 4	N-67-2	I.3010	Pan rim / FAB. 7/ Decorati-on type 2	First half of 5 th century – first half of 7 th century	Bierbrauer 1987: Pl. 71, Id; Višnjić et al. 2010: T. 7: 8, 10
Pl. 13: 5	N-55-3	I.3010	Pan rim / FAB. 1 / Decorati-on type 1	First half of 5 th century – first half of 7 th century	Bierbrauer 1987: Pl. 71, form Id; Invillino I, 108/1, 115/7, 116/4
Pl. 13: 6	N-14-1	I.3006	Pan rim / FAB. 2 / Decorati-on type 4	5 th century – first half of 6 th century	Ruffieux 2010: pl. 5/GSC.08.25-11; Bierbrauer 1987: Pl. 71: 3, 100: 10; Boltin-Tome 1989/90: Pl. 1: 1
Pl. 13: 7	N-5-9	I.3002	Pan rim / FAB. 3	Mid-4 th century – first half of 7 th century	Negri 1994: Pl. 2: 5
Pl. 13: 8	N-117-17	Surface find in I.2	Baking plate rim/base / FAB. 7	5 th -6 th century	Marušić 1986: Pl. 11: 1; Višnjić et al. 2010: Pl. 6: 9; Lavazza, Vitali 1994: tav. 9: 11

Tab. 18 Kuhinjska keramika, tave

Tab. 18 Cooking ware, pans

ni tinjac, možemo zaključiti kako je riječ o proizvodu kam-panskih radionica od 1. st. pr. Kr. do 1. st. pos. Kr., a ne afričke varijante istog oblika (Riley 1979: 247–250; Di Giovanni 1996: 78, tip 2130; Topić 2004: 306). Uz tavu N-08-A5-24 povezu-jemo poklopce iste keramičke strukture koji su na Fulfinu-mu prisutni u tri varijante.¹¹ Ove su posude, zajedno s pri-padajućim poklopcima, česte na istočnom Jadranu, npr. u Naroni (Topić 2004: 306), Burnumu – forum i amfiteatar (Za-behlicky Scheffenegger 1979: 32; Borzić 2014: 291), Tiluriju (Šimić Kanaet 2010: 39, T. 281–282), Zadru (Glušćević 1990: 131, T. XVIII/1), no najznačajniji je nalaz ovih posuda onaj na podvodnom lokalitetu rt Glavat kod Mljeta, gdje čine 97,3% tereta, a pronađene su “pakirane” zajedno s poklopcima/ta-

dates from the first half of the 5th c. until the first half of the 7th cent. (Bierbrauer 1987: 196–197, type IIIc2), while similarly shaped vessels with identical decoration as N-55-2 (Pl. 12: 5) appear in Invillino and Osopp, and they are also dated the same (Bierbrauer 1987: 197–198; Negri 1994: 70). Morp-hological and decorative resemblance was also registered with an assemblage of pots from Tilurium, where they were attributed to the local production, and which were mainly found in the context with younger finds (Šimić-Kanaet 2010: 37, Pl. 138–141: 1566, 1565).

Pans/bowls (Pl. 13, Tab. 18)

We included in this category all shards belonging to pots with wide rims and probably low walls and flat base, which fall in the category of coarse pottery, due to which

¹¹ Detaljnije u poglavlju o poklopcima.

njurima (Jurišić 2000: 29–30). U podmorju istočnog Jadrana ove su posude pronađene i na brodolomu Gušteranski kod Žirja, gdje su putovale zajedno s Forlimpopoli amforama, te uz Galijulu u Palagruškom arhipelagu (Jurišić 2000: 30). S kvarnerskog područja poznat je jedan ulomak “pompejskoga tanjura” koji potječe iz podmorja Ilovika (Jurišić 2000: 30). *Tegami ad orlo bifido* jedini su proizvodi južnotirenske obale italskog poluotoka dosad registrirani u *Fulfinumu* (a vjerojatno i na širem kvarnerskom području), gdje dolaze samostalno, odnosno bez popratnih lonaca tipičnih za kampanjski kuhinjski servis (lonac sa zakošenim rubom i lonac s ravnim izvučenim rubom) (Di Giovanni, Soricelli 2013: 185).

Ostali primjerci tava/zdjela nešto su kasnijeg datuma i pripadaju gruboj kasnoantičkoj keramici. Kao i lonci ove datacije, analogije nalaze na prostoru Friuli-Venezia Giulije, Istre i Slovenije. Na njima se javljaju i tipični urezani ukrasi. Morfološku sličnost pokazuju N-101-9, N-67-2 i N-55-3 (T. 13: 3–5) s prema unutra zadebljanim i istaknutim rubom čija je gornja površina ravna, a stijenke se zakošeno spuštaju prema dnu. Datacija ovog tipa smješta se od kraja 4. do početka 7. stoljeća, a analogiju nalazi u tipu I a i d s Invillina (Bierbrauer 1987: 190–193). Slične se posude javljaju i u Istri gdje je registrirana i strukturna sličnost s N-55-3 (T. 13: 5), no ove su posude, datirane u 6. stoljeće, ovdje interpretirane kao import s istočnog Mediterana (Višnjić et al. 2010: 234, T. 7-1, T. 7-8). Izvijeni profilirani rub sa zaobljenim stijenkama javlja se na N-5-9 (T. 13: 7) koji nalazi analogije u Osoppu i Invillinu (Negri 1994: 65). Tava/zdjela s ravnim rubom zadebljanim prema unutra i van i konkavnim stijenkama N-14-1 (T. 13: 6) nalazi analogije u Guranu, s datacijom u 5. do polovine 6. stoljeća (Ruffieux 2010: 254, pl. 5/GSC.08.25-11), no slična je i tipu Ic s Invillina (Bierbrauer 1987: 192).

Ulomak N-117-17 (T. 13: 8) nije jasno određeni predmet, no zbog svoje grube strukture mogli bismo ga smjestiti unutar kategorije kuhinjske keramike. Riječ je o ulomku ruba (stijenke) i dna plitke posude L-profila izrazito debelih stijenki, čija je unutarnja površina zaglađena, a rub je tek nepravilno narebren. Slične se posude javljaju u Istri gdje su interpretirane kao pladnjevi ili “pekači”, no u pravilu imaju ukrašeni rub (Marušić 1986: 66, n. 20; Višnjić et al. 2010: 235). Slični su tzv. *testi/testelli*, posude vrlo česte u Liguriji kroz srednjovjekovno razdoblje (Lavazza, Vitali 1994: 48–49, tav. 9: 11), no na širem tirenskom području (Ligurija, Toskana) pojavljuju se već u 5. stoljeću (Massari, Ratti 1977: 616–617, grupa 25, T. 195: 11). U svim varijantama, ove su posude služile za pečenje kruha ili sličnih tijesta.

Poklopci (T. 14, tab. 19)

U kategoriju kuhinjske keramika smještaju se i ulomci poklopaca o kojima nismo u mogućnosti donijeti konkretnije zaključke, s obzirom na to da je riječ o oblicama koji se zbog svoje funkcionalnosti nisu mijenjali kroz stoljeća.

Poklopci N-117-16 i N08-A5-20 (T. 14: 1–2) u STR. 12 posjeduje gotovo istovjetne karakteristike kao tava N08-A5-24 (T. 13: 1) za čije su pokrivanje mogli služiti (Riley 1979: 324, lid type 7).¹² Ulomak ruba N08-A5-21 (T. 14: 2) izrađen od iste strukture mogao bi se pripisati ovom tipu, iako nisu morfo-

they were presumably used as cooking ware.

Standing out in particular within this category is a pan rim shard with a groove for lid N-08-A5-24 (Pl. 13: 1), the so-called *tegami ad orlo bifido*. It is possible that base shard N-117-30 (Pl. 13: 2) with a relief groove also belongs to this type (and possibly to the same vessel). In view of its fabric (FAB 12, Tab. 26), which contains black inclusions of volcanic origin, as well as gold mica, we can conclude that this is a product of Campanian workshops from the 1st cent. BC to the 1st cent. AD, and not an African variant of the same form (Riley 1979: 247–250; Di Giovanni 1996: 78, type 2130; Topić 2004: 306). With pan N-08-A5-24 we associate lids of the same ceramic fabric, which are present at Fulfinum in three variants.¹¹ These vessels, together with corresponding lids, are common in the Eastern Adriatic, e.g. in Narona (Topić 2004: 306), Burnum – forum and amphitheatre (Zabehlicky Scheffenegger 1979: 32; Borzić 2014: 291), Tilurium (Šimić Kanaet 2010: 39, Pl. 281–282), Zadar (Glušćević 1990: 131, Pl. XVIII/1), however, the most important find of these vessels is the one from the underwater site of the Glavat promontory near the Mljet Island, where they make up 97.3% of the cargo, found “packed” together with lids/plates (Jurišić 2000: 29–30). In the underwater of the Eastern Adriatic these vessels were found also at the Gušteranski shipwreck near the Žirje Island, where they were associated with Forlimpopoli amphorae, as well as near the Galijula Island in the Palagruža Archipelago (Jurišić 2000: 30). From the Kvarner Gulf we know of a “Pompeii plate” shard from the underwater zone of the Ilovik Island (Jurišić 2000: 30). *Tegami ad orlo bifido* are the only products from the Southern Tyrrhenian coast of the Italian Peninsula documented so far at *Fulfinum* (and probably also in the wider area of the Kvarner Gulf), where they appear independently, that is, without associated jars typical for the Campanian cooking ware set (jar with slanted rim and jar with flat everted rim) (Di Giovanni, Soricelli 2013: 185).

The other specimens of pans/bowls are dated somewhat later and belong to coarse late antique pottery. Same as the jars dated in this way, they have analogies in Friuli-Venezia Giulia, Istria and Slovenia. They exhibit typical incised decorations. A morphological similarity is exhibited by N-101-9, N-67-2 and N-55-3 (Pl. 13: 3–5), with a pronounced rim thickened on the inside, whose upper surface is flat, while the walls taper towards the base. This type is dated between the end of the 4th and the beginning of the 7th cent., with an analogy in types I a and d from Invillino (Bierbrauer 1987: 190–193). Similar vessels are present also in Istria, where a similar fabric to N-55-3 (Pl. 13: 5) was documented, however, these vessels, dated to the 6th cent., were interpreted here as imports from the Eastern Mediterranean (Višnjić et al. 2010: 234, Pl. 7-1, Pl. 7-8). Everted profiled rim with rounded walls is present on N-5-9 (Pl. 13: 7), which has analogies in Osoppo and Invillino (Negri 1994: 65). Pan/bowl with flat rim thickened on the inside and outside and with concave walls N-14-1 (Pl. 13: 6) has analogies in Guran, which are dated to the 5th until the mid-6th cent. (Ruffieux 2010: 254, pl. 5/GSC.08.25-11), but it is also similar to type Ic from Invillino

¹² Vidi poglavlje o tavama za više informacija o ovom paru posuda.

¹¹ We will discuss this in more detail in the chapter on lids.

Crtež	Br. n.	SJ	Oblik/Struktura	Datacija	Analogija
T. 14: 1	N-117-16	Površinski nalaz u I.2	Rub poklopca / STR. 12	1. st. pr. Kr. – 2. st. po. Kr.	Topić 2004: T. 25: 96; Warner Slane 1990: 77, n. 158, Fig. 16
T. 14: 2	N08-A5-21	I.2002	Rub poklopca / STR. 12	1.pr. Kr. – 2. st. po. Kr.	Di Giovanni 1996: 2410
T. 14: 3	N08-A5-20	I.2002	Rub poklopca / STR. 12	1.pr. Kr. – 2. st. po. Kr.	Topić 2004: T. 25: 90
T. 14: 4	N08-A5-32	I.2002	Rub poklopca / STR. 15	1.–5. st.	Labate 1988: T. 47: g; Bloier 2012: T. 22: 2197
T. 14: 5	N-55-4	I.3010	Stijenka poklopca / STR. 18	Kasna antika	
T. 14: 6	N-131-28	I.4000	Drška poklopca / STR. 7	Kasna antika	
T. 14: 7	N-98-19	I.2101	Stijenka poklopca / STR. 11	Kasna antika	
T. 14: 8	N-117-29	Površinski nalaz u I.2	Rub poklopca / STR. 14	Kasna antika	
T. 14: 9	N07-A1-7	Površinski nalaz uz južne stube	Rub poklopca / STR. 1	Kasna antika	
Drawing	No. f.	SU	Form / Fabric	Date	Analogy
Pl. 14: 1	N-117-16	Surface find in I.2	Lid rim / FAB. 12	1 st century BC – 2 nd century AD	Topić 2004: Pl. 25: 96; Warner Slane 1990: 77, n. 158, Fig. 16
Pl. 14: 2	N08-A5-21	I.2002	Lid rim / FAB. 12	1 st century BC – 2 nd century AD	Di Giovanni 1996: 2410
Pl. 14: 3	N08-A5-20	I.2002	Lid rim / FAB. 12	1 st century BC – 2 nd century AD	Topić 2004: Pl. 25: 90
Pl. 14: 4	N08-A5-32	I.2002	Lid rim / FAB. 15	1 st -5 th century	Labate 1988: Pl. 47: g; Bloier 2012: Pl. 22: 2197
Pl. 14: 5	N-55-4	I.3010	Lid wall / FAB. 18	Late antiquity	
Pl. 14: 6	N-131-28	I.4000	Lid handle / FAB. 7	Late antiquity	
Pl. 14: 7	N-98-19	I.2101	Lid wall / FAB. 11	Late antiquity	
Pl. 14: 8	N-117-29	Surface find in I.2	Lid rim / FAB. 14	Late antiquity	
Pl. 14: 9	N07-A1-7	Surface find next to the southern staircase	Lid rim / FAB STR. 1	Late antiquity	

Tab. 19 Kuhinjska keramika, poklopci
Tab. 19 Cooking ware, lids

loški posve istovjetni, pa bismo ga mogli usporediti s tipom 2410 iz Pompeja (Di Giovanni 1996: 96).

Osim navedenih poklopaca, nešto preciznija odrednica moguća je kod ulomaka N08-A5-32 (T. 14: 4), no i njegova je kronologija nešto šira (1. – 5. stoljeće) (Labate 1988: 75; Bloier 2012: 325, n. 2197). Za ostale primjerke, na osnovi strukture, možemo pretpostaviti kasnoantičku dataciju.

Afričko kuhinjsko posuđe (T. 15, tab. 20)

U kategoriju kuhinjskog posuđa sjevernoafričkog podrijetla smještamo jedan ulomak ruba lonca C/A proizvodnje (sjeverni Tunis), N-16-1 (T. 15: 1), oblika Hayes 197 (Bonifay type 10, Bonifay 2004: 224–225) koji datira od kraja 2. i u 3. stoljeće. Istoj proizvodnji, no nešto ranijoj dataciji (kraj 1. do 2. stoljeće) pripada ulomak tave s *orlo bifido* N-143-2 (T. 15: 2), tip Ostia II, 306/Luni “patina cinerognola” tipo III (Carandini 1970: 84, forma IIa; Roffia 1976: 185; Tortorella 1981: 216) čiji oblik potječe od italskih republikanskih tipova (Bonifay 2004: 225). Ostali ulomci tuniske C/A proizvodnje pripadaju poklopcima. Uz N-16-1 (T. 15: 1) mogli bismo povezati poklopac N-39-1 (T. 15: 3), s obzirom na da su ova dva oblika inače interpretirana kao komplementarna, a prema oblikovanju

(Bierbrauer 1987: 192).

Although shard N-117-17 (Pl. 13: 8) has not been clearly determined, its coarse fabric suggests attribution to the cooking ware category. This is a rim (wall) and base shard of a shallow L-profiled vessel with exceptionally thick walls, with smoothed interior surface and irregularly ribbed rim. Similar vessels appear in Istria, where they are interpreted as platters or “baking plates”, but as a rule they feature a decorated rim (Marušić 1986: 66, n. 20; Višnjic et al. 2010: 235). Similar to these are the so-called *testi/testelli*, vessels that are very common in Liguria during the Middle Ages (Lavazza, Vitali 1994: 48–49, tav. 9: 11), however, in the wider Tyrrhenian region they appeared already in the 5th cent. (Massari, Ratti 1977: 616–617, group 25, Pl. 195: 11). In all the variants, these vessels were used for baking bread or similar dough.

Lids (Pl. 14, Tab. 19)

The cooking ware category includes also lid shards, about which we are unable to reach any definite conclusion, considering that due to their functional features these forms had not changed through cent..

Crtež	Br. n.	SJ	Oblik / Struktura	Datacija	Analogija
T. 15: 1	N - 16 - 1	I.3002	Rub lonca / Culinaire C/A	Kasno 2. – 3. st.	Hayes 197, Bonifay 2004: Fig. 120: 3
T. 15:2	N-143-2	I.2101	Tava / Culinaire C/A	Kraj 1. – pol. 2. st.	Carandini 1970: Fig. 306–307; Ruffia 1976: T. 122: 7; Tortorella 1981: T. CVI: 7
T. 15: 3	N-39-1	I.3002	Poklopac / Culinaire C/A	3. st.	Hayes 196, Bonifay type 11A (Bonifay 2004: 225–226, Fig. 121)
T. 15: 4	N08-A1-2	I.2003	Poklopac / Culinaire C/A	4. – početak 5. st.	Hayes 196, Bonifay type 11 tardive (Bonifay 2004: 225–226, Fig. 121)
T. 15: 5	N-101-10	I.2101	Poklopac / Culinaire B	Kraj 1. – 2. st.	Hayes 185, Bonifay type 9A (Bonifay 2004: 221, Fig. 118)
T. 15: 6	N-5-8	I.3002	Poklopac / Culinaire B	Kraj 2. st. – 3. st.	Hayes 182, Bonifay type 6 (Bonifay 2004: 217, Fig. 116)
T. 15: 7	N08-A1-3	I.2003	Poklopac / Culinaire B	Kraj 2. st. – 3. st.	Hayes 182, Bonifay type 6 Bonifay type 6 (Bonifay 2004: 217, Fig. 116)
Drawing	No. f.	SU	Form / Fabric	Date	Analogy
Pl. 15: 1	N - 16 - 1	I.3002	Jar rim / Culinaire C/A	Late 2 nd -3 rd century	Hayes 197, Bonifay 2004: Fig. 120: 3
Pl. 15:2	N-143-2	I.2101	Pan / Culinaire C/A	End of 1 st – mid-2 nd century	Carandini 1970: Fig. 306–307; Ruffia 1976: Pl. 122: 7; Tortorella 1981: Pl. CVI: 7
Pl. 15: 3	N-39-1	I.3002	Lid / Culinaire C/A	3 rd century	Hayes 196, Bonifay type 11A (Bonifay 2004: 225–226, Fig. 121)
Pl. 15: 4	N08-A1-2	I.2003	Lid / Culinaire C/A	4 th century – beginning of 5 th century	Hayes 196, Bonifay type 11 tardive (Bonifay 2004: 225–226, Fig. 121)
Pl. 15: 5	N-101-10	I.2101	Lid / Culinaire B	End of 1 st -2 nd century	Hayes 185, Bonifay type 9A (Bonifay 2004: 221, Fig. 118)
Pl. 15: 6	N-5-8	I.3002	Lid / Culinaire B	End of 2 nd -3 rd century	Hayes 182, Bonifay type 6 (Bonifay 2004: 217, Fig. 116)
Pl. 15: 7	N08-A1-3	I.2003	Lid / Culinaire B	End of 2 nd -3 rd century	Hayes 182, Bonifay type 6 Bonifay type 6 (Bonifay 2004: 217, Fig. 116)

Tab. 20 Afrička kuhinjska keramika

Tab. 20 African cooking ware

rubu ovaj ulomak smještamo u tip 11A po Bonifayu te ga prema tome datiramo u 3. stoljeće (Bonifay 2004: 225–226). Istom tipu, ali kasnoj varijanti (4.–5. stoljeće), mogli bismo pripisati ulomak ruba poklopca N08-A1-2 (T. 15: 4) (Bonifay 2004: 225–226).

Ulomak poklopca N-101-10 (T. 15: 5) pripada afričkoj kuhinjskoj keramici B (podrijetlom iz Bizacene), preciznije tipu Hayes 185 te datira u 1. do 2. stoljeće (Bonifay 2004: 221). Iste keramičkoj strukturi pripadaju i ulomci poklopca N-5-8 (T. 15: 6) i N08-A1-3 (T. 15: 7) koje pripisujemo tipu Hayes 182 s datacijom od kraja 2. u 3. stoljeća (Bonifay 2004: 216–27).

Afričko posuđe identificirano je na *Fulfinumu* i tijekom ranijih istraživanja (Pavišić 1983: 44, T. I: 4) i to oblik Hayes 23/Bonifay type 1 (proizvodnja A – vjerojatno sjeverni Tunis), no zbog teške definicije točnijeg tipa, ulomak bismo datirali od 2. do početka 4. stoljeća (Bonifay 2004: 211, 221). Tip Hayes 197 prisutan je i u Senju (Fadić 1999: 54, T. 5/32,33, T. 6/40). Afričko kuhinjsko posuđe brojno je i na drugim lokalitetima duž istočnog Jadrana (npr. Topić 2004: 307; Šimić-Kanaet 2010: 27; Jelinčić Vučković 2011: 132–133; Borzić 2014: 291–292).

Kuhinjska keramika upitne provenijencije (T. 15, tab. 21)

Lonac N-101-8 (T. 15: 8) koji morfološki podsjeća na oblik afričke kuhinjske keramike Hayes 183/184 teško je odrediti

Lids N-117-16 and N08-A5-20 (Pl. 14: 1–2) in FAB. 12 have almost identical features as pan N08-A5-24 (Pl. 13: 1), which they may have covered (Riley 1979: 324, lid type 7).¹² Rim shard N08-A5-21 (Pl. 14: 2), made of the same fabric, might be attributed to this type, even though they are not completely identical, so we might compare it with type 2410 from Pompeii (Di Giovanni 1996: 96).

In addition to the mentioned lids, shard N08-A5-32 (Pl. 14: 4) can also be determined relatively precisely, although its chronology is rather wide (1st – 5th cent.) (Labate 1988: 75; Bloier 2012: 325, n. 2197). For other specimens, based on the fabric, we may suppose a date in late antiquity.

African cooking ware (Pl. 15, Tab. 20)

In the category of cooking ware of North African origin we include a rim shard of a jar of C/A production (northern Tunisia), N-16-1 (Pl. 15: 1) of Hayes 197 type (Bonifay type 10, Bonifay 2004: 224–225), dated from the end of the 2nd until the 3rd cent.. To the same production, albeit of an earlier date (end of the 1st until the 2nd cent.), belongs a shard of an *orlo bifido* pan N-143-2 (Pl. 15: 2), type Ostia II, 306/Luni “patina cinerognola” tipo III (Carandini 1970: 84, forma IIa; Roffia 1976: 185; Tortorella 1981: 216), whose form is derived from Italic republican types (Bonifay 2004: 225). The other shards

¹² See the chapter on pans for more information about this pair of vessels.

Crtež	Br. n.	SJ	Oblik / Struktura	Datacija	Analogija
T. 15: 8	N-101-8	I.2101	Rub lonca ili veće zdjele / STR. 16	Pol. 1. st. pr. Kr. – 4. st. po. Kr.	Starac, A. 2006: T. XIX: n. 305; Rupel 1991: T. 24: CCd39; Labate 1988: tav. 35: e; Hayes 183/184, Bonifay type 7/15
T. 15: 9	N13-A1-5	I.2100; I.2101; I.2103	Poklopac / STR. 19	Pol. 1. st. – pol. 3. st.	Hayes 1983: 122
Drawing	No. f.	SU	Form / Fabric	Date	Analogy
Pl. 15: 8	N-101-8	I.2101	Rim of a jar or large bowl / FAB. 16	Mid-1 st century BC – 4 th century AD	Starac, A. 2006: Pl. XIX: n. 305; Rupel 1991: Pl. 24: CCd39; Labate 1988: tav. 35: e; Hayes 183/184, Bonifay type 7/15
Pl. 15: 9	N13-A1-5	I.2100; I.2101; I.2103	Lid / FAB. 19	Mid-1 st century – mid-3 rd century	Hayes 1983: 122

Tab. 21 Kuhinjska keramika upitne provenijencije

Tab. 21 *Cooking ware of dubious origin*

s obzirom na to da je njegova struktura sasvim različita od tipičnih afričkih struktura i ne posjeduje premaz/zaglađivanje nego je njegova površina hrapava. Moguće je da je ulomak gorio te da je zbog toga njegova struktura promijenjena. No, prema Bonifayu ovaj je oblik dosta rijedak izvan Afrike (Bonifay 2004: 217), iako se u Naroni javlja sa sedam primjeraka (Topić 2004: 360–361, T. 49, 50: 235–236). Zbog navedenog valja uzeti u obzir i druge interpretacije sličnih posuda koje daju pojedini autori, na primjer u Akvileji i Puli (Rupel 1991: 164; Starac, A. 2006: 59, 122), te na drugim lokalitetima sjeverne Italije (npr. okolica Modene, Labate 1988: 63), gdje su mahom interpretirane kao regionalni tip/lokalna proizvodnja (Rupel 1991: 162; Starac, A. 2006: 59). Osim toga, primjerci iz Italije datirani su ranije, od polovine 1. te kroz 2. stoljeće, tek iznimno kasnije, dok afrički primjerci datiraju od druge polovine 3. i kroz 4. stoljeće, odnosno manji primjerci od kraja 2./početka 3. stoljeća (Bonifay 2004: 229).

Poklopac N13-A1-5 (T. 15: 9) također je upitne provenijencije jer se morfološki ne ističe osim po vidljivim kanelirama nastalim obradom na kolu. Ipak, s obzirom na njegovu strukturu, mogli bismo ga smjestiti u istočnomediteransku proizvodnju, npr. poklopce Hayes Knossos 75 kakvi se javljaju i u Naroni te na nekoliko jadranskih brodoloma (Hayes 1983: 122, Fig. 6/75; Topić 2004: 307, 352, T. 43 i literatura).

Keramičke uljanice¹³ (T. 16–18, sl. 1, tab. 22)

Od 2007. do 2013. godine na forumu *Fulfinuma* pronađeno je ukupno 68 ulomaka koje možemo pripisati raznim dijelovima uljanica. Ulomci za koje je bilo moguće definirati tip pripadaju poglavito ranocarskim tipovima Loeschke I–V (volutne uljanice), Loeschke VII/VIII i uljanicama tipa *Firmalampen*, iako je za većinu vrlo teško preciznije odrediti tip. Tek jedan ulomak drške, N-14-4 (T. 18: 13), možemo identificirati s kasnoantičkim tipom uljanice Atlante VIII (graf. 4). Mahom je riječ o vrlo sitnim ulomcima sa zaobljenim lomovima, što je u većini slučajeva onemogućilo identificiranje

13 Za klasifikaciju tipova ukrasa na volutnim uljanicama u većini je slučajeva korištena tipologija E. Di Filippo Balestrazzi (Di Filippo Balestrazzi 1988) razrađena za Akvileju, jer je upravo s ovom tipologijom uočeno najviše podudarnosti. U tab. 21 kratica DFB odnosi se na navedenu publikaciju, dok su tipovi definirani prema Loeschke 1919, na što se odnosi kratica L i rimski broj.

of Tunisian C/A production belong to lids. With N-16-1 (Pl. 15: 1) we might associate lid N-39-1 (Pl. 15: 3), considering that these two forms are generally interpreted as complementary, while based on the shape of the rim we attribute this shard to type 11A after Bonifay, and therefore date it to the 3rd cent. (Bonifay 2004: 225–226). To the same type, although a late variant (4th–5th cent.) we might attribute a lid rim shard N08-A1-2 (Pl. 15: 4) (Bonifay 2004: 225–226).

Lid shard N-101-10 (Pl. 15: 5) belongs to African cooking ware B (with origin from Bizacena), more precisely type Hayes 185, and it is dated to the 1st to 2nd cent. (Bonifay 2004: 221). The same ceramic fabric is shared also by lid shards N-5-8 (Pl. 15: 6) and N08-A1-3 (Pl. 15: 7), which we attribute to type Hayes 182, dated from the end of the 2nd until the 3rd cent. (Bonifay 2004: 216–27).

African pottery was identified at *Fulfinum* already during previous excavations (Pavišić 1983: 44, Pl. I: 4), namely Hayes 23/Bonifay type 1 (production A – probably northern Tunisia), however, since the type is difficult to ascertain, we would date the shard from the 2nd until the beginning of the 4th cent. (Bonifay 2004: 211, 221). Type Hayes 197 is present also in Senj (Fadić 1999: 54, Pl. 5/32, 33, Pl. 6/40). African cooking ware is abundant also at other sites along the Eastern Adriatic coast (e.g. Topić 2004: 307; Šimić-Kanaet 2010: 27; Jelinčić Vučković 2011: 132–133; Borzić 2014: 291–292).

Cooking ware of dubious origin (Pl. 15, Tab. 21)

Jar N-101-8 (Pl. 15: 8), which is morphologically reminiscent of Hayes 183/184 form of African cooking ware, is difficult to determine since its fabric is completely different from typical African fabrics and lacks the slip/smoothing, having instead a rough surface. It is possible that this shard had burned, which may have caused a change in fabric. However, in Bonifay's opinion this form is relatively rare outside Africa (Bonifay 2004: 217), even though it is present in Naroni with seven specimens (Topić 2004: 360–361, Pl. 49, 50: 235–236). Due to what was mentioned we ought to also consider other interpretations of similar vessels put forward by certain authors, for instance in Aquileia and Pula (Rupel 1991: 164; Starac, A. 2006: 59, 122), as well as in other sites in Northern Italy (e.g. surroundings of Modena, Laba-

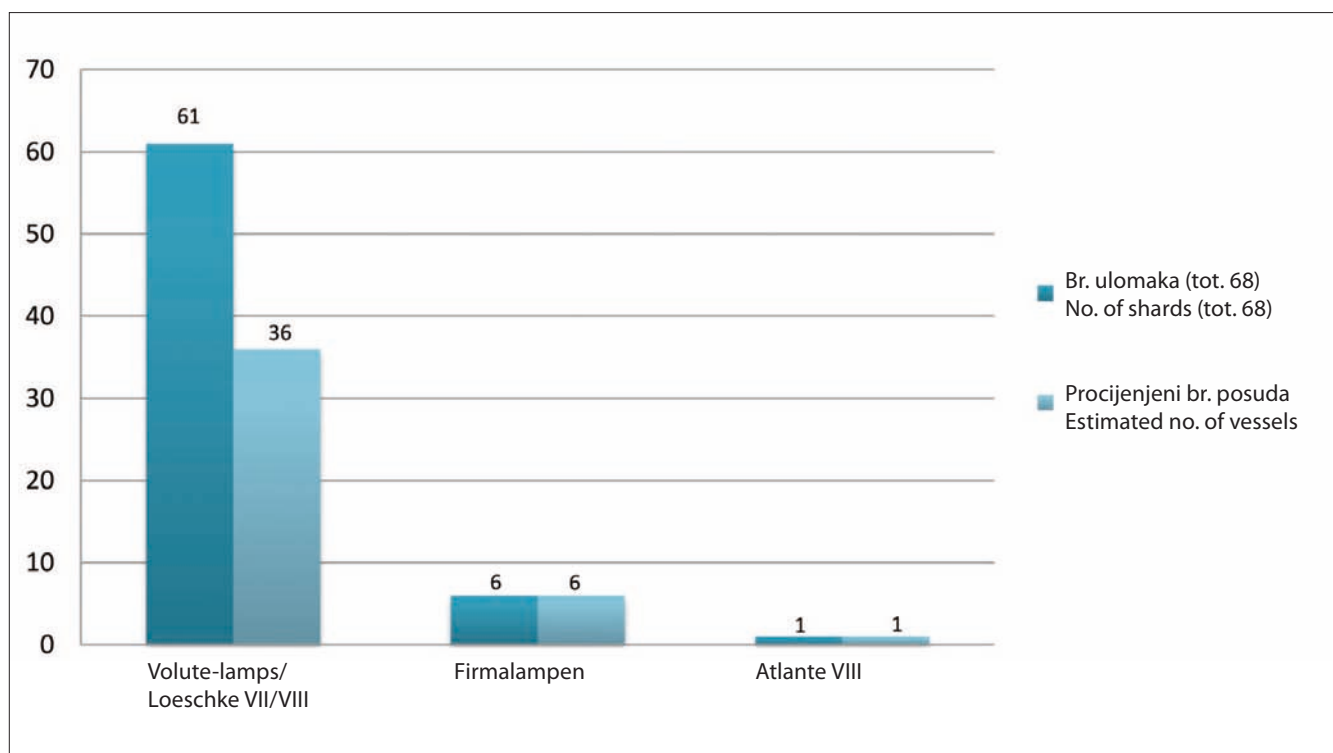

Graf. 4 Keramičke uljanice: procijenjeni broj posuda/broj ulomaka prema tipu
 Graph 4 Ceramic oil lamps: estimated number of vessels/number of shards by type

eventualnih spojeva, no ipak je pokušana procjena broja posuda: 37 volutnih/Loeschke VII/VIII uljanica, šest *Firmalampen* i jedna Atlante VIII.

Ulomci volutnih uljanica brojniji su (61 ulomak), ali su i nešto bolje sačuvani, tako je na šest ulomka bilo moguće rekonstruirati ukras na disku (N-108-1 – sl. 1: 1, N-109-1 – sl. 1: 2, N-92-4 – sl. 1: 3, N-117-18 – T. 16: 3, N-117-19 – T. 16: 4, N-131-39 – T. 16: 2). U slučaju N-108-1 (sl. 1: 1) bilo je moguće spojiti dio kljuna, ramena i diska (te možda dna) volutne uljanice tipa Loeschke I/IIIa s reljefnim prikazom psa u trku prema lijevo (Ožanić Roguljić, Konestra 2012). Osim navedene cjelovitije uljanice s prikazom psa, uočen je ulomak diska s prikazom čovjeka (boksač?) (N-92-4, sl. 1: 3) i ulomci diska s prikazom jarca u ležećem stavu prema desno (N-109-1, sl. 1: 2) (Ožanić Roguljić, Konestra 2012). Ostali ulomci ukrašenog diska pripadaju ukrasu rozeta s više ili manje latica (Ožanić Roguljić, Konestra 2012). Strukture keramike volutnih uljanica variraju od vrlo svijetle bež boje do svijetloružičaste, a uvijek su jako pročišćene, mekane i prašnjave na dodir. Premazi variraju od crvenog do gotovo crnog, iako se u većini slučajeva premaz nije sačuvao. Ulomak ručke N-138-7 (T. 18: 6) nije moguće preciznije vezati uz određeni tip, pa bi on mogao pripadati kako volutnoj (Loeschke I/IV) tako i uljanici tipova Loeschke VII/VIII. Najraniji primjeri volutnih uljanica datiraju na kraj 1. st. pr. Kr., no njihov se razvoj prati kroz cijelo prvo stoljeće do prve četvrtine 2. stoljeća (Trajan), a s obzirom na to da fulfinske nalaze u većini slučajeva nije moguće preciznije odrediti, datirali bismo ih upravo u 1. i prvu polovinu 2. st. pos. Kr. (Di

te 1988: 63), where they were by and large interpreted as a regional type/local production (Rupel 1991: 162; Starac, A. 2006: 59). Besides, the specimens from Italy were dated to an earlier time, from the mid-1st cent. through the 2nd cent., and only exceptionally later, while African specimens date from the second half of the 3rd cent. and through the 4th cent., or in case of smaller specimens, from the end of the 2nd c./beginning of the third cent. (Bonifay 2004: 229).

Lid N13-A1-5 (Pl. 15: 9) is also of dubious origin, because in terms of morphology it does not stand out except for the visible flutes brought about by the processing on the wheel. However, in view of its fabric, we might attribute it to the Eastern Mediterranean production, e.g. lids of Hayes Knossos 75 type, which appear also in Naronia and at several Adriatic shipwrecks (Hayes 1983: 122, Fig. 6/75; Topić 2004: 307, 352, Pl. 43 and bibliography).

Ceramic oil lamps¹³ (Pl. 16-18, Fig. 1, Tab. 22)

The investigations at the forum of *Fulfinum* between 2007 and 2013 yielded a total of 68 shards attributable to different parts of oil lamps. Shards that could be attributed to a specific type primarily belong to early imperial types Loeschke I-V (volute-lamps), Loeschke VII/VIII and *Firmalampen* types, although in most cases the type is difficult

¹³For the classification of types of decoration on volute-lamps in most cases we used the typology that E. Di Filippo Balestrazzi (Di Filippo Balestrazzi 1988) worked out for Aquileia, as it proved as the most compatible one with our situation. The abbreviation DFB in T. 21 refers to that publication, while the types were defined after Loeschke 1919, which is referred to by the abbreviation L and a Roman numeral.



Sl. 1 Ukrašeni diskovi uljanica – 1. N-108-1, 2. N-109-1, 3. N-92-4 (fotografije: A. Konestra)

Fig. 1 Decorated parts of oil lamps – 1. N-108-1, 2. N-109-1, 3. N-92-4 (photos by A. Konestra)

Filippo Balestrazzi 1988: 153–303). Ako N-138-7 (T. 18: 6) ne pripada volutnoj uljanici, njegova bi datacija mogla biti nešto kasnija, odnosno do u 3. stoljeće (Di Filippo Balestrazzi 1988: 334–335). Preciznije datacije za pojedine ulomke donosimo u tablici (tab. 21).

Firmalampen ili uljanice otvorenog kanala javljaju se usporedno s volutnima, iako se za njih pretpostavlja nešto kasnija pojava, odnosno 1. st. pos. Kr., a ove se lampice javljaju sve do 5.–6. stoljeća (Buchi 1975: XXIX–XXXIII), no pred kraj proizvodnje njihova kvaliteta osjetno slabi (oblik postaje nepravilan, detalji su realizirani vrlo površno, gubi se uglatost na prijelazima i sl.). S obzirom na relativno dobru kvalitetu fulfinskih primjeraka (6 ulomaka: T. 08 NA-4-1 – T. 18: 7, 08 NA-5-35 – T. 18: 8, 08 NA-5-36 – T. 18: 9, 08 NA-5-6 – T. 18: 10, N-138-6 – T. 18: 11, 08 NA-6-2 – T. 18: 12), njihova bi datacija bila bliža početku proizvodnje, dakle mogle bi pripadati 1. i 2. st. pos. Kr. Keramička struktura ovih uljanica u pravilu je kompaktnija i tamnije narančaste boje, s ponekad vidljivim primjesama (kalcit?).

Kasnoantičkim “afričkim” uljanicama pripada tek jedan ulomak drške (N-14-4, T. 18: 13) čije karakteristike govore u

to ascertain. There is only one handle shard, N-14-4 (Pl. 18: 13), that could be identified with the late antique oil-lamp type Atlante VIII (graph 4). By and large we are dealing with very small shards with rounded breaks, which in most cases prevented the identification of potential refitting. In spite of that, we attempted to estimate the number of vessels: 37 volute-lamps/Loeschke VII/VIII lamps, six *Firmalampen* and one Atlante VIII lamp.

Volute-lamp shards are more numerous (61 shards), but also better preserved, so that in six cases it was possible to reconstruct the decoration on the disc (N-108-1 – Fig. 1: 1, N-109-1 – Fig. 1: 2, N-92-4 – Fig. 1: 3, N-117-18 – Pl. 16: 3, N-117-19 – Pl. 16: 4, N-131-39 – Pl. 16: 2). In case of N-108-1 (Fig. 1: 1) it was possible to conjoin a part of the spout, shoulder and disc (and perhaps also the base) of a volute-lamp of Loeschke I/IIIa type with a relief depiction of a dog running towards left (Ožanić Roguljić, Konestra 2012). In addition to the mentioned almost complete oil-lamp with the depiction of a dog, we also noted a disc shard depicting a man (boxer?) (N-92-4, Fig. 1: 3) and fragments of a disc with the depiction of a he-goat in the recumbent posture towards right (N-109-1, sl. 1: 2) (Ožanić Roguljić, Konestra 2012). The other fragments of decorated discs belong to rosettes with a higher or lesser number of petals (Ožanić Roguljić, Konestra 2012). Ceramic fabrics of volute-lamps vary from very bright beige to bright rosy colour, and they are always very well levigated, soft and dusty on touch. Slips vary from red to almost black, although in most cases the slip was not preserved. Handle fragment N-138-7 (Pl. 18: 6) cannot be definitely associated with a specific type, so it might belong to a volute-lamp (Loeschke I/IV), as much as to a lamp of Loeschke VII/VIII types. The earliest specimens of volute-lamps date from the end of the 1st cent. BC, but their evolution may be traced throughout the first cent. AD until the first quarter of the 2nd cent. (Trajan), and considering that the Fulfinum finds in most cases cannot be determined with any precision, we would be inclined to date them precisely to the 1st cent. and the first half of the 2nd cent. AD (Di Filippo Balestrazzi 1988: 153–303). If N-138-7 (Pl. 18: 6) does not belong to a volute-lamp, then it might be dated somewhat later, that is, until the 3rd cent. (Di Filippo Balestrazzi 1988: 334–335). More precise datings for certain shards are presented in Table 21.

Firmalampen, or open-groove oil lamps are present parallel with volute-lamps, even though these presumably appeared somewhat later, in the 1st cent. AD, while those lamps endured until the 5th–6th cent. (Buchi 1975: XXIX–XXXIII), although towards the end of their production their quality grew considerably poorer (form became irregular, details executed very superficially, angularity at transitions was lost etc.). In view of the relatively good quality of specimens from Fulfinum (6 shards: Pl. 08 NA-4-1 – Pl. 18: 7, 08 NA-5-35 – Pl. 18: 8, 08 NA-5-36 – Pl. 18: 9, 08 NA-5-6 – Pl. 18: 10, N-138-6 – Pl. 18: 11, 08 NA-6-2 – Pl. 18: 12), they would likely be dated closer to the beginning of the production, in other words, they might belong to the 1st and 2nd cent. AD. The ceramic fabric of these oil lamps is generally more compact and has a darker orange colour, sometimes with

Crtež	Br. n.	SJ	Opis	Kol.	Tip	Datacija	Analogija
T. 16: 1	13 N-A1-3	I.2100; I.2101; I.2103;	Ulomaka ramena i diska s tragom ukrasa	1	L I-IV	1.-2. st.	
T. 16: 2	N-131-39	I.4000	Ulomak ramena i ukrašenog diska – rozeta	1	L I/IIIa	1.-2. st.	DFB IV.c.8.2.4
T. 16: 3	N-117-18	I.2	Ulomak ramena i diska volutne uljanice s ukrasom rozete (vidljive 4 latice)	1	L I-IV	1.-2. st.	DFB IV.c.8.2.4
T. 16: 4	N-117-19	I.2	Ulomak ramena i diska volutne uljanice s ukrasom rozete (vidljive 2 latice)	1	L I-IV	1.-2. st.	DFB IV.c.8.
T. 16: 5	N-117-20	I.2	Ulomak ramena i diska s tragom ukrasa	1	L I-IV	1.-2. st.	
T. 16: 6	08 NA-5-9	I.2002	Ulomak ramena i diska s tragom ukrasa	1	L I-IV	1.-2. st.	
T. 16: 7	N-131-40	I.4000	Ulomak ramena i rezervoara s ostatkom volute	1	L I, III, IV	1.-2. st.	
T. 16: 8	N-117-22	I.2	Ulomak ramena i rezervoara s ostatkom volute / crni premaz	1	L I, III, IV	1.-2. st.	
T. 16: 9	N-117-23	I.2	Ulomak rezervoara s ostatkom volute / crveni premaz	1	L I, III, IV	1.-2. st.	
T. 16: 10, 11	N-124-1-2	I.2101	Ulomci ramena s volutom i dna	2	L I, III, IV	1.-2. st.	
T. 16: 12	N-101-12	I.2101	Ulomak ramena	1	L I-IV	1.-2. st.	
T. 16: 13	N-131-41	I.4000	Ulomak ramena	1	L I-IV	1.-2. st.	
T. 16: 14	N-117-24	I.2	Ulomci ramena	2	L I-IV	1.-2. st.	
T. 16: 15	N-117-28	I.2	Ulomak ramena	1	L I-IV	1.-2. st.	
T. 17: 1-5	N-60-7 (1-5)	I.3019	Ulomci ramena, dna i rezervoara (vjerojatno istovjetna uljanica)	9	Volutna	1.-2. st.	
T. 17: 6	N-53-7	I.3014	Ulomci ramena i diska / smeđecrni premaz	1	L I/III	1.-2. st.	
T. 17: 7	N-53-8	I.3014	Ulomci ramena i diska / tamnocrveni premaz	1	L I-IV	1.-2. st.	
T. 17: 8	N-92-2	I.3017	Ulomak rezervoara uljanice / crni premaz	1	L I-IV	1.-2. st.	
T. 17: 9	08 NA-5-8	I.2002	Ulomak ramena	1	L I-IV	1.-2. st.	
T. 17: 10	08 NA-5-33	I.2002	Ulomak ramena	1	L I-IV	1.-2. st.	
T. 17: 11	08 NA-5-34	I.2002	Ulomak ramena	1	L I/IIa	1.-2. st.	
T. 17: 12	N-117-27	I.2	Ulomak ramena	1	L I-IV	1.-2. st.	
T. 17: 13	08 NA-6-1	Površinski nalaz uz južni zid	Ulomak dna uljanice	1	L I, III, IV	1.-2. st.	
T. 17: 14, 15	08 NA-5-7, 7-7/2	I.2002	Ulomci ramena, dijela diska i kljuna	3	L I/IIIb	1.-2. st.	
T. 18: 1	N-117-21	I.2	Ulomak kljuna	1	L I	1.-2. st.	
T. 18: 2	N-101-13	I.2101	Ulomak kljuna / zacrnjeni otvor	1	L I	1.-2. st.	
T. 18: 3	N-92-3	I.3017	Ulomak kljuna i rezervoara s volutom / crveni premaz	1	L I, III, IV	1.-2. st.	
T. 18: 4	N-117-26	I.2	Ulomak kljuna na spoju s ramenom	1	L I	1.-2. st.	
T. 18: 5	N-117-25	I.2	Ulomak dna uljanice	1	Volutna?	1.-2. st.	
T. 18: 6	N-138-7	I.2121	Ulomak drške	1	L. II, IV, V, VII, VIII	1.-3. st.	
T. 18: 7	08 NA-4-1	I.2001	Ulomak ramena	1	<i>Firmalampen</i>	1.-3. st.	
T. 18: 8	08 NA-5-35	I.2002	Ulomak ramena	1	<i>Firmalampen</i>	1.-3. st.	
T. 18: 9	08 NA-5-36	I.2002	Ulomak ramena sa zakovicom	6	<i>Firmalampen</i>	1.-3. st.	
T. 18: 10	08 NA-5-6	I.2002	Ulomak ramena	1	<i>Firmalampen</i>	1.-3. st.	
T. 18: 11	N-138-6	I.2121	Ulomak ramena sa zakovicom i diska	1	<i>Firmalampen</i>	1.-3. st.	
T. 18: 12	08 NA-6-2	Površinski nalaz uz južni zid	Ulomak kljuna	1	<i>Firmalampen?</i>	1.-3. st.	
T. 18: 13	N-14-4	I.3006	Ulomak drške uljanice	1	Atlante VIII	od 5. st.	Bonifay 2004: 358–370
Sl. 1: 1	N-108-1	I.2101	Ulomci diska, ramena i dna / prikaz psa u trku nalijevo	8	L IB/IIIa		Bailey 1980: Q821
Sl. 1: 2	N-109-1	I.2101	Ulomak diska s prikazom jarca u ležećem položaju	2	L I-IV?		DFB III.a.13.4, VB t. VI, 5
Sl. 1: 311	N-92-4	I.3017	Ukrašeni ulomak diska / prikaz gladijatora/boksača	1	L I-IV?		
/	N-101-14	I.2101	Ulomak rezervoara / tamosmeđe-crni premaz	1	L I-IV?		
/	N-53-9	I.3014	Ulomak ramena	1	L I-IV?		
/	N-92-1	I.3017	Ulomak rezervoara uljanice / crveni premaz	1			
UKUPAN BROJ ULOMAKA:				68			

Tab. 22 Keramičke uljanice (Kratica DBF odnosi se na tipologiju Di Filippo Balestrazzi 1988, kratica L na tipologiju Loeschke 1919)

Drawing	No. f.	SU	Description	Qt.	Type	Date	Analogy
Pl. 16: 1	13 N-A1-3	I.2100; I.2101; I.2103;	Shoulder and disc shard with remains of decoration	1	L I-IV	1 st -2 nd century	
Pl. 16: 2	N-131-39	I.4000	Shoulder and decorated disc shard - rosette	1	L I/IIIa	1 st -2 nd century	DFB IV.c.8.2.4
Pl. 16: 3	N-117-18	I.2	Shoulder and disc shard of a volute-lamp with rosette decoration (4 petals visible)	1	L I- IV	1 st -2 nd century	DFB IV.c.8.2.4
Pl. 16: 4	N-117-19	I.2	Shoulder and disc shard of a volute-lamp with rosette decoration (2 petals visible)	1	L I- IV	1 st -2 nd century	DFB IV.c.8.
Pl. 16: 5	N-117-20	I.2	Shoulder and disc shard with remains of decoration	1	L I- IV	1 st -2 nd century	
Pl. 16: 6	08 NA-5-9	I.2002	Shoulder and disc shard with remains of decoration	1	L I-IV	1 st -2 nd century	
Pl. 16: 7	N-131-40	I.4000	Shoulder and container shard with remains of the volute	1	L I, III, IV	1 st -2 nd century	
Pl. 16: 8	N-117-22	I.2	Shoulder and container shard with remains of the volute / black slip	1	L I, III, IV	1 st -2 nd century	
Pl. 16: 9	N-117-23	I.2	Container shard with remains of the volute / red slip	1	L I, III, IV	1 st -2 nd century	
Pl. 16: 10, 11	N-124-1-2	I.2101	Shoulder shards with volute and base	2	L I, III, IV	1 st -2 nd century	
Pl. 16: 12	N-101-12	I.2101	Shoulder shard	1	L I- IV	1 st -2 nd century	
Pl. 16: 13	N-131-41	I.4000	Shoulder shard	1	L I- IV	1 st -2 nd century	
Pl. 16: 14	N-117-24	I.2	Shoulder shard	2	L I- IV	1 st -2 nd century	
Pl. 16: 15	N-117-28	I.2	Shoulder shard	1	L I- IV	1 st -2 nd century	
Pl. 17: 1-5	N-60-7 (1-5)	I.3019	Shoulder, base and container shards (probably from the same oil lamp)	9	Volute-lamp	1 st -2 nd century	
Pl. 17: 6	N-53-7	I.3014	Shoulder and disc shards / brown-black slip	1	L. I/III	1 st -2 nd century	
Pl. 17: 7	N-53-8	I.3014	Shoulder and disc shards / dark red slip	1	L I- IV	1 st -2 nd century	
Pl. 17: 8	N-92-2	I.3017	Oil-lamp container shard / black slip	1	L I- IV	1 st -2 nd century	
Pl. 17: 9	08 NA-5-8	I.2002	Shoulder shard	1	L I-IV	1 st -2 nd century	
Pl. 17: 10	08 NA-5-33	I.2002	Shoulder shard	1	L I-IV	1 st -2 nd century	
Pl. 17: 11	08 NA-5-34	I.2002	Shoulder shard	1	L I/IIa	1 st -2 nd century	
Pl. 17: 12	N-117-27	I.2	Shoulder shard	1	L I- IV	1 st -2 nd century	
Pl. 17: 13	08 NA-6-1	Surface find next to the southern wall	Oil-lamp base shard	1	L I, III, IV	1 st -2 nd century	
Pl. 17: 14, 15	08 NA-5-7, 7 - 7/2	I.2002	Shards from a shoulder, part of the disc and spout	3	L I/IIIb	1 st -2 nd century	
Pl. 18: 1	N-117-21	I.2	Spout shard	1	L I	1 st -2 nd century	
Pl. 18: 2	N-101-13	I.2101	Spout shard / blackened opening	1	L I	1 st -2 nd century	
Pl. 18: 3	N-92-3	I.3017	Spout and container shard with a volute / red slip	1	L I, III, IV	1 st -2 nd century	
Pl. 18: 4	N-117-26	I.2	Spout shard on the joint with the shoulder	1	L I	1 st -2 nd century	
Pl. 18: 5	N-117-25	I.2	Base shard of an oil lamp	1	Volute-lamp?	1 st -2 nd century	
Pl. 18: 6	N-138-7	I.2121	Handle shard	1	L. II, IV, V, VII, VIII	1 st -3 rd century	
Pl. 18: 7	08 NA-4-1	I.2001	Shoulder shard	1	<i>Firmalampen</i>	1 st -3 rd century	
Pl. 18: 8	08 NA-5-35	I.2002	Shoulder shard	1	<i>Firmalampen</i>	1 st -3 rd century	
Pl. 18: 9	08 NA-5-36	I.2002	Shoulder shard with a rivet	6	<i>Firmalampen</i>	1 st -3 rd century	
Pl. 18: 10	08 NA-5-6	I. 2002	Shoulder shard	1	<i>Firmalampen</i>	1 st -3 rd century	
Pl. 18: 11	N-138-6	I.2121	Shard of disc and shoulder with a rivet	1	<i>Firmalampen</i>	1 st -3 rd century	
Pl. 18: 12	08 NA-6-2	Surface find next to the southern wall	Spout shard	1	<i>Firmalampen?</i>	1 st -3 rd century	
Pl. 18: 13	N-14-4	I.3006	Oil-lamp handle shard	1	Atlante VIII	From 5 th century	Bonifay 2004: 358-370
Fig. 1: 1	N-108-1	I.2101	Shards of disc, shoulder and base / depiction of a dog running left	8	L IB/IIIa		Bailey 1980: Q821
Fig. 1: 2	N-109-1	I.2101	Disc shard with a depiction of a recumbent he-goat	2	L I- IV?		DFB III.a.13.4, VB t. VI, 5
Fig. 1: 311	N-92-4	I.3017	Decorated disc fragment / depiction of a gladiator/boxer	1	L I- IV?		
/	N-101-14	I.2101	Container shard / dark brown-black slip	1	L I- IV?		
/	N-53-9	I.3014	Shoulder shard	1	L I- IV?		
/	N-92-1	I.3017	Oil-lamp container shard / red slip	1			
TOTAL NUMBER OF SHARDS:						68	

Tab. 22 Ceramic oil lamps (abbreviation DBF refers to the typology by Di Filippo Balestrazzi 1988, abbreviation L is for the Loeschke 1919) typology

prilog identifikaciji s tipom Atlante VIII (Pavolini 1985: 192–194) kojeg Bonifay datira od kraja 4. do početka 6. stoljeća, no s obzirom na to da je drška N-14-4 puna, njezina bi datacija mogla biti od prve polovine 5. stoljeća (Bonifay 2004: 358–370).

Svi navedeni tipovi uljanica izrazito su česti na kvarnerskim lokalitetima, s iznimkom onih kasnoantičkih (Ožanić Roguljić, Konestra 2012), i dok većina ukrasa na volutnim uljanicama nalazi analogije u Akvileji (gdje je pretpostavljena njihova proizvodnja), ipak nam vrlo fragmentarno stanje ulomaka onemogućava dodatne zaključke. Indikativno je, međutim, kako većinu ulomaka lampica možemo datirati kroz 1. i 2. stoljeće kada je očito njihovo korištenje na forumu bilo najbrojnije.

Novovjekovna keramika (T. 19, sl. 2, tab. 23)

Nekoliko keramičkih nalaza pripada ulomcima novovjekovnih keramičkih vrsta majolici (sl. 2), glaziranoj keramici i



Sl. 2 Novovjekovna keramika – 1. N-98-24-1, 2. N-98-24-1, 3. N-123-2 (fotografije: A. Konestra)

Fig. 2 Modern period pottery – 1. N-98-24-1, 2. N-98-24-1, 3. N-123-2 (photos by A. Konestra)

terraglia. Ulomak N-98-24-1 (sl. 2: 1) pripada majolici, i to vrču podrijetlom iz Veneta, koji nalazi vrlo preciznu analogiju s vrčem iz ulice Porta Stovagnaga u Puli, gdje je datiran od kraj 18. i u 19. stoljeća (Bradara 2006: 167, T. II: 19, sl. 9) te s ulomkom iz uvale Veštar kod Rovinja (Višnjic 2011: 24, cat. 1425; Pešić 2011: 65, br. 51). Ulomak N-98-24-2 (sl. 2: 2) pripada istoj keramičkoj vrsti, no vjerojatno zdjelici ili tanjuru. Slične je datacije i N-148-1 (T. 19: 1) koji vjerojatno pripada kuhinjskoj keramici *inverciata – slip ware* i to vjerojatno zatvorenoj posudi manjih dimenzija (Bradara 2006: 158–159). Ulomak ruba zdjelice N-131-42 (T. 19: 2) pripada smeđe glaziranoj keramici s mrljama (*inverciata marrone a macchie*) (Pannuzzi 2011: 457), koja datira u 18. i 19. stoljeće. Ulomci stijenke N-101-11 (T. 19: 4) i N-123-2 (sl. 2: 3) pripadaju keramici *terraglia* koja se proizvodila od polovine 18. stoljeća,

visible inclusions (calcite?).

Only one handle shard (N-14-4, Pl. 18: 13) belongs to late antique “African” oil lamps. Its features speak in favour of the identification with type Atlante VIII (Pavolini 1985: 192–194), which Bonifay dated from the end of the 4th until the beginning of the 6th cent., however, considering that handle N-14-4 is solid, it might be dated from the first half of the 5th cent. (Bonifay 2004: 358–370).

All the mentioned types of oil lamps are extremely common at sites in the Kvarner Gulf, with the exception of the late antique ones (Ožanić Roguljić, Konestra 2012). While most decorations on volute-lamps have analogies in Aquileia (where they were presumably made), the fragmentary condition of the shards nevertheless impedes us from reaching additional conclusions. Indicatively, however, most lamp shards may be dated through the 1st and 2nd cent., which was obviously the peak of their use at the forum.

Modern period pottery (Pl. 19, Fig. 2, Tab. 23)

Several ceramic finds belong to shards of modern-period ceramic types: maiolica (Fig. 2), glazed pottery and *terraglia*. Shard N-98-24-1 (Fig. 2: 1) belongs to maiolica, more precisely to a jug originating from Veneto, which has a very precise analogy in a jug from Porta Stovagnana Street in Pula, where it was dated from the end of the 18th c. and in the 19th cent. (Bradara 2006: 167, T. II: 19, sl. 9) as well as in a shard from the Veštar cove near Rovinj (Višnjic 2011: 24, cat. 1425; Pešić 2011: 65, no. 51). Shard N-98-24-2 (Fig. 2: 2) belongs to the same ceramic type, although probably to a small bowl or plate. Shard N-148-1 (Pl. 19: 1) is similarly dated. It probably belongs to *inverciata – slip ware* cooking ware, most likely to a small-sized restricted-mouth vessel (Bradara 2006: 158–159). Rim shard of a small bowl N-131-42 (Pl. 19: 2) belongs to brown-glazed ware with spots (*inverciata marrone a macchie*) (Pannuzzi 2011: 457), dated to the 18th and 19th cent.. Wall fragments N-101-11 (Pl. 19: 4) and N-123-2 (Fig. 2: 3) belong to *terraglia* ware, which was produced from the mid-18th cent. and whose bright ceramic fabric had a transparent glazed slip, while N-123-2 (Fig. 2: 3) had impressed decoration in the decalcomania technique (transferred printing) on either side (Bradara 2006: 160–161). Based on the decoration colour we can date this shard from the end of the 18th cent. until the mid-19th cent. (Samford 1997: 20). Specimens of the latter ceramic type, connected with production centres in Northern Europe, were found in the Kvarner Gulf near the islands of Sveti Petar and Ilovik (Bezák 2014: 32, Fig. 28). Base N13-A1-16 (Pl. 19: 3), whose interior exhibits traces of yellowish glaze, can also be attributed to a type of glazed pottery, while plate rim N13-A1-19¹⁴ belongs to porcelain ware and can probably be dated to the 20th cent., which makes it the most recent find from the forum.

Fishing net weights (Pl. 19, Tab. 24)

Fragments of ceramic spindle-whorls N07-A1-5 (Pl. 19: 5) and N08-A6-9 (Pl. 19: 6) were interpreted as fishing-net weights of type CII1 after the typology by D. Bernal Casasola (Bernal Casasola 2010: 97, 98–101, Fig. 9), and they are very

¹⁴ The object was not drawn due to its small dimensions.

Crtež	Br. n.	SJ	Oblik / Vrsta ili Struktura	Datacija	Analogija
Sl. 2: 1	N-98-24-1	I.2101	Stijenka vrča / Majolika, oslikani okvir unutar kojeg su cvjetni elementi (plava, smeđa i žuta)	Kraj 18. – 19. st.	Bradara 2006: sl. 9
Sl. 2: 2	N-98-24-2	I.2101	Stijenka posude / Majolika s ukrasom (plava)	Kraj 18. – 19. st.?	
T. 19: 1	N-148-1	I.2127	Dno posude / Boja: 5Yr 5/8; Primjese: rijetke sitne crne i sjajne; Premaz: prozirni	18.–19. st.	
T. 19: 2	N-131-42	I.4000	Ulomak ruba / <i>Invetriata marrone a macchie</i> / Mrljasti tamno- i svijetlosmeđi premaz		
T. 19: 3	N13-A1-16	I.2100; I.2101; I.2103;	Ulomak dna / Boja: 5yr/8/3; Premaz: žućkasta glazura na unutarnjoj površini		
T. 19: 4	N-101-11	I.2101	Stijenka posude / <i>Terraglia</i>	Od polovine 18. st.	
Sl. 2: 3	N-123-2	I.2115	Stijenka posude / <i>Terraglia</i> s dekalkomacijom u crnom tonu	Od polovine 18. st.	
/	N13-A1-19	I.2100; I.2101; I.2103;	Ulomak ruba tanjura / porculan	20. st.	
Drawing	No. f.	SU	Form / Type or Fabric	Date	Analogy
Fig. 2: 1	N-98-24-1	I.2101	Jug wall / Maiolica, painted frame filled with floral elements (blue, brown and yellow)	End of 18 th -19 th century	Bradara 2006: Fig. 9
Fig. 2: 2	N-98-24-2	I.2101	Vessel wall / Maiolica with decoration (blue)	End of 18 th -19 th century?	
Pl. 19: 1	N-148-1	I.2127	Vessel base / Colour: 5Yr 5/8; Inclusions: rare small black and glossy; Slip: transparent	18 th -19 th century	
Pl. 19: 2	N-131-42	I.4000	Rim shard / <i>Invetriata marrone a macchie</i> / Spotty dark and light brown slip		
Pl. 19: 3	N13-A1-16	I.2100; I.2101; I.2103;	Base shard / Colour: 5yr/8/3; Slip: yellowish glaze on the interior surface		
Pl. 19: 4	N-101-11	I.2101	Vessel wall / <i>Terraglia</i>	From mid-18 th century	
Fig. 2: 3	N-123-2	I.2115	Vessel wall / <i>Terraglia</i> with decalcomania in black tone	From mid-18 th century	
/	N13-A1-19	I.2100; I.2101; I.2103;	Plate rim shard / porcelain	20 th century	

Tab. 23 Novovjekovna keramika

Tab. 23 Modern period pottery

Crtež	Br. n.	SJ	Tip	Datacija	Analogija
T. 19: 5	N07- A1 -5	Površinski nalaz uz južne stube	CII1	2./1. st. pr. Kr. – 6./7. st. po. Kr.	Bernal Casasola 2010: 100–101
T. 19: 6	N08 - A6 -9	Površinski nalaz uz južni zid	CII1	2./1. st. pr. Kr. – 6./7. st. po. Kr.	Bernal Casasola 2010: 100–101
Drawing	No. f.	SU	Type	Date	Analogy
Pl. 19: 5	N07- A1 -5	Surface find next to southern staircase	CII1	2 nd /1 st century BC – 6 th /7 th century AD	Bernal Casasola 2010: 100–101
Pl. 19: 6	N08 - A6 -9	Surface find next to southern wall	CII1	2 nd /1 st century BC – 6 th /7 th century AD	Bernal Casasola 2010: 100–101

Tab. 24 Utezi za mrežu

Tab. 24 Fishing net weights

a čija je svijetla keramička struktura presvučena prozirnom glazurom, dok je u slučaju N-123-2 (sl. 2: 3) s obje strane prisutan otisnuti ukras u tehnici dekalkomanija (transferni tisak) (Bradara 2006: 160–161). Prema boji ukrasa ovaj ulomak možemo datirati od kraja 18. do polovine 19. stoljeća (Sam-

common at coastal and underwater sites. According to the mentioned typology, which is mostly founded on Hispanian sites, these objects are dated extremely wide, i.e. from the 2nd cent. BC until the 7th cent. AD, and they were presumably used with medium- and large-sized nets (Bernal

Crtež	Br. n.	SJ	Tip	Datacija	Analogija
T. 19: 7	N08-A1-7	I.2003	Tegula s pečatom	August – Vespazijan	Matijašić 2009: A1, A10
Drawing	No. F.	SI	Type	Date	Analogy
Pl. 19: 7	N08-A1-7	I.2003	Tegula with a stamp	Augustus-Vespasian	Matijašić 2009: A1, A10

Tab. 25 Građevinska keramika

Tab. 25 Construction ceramics

ford 1997: 20). Primjerci potonje keramičke vrste, povezane s proizvodnim središtima sjeverne Europe, na Kvarneru su pronađeni uz otoke Sveti Petar i Ilovik (Bezjak 2014: 32, sl. 28). Nekoju vrstu glazirane keramike pripada i dno N13-A1-16 (T. 19: 3), na čijoj su unutarnjoj strani vidljivi tragovi žućkaste glazure, dok rub tanjura N13-A1-19¹⁴ pripada porculanskom posuđu, te vjerojatno datira u 20. stoljeće, što ga čini najrecentnijim nalazom na forumu.

Utezi za mreže (T. 19, tab. 24)

Ulomci keramičkih pršljenova N07-A1-5 (T. 19: 5) i N08-A6-9 (T. 19: 6) interpretirani su kao utezi za mreže tip CII1 prema tipologiji D. Bernala Casasole (Bernal Casasola 2010: 97, 98–101, Fig. 9), a vrlo su česti nalaz na primorskim i podmorskim lokalitetima. Prema navedenoj tipologiji koja se oslanja na hispanske lokalitete, datacija ovih predmeta izrazito je široka, odnosno od 2. st. pr. Kr. sve do 7. stoljeća, a pretpostavlja se njihovo korištenje s mrežama srednjih i velikih dimenzija (Bernal Casasola 2010: 101).

Građevinska keramika (T. 19, tab. 25)

Unutar građevinske keramike koja je pregledana uočeni su imbreksi, tegule, podne pločice (*spicae*) te jedan ulomak tegule s pečatom radionice Pansiana – N08-A1-7 (T. 19: 7). Nažalost, sačuvana su tek tri slova (SIA) koja nam ne daju elemente za sigurnu definiciju tipa pečata (ligature i sl.), no slova su pravilno oblikovana, postavljena vrlo blizu i na rubovima proširena, dok je sam pečat pravilno otisnut s relativno dubokim reljefom. Vrlo slična kartuša nalazi se na pečatima A1 i A10 s Bribira (Matijašić 2009: 2–3, A 1, 4–5, A10). Za pečat s *Fulfinuma* isključili bismo pripadnost varijanti Vibi Pansa, ali zbog nedostatka elemenata za preciznu dataciju moramo pretpostaviti dataciju kroz cijelo razdoblje trajanja radionice nakon carskog preuzimanja, dakle od Augusta do Vespazijana (Matijašić 1983: 985), iako bismo se, zbog nedostatka ligatura unutar sačuvanog teksta, opredijelili za nešto raniju dataciju gdje su takve varijante češće.

ZAKLJUČAK

Tijekom obrade materijala s istraživanja katalogizirano je 736 ulomka keramike različitih vrsta te je ustanovljen procijenjeni broj posuda koji iznosi 185 posuda (odnosno predmeta koji uključuju i utege te tegulu s pečatom), razvrstane unutar 17 kategorija (graf. 5). Iako su slojevi iz kojih materijal potječe, kako je već rečeno, uglavnom poremećeni, ipak je u pojedinim situacijama na osnovi keramičkog materijala bilo moguće pobliže datirati pojedine slojeve te tako potvrditi datacije i faze koje su bile uočene analizom stratigrafske situacije. U grafikonu 6 donosimo okvirne datacije slojeva

Casasola 2010: 101).

Construction ceramics (Pl. 19, Tab. 25)

The analysed assemblage of construction ceramics includes imbrices, tegulae, floor tiles (*spicae*) and a fragment of a tegula with a stamp of the Pansiana workshop – N08-A1-7 (Pl. 19: 7). Unfortunately, only three letters (SIA) are preserved, which does not give us enough elements to securely define the type of the stamp (ligatures etc.). Still, the letters are regularly shaped, set close to one another and widened at the edge, while the stamp itself is regularly impressed with a relatively deep relief. A very similar cartouche is found on stamps A1 and A10 from Bribir (Matijašić 2009: 2–3, A 1, 4–5, A10). For the stamp from *Fulfinum* we would exclude the attribution to the Vibi Pansa variant, although due to the lack of elements for a precise dating we ought to presume a dating throughout the entire period of duration of the workshop following the imperial takeover, i.e. from Augustus to Vespasian (Matijašić 1983: 985), even though due to the absence of ligatures within the preserved text we would be inclined to support a somewhat earlier date, when such variants are more common.

CONCLUSION

During the processing of the material from the excavations a total of 736 ceramic shards of various types were catalogued, and the number of vessels (or more precisely, objects, which includes also the weights and the tegula with a stamp) was estimated at 185, divided into 17 categories (graph 5). As already said, even though the layers from which the material came were by and large disturbed, in certain situations it was possible to closely date certain layers based on the ceramic material, and to corroborate in this way datings and phases observed in the analysis of the stratigraphy. In graph 6 we put forward the approximate dates of layers on the basis of the analysed ceramic assemblage, while an extensive interpretation of the stratigraphy and phases of the site was given in Čaušević-Bully, Valent 2015: 126–139. As a closed context we single out layer I.3019, which is located in the area between the basilica and the temple and pertains to the backfill of the canal negated by the construction of the latter, whose date is generally associated with the 1st cent. (Italic amphorae, ITS, a volute-lamp), thus defining the time of the 1st and 2nd construction phases of the forum, while the other layers in this area point to building activities in the later phases (e.g. SJ I.3003, I.3008). The material from layers I.2115 and I.2123, again limited exclusively to the 1st cent., points on the other hand to the 1st building phase within sector I.2.

The majority of ceramic types are represented by only a few recognizable forms which, even if not statistically in-

14 Predmet nije nacrtan zbog malih dimenzija.

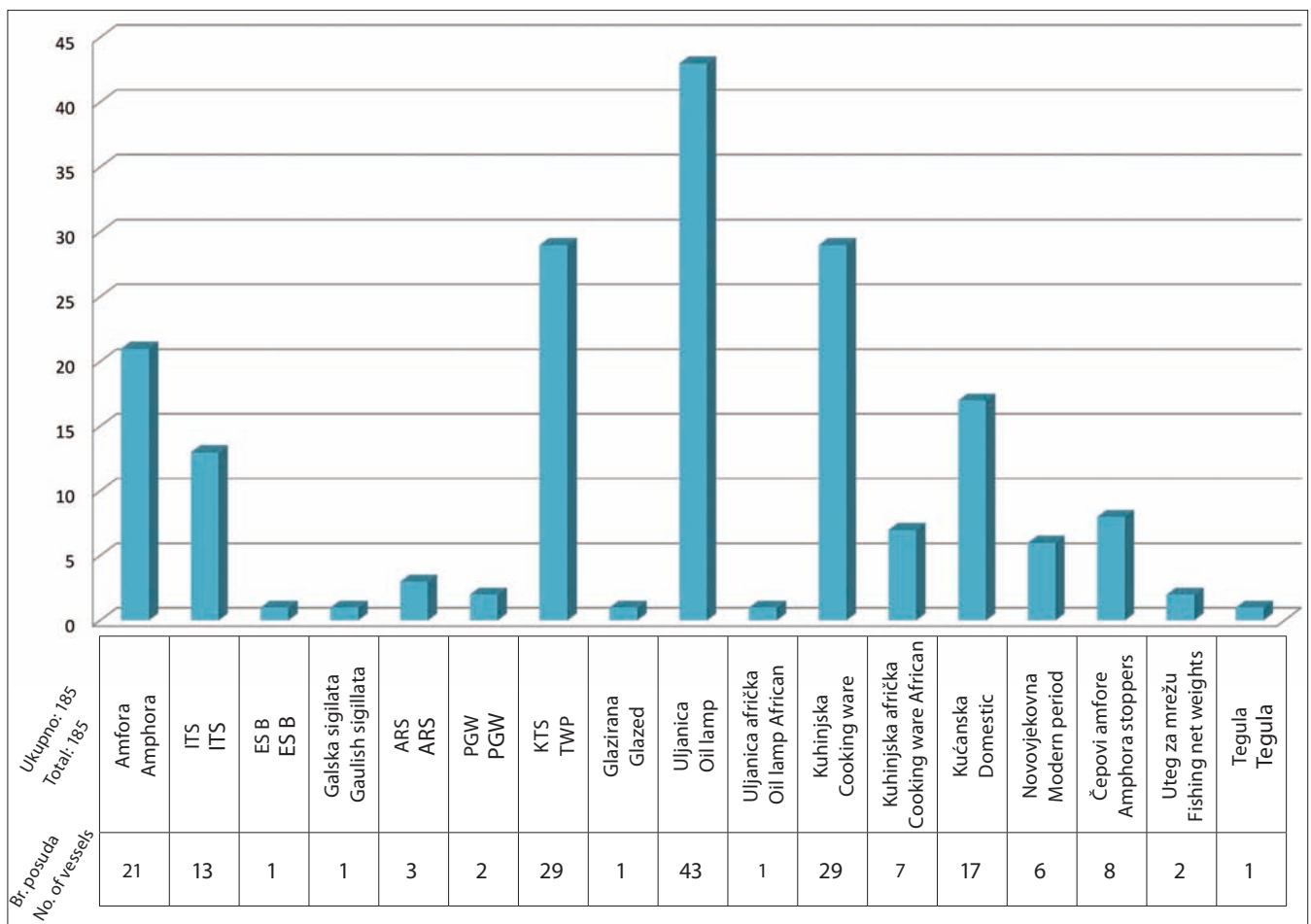

Graf. 5 Ukupni procijenjeni broj posuda prema vrsti
Graph 5 Total estimated number of vessels by type

prema obrađenoj keramičkoj građi, dok je opsežna interpretacija stratigrafije i faza lokaliteta u Čaušević-Bully, Valent 2015: 126-139. Kao zatvorenu cjelinu ističemo sloj I.3019 koji se smješta na područje između bazilike i hrama, a odnosi se na zapunu kanala koji je negiran gradnjom potonjeg, čija se datacija uglavnom veže uz 1. stoljeće (italske amfore, ITS, volutna uljanica), te tako definira vrijeme 1. i 2. graditeljske faze foruma, dok drugi slojevi na ovom području upućuju na graditeljske aktivnosti kasnijih faza (npr. SJ I.3003, I.3008). Materijal iz slojeva I.2115 i I.2123, ponovno ograničen isključivo na 1. stoljeće, upućuje pak na 1. graditeljsku fazu unutar sektora I.2.

Većina keramičkih vrsta zastupljena je s tek nekoliko prepoznatljivih oblika koji, ako i nisu statistički indikativni, ipak pokazuju raznovrsnost keramike koja je cirkulirala na području *Fulfinuma*, ali i Kvarnera, kroz antiku i kasnu antiku. U ponekim slučajevima (npr. ES B i galska sigilata), primjerci s *Fulfinuma* obogaćuju saznanja o regionalnoj distribuciji ovih vrsta, upotpunjujući poznate podatke (za ES B vidi Maggi 2006). Iako je teško materijal razvrstati prema dataciji, poglavito jer većina oblika ima dulji vijek trajanja, ipak možemo primijetiti nekoliko razlika u vrsti keramičkog materijala koji je prisutan u ranijim razdobljima od onoga koji je prisutan u onim kasnijim. U tu svrhu možemo upotrijebiti primjere dobro definiranih vrsta, gdje su i ulomci stijenki i

dicative, nevertheless exhibit a variety of ceramics circulating in the area of *Fulfinum*, as well as in the Kvarner Gulf, through antiquity and late antiquity. In certain cases (e.g. ES B and Gaulish sigillata), specimens from *Fulfinum* enrich our knowledge on the regional distribution of these types, complementing the known data (for ES B see Maggi 2006). Even though it is difficult to classify the material by date, all the more so as most forms have a long duration, we can still distinguish several differences in the type of ceramic material present in earlier periods from the one present in the later ones. For this purpose we can use the examples of well-defined types, where both wall and base shards are easily identifiable:

1. The first such example is fine tableware, which, as can be seen in graph 2, was the most common throughout the 1st and 2nd cent., a period in which we situate ITS and TWP, ES B, Central Gaulish sigillata, glazed pottery, PGW and the earliest ARS. Only two ARS D shards date from the later periods, even though it was imported in the Kvarner Gulf until the 7th cent. (Makjanić 1983: 52).

2. The second example speaking about the different ratios between individual types through different phases of use of the forum area pertains to oil lamps. An extremely high number of lamp shards (as well as the presumed number of vessels) dated to the 1st and 2nd cent. stands in stark

SJ	1.	2.	3.	4.	5.	6.	7.	SV	NV	R
2101										
2115										
2121										
2123										
2127										
3012										
3014										
3017										
4000										
3001										
3002										
3003										
3006										
3008										
3010										
3019										
2003										
2011										
2013										
2001										
2002										
2103										

Graf. 6 Predložene datacije slojeva prema utvrđenoj keramičkoj građi, po stoljećima i kasnijim razdobljima (SV = srednji vijek, NV = novi vijek, R = recentno)

Graph 6 Proposed dates of layers based on the determined ceramic material, by cent. and later periods (MA = Middle Ages, MP = Modern period, R = Recent period)

dna s lakoćom odrediti:

1. Prvi takav primjer jest fino stolno posuđe koje je, kako je vidljivo iz grafikona 2, najbrojnije kroz 1. i 2. stoljeće kada smještamo ITS i KTS, te ES B, srednjogalsku sigilatu, glaziranu keramiku, PGW i najraniju ARS. Kroz kasnija razdoblja prisutna su tek dva ulomka ARS D, iako je na Kvarneru njezin import rasprostranjen sve do 7. stoljeća (Makjanić 1983: 52).

2. Drugi je primjer koji govori o različitim omjerima pojedinih vrsta kroz faze korištenja prostora foruma onaj uljanica. Izrazito velik broj ulomaka lampica (ali i pretpostavljeni broj posuda) koje datiraju u 1. i 2. stoljeće sasvim je suprotan kasnoantičkoj situaciji, kada je prisutan tek jedan ulomak lampice (graf. 4). Ako prihvatimo simboličku ulogu uljanice/svjetiljke, tada bismo ovaj trend mogli povezati uz kultnu funkciju forumskog hrama (Topić 2003: 193) koja se kroz kasnija stoljeća vjerojatno gubi, na što upućuju i brojne arhitektonske preinake ovog prostora (Čaušević-Bully, Valent 2015: 126-139). No valja istaknuti da je sličan nerazmjer u količini rano- i kasnoantičkih uljanica registriran za šire kvarnersko područje, osim za Tarsatiku (Ožanić Roguljić, Konestra 2012).

3. Treći primjer koji govori o određenim promjenama u namjeni prostora ili promjeni navika/potreba stanovnika kasnoantičkog *Fulfinuma*, jest nedostatak kućanskog posuđa iz kasnijih stoljeća – vrčeva, lonaca za čuvanje namirnica i sličnih posuda – a koje se javljaju kroz ranija stoljeća. Može-

contrast to the situation from late antiquity, which is represented with only a single lamp shard (graph 4). If we accept the symbolical role of oil lamps, we may associate this trend with the cult function of the forum temple (Topić 2003: 193), which was probably lost in the subsequent cent., as suggested by the frequent architectural modifications of this space (Čaušević-Bully, Valent 2015: 126-139). However, it should be stressed that a similar imbalance exists in the quantity of early and late antique oil lamps in the wider Kvarner area, except in the case of Tarsatica (Ožanić Roguljić, Konestra 2012).

3. The third example that tells about certain changes in the function of the space, or the change in habits/needs of the residents of late antique *Fulfinum*, is the absence of cooking ware from later cent. – jugs, storage pots and similar vessels – which had been present in the earlier cent.. We may presume that the role of storage pots was now taken by amphorae, cooking jars or pots made of perishable materials (baskets, barrels etc.).

Minor differences in the concentration of specific types are noted also among cooking ware and amphorae, allowing us to state that earlier amphorae are somewhat less common than the latter types, however, within these categories there is a large number of indeterminate walls and bases, which raises doubts as to the accuracy of statistical conclusions.

mo pretpostaviti da su funkciju čuvanja namirnica preuzele amfore, kuhinjski lonci ili pak posude od drugih materijala koje nam se nisu sačuvala (košare, bačve i sl.).

Manje se razlike u koncentraciji pojedinih vrsta primjećuju i u kuhinjskom posuđu i amforama, pa možemo reći da su ranije amfore nešto rjeđe od kasnijih, no u ovim je kategorijama velik broj stijenki i dna ostao neodređen, što dovodi u pitanje točnost statističkih zaključaka.

Analizom materijala primijećena je još jedna razlika između ranijih i kasnijih razdoblja, a to je provenijencija materijala koja, kako ćemo vidjeti, u potpunosti prati tendencije onodobnoga trgovačkog prometa. Kroz prva dva stoljeća života na forumu prisutna je izrazito velika količina importiranoga finog stolnog posuđa i lampica, ali su prisutni i importi kuhinjskog posuđa, svi mahom iz Italije. Ovdje posebno ističemo *orlo bifido* tavu podrijetlom iz Kampanije i pripadne poklopce, italsku *terru sigillatu* i keramiku tankih stijenki. Uz importirani materijal vidljiva je prisutnost lokalnih/regionalnih proizvoda koje barem dijelom možemo pripisati crikveničkoj radionici, ili pak nekoj od potvrđenih ili pretpostavljenih dalmatinskih radionica nastalih u rimskom razdoblju *ex novo* ili na helenističkoj keramičarskoj tradiciji (npr. Katić 1999/2000; Šešelj 2005: 51; Pedišić, Podrug 2007: 100–106; Miše, Čargo 2010: 12–14, 20, 25 i dr.; Brajković 2011; Lipovac Vrkljan 2011: 4, bilj. 5; Oštarić, Kurilić 2013: 274; Pesavento Mattioli 2014: 194–195). Ista je situacija uočena i unutar grobnih priloga fulfinske nekropole Kurilovo (Dautova Ruševljan 1973; Konestra 2014).

Već krajem 1. stoljeća pojavljuju se na forumu prvi importi iz drugih krajeva carstva – istočni Mediteran, Galija, možda sjeverna Afrika (N-143-2). Od kraja 2. stoljeća situacija se drastično mijenja i nestaje lokalni materijal, a počinje pojava afričkoga kuhinjskog i stolnog posuđa (te možda kuhinjskog posuđa s istočnog Mediterana), koju prati masivniji uvoz proizvoda skladištenih u amforama. U tom kontekstu valja sagledati i nedostatak afričkog posuđa unutar dosad istraženih grobnih priloga nekropole Kurilovo, što bi moglo pomoći u definiciji kraja 2. stoljeća kao *terminus ante quem* za kraj pokapanja na nekropoli.¹⁵ Od ovog trenutka registri- raju se i importi s panonskog područja (PGW).

U kasnoj antici bilježi se pojava crne grube kuhinjske keramike s izrazitom koncentracijom primjesa i čestim urezanim ili metličastim ukrasima, kakva karakterizirana jadranski, posebno gornjojadranski prostor, Sloveniju i alpsko područje. Nedovoljna istraženost ovog materijala na Kvarneru onemogućava njegovo smještanje unutar lokalnih, regionalnih ili nadregionalnih produkcija, no valja uzeti u obzir mogućnost importiranja barem dijela ovoga materijala, što bi značilo povratak regionalnoj proizvodnji i razmjeni (gornjo)jadranskog prostora gdje su dosad, na osnovi arheometrijskih analiza, identificirane različite grupe sličnih proizvoda (Gelichi 1998: 483). Iako nedovoljno obrađeno, ovo je posuđe na Kvarneru izrazito brojno i predstavlja svojevrсни marker za kasnija stoljeća (Starac, R. 1999; 2004; Bekić 2009).

The analysis of the assemblage revealed another difference between earlier and later periods, namely the provenance of the material, which, as we shall see, completely follows the tendencies of the commercial traffic of the time. Through the first two cent. of life at the forum the quantity of imported fine tableware and lamps is extremely high, however, imports of cooking ware are also present, which all by and large came from Italy. Here we particularly single out an *orlo bifido* pan originating from Campania, together with corresponding lids, Italic *terra sigillata* and thin-walled pottery. In addition to imports, local/regional products are also present, at least a part of which may be attributed to the Crikvenica workshop or to some of confirmed or presumed Dalmatian workshops established either *ex novo* in the Roman period or based on the Hellenistic ceramic tradition (e.g. Katić 1999/2000; Šešelj 2005: 51; Pedišić, Podrug 2007: 100–106; Miše, Čargo 2010: 12–14, 20, 25 etc.; Brajković 2011; Lipovac Vrkljan 2011: 4, note 5; Oštarić, Kurilić 2013: 274; Pesavento Mattioli 2014: 194–195). An identical situation was observed with the grave goods at the Kurilovo necropolis in Fulfinum (Dautova Ruševljan 1973; Konestra 2014).

The first imports from other parts of the Empire—Eastern Mediterranean, Gaul, perhaps North Africa—appear at the forum as early as the end of the 1st cent. (N-143-2). From the end of the 2nd cent. the situation changed drastically, with the disappearance of local material and the appearance of African cooking ware and tableware (and perhaps also cooking ware from the Eastern Mediterranean), which follow a more massive import of products stored in amphorae. In this context we also ought to consider the lack of African pottery within the so far excavated grave goods at the Kurilovo necropolis, which might help in defining the end of the 2nd cent. as *terminus ante quem* for the end of burials at the necropolis.¹⁵ This moment also marks the beginning of imports from Pannonia (PGW).

The appearance of black coarse cooking ware with a pronounced concentration of inclusions, frequently featuring incised or brushed decoration, which is typical for the Adriatic—particularly the Upper Adriatic—area, Slovenia and the Alpine region, dates to late antiquity. The insufficient level of research on this material in the Kvarner area prevents us to situate it within local, regional or supregional productions, although we should take into consideration the possibility of import of at least a part of this material, which would entail a return to regional production and exchange in the (Upper) Adriatic region, where so far, based on archaeometric analyses, different groups of similar products have been identified (Gelichi 1998: 483). As understudied as it may be, this pottery type is extremely abundant in the Kvarner area, and stands as a marker of sorts for subsequent cent. (Starac, R. 1999; 2004; Bekić 2009). However, this does not entail a corresponding end of the trade in goods transported in African and Eastern Mediterranean amphorae, whose presence in *Fulfinum* endured until the 7th cent.. An interesting analogy is found at the principia in

¹⁵ Iako je nekropola dijelom nestručno istraživana, glavnina materijala je objavljena (za potrebe ovog rada autorica je taj materijal ponovno pregledala, kao i materijal s novijih istraživanja) (Dautova Ruševljan 1973; Konestra 2014).

¹⁵ In spite of the partly inexpert excavation methodology, the bulk of the material from the necropolis has been published (for the purpose of this paper the author has reexamined the assemblage, as well as the material from the recent excavations) (Dautova Ruševljan 1973; Konestra 2014)

STRUK-TURA	PRIMJERCI	OPIS	BR. DIJAG. UL.	UKRAS
1	2007 NA-1-7; N-55-3; 2008 NA-5-45; N-13129; N-131-46	Gruba narančasta keramika s premazom koji varira od oker do crne boje. Na nekim je ulomcima prisutan metličasti ukras (vertikalno, horizontalno i možda valovito urezane guste pruge). PRIMJESE: česte sitne bijele i sjajne, česte srednje bijele i sjajne; BOJA: 2,5YR 4/4, 3/4, 3/6; unutarnja i vanjska površina: 2.5YR 3/1	3	Tip 2
2	N-16-10; N-5-11; N-14-1; 08-NA-5-19E;	Gruba narančasta keramika s premazom koji varira od smeđe do crne boje. Na nekim je ulomcima prisutan metličasti i valoviti ukras. PRIMJESE: sitne i srednje česte bijele, povremene sitne sjajne, rijetke srednje crvene; BOJA: 2.5YR 3/2, 3/4, 4/6; površina: GLEY 22.5/5PB, 2.5YR 2.5/1, 10YR 4/2	3	Tip 1
3	N-5-9; 08NA-5-19D;	Gruba narančasto-smeđa keramika, ponekad zaglađena površina. PRIMJESE: česte sitne i srednje bijele i sjajne; BOJA: 2.5YR 4/6, 2.5/2	1	
4	N-14-8A; N-117-15A	Gruba keramika crna u presjeku i unutrašnjosti, crvena i zaglađena vanjska površina. PRIMJESE: česte velike, srednje i sitne bijele; BOJA: vanjska površina 2.5YR 4/6; unutarnja površina i presjek 2.5YR 3/1	1	
5	N-55-2; 13 NA1-2: N-801	Gruba keramika boje koja varira od oker, narančaste do crnosmeđe (na površini). Iako je površina zaglađena, hrapava je i na njoj su vidljive nepravilno izbočene primjese. Premaz jednog ulomka je ispucan. PRIMJESE: česte srednje bijele i sjajne, povremene velike crne izdužene i kružne svjetlucave, česte sitne sjajne i crne. Tragovi biljnih primjesa? BOJA: vanjska površina 10R 2.5/1, unutarnja površina 10R 5/6	3	Tip 1, Tip 3
6	N-101-9; N-9-2	Crna gruba keramika s lagano zaglađenom površinom, posebno unutar-njom. PRIMJESE: česte bijele raznih dimenzija, česte sitne sjajne, povremene srednje sjajne; BOJA: GLEY 1 2.5/N	2	
7	08 NA-5-25; 08 NA-5-19B; N-131-28; 2008 NA-1-5; N-117-17; N-67-2	Crno-smeđa gruba keramika sa zaglađenom površinom koja je ipak hrapava na dodir. PRIMJESE: česte sitne sjajne, česte sitne bijele, vrlo česte prozirnobijele četverokutne raznih dimenzija. BOJA: 7.5YR 2.5/1	3	Tip 1
8	N-14-2	Crno-smeđa gruba keramika sa zaglađenom površinom koja je glatka na dodir. PRIMJESE: česte sitne bijele i sjajne, česte velike bijele i sjajne, česte srednje tamne svjetlucave; BOJA: 7.5 YR 3/1; "sendvič" pečeno	1	
9	N-14-3; 08 NA-5-19C	Siva gruba keramika bez tragova zaglađivanja na površini. PRIMJESE: česte sitne i srednje sjajne, povremene srednje bijele; BOJA: 7.5YR 2.5/1	1	Tip 1
10	N-1-6	Sivo-crna gruba keramika sa sitnim primjesama. Hrapava na dodir. PRIMJESE: česte sitne sjajne i bijele, srednje bijele, na površini rijetke velike bijele i prozirne; BOJA: 5YR 2.5/1	2	
11	N-98-19	Sivo-crna gruba keramika, vanjska je površina zaglađena i vidljiv je trag premaza (glazura?). PRIMJESE: česte sitne bijele i sjajne, povremene srednje i velike bijele, rijetke velike tamnosive; BOJA: 2.5YR	2	
12	08 NA-5-24; 08 NA-5-20; 08 NA-5-19-F; 08 NA-521; N-14-8B; N-117-16	Smeđenarančasta gruba keramika s uglavnom manjim primjesama, izvana crna/zacrnjena (gorena?). Mogući tragovi premaza. PRIMJESE: česte sitne i srednje bijele, povremene velike bijele i prozirne, povremene crne sjajne raznih dimenzija; izvana sjajne; unutar presjeka ulomka 521 vidljive sitne sjajne zlatne primjese; BOJA: 5YR 2.5/1, 5YR 4/6	4	
13	N-14-8C	Pročišćenija keramika oker bojegorena. PRIMJESE: česte sitne crne, sjajne i crvene primjese. Rijetke velike bijelosjajne i crvene. BOJA: 5YR 5/6; 5YR 2.5/1;	1	
14	08 NA-5-19; N-23-1; N16-8	Narančasta gruba keramika. PRIMJESE: česte sitne sjajne, česte srednje sjajne, česte bijele sjajne srednje i velike; BOJA: 10r 4/8, 7.5YR 2.5/1	1 +1 posuda	
15	2008 NA-5-32; N-117-15B; N-98-18	Oker-smeđa gruba keramika, hrapava po površini. PRIMJESE: česte sitne sjajne, česte srednje sjajne, povremene srednje bijele, povremene sitne crne; BOJA: 5YR 5/6;	1	
16	N-101-8	Sivo-smeđa keramika, zaglađene površine. PRIMJESE: Bijele i sjajne veće primjese, oštih i okruglih bridova (pijesak?). Sitne sjajne. BOJA: 2.5YR 4/4, 10YR 4/3	1	
17	N-131-33; N08-A5-31	Narančasta keramika, mogući tragovi gorenja (korištenja). PRIMJESE: Sitne sjajne, sitne bijele, srednje prozirno bijele. BOJA: 2.5 YR 5/8	2	
18	N-55-4	Narančasto-smeđa keramika sa žučkastim premazom. PRIMJESE: sitne crne sjajne, srednje bijele i prozirne, rijetke srednje crvene; BOJA: 7.5YR 4/3, 5YR 6/6	1	
19	N13-A1-5	Smeđe-okker keramika sa svjetlijom površinom (premaz?). Česte sitne i srednje crne, srednje bijele, srednje sjajne, rijetke srednje smeđenarančaste. BOJA: 2.5YR 4/8, 5YR 6/6	1	

Tab. 26 Katalog grubih keramičkih struktura

FA-BRIC	SPECIMENS	DESCRIPTION	NO. OF DIAGNOSTIC SHARDS	DECORATION
1	2007 NA-1-7; N-55-3; 2008 NA-5-45; N-131-29; N-131-46	Coarse orange pottery with slip that varies from ochre to black. Some shards feature brushed decoration (vertical, horizontal and perhaps wavy incised dense stripes). INCLUSIONS: frequent small white and glossy, frequent medium white and glossy; COLOUR: 2,5YR 4/4, 3/4, 3/6; interior and exterior surface: 2.5YR 3/1	3	Type 2
2	N-16-10; N-5-11; N-14-1; 08-NA-5-19E;	Coarse orange pottery with slip that varies from brown to black. Some shards feature brushed and wavy decoration. INCLUSIONS: small and medium frequent white, occasional small glossy, rare medium red; COLOUR: 2.5Yr 3/2, 3/4, 4/6; surface: GLEY 22.5/5PB, 2.5YR 2.5/1, 10YR 4/2	3	Type 1
3	N-5-9; 08NA-5-19D;	Coarse orange-brown pottery, sometimes with smoothed surface; INCLUSIONS: frequent small and medium white and glossy; COLOUR: 2.5YR 4/6, 2.5/2;	1	
4	N-14-8A; N-117-15A	Coarse pottery with black cross-section and interior, red and smoothed exterior surface. INCLUSIONS: frequent large, medium and small white; COLOUR: Exterior surface 2.5YR 4/6; interior and cross-section 2.5YR 3/1;	1	
5	N-55-2; 13 NA1-2; N-80-1	Coarse pottery that varies from ochre, orange to black-brown (on the surface). Even though surface is smoothed, it is rough and features irregular jutting inclusions. Slip on one shard is cracked. INCLUSIONS: frequent medium white and glossy, occasional large black elongated and round gleaming, frequent small glossy and black. Traces of plant inclusions? COLOUR: Exterior surface 10R 2.5/1, interior surface 10R 5/6;	3	Type 1, Type 3
6	N-101-9; N-9-2	Black coarse pottery with slightly smoothed surface, especially the interior one. INCLUSIONS: frequent white inclusions of various sizes, frequent small glossy, occasional medium glossy; COLOUR: GLEY 1 2.5/N;	2	
7	08 NA-5-25; 08 NA-5-19B; N-131-28; 2008 NA-1-5; N-117-17; N-67-2	Black-brown coarse pottery with smoothed surface still rough on touch. INCLUSIONS: frequent small glossy, frequent small white, very frequent transparent white rectangular of various sizes. COLOUR: 7.5YR 2.5/1;	3	Type 1
8	N-14-2	Black-brown coarse pottery with smoothed surfaces soft on touch. INCLUSIONS: frequent small white and glossy, frequent large white and glossy, frequent medium dark gleaming; COLOUR: "sandwich" cross-section;	1	
9	N-14-3; 08 NA-5-19C	Grey coarse pottery without traces of smoothing on the surface. INCLUSIONS: frequent small and medium glossy, occasional medium white; COLOUR: 7.5YR 2.5/1	1	Type 1
10	N-1-6	Grey-black coarse pottery with small inclusions. Rough on touch. INCLUSIONS: frequent small glossy and white, medium white, on surface rare large white and transparent; COLOUR: 5YR 2.5/1	2	
11	N-98-19	Grey-black coarse pottery, smoothed exterior surface with visible traces of slip (glaze?). INCLUSIONS: frequent small white and glossy, occasional medium and large white, rare large dark grey; COLOUR: 2.5YR	2	
12	08 NA-5-24; 08 NA-5-20; 08 NA-5-19-F; 08 NA-5-21; N-14-8B; N-117-16	Brown-orange coarse pottery with mostly small inclusions, black/blackened on the outside (burnt?). Possible traces of slip. INCLUSIONS: frequent small and medium white, occasional large white and transparent, occasional black glossy of various sizes; glossy on the outside; small glossy golden inclusions visible in the cross-section of shard 5-21; COLOUR: 5YR 2.5/1, 5YR 4/6	4	
13	N-14-8C	Levigated pottery of ochre colour – burnt. INCLUSIONS: frequent small black, glossy and red inclusions. Rare large white-glossy and red. COLOUR: 5YR 5/6; 5YR 2.5/1;	1	
14	08 NA-5-19; N-23-1; N-16-8	Orange coarse pottery. INCLUSIONS: frequent small glossy, frequent medium glossy, frequent white glossy medium and large; COLOUR: 10r 4/8, 7.5YR 2.5/1	1 + 1 vessel	
15	2008 NA-5-32; N-117-15B; N-98-18	Ochre-brown coarse pottery, rough on the surface; INCLUSIONS: frequent small glossy, frequent medium glossy, occasional medium white, occasional small black; COLOUR: 5YR 5/6;	1	
16	N-101-8	Grey-brown pottery, smoothed surface. INCLUSIONS: White and glossy large inclusions, sharp and round edges (sand?). Small glossy. COLOUR: 2.5YR 4/4, 10YR 4/3	1	
17	N-131-33; N08-A5-31	Orange pottery, possible traces of burning (use). INCLUSIONS: Small glossy, small white, medium transparent white. COLOUR: 2.5 YR 5/8	2	
18	N-55-4	Orange-brown pottery with yellowish slip. INCLUSIONS: small black glossy, medium white and transparent, rare medium red. COLOUR: 7.5YR 4/3, 5Yr 6/6	1	
19	N13-A1-5	Brown-ochre pottery with brighter surface (slip?). Frequent small and medium black, medium white, medium glossy, rare medium brown-orange. COLOUR: 2.5YR 4/8, 5YR 6/6	1	

Tab. 26 Catalogue of coarse ceramic fabrics

TIP	Opis	Br. n.	Analogija
1	Metličasti—Guste urezane paralelne vodoravne linije, više ili manje vidljive	N-55-3	Bekić 2009: 109, T. 6: 2, 8; 7; Ruffieux 2010: Fig. 3/4, 7 i dr.
2	Metličasti—Guste urezane paralelne vodoravne linije, više ili manje vidljive, uz povremene okomite kraće linije	N-67-2	Bierbauer 1987: T. 71: 8, 72: 13.
3	Deblje, nepravilne zakrivljene urezane linije	N-55-2	Negri 1994: 70, tav. 5/ 1-4
4	Tanke urezane valovite linije, lagano ukošene	N-14-1	Boltin-Tome 1989-90: T.1: 1, 2, Ruffieux 2010: Fig. 3/3 i dr.
TYPE	DESCRIPTION	No. f.	Analogy
1	Brushed – dense incised parallel horizontal lines, more or less visible	N-55-3	Bekić 2009: 109, Pl. 6: 2, 8; 7; Ruffieux 2010: fig. 3/4, 7 etc.
2	Brushed – dense incised parallel horizontal lines, more or less visible, with occasional vertical short lines	N-67-2	Bierbauer 1987: Pl. 71: 8. 72: 1- 3.
3	Thick, irregular curved incised lines	N-55-2	Negri 1994: 70, tav. 5/ 1-4
4	Thin incised wavy lines, slightly slanted	N-14-1	Boltin-Tome 1989-1990: Pl.1: 1, 2, Ruffieux 2010: fig. 3/3 etc.

Tab. 27 Katalog ukrasa (vidi T. 11)

Tab. 27 *Catalogue of decorations (see Pl. 11)*

Međutim, istodobno ne prestaje trgovina robom koju prevoze afričke i istočnomediteranske amfore, te se njihova pojava u *Fulfinumu* prati sve do 7. stoljeća. Zanimljivu analogiju pruža Tarsatički principij gdje dominiraju afričke amfore sa 78%, slijede ih hispanske (koje na Forumu nisu sa sigurnošću potvrđene), potom italske i bliskoistočne (Višnjic 2009: 134) – trend vrlo sličan onome na *Fulfinumu* (graf. 1).

Prema analizi keramike moguće je zaključiti kako se *Fulfinum*, unatoč svojoj udaljenosti od "glavnoga" jadranskog plovnog puta (npr. Vidrih Perko 2005: Fig. 1; Arnaud 2005: 56–57, 197), ipak, vjerojatno zahvaljujući svojoj luci (Faber 1981; Čaušević 2006; Čaušević-Bully, Valent 2015: 121-123), uspješno snabdijevao posuđem i namirnicama koji su cirkulirali na jadranskom tržištu, kako u ranoj antici tako i kasnije. U prvim stoljećima carstva tako se uglavnom uvozi italska roba – fino stolno posuđe, kuhinjska keramika, amfore – koja je u velikoj mjeri prisutna i na drugim lokalitetima Liburnije (npr. Borzić 2014), iako nedostaje reljefno ukrašena sigilata koja je brojna na pojedinim lokalitetima južne Liburnije (Brusić 1999: 48–49), a prisutna je, u manjoj mjeri, i u Krku.¹⁶

Dominacija afričke robe, u prvom redu amfora, koju smo zamijetili za kvarnersko područje od polovine 2. stoljeća, primjetna je i drugdje na sjeveroistočnom Jadranu (Vidrih Perko 2005: 53–56), dok učestalost importa finoga stolnog posuđa afričke i istočne provenijencije, kako je već rečeno, ipak odskaka, i to u negativnom smislu, od zabilježene istočnojadranske norme (Hayes 1998: 15; Vidrih Perko 2005: 57). U tom kontekstu valja napomenuti i prisutnost ukopa u amforama sjevernoafričkog podrijetla, zasad tek preliminarno obrađenih, unutar kasnoantičke nekropole *Fulfinuma* (Čaušević-Bully 2014).

Osim importa, još je neke od trendova primijećenih za kasnu antiku moguće pratiti duž Jadrana, ali i šire, kada se

Tarsatica, where African amphorae are the dominant type with 78%, followed by Hispanic amphorae (which have not been ascertained at the Forum), and then also Italic and Near Eastern amphorae (Višnjic 2009: 134) – revealing a trend very similar to the one in *Fulfinum* (graph 1).

Based on the pottery analysis we may conclude that *Fulfinum*, in spite of its distance from the "main" Adriatic maritime route (e.g. Vidrih Perko 2005: Fig. 1; Arnaud 2005: 56–57, 197), had nevertheless, owing probably to its harbour (Faber 1981; Čaušević 2006; Čaušević-Bully, Valent 2015: 121-123), successfully obtained supplies of pottery and foodstuffs that circulated in the Adriatic market, both in early antiquity and later. During the first cent. of the Empire, mostly Italic goods were imported—fine tableware, cooking ware, amphorae—which were to a large extent present also at other sites in Liburnia (e.g. Borzić 2014), even though there is an absence of relief-decorated sigillata, which is common at certain sites in southern Liburnia (Brusić 1999: 48–49), as well as in Krk, to a lesser extent.¹⁶

The dominance of African goods, primarily amphorae, observed for the Kvarner region from the mid-2nd cent., is noticeable also elsewhere in the north-eastern Adriatic (Vidrih Perko 2005: 53–56), while the frequency of imports of fine tableware of African and Eastern origin, as already mentioned, deviates, in the negative sense, from the documented eastern Adriatic norm (Hayes 1998: 15; Vidrih Perko 2005: 57). In this context we also have to mention the presence of burials in amphorae of North African origin at the late antique necropolis of *Fulfinum*, which for the time being were only preliminarily analysed (Čaušević-Bully 2014).

Besides imports, there are also some other trends in late antiquity that can be followed along the Adriatic, as well as over a broader area. In that period one notes a return to the

16 Materijal s istraživanja lokaliteta Porta Pisana u Krku (voditelj: R. Starac, PPMHP Rijeka) pregledan je od strane autorice i preliminarno predstavljen, što se reljefne sigilate tiče, na III. međunarodnom kongresu u Crikvenici 2015. godine.

16 The material from the excavations at Porta Pisana in Krk (managed by R. Starac, MHMCL Rijeka) was analysed by the author of this paper, who gave a preliminary presentation of the relief sigillata at the III International Congress in Crikvenica in 2015.

registrira povratak na lokalnu keramičarsku proizvodnju i regionalnu distribuciju, dok se istodobno drastično smanjuje raznovrsnost keramičkih oblika (Arthur 2007: 162, 181, 183), što je vrlo primjetno i unutar fulfinskog materijala.

Municipium Flavium Fulfinum, "drugi" antički grad otoka Krka, prema materijalu koji je analiziran u ovome radu, profilira se kao grad koji je u potpunosti uklopljen u trgovačke trendove rimskodobnog Jadrana, na što su mogli utjecati i razvojačeni pripadnici autohtonog stanovništva kao društvena komponenta koja nam je poznata iz izvora, iako vjerojatno nije bila presudna za formiranje grada. Veterani su sudjelovanjem u rimskom vojničkom životu bili dobro upoznati s tipičnim rimskim stolnim i kuhinjskim navikama, pa tako i s posuđem (Borzić 2011: 77), koje su nastavili koristiti i nakon vojničkog života (npr. Poblome et al. 2014: XIV), što upućuje i na vrstu namirnica koje su se konzumirale i način njihove pripreme. No, valja istaknuti i prisutnost brojnih lokalnih, vjerojatno mahom crikveničkih proizvoda, što *Fulfinum* smješta među konzumente ove lokalne, no ipak tipično rimske, keramičarske radionice. Ranocarski materijal nam stoga govori u prilog uspostave grada kada je proces "romanizacije"¹⁷ ovoga prostora već odavno gotov, pa su njegovi stanovnici u velikoj mjeri posve integrirani u rimski način života, što potvrđuju i grobni prilozi te sam ritus njegove nekropole na Kurilovu. Međutim, kroz kasnija razdoblja grad i dalje intenzivno sudjeluje u importu s Mediterana, što i te kako ide u prilog tezi o postojanju luke i njezina fortificiranja kroz kasnija stoljeća (Faber 1981; 1986/87: 116; Čaušević-Bully, Valent 2015), ali i nastavku života u gradu, ili jednom njegovu dijelu, sve do u 7. stoljeće.

Prijevod i lektura / Translation and proofreading
Sanjin Mihelić

local ceramic production and regional distribution, with a parallel drastic decline in the diversity of ceramic forms (Arthur 2007: 162, 181, 183), which is also very prominent within the material from Fulfinum.

Based on the material analysed in this paper, *Municipium Flavium Fulfinum*, the "second" antique town on the island of Krk, is profiled as a town that is fully incorporated in the commercial trends of the Roman-period Adriatic region, which may have been influenced also by demobilized members of indigenous population as a social element known to us from the sources, although it did probably not play a decisive role in the formation of the town. By virtue of participating in the Roman military life, the veterans were well acquainted with typical Roman eating and cooking habits, which included also pottery (Borzić 2011: 77), which they continued to use even after their military careers had ended (e.g. Poblome et al. 2014: XIV), which points also to the types of foodstuffs they consumed, as well as the method of their preparation. However, we should also point out the presence of numerous local products, probably largely from Crikvenica, which places *Fulfinum* among the consumers of this local, albeit typically Roman, ceramic workshop. The early imperial material therefore speaks in favour of the establishment of the town in the period when the process of "Romanization"¹⁷ of this region had long been completed, so its residents were already to a large extent fully integrated in the Roman way of life, as corroborated by the grave goods and the very rite at the Kurilovo necropolis. However, through later periods the town continued to intensely participate in the import from the Mediterranean, which considerably speaks in favour of the thesis about the existence of a harbour and its fortification in the later cent. (Faber 1981; 1986/87: 116; Čaušević-Bully, Valent 2015), as well as about the continuity of life in the town, or a part of it, up until the 7th cent..

17 Ne ulazeći u rasprave o romanizaciji koje su posljednjih godina okupirale brojne znanstvenike (vidjeti Županek 2008 i ondje citiranu literaturu), u ovom slučaju termin koristimo u smislu prihvatanja rimskih običaja, mode, proizvoda i općenito rimske kulture od strane domorodačkog stanovništva.

17 Without entering the discussion about Romanization which in recent years kept a number of scholars busy (see Županek 2008 and the bibliography quoted there), in this case we use the term in the sense of the acceptance of Roman customs, fashion, products and Roman culture in general, by the indigenous population.

LITERATURA / BIBLIOGRAPHY

- ADS Keay 35A: http://archaeologydataservice.ac.uk/archives/view/amp-hora_ahrb_2005/petrology.cfm?id=218 (18. 12. 2014).
- ADS Late Roman Amphora 1: http://archaeologydataservice.ac.uk/archives/view/amphora_ahrb_2005/details.cfm?id=236 (18. 12. 2014).
- ADS Late Roman Amphora 2: http://archaeologydataservice.ac.uk/archives/view/amphora_ahrb_2005/details.cfm?id=239 (18. 12. 2014).
- Aldini, T. 1978, Anfore Foropopiliensi, *Archeologia Classica*, Vol. XXX, 236–245.
- Aldini, T. 1999, Anfore foropopiliensi in Italia, *Forlimpopoli. Documenti e Studi*, Vol. X, 23–56.
- Arnaud, P. 2005, *Les routes de la navigation antique: itinéraires en Méditerranée*, Editions Errance, Paris.
- Arthur, P. 2007, Form, function and technology in pottery production from Late Antiquity to the early Middle Ages, in: *Technology in transition A.D. 300–650*, Lavan L., Zanini E., Sarantis A. (eds), Brill, Leiden–Boston, 161–186.
- Bailey, D. M. 1980, *A Catalogue of the Lamps in the British Museum II. Roman Lamps made in Italy*, British Museum Publications Ltd., London.
- Bekić, L. 2009, Gruba antička keramika / Roman coarse pottery, in: *Tarsatički principij. Kasnoantičko vojno zapovjedništvo / Principia at Tarsatica. Late roman military headquarters*, Radić Štivić N., Bekić L. (eds.), Rijeka, 101–109.
- Bekić, L., Višnjić, J. 2008, Južni dio antičke nekropole na položaju sv. Marko – Baška, *Vjesnik Arheološkog muzeja u Zagreb*, 3. s. XLI, 209–257.
- Bernal Casasola, D. 2010, Fishing Tackle in Hispania: Reflections, Proposals and First Results, in: *Ancient Nets and Fishing Gear. Proceedings of the International Workshop on "Nets and Fishing Gear in Classical Antiquity: A First Approach"*, Cadiz, November 15–17, 2007, Bekker-Nielsen T., Bernal Casasola D. (eds.), Cadiz–Arhus, 83–138.
- Bet, P., Fenet, A., Montineri, D. 1989, La typologie de la sigillée lisse de Lezoux, ler–Illeme s. Considerations generales et formes inédites, in: *Société Française d'Étude le Céramique en Gaule, Actes du Congrès de Lezoux (4–7 Mai 1989)*, Rivet L. (ed.), Marseille, 37–54.
- Bezjak, J. 2014, Novi arheološki lokaliteti i nalazi u podmorju kvarnerskog akvatorija – rezultati rekonstrukcije od 2010. do 2012. godine, *Portal. Godišnjak Hrvatskog restauratorskog zavoda*, Vol. 5, 23–34.
- Bierbrauer, V. 1987, *In villino – Ibligo in Friaul I. Die Römische Siedlung und das spätantik-frühmittelalterliche Castrum*, C. H. Beck'sche Verlagsbuchhandlung, München.
- Bloier, M. 2012, *Die taucharchäologischen Untersuchungen in der Val Carenta-Bucht auf Brioni (Istrien/Kroatien) 1996/97. Befunde und funde*, Passauer Universitätschriften zur Archäologie 14, Verlag Marie Leidorf, Rahden.
- Boltin-Tome, E. 1989/90, Valovnica na keramici iz Predloke, *Histria archaeologica*, Vol. 20–21, 128–138.
- Bonifay, M. 2004, *Études sur la céramique romaine tardive d'Afrique*, BAR International Series 1301, Archaeopress, Oxford.
- Borzić, I. 2011, Hispanski garum na burnumskom stolu / Hispanic garum at a Burnum table, *Archeologia Adriatica*, Vol. V, 65–88.
- Borzić, I. 2014, Keramičko kuhinjsko posuđe XI. legije s lokaliteta Burnum-Amfiteatar, in: *Zbornik II. međunarodnog arheološkog kolokvija. Rimske keramičarske i staklarske radionice. Proizvodnja i trgovina na jadranskom prostoru. Tema kolokvija: eksperimentalna arheologija*, Crikvenica, 28.–29. listopada 2011., Lipovac Vrkljan G., Šiljeg B., Ožanić Roguljić I., Konestra A. (eds.), Serta Instituti Archaeologici 2, Crikvenica, 287–300.
- Bradara, T. 2006, Keramički i stakleni nalazi iz ulice Porta Stovagnaga i Flaciusove (od 18. do 20. st.) / Pottery and Glass Finds from the Streets of Porta Stovagnaga and Flaciusova (from between the 18th and 20th centuries), in: *Tragovima kamenoklesar. Arheološki nalazi u ulici Porta Stovagnaga / On the Trail of Stonemasons. Archaeological discoveries in Porta Stovagnaga street*, Starac A. (ed.), Monografije i katalogi 17, Arheološki muzej Istre, Pula, 157–183.
- Brajković, T. 2011, Lokalitet Rakitnica – Tri bunara u vodičkom zaleđu / Archaeological site Rakitnica – Tri bunara in Vodice hinterland, in: *Zbornik I. međunarodnog arheološkog kolokvija Rimske keramičarske i staklarske radionice. Proizvodnja i trgovina na jadranskom prostoru*, Crikvenica 23.–24. listopada 2008., Lipovac Vrkljan G., Radić Rossi I., Šiljeg B. (eds.), Crikvenica, 95–101.
- Brusić, Z. 1999, *Hellenistic and Roman Relief Pottery in Liburnia (North-East Adriatic, Croatia)*, BAR International Series 817, Archaeopress, Oxford.
- Buchi, E., 1975, *Lucerne del Museo di Aquileia. Lucerne romane con marchio di fabbrica*, Associazione nazionale per Aquileia, Pordenone.
- Buora, M., Magnani, S., Rosset, G. F. 2012/13, Proposta per la classificazione degli *opercula inscripta*, *Quaderni Friulani di Archeologia*, Vol. XXII–XXIII, 11.
- Carandini, A. 1970, Ceramica a patina cinerognola, in: *Ostia II. Le terme del nuotatore. Scavo dell'ambiente I*, Seminario di archeologia e storia dell'arte greca e romana dell'Università di Roma. Studi Miscellanei 16, De Luca Editore, Roma, 84–86.
- Cavalazzi, M., Fabbri, E. 2010, Cooking ware from the excavation of a 5th–7th century context in Classe (Ravenna, Italy), in: *LRCW 3. Late Roman Coarse Wares, Cooking Wares and Amphorae in the Mediterranean. Archaeology and archaeometry. Comparison between western and eastern Mediterranean*, Vol. II, Menchelli S., Santoro S., Pasquinucci M., Guiducci G. (eds.), BAR International Series 2185 (II), Oxford, 623–633.
- Cavaliere, M., Boldrini, E., Bossu, C., De Idonè, P., Fumo, A. 2012, Aspetti della cultura materiale nelle fasi di riutilizzo (V–inizi VII sec. d.C.) della villa romana di Aiano–Torraccia di Chiusi (San Gimignano, Siena/Italy). Note preliminari, *Rei Cretariae Romanae Fautorum Acta*, Vol. 42, 169–180.
- Chinelli, R. 1991, Coperchi d'anfora, in: *Scavi di Aquileia I. L'area a est del foro. Rapporto degli scavi 1988*, Verzar-Bass M. (ed.), Edizioni Quasar, Roma, 243–259.
- Chinelli, R. 1994, Coperchi d'anfora, in: *Scavi di Aquileia I. L'area a est del foro. Rapporto degli scavi 1989–91*, Verzar-Bass M. (ed.), Edizioni Quasar, Roma, 464–490.
- Chinelli, R., Mosser, M., Sedlmayer, H. 2007, Vindobona: prodotti italici tra la zona padano-adriatica e il danubio. La testimonianza di alcune classi materiali, *Antichità altoadriatiche*, Vol. LXV, 817–841.
- Chinelli, R., Tirone, C. 1991, Ceramica depurata, in: *Scavi di Aquileia I. L'area a est del foro. Rapporto degli scavi 1988*, Verzar-Bass M. (ed.), Edizioni Quasar, Roma, 162–178.
- Chinelli, R., Tirone, C. 1994, Ceramica depurata, in: *Scavi di Aquileia I. L'area a est del foro. Rapporto degli scavi 1989–91*, Verzar-Bass M. (ed.), Edizioni Quasar, Roma, 238–289.
- Cirelli, E. 2009, Anfore globulari a Classe nell'alto Meiodoevo, in: *Atti del V Congresso Nazionale di Archeologia Medievale*. Palazzo della Dogana, Salone del Tribunale (Foggia); Palazzo dei Celestii, Auditorium (Manfredonia); 30 settembre–3 ottobre 2009, Volpe G., Favia P. (eds.), Firenze, 563–568.
- Cvjetičanin, T. 2001, *Gleđosana keramika Gornje Mezije / Glazed pottery from Upper Moesia*, Narodni Muzej Beograd, Beograd.
- Čaušević, M. 2006, Les cités antiques des îles du Kvarner dans l'Antiquité tardive – exemples de *Curicum*, *Fulfinum* et *Apsorus* / Antički gradovi kvarnerskih otoka u kasnoj antici – primjeri gradova *Curicum*, *Fulfinum* i *Apsorus*, *Hortus Artium Medievalium*, Vol. 12, 19–41.
- Čaušević-Bully, M. 2014, La ville de *Fulfinum* (île de Krk). Nouveau regard sur le sort d'une ville antique entre l'Antiquité tardive et le haut Moyen âge, *Hortus Artium Medievalium*, Vol. 20, 157–169.
- Čaušević-Bully, M., Valent, I. 2015, *Municipium Flavium Fulfinum*. Dijakronijska studija gradske strukture s posebnim osvrtom na forumski prostor, *Prilozi Instituta za arheologiju u Zagrebu*, Vol. 32 2015, 111–146.
- Dautova Ruševljan, V. 1970, Tipologija kvarnerskih amfora, *Diadora*, Vol. 5, 161–170.
- Dautova Ruševljan, V. 1973, Ranorimska nekropola u uvali Sepen kod Omišlja na otoku Krku, *Diadora*, Vol. 6, 181–205.
- Delage R. 2010, La sigillée de Lesoux, in: *La céramique en Gaule du Nord. Dictionnaire des céramiques. La Vaiselle à large diffusion*, Bulet R., Vilverder F., Delage R. (ed.), Brepols, Turnhout, 95–125.
- Di Filippo Balestrazzi, E. 1988, *Lucerne del Museo di Aquileia. Lucerne romane di età repubblicana ed imperiale*, Vol. II, 1, 2, Associazione nazionale per Aquileia, Pordenone.
- Di Giovanni, V. 1996, Produzione e consumo della ceramica da cucina nella Campania romana (II a.C.–II d.C.), in: *Les céramiques communes de Campanie et de Narbonnaise (Ier s. av. J.-C. – Ier s. ap. J.-C.)*. La vaiselle de cuisine et de table, Actes des Journées d'étude organisées par le Centre Jean Bérard et la Soprintendenza Archeologica per

- le Provincie di Napoli e Caserta, Naples, 27-28 mai 1994, Bats M. (ed.), Collection du Centre Jean Berard 14, Napoli.
- Di Giovanni, V., Soricelli, G. 2013, Produzione e circolazione della ceramica da cucina nella Campania romana. Tradizioni formali e contesti a confronto, in: *Atti del convegno Immensa Aequora Workshop. Ricerche archeologiche, archeometriche e informatiche per la ricostruzione dell'economia e dei commerci nel bacino occidentale del Mediterraneo (metà IV sec. a.C. – I sec. d.C.)*, Roma 24-26 gennaio 2011., Olcese G. (ed.), Edizioni Edizioni Quasar, Roma.
- Dobrova, D., Luise, B. 2012/13, I coperchi d'anfora dagli scavi dei fondio ex Cossar ad Aquileia. Dai vecchi dati ai nuovi ritrovamenti, *Quaderni Friulani di Archeologia*, Vol. XXII–XXIII, 77–94.
- Dugonjić, P. 2010, Rezultati rekognosciranja podmorskih pozicija na području Kvarnera 2008. i 2009. godine, in: *Arheološka istraživanja na srednjem Jadranu*, Ivčević S. (ed.), Izdanja HAD-a, Zagreb, 211–225.
- Ettlinger, E., Hedinger, B., Hoffmann, B., Kenrick, P. M., Pucci, G., Roth-Rubi, K., Schneider, G., von Schnurbein, S., Wells, C. M., Zabehlicky-Scheffenecker, S. 1990, *Conspectus formarum terrae sigillatae italico modo confectae*, Römisch-Germanische Kommission des Deutschen Archäologischen Instituts zu Frankfurt a. M., Dr. Rudolf Habelt, Bonn.
- Faber, A. 1981, Luka antičkog Fulfina na otoku Krku, *Pomorski zbornik*, Vol. 19, 293–314.
- Faber, A. 1986/87, Osvrt na neka utvrđenja otoka Krka od vremena prethistorije do antike i srednjeg vijeka, *Prilozi Instituta za arheologiju u Zagrebu*, Vol. 3–4, 113–140.
- Fadić, I. 1999, Nalazi iz devastiranih antičkih grobova u Senju, *Senjski zbornik*, Vol. 26, 51–69.
- Gelichi, S. 1998, Ceramiche tipo Classe, in: *Ceramica in Italia: VI–VII secolo. Atti del Convegno in onore di John W. Hayes, Roma 1995*, Sagui L. (ed.), All'Insegna del Giglio, Firenze, 481–485.
- Gelichi, S., Negrelli, C. 2008, Anfore e commerci nell'alto Adriatico tra VIII e IX secolo, *Mélanges de l'Ecole française de Rome. Moyen-Age*, Vol. 120/2, 307–326.
- Gelichi, S., Negrelli, C., Calao, D., Grandi, E. 2006, Comacchio tra IV e IX secolo d.C.: territorio, abitato e infrastrutture, in: *Atti del IV Congresso Nazionale di Archeologia Medievale. Scriptorium dell'Abbazia, Abbazia di San Galgano (Chiusdino, Siena), 26-30 Settembre 2006*, Francovich R., Valenti M. (eds.), Firenze, 114–123.
- Ghalia, T., Bonifay, M., Capelli, C. 2005, L'atelier de Sidi-Zahrani: mise en évidence d'une production d'amphores de l'antiquité tardive sur le territoire de la cité de Neapolis (Nabeul, Tunisie), in: *LRCW I - Late Roman Coarse Wares, Cooking Wares and Amphorae in the Mediterranean. Archaeology and Archaeometry*, Gurt J. M., Buxeda J., Cau M. A. (eds.), Archaeopress, Oxford, 495–507.
- Giovannini, A., Mandruzzato, L., Mezzi, M. R., Pasini, D., Ventura, P. 1998, Recenti indagini nelle necropoli aquileiesi: Beligna, scavo 1992–1993, *Aquileia Nostra*, Vol. LXIX, 205–358.
- Glušćević, S. 1990, Rimska nekropola u Kaljskoj ulici, *Diadora*, Vol. 12, 107–194.
- Guglielmetti, A., Lecca Bishop, L., Ragazzi, L. 1991, Ceramica comune, in: *Scavi MM3. Ricerche di archeologia urbana a Milano durante la costruzione della linea 3 della metropolitana 1982-1990*, vol. 3.1, Caporusso D. (ed.), Edizioni ET, Milano, 133–258.
- Hayes, J. W. 1983, The Villa Dionysos Excavations, Knossos: The Pottery, *The Annual of the British School at Athens*, Vol. 78, 97–169.
- Hayes, J. W. 1985, Sigillate orientali, in: *Enciclopedia dell'arte antica, classica e orientale. Atlante delle forme ceramiche II. Ceramica fine romana nel bacino Mediterraneo (tardo Ellenismo e primo Impero)*, Istituto della Enciclopedia Italiana, Roma, 1–96.
- Hayes, J. W. 1998, Introduction. The Study of Roman Pottery in the Mediterranean: 23 Years After Late Roman Pottery, in: *Ceramica in Italia: VI–VII secolo. Atti del Convegno in onore di John W. Hayes, Roma 11-13 Maggio 1995*, Sagui L. (ed.), Vol. I, All'Insegna del Giglio, Firenze, 9–22.
- Horvat, J. 1997, Pokrovčki za amfore / Amphora Lids, in: *Sermin. Prazgodovinska in zgodnjerimska naselbina v severozahodni Istri / A Prehistoric and Early Roman Settlement in Northwestern Istria*, Horvat J. (ed.), Založba ZRC SAZU, Ljubljana, 77–82.
- Jelincić Vučković, K. 2011, Luke kod Škripa na otoku Braču – novi arheološki nalazi, *Archeologia Adriatica*, Vol. V, 127–149.
- Jurišić, M. 2000, *Ancient shipwrecks of the Adriatic. Maritime transport during the first and second centuries AD*, BAR International Series 828, Archaeopress, Oxford.
- Katić, M. 1999/2000, Uvod u proučavanje keramičkih radionica Farosa, *Opuscula archaeologica*, Vol. 23–24, 49–58.
- Keay, S. J. 1984, *Late Roman Amphorae in the Western Mediterranean. A typology and economic study: the Catalan evidence*, BAR International Series 196, Oxford.
- Konestra, A. 2013, Ricerche nei musei della Liburnia settentrionale (Quarnero, Croazia): potenzialità, nuove attestazioni e aggiornamenti sulla diffusione di alcune tipologie ceramiche, in: *Scavare nei Musei. Elementi di novità e questioni di metodo, Incontro di studio, Aquileia, 7 giugno 2013, ??? –???*. (u tisku).
- Konestra, A. 2014, La ceramica dai corredi funerari della necropoli Kurilovo conservata nella collezione archeologica del JANAF, in: *Zbornik II. međunarodnog arheološkog kolokvija. Rimske keramičarske i staklarske radionice. Proizvodnja i trgovina na jadranskom prostoru. Tema kolokvija: eksperimentalna arheologija*, Crikvenica, 28.–29. listopada 2011., Lipovac Vrkljan G., Šiljeg B., Ožanić Roguljić I., Konestra A. (eds.), Serta Instituti Archaeologici 2, Crikvenica, 259–277.
- Košćević, R., Makjanić, R. 1986/87, Antički tumuli kod Velike Gorice i nova opažanja o Panonskoj radionici glazirane keramike, *Prilozi Instituta za arheologiju u Zagrebu*, Vol. 3–4, 25–70.
- Labate, D. 1988, Rozza terracotta e ceramica comune: una proposta tipologica, in: *Modena dalle origini all'anno mille. Studi di archeologia e storia*, Vol. II, Edizioni Panini, Modena, 60–80.
- Lavazza, A., Vitali, M. G. 1994, La ceramica d'uso comune: problemi generali e note su alcune produzioni taroantiche e medievali, in: *Ad mensam. Manufatti d'usa da contesti archeologici fra tarda antichità e medioevo*, Lusiardi Siena S. (ed.), Del Bianco, Udine, 17–54.
- Lipovac Vrkljan, G. 2009, Pottery manufacture in Crikvenica, in: *Olio e pesce in epoca romana: Produzione e commercio nelle regioni dell'alto Adriatico - Atti del Convegno*, Padova, 16 Febbraio 2007, Pesavento Mattioli S., Carre M.-B. (eds.), Edizioni Edizioni Quasar, Padova, 309–314.
- Lipovac Vrkljan, G. 2011, Lokalna keramičarska radionica Seksta Metilija Maksima u Crikvenici. Crikveničke amfore ravnog dna, in: *Zbornik I. međunarodnog arheološkog kolokvija Rimske keramičarske i staklarske radionice. Proizvodnja i trgovina na jadranskom prostoru*, Crikvenica 23.–24. listopada 2008., Lipovac Vrkljan G., Radić Rossi I., Šiljeg B. (eds.), Crikvenica, 3–18.
- Lipovac Vrkljan, G., Šiljeg, B. 2008, Istraživanje lokaliteta Crikvenica–Igralište 2007., *Annales Instituti Archaeologici*, Vol. IV, 88–92.
- Loeschke, S. 1919, *Lampen aus Vindonissa. Ein Beitrag zur Geschichte von Vindonissa und des antiken Beleuchtungswesens*, In Kommission bei Beer & Cie. in Zürich und bei Joseph Baer & Cie. in Frankfurt a. M., Zürich.
- Maccabruni, C. 1976, Ceramica invetriata di età romana nel Pavese, *Bollettino della Società Pavese di Storia Patria*, Anno LXXIV–LXXV, Vol. XXVI–XXVII, fasc. I–IV (1974/75), 61–76.
- Maggi, P. 2006, La distribuzione delle sigillate di produzione orientale nell'arco Adriatico nord-orientale: problemi di metodo, in: *Les routes de l'Adriatique antique. Géographie et économie. Actes de la table ronde des 18 au 22 septembre 2001 Zadar*, Čače S., Kurilić A., Tassaux F. (eds.), Bordeaux–Zadar, 179–194.
- Makjanić, R. 1983, Istočna sigilata na Kvarneru, *Prilozi Instituta za arheologiju u Zagrebu*, Vol. 1, 51–64.
- Makjanić, R. 1985, Terra sigillata iz rimskih nekropola u Osoru i Bakru, *Prilozi Odjela za arheologiju*, Vol. 2, 39–50.
- Makjanić, R. 1987, Plain Italian sigillata on the northeast Adriatic coast and at Sisak, *Rei Cretariae Romanae Fautorum Acta*, Vol. XXV–XXVI, 225–239.
- Makjanić, R. 1988, Notes on Later Arretine and "North Italian" Plain Sigillata Supply, *Bulletin of the Institute of Archaeology*, Vol. 25, 55–65.
- Manacorda, D. 1977, Le anfore, in: *Ostia IV. Le terme del nuotatore. Scavo dell'ambiente XVI e dell'area XXV*, Carandini A., Panella C. (eds.), Seminario di archeologia e storia dell'arte greca e romana dell'Università di Roma. Studi Miscellanei 23, De Luca Editore, Roma, 116–266.
- Martin, A. 1992, La ceramica invetriata romana: la testimonianza dell'Area NE delle Terme del Nuotatore ad Ostia, in: *La ceramica invetriata tardoantica e altomedievale in Italia*, Atti del Seminario, Certosa di Pontignano (Siena), 23-24 febbraio 1990, Paroli L. (ed.), Firenze, 323–329.
- Martin, A. 1995, Central Italian Lead-Glazed Ware, *Rei Cretariae Romanae Fautorum Acta*, Vol. 34, 63–68.

- Marušić, B. 1986, Prilog poznavanju kasnoantičkog Nezakcija, *Starohrvatska prosvjeta*, Vol. 16, 51–76.
- Massari, G., Ratti, G. 1977, Osservazioni sulla ceramica comune di Luni, in: *Scavi di Luni, II, 2. Relazione delle campagne di scavo 1972-1973-1974*, Frova A. (ed.), Giorgio Bretschneider Editore, Roma, 590–630.
- Matejčić, R. 1976, Petnaest godina hidroarheoloških istraživanja u Kvarneru, *Pomorski zbornik*, Vol. 14, 345–361.
- Matijašić, R. 1983, Cronografia dei bolli laterizi della figulina pansiana nelle regioni adriatiche, *Mélanges de l'École française de Rome. Antiquité*, Vol. 95/2, 961–995.
- Matijašić, R. 1991, Campus Martius. *Antička nekropola između Premanturske i Medulinske ulice u Puli (Istraživanje 1985–1986. godine)*, Monografije i katalozi 8, Arheološki muzej Istre, Pula.
- Matijašić, R. 2009, Instrumentum Varvarinum: izbor iz poharanog depoa, in: *Studia Varvarina*, Vol. 1, Kuntić-Makvić B. (ed.), Zagreb–Motovun, 91–129.
- Miše, M., Čargo, B. 2010, Lončarska proizvodnja u Isi, *Vjesnik za arheologiju i povijest dalmatinsku*, Vol. 103, 7–40.
- Modrijan, Z. 2011, Keramika, in: *Poznoantična utrjena naselbina Tonovcov grad pri Kobaridu. Najdbe*, Modrijan Z., Milavec T. (eds.), Opera Instituti Archaeologici Slovenica 24, Institut za arheologiju ZRC SAZU, Založba ZRC, Ljubljana, 121–219.
- Negri, A. 1994, La ceramica grezza medievale in Friuli-Venezia Giulia: gli studi e le forme, in: *Ad mensam. Manufatti d'usa da contesti archeologici fra tarda antichità e medioevo*, Lusiardi Siena S. (ed.), Del Bianco, Udine, 63–96.
- Ortalli, J., Baldoni, D., Pellicioni, M. T. 2008, *Pian di Bezzo di Sarsina, la necropoli romana*, Bologna.
- Oštarić, I., Kurilić, A. 2013, *Arheološka karta otoka Paga*, Ogranak Matice hrvatske u Novalji, Grad Novalja, Novalja.
- Oxè, A., Comfort, H., Kenrick, P. M. 2000, *Corpus Vasorum Arretinorum. A Catalogue of Signature, Shapes and Chronology of Italian Sigillata*, Dr. Rudolf Habelt, Bonn.
- Ožanić Roguljić, I. 2011, Terra sigillata i keramika tankih stijenki s lokaliteta Crikvenica – "Igralište" / Terra sigillata and thin-walled pottery from the site of Crikvenica – "Igralište", in: *Zbornik I. međunarodnog arheološkog kolokvija Rimske keramičarske i staklarske radionice. Proizvodnja i trgovina na jadranskom prostoru*, Crikvenica 23.–24. listopada 2008., Lipovac Vrkljan G., Radić Rossi I., Šiljeg B. (eds.), Crikvenica, 31–38.
- Ožanić Roguljić, I. 2012, *Klasifikacija i tipologija rimske keramike s lokaliteta Crikvenica Igralište – proizvodi keramičarske radionice Seksta Metilija Maksima*, doktorska disertacija, Filozofski fakultet Sveučilišta u Zagrebu, Zagreb.
- Ožanić Roguljić 2012a, Pottery from the workshop of Sextus Metilius Maximus (Crikvenica–Igralište/Ad Turres, Northern Dalmatia), in: *Rei Cretae Romanae Fautorum Acta*, Vol. 42, 125–132.
- Ožanić Roguljić, I., Konestra, A. 2012, Rassegna topografica e cronologica delle lucerne fittili romane dalla regione del Quarnero (Croazia), in: *IV. International Congress of the International Lychnological Association*, Ptuj 15.–19. May 2012, ??? – ???, (u tisku).
- Pannuzzi, S. 2000, Produzione e consumo a Roma di ceramica invetriata da fuoco tra XVI e XVII secolo, in *Atti del II Congresso Nazionale di Archeologia Medievale. Musei Civici, Chiesa di Santa Giulia (Brescia, 28 settembre-1 ottobre 2000)*, Brogiolo G. P. (ed.), All'Insegna del Giglio, Firenze, 453–461.
- Pavišić, I. 1983, Prilog poznavanju importa u antičkom Fulfinumu, *Prilozi Instituta za arheologiju u Zagrebu*, Vol. 1, 39–50.
- Pavolini, C. 1985, Decorazioni di Navigius o di altro tipo. Forme VIII e IX, in: *Enciclopedia dell'arte antica, classica e orientale. Atlante delle forme ceramiche I. Ceramica fine romana nel bacino Mediterraneo (medio e tardo Impero)*, Istituto della Enciclopedia Italiana, Roma, 192–198.
- Pedišić, I., Podrug, E. 2007, Antički opekarski pečati iz fundusa Muzeja grada Šibenika / Roman brick workshop stamps from the collection of the Šibenik City Museum, *Opuscula archaeologica*, Vol. 31 (2008), 81–142.
- Percan, T. 2009, Antička fina keramika / Roman fine pottery, in: *Tarsatički principij. Kasnoantičko vojno zapovjedništvo / Principia at Tarsatica. Late roman military headquarters*, Radić Štivić N., Bekić L. (eds.), Rijeka, 69–96.
- Pesavento Mattioli, S. 2014, Le produzioni di amfore vinarie nei territori adriatici: questioni di metodo / Proizvodnja vinskih amfore na Jadranu: metodološka pitanja, in: *Zbornik II. međunarodnog arheološkog kolokvija. Rimske keramičarske i staklarske radionice. Proizvodnja i trgovina na jadranskom prostoru. Tema kolokvija: eksperimentalna arheologija*, Crikvenica, 28.–29. listopada 2011., Lipovac Vrkljan G., Šiljeg B., Ožanić Roguljić I., Konestra A. (eds.), Serta Instituti Archaeologici 2, Crikvenica, 191–198.
- Pešić, M. 2011, Katalog – Svakodnevna keramika / Catalogo – Ceramica d'uso quotidiano, in: *Podvodna arheološka istraživanja uvala Veštar 2008. – 2010. / Ricerche archeologiche subacquee nella baia di Vestre 2008 – 2010*, Bekić L., Višnjić J., Pešić M., Bloier M. (eds.), Zavičajni Muzej Grada Rovinja, Rovinj, 43–66.
- Pešić, M. 2013, Connections between Eastern Adriatic Coast and African Provinces in the Period from 2nd – 5th Century AD Based on the Underwater Finds of Amphorae in Croatia, in: *SOMA 2012, Identity and Connectivity, Proceedings of the 16th Symposium on Mediterranean Archaeology*, Florence, Italy, 1–3 March 2012, Vol. II, Bombardieri L., D'Agostino A., Guarducci G., Orsi V., Valentini S. (eds.), BAR International series 2581 (II), Archaeopress, Oxford, 1207–1215.
- Plesničar-Gec, Lj. 1977, *Keramika emonskih nekropol / The Pottery of Emona Necropolises*, Dissertationes et Monographie, Mestni muzej, Ljubljana.
- Poblome, J., Malfitana, D., Lund, J., 2014, It's Complicated ... Past Cultural Identity and Plain Broken Pottery, *Rei Cretae Romanae Fautorum Acta*, Vol. 43, XI–XVII.
- Radić Štivić N., Bekić L. (eds.), 2009, *Tarsatički principij. Kasnoantičko vojno zapovjedništvo / Principia at Tarsatica. Late roman military headquarters*, Rijeka.
- Riccobono, D. 2007, Ceramica comune grezza, in: *Trieste antica. Lo scavo di Crosada. I materiali*, Moreselli C., Auriemma R., Maggi P. (eds.), Editreg, Trieste, 105–115.
- Riley, J. A. 1979, Coarse pottery, in: *Excavations at Sidi Khrebish. Benghazi (Berenice)*, Vol. II, Lloyd L. A. (ed.), Libya Atiqua V, Tripoli, 91–465.
- Rinaldi, F., Gobbo, V., Sandrini, G.M. 2012/13, Tappi d'anfora da un intervento di archeologia urbana apud horrea a Julia Concordia, *Quaderni Friulani di Archeologia*, Vol. XXII–XXIII, 67–75.
- Roffia, E. 1976, Ceramica a patina cenerognola, in: *Scavi di Luni, II, 1. Relazione delle campagne di scavo 1972-1973-1974*, Frova A. (ed.), Giorgio Bretschneider Editore, Roma, 180–183.
- Ruffieux, P. 2010, Céramique commune de l'antiquité tardive découverte sur le site de l'église Sainte-Cécile a Guran, en Istrie, *Hortus Artium Medievalium*, Vol. 16, 247–266.
- Rupel, L. 1991, Ceramica comune, in: *Scavi di Aquileia I. L'area a est del foro. Rapporto degli scavi 1988*, Verzar-Bass M. (ed.), Roma, 145–180.
- Rupel, L. 1994, Ceramica comune, in: *Scavi di Aquileia I. L'area a est del foro. Rapporto degli scavi 1989-91*, Verzar-Bass M. (ed.), Roma, 145–180.
- Saccardo, L. 1985, Ceramica comune: urne e ciotole-coperchio, in: *Angera romana. Scavi nella necropoli 1970-1979*, Vol. 2, Sena Chiesa G. (ed.), Giorgio Bretschneider Editore, Roma, 469–481.
- Samford, P. M. 1997, Response to a Market: Dating English Underglaze Transfer-Printed Wares, *Historical Archaeology*, Vol. 31, No. 2, 1–30.
- Schindler Kaudelka, E. 1975, *Die dünnwandige Gebrauchskeramik vom Magdalensberg*, Archäologische Forschungen zu den Grabungen auf dem Magdalensberg 3, Kärntner Museumsschriften 58, Klagenfurt.
- Schindler Kaudelka, E. 2012, Céramiques communes du Magdalensberg. Un cas exceptionnel dans le Norique, in: *Les céramiques communes comprises dans leur contexte régional facies de consommation et mode d'approvisionnement*, Actes de la table ronde organisée à Lyon les 2 et 3 février 2009 à la Maison de l'Orient et de la Méditerranée, Batigne Vallet C. (ed.), TMO 60, Lyon.
- Schindler Kaudelka, E. 2012a, La ceramica a pareti sottili del Magdalensberg 1975–1998–2011, in: *Emona: med Akvilejo in Panonijo / Emona: between Aquileia and Pannonia*, Lazar I., Županek B. (eds.), Univerza na Primorskem, Koper, 323–366.
- Schindler, M., Scheffenecker, S. 1977, *Die glatte rote Terra sigillata vom Magdalensberg*, Verlag des Landesmuseums für Kärnten, Klagenfurt.
- Sena Chiesa, G., Ceramica a pareti sottili, in: *Angera romana. Scavi nella necropoli 1970-1979*, Vol. 2, Sena Chiesa G. (ed.), Giorgio Bretschneider Editore, Roma, 389–426.
- Sfreda, N., Tassinari, G. 1998, Ceramica invetriata di età alto imperiale, in: *Ceramiche in Lombardia tra II sec. a.C. e VII sec. d.C. Raccolta dei dati editi*, Olcese G. (ed.), Documenti di Archeologia 16, Editore S.A.P., Mantova, 75–79.
- Starac, A. 2006, Tragovima kamenoklesara. Arheološki nalazi u ulici Por-

- ta Stovagnaga / On the Trail of Stonemasons. Archaeological discoveries in Porta Stovagnaga street, in: *Tragovima kamenoklesar. Arheološki nalazi u ulici Porta Stovagnaga / On the Trail of Stonemasons. Archaeological discoveries in Porta Stovagnaga street*, Starac A. (ed.), Monografije i katalozi 17, Arheološki muzej Istre, Pula, 9–156.
- Starac, R. 1991, Antička keramika na lokalitetu "Igralište" u Crikvenici, *Vinodolski zbornik*, Vol. 6, 221–233.
- Starac, R. 1999, Rezultati arheološkog sondiranja na trgu Cimiter, *Senjski zbornik*, Vol. 26, 71–88.
- Starac, R. 2004, Prilog poznavanju materijalne kulture stanovnika Tarsatičke Liburnije između petog i devetog stoljeća, *Sveti Vid – zbornik*, Vol. IX, 21–37.
- Šiljeg, B., Lipovac Vrkljan, G., Ožanić Roguljić, I., Konestra, A. 2013, Crikvenica – *Ad turres*, rezultati sustavnih arheoloških istraživanja rimske keramičarske radionice na lokalitetu Igralište 2012. godine, *Annales Instituti Archaeologici*, Vol. IX, 121–130.
- Šešelj, L. 2005, Utjecaji dirahijskih keramičkih radionica na području srednje Dalmacije, *Vjesnik za arheologiju i povijest dalmatinsku*, Vol. 98, 49–61.
- Šimić-Kanaet, Z. 2010, *Tilurium II. Keramika 1997-2006*, Vol. I i II, Sanader M., Tončinić D., Kaić I. (eds.), Golden Marketing–Tehnička knjiga, Arheološki zavod Filozofskog fakulteta u Zagrebu, Zagreb.
- Tirone C. 1994, Ceramica comune. Olle, in: *Scavi di Aquileia I. L'area a est del foro. Rapporto degli scavi 1989-91*, Verzar-Bass, M. (ed), Edizioni Quasar, Roma, 265–268.
- Topić, M. 2003, Stolno posuđe i glinene svjetiljke iz Augusteuma Narone, *Vjesnik za arheologiju i historiju dalmatinsku*, Vol. 95 (2002), 183–344.
- Topić, M. 2004, Posuđe za svakodnevnu upotrebu grublje izradbe, amfore, terakote i kultne posude iz Augusteuma Narone / Coarse ware, amphorae, terracotta and cult vessels from the Augusteum at Narona, Narona VIII, *Vjesnik za arheologiju i historiju dalmatinsku*, Vol. 96 (2003), 303–515.
- Tortorella, S. 1981, Ceramica africana. Ceramica da cucina, in: *Enciclopedia dell'arte antica, classica e orientale. Atlante delle forme ceramiche I. Ceramica fine romana nel bacino Mediterraneo (medio e tardo Impero)*, Istituto della Enciclopedia Italiana, Roma, 208–227.
- Vidrih Perko, V. 2005, Seaborne trade Routes in the North-East Adriatic and their Connections to the Hinterland in Late Antiquity, in: *L'Adriatico dalla Tarda Antichità all'età Carolingia, Atti del convegno di studio, Brescia 11-13 ottobre 2001*, Brogiolo G. P., Delogu P. (eds.), All'Insegna del Giglio, Firenze, 49–77.
- Villa, L. 1998, Alcuni aspetti della circolazione di prodotti di importazione in Friuli tra VI e VII secolo, in: *Ceramica in Italia: VI-VII secolo. Atti del Convegno in onore di Jonh W. Hayes, Roma 11-13 Maggio 1995*, Sagui L. (ed.), Vol. I, All'Insegna del Giglio, Firenze, 1998, 275–287.
- Višnjić, J. 2009, Amfore / Amphorae, in: *Tarsatički principij. Kasnoantičko vojno zapovjedništvo / Principia at Tarsatica. Late roman military headquarters*, Radić Štivić N., Bekić L. (eds.), Rijeka, 121–151.
- Višnjić, J. 2011, Srednjovjekovna i novovjekovna keramika / Ceramica medievale e postmedievale, in: *Podvodna arheološka istraživanja uvala Veštar 2008. – 2010. / Ricerche archeologiche subacquee nella baia di Vestre 2008 – 2010*, Bekić L., Višnjić J., Pešić M., Bloier M. (eds.), Zavičajni Muzej Grada Rovinja, Rovinj, 24–30.
- Višnjić, J., Bekić, L., Pleština, I. 2010, Arheološka istraživanja na prostoru antičke uljare u uvali Marić (Porto Marriccio) kod Barbarige. Rannocarski gospodarski kompleks – utočiste kasnoantičkog stanovništva, *Portal. Godišnjak Hrvatskog restauratorskog zavoda*, Vol. 1, 229–259.
- Warner Slane, K. 1990, The Sanctuary of Demeter and Kore. The Roman pottery and lamps, *Corinth. Results of excavations conducted by The American School of classical studies at Athens*, Vol. XVIII, pt. 2, The American School of classical studies at Athens, Princeton, New Jersey.
- Zabehlicky Scheffenegger, S. 1979, Die Kleinfunde, in: *Burnum I. Erste bericht über die Kleinfunde der grabungen 1973 und 1974 auf dem Forum*, Zabehlicky Scheffenegger S. (ed.), Österreichische Akademie der Wissenschaften, Schriften der Balkankommission, Antiquarische abteilung XIV, Verlag der Österreichische Akademie der Wissenschaften, Wien.
- Županek, B. 2008, Iskanje prave poti: romanizacija v slepi ulici? / The Search for the Right Path: Has Romanisation Found Itself in a Cul-de-sac?, *Arheo*, Vol. 25, 31–38.

T. 1

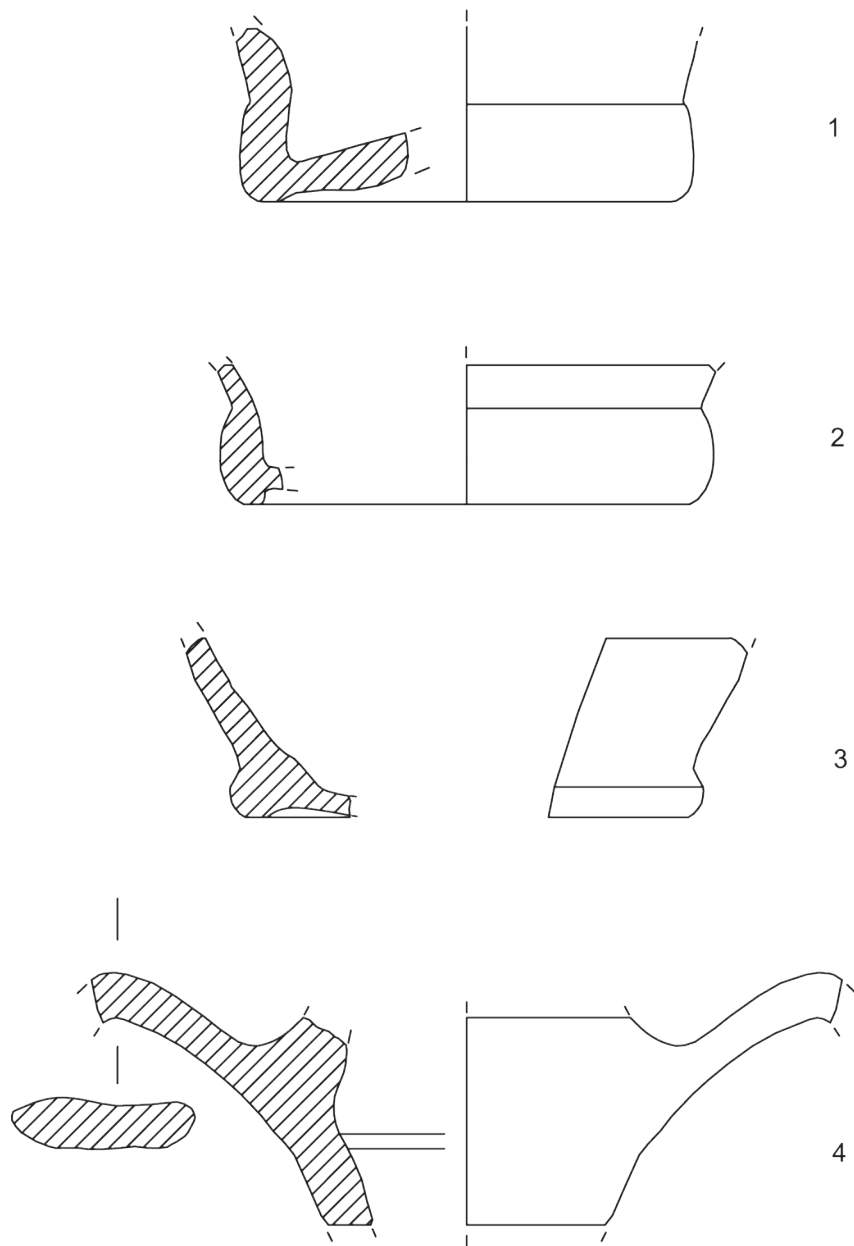

T. 1 Italske i jadranske amfore (crteže izradila: A. Konestra)

Pl. 1 *Italic and Adriatic amphorae* (drawings by A. Konestra)

T. 2

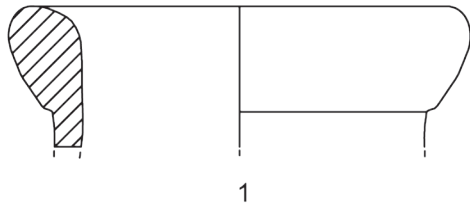

1

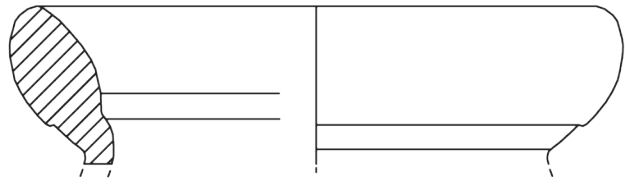

2

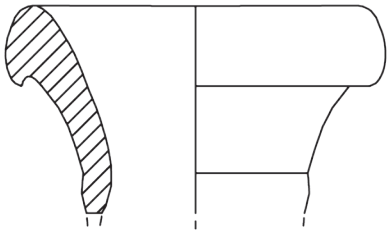

3



4

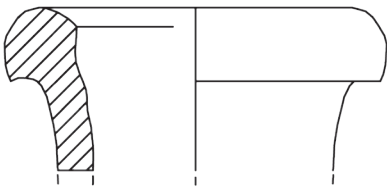

5

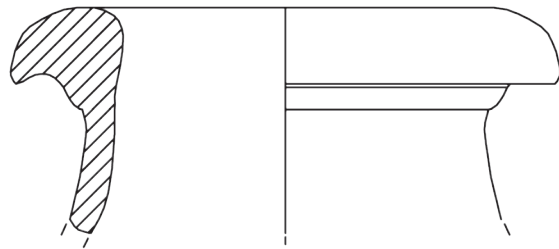

6



7

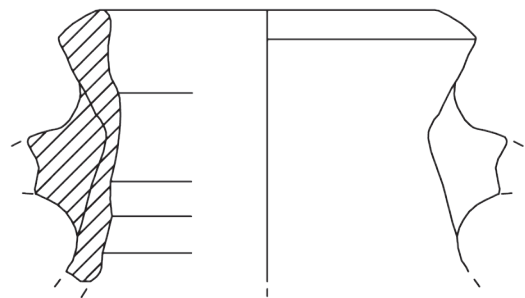

8

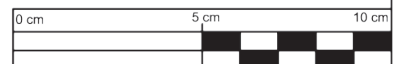

T. 2 Afričke amfore – rubovi (crteže izradila: A. Konestra)

Pl. 2 African amphorae – rims (drawings by A. Konestra)

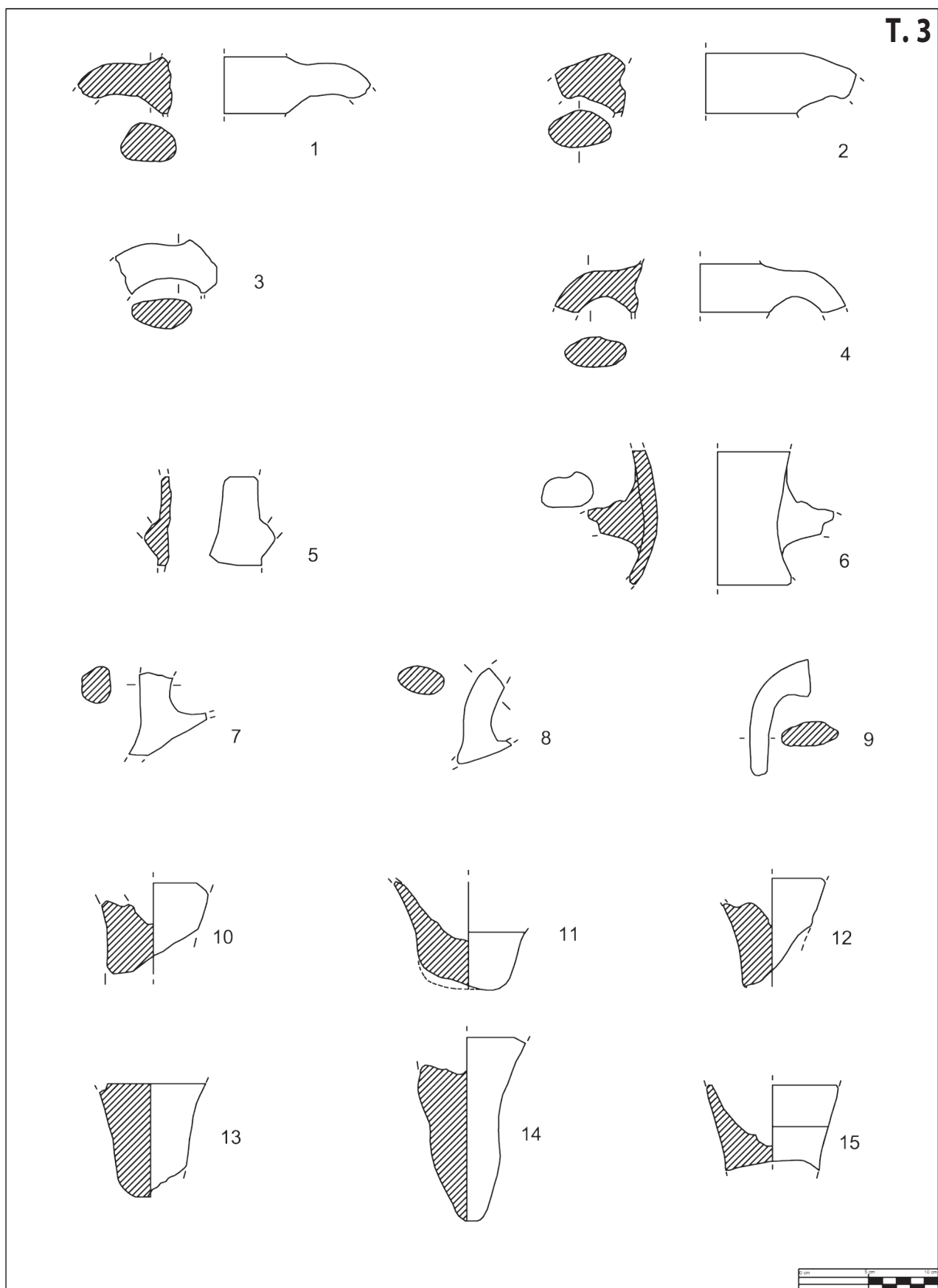

T.3 Afričke amfore – ručke i dna (crteže izradila: A. Konestra)

Pl.3 African amphorae – handles and bases (drawings by A. Konestra)

T.4

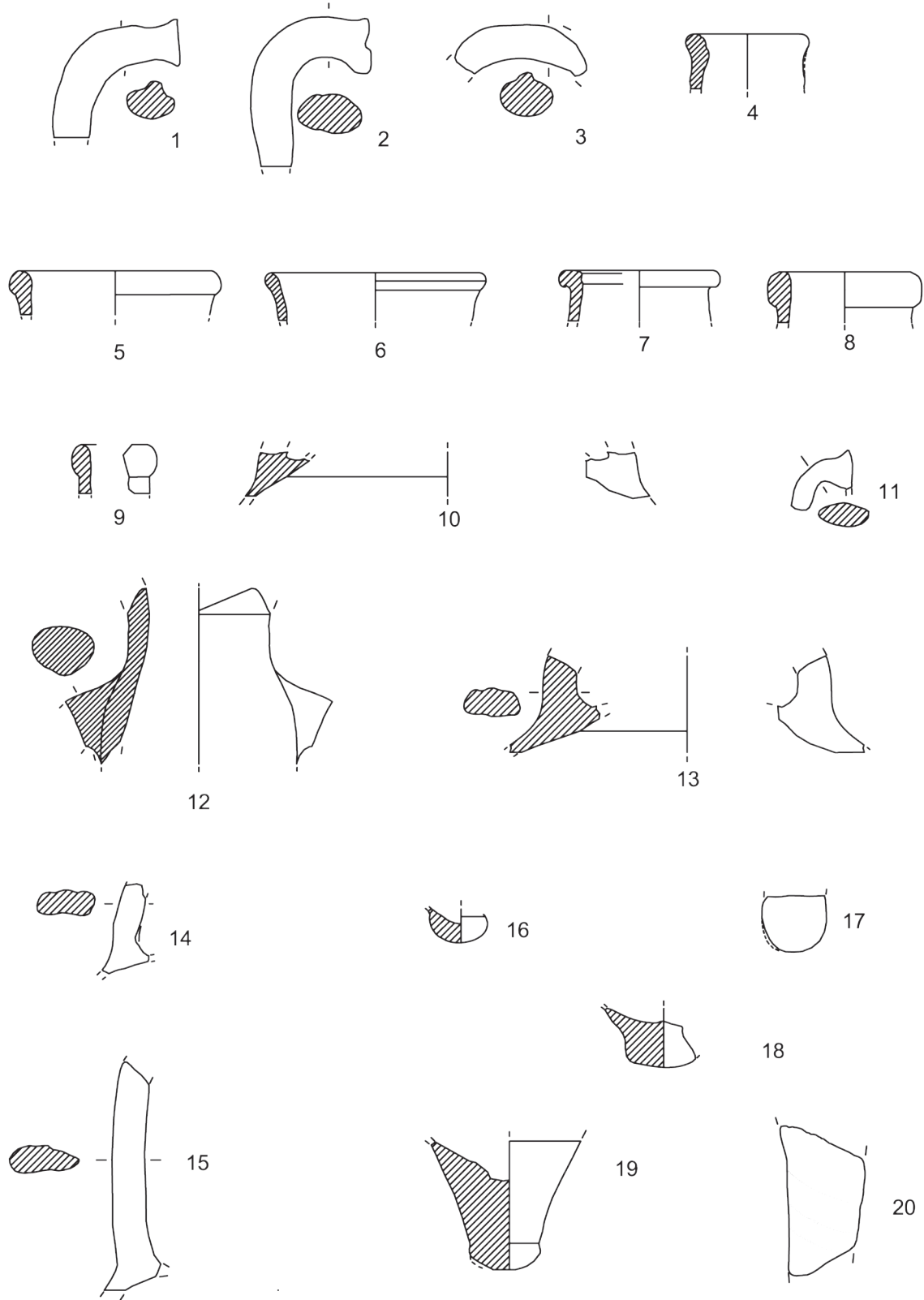

T. 4 Neidentificirane amfore (crteže izradila: A. Konestra)

Pl. 4 Indeterminate amphorae (drawings by A. Konestra)

T. 5

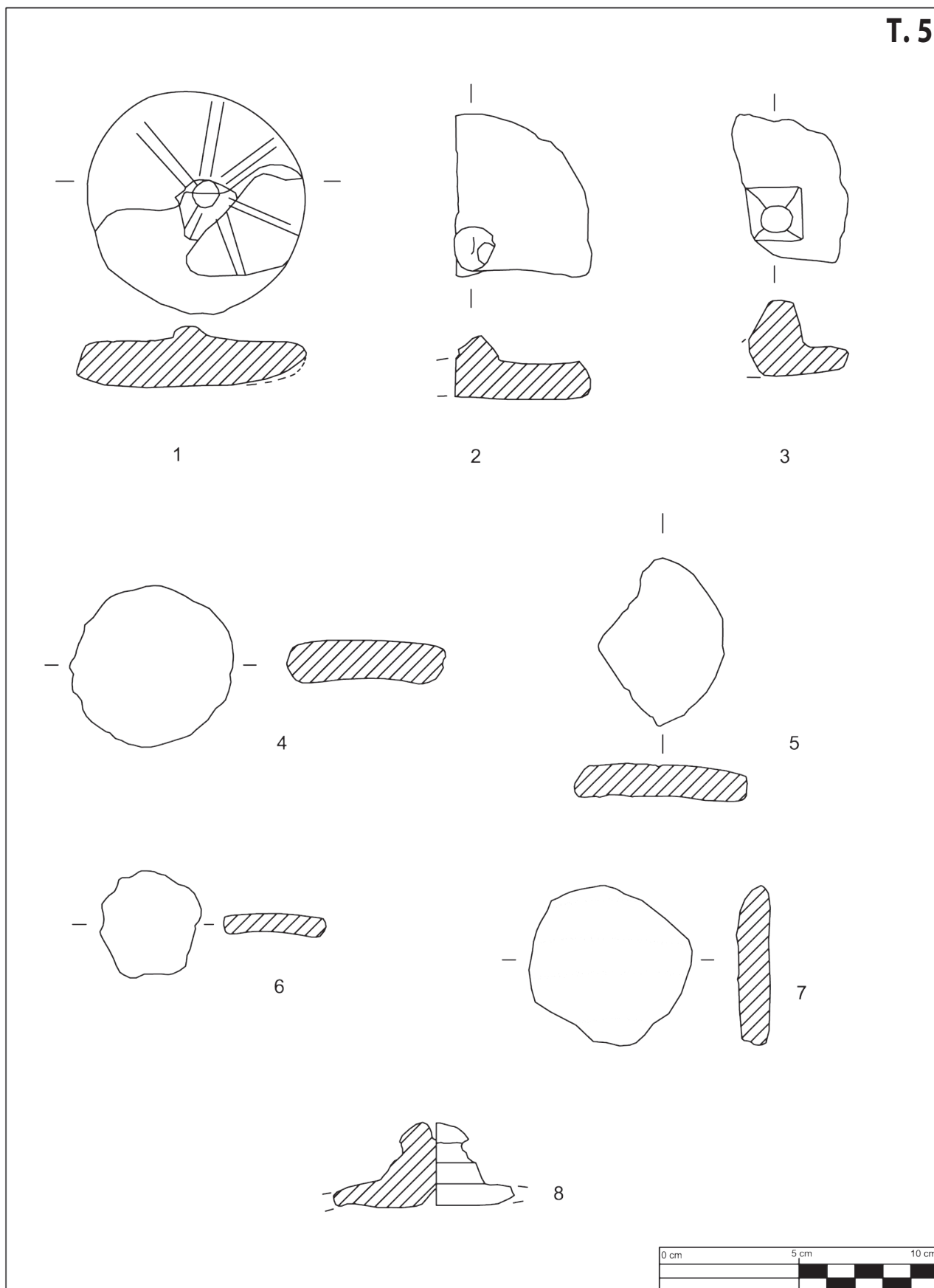

T. 5 Čepovi za amfore (crteže izradila: A. Konestra)

Pl. 5 Amphorae stoppers (drawings by A. Konestra)

T. 6

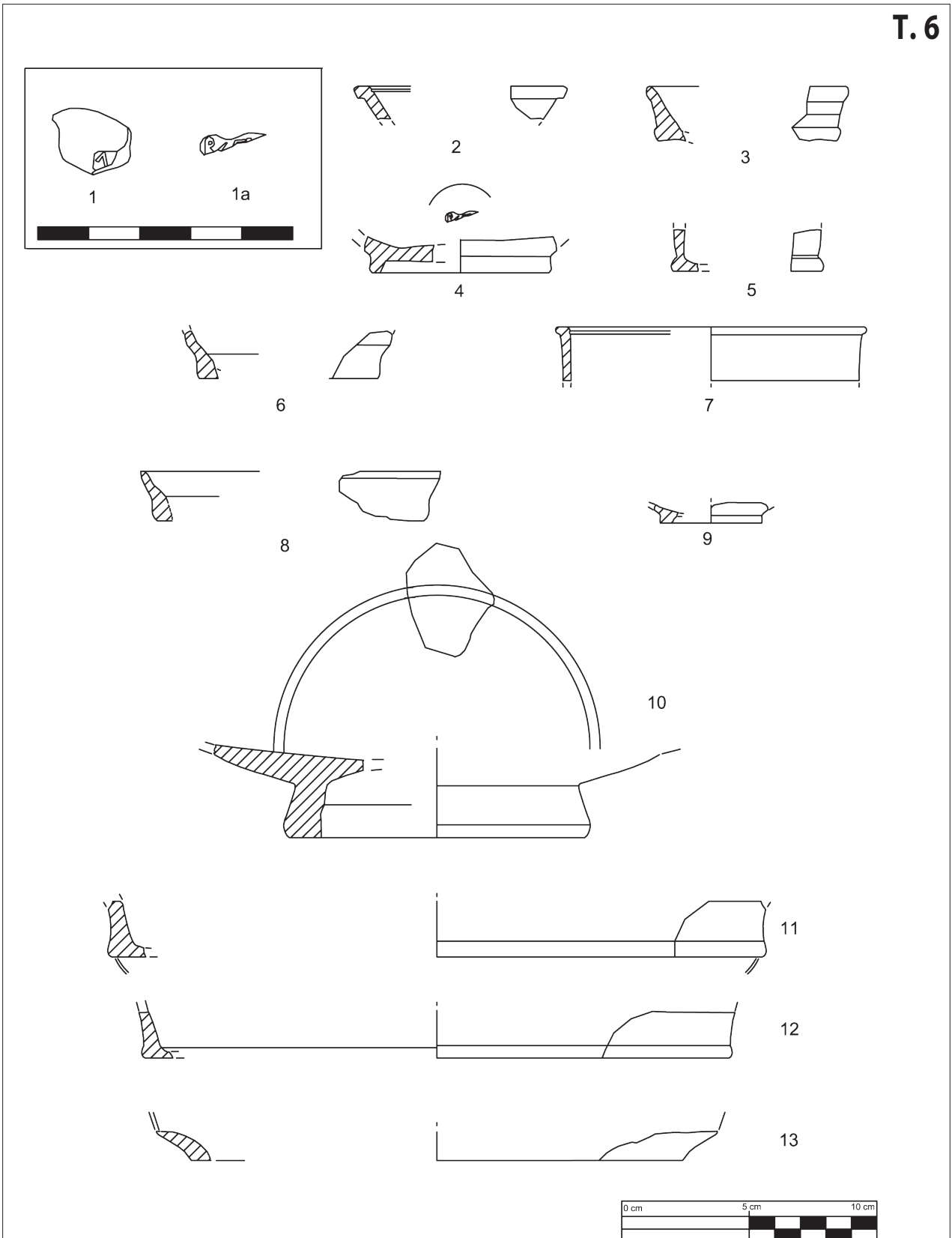

T. 6 Italska terra sigillata (crteže izradila: A. Konestra)

Pl. 6 Italic terra sigillata (drawings by A. Konestra)

T. 7

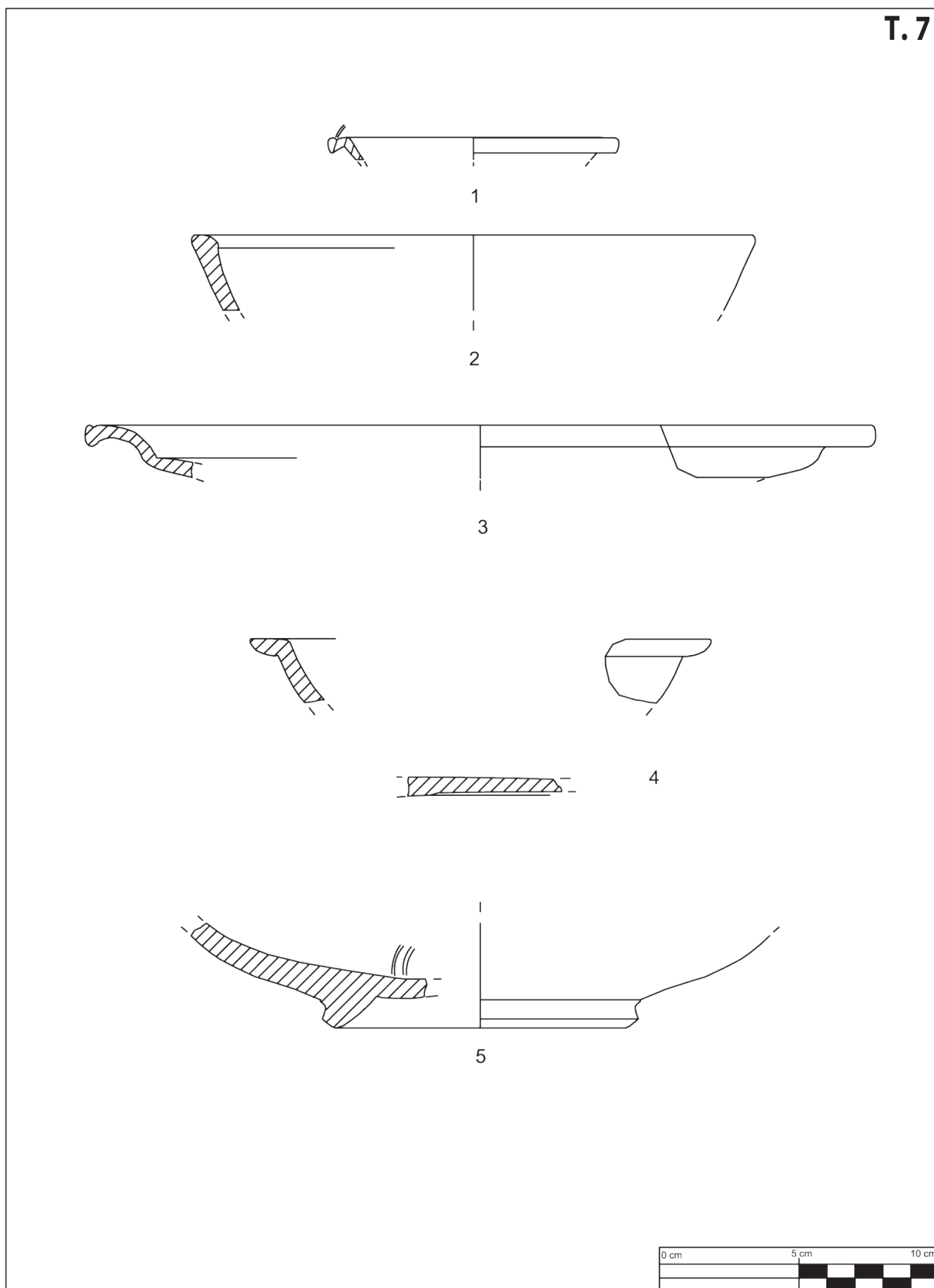

T. 7 Eastern sigillata B (1), afrička sigilata (2–4), galska sigilata (5) (crteže izradila: A. Konestra)

Pl. 7 Eastern sigillata B (1), African sigillata (2–4), Gaulish sigillata (5) (drawings by A. Konestra)

T. 8

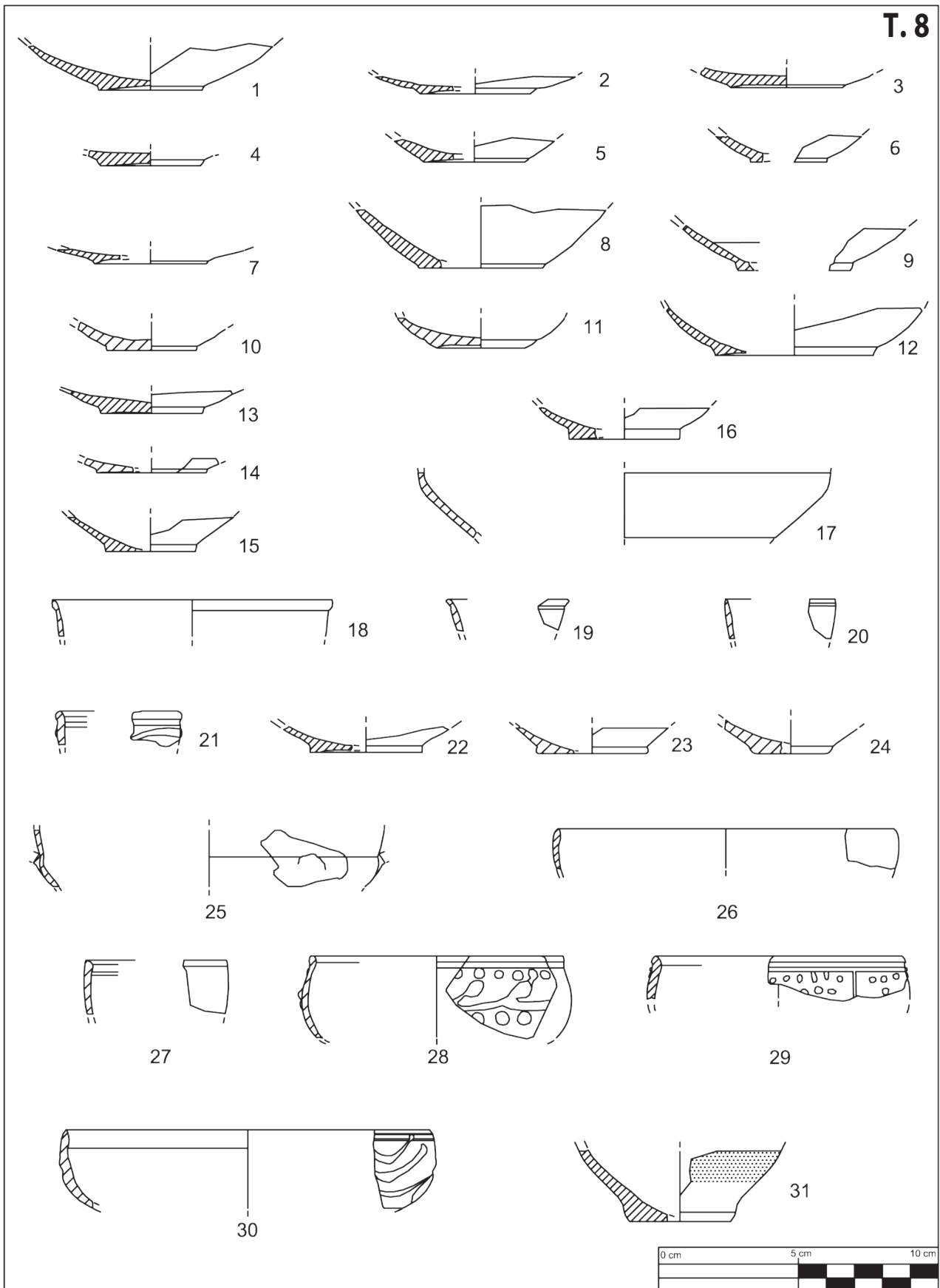

T. 8 Keramika tankih stijenki (crteže izradila: A. Konestra)

Pl. 8 Thin-walled pottery (drawings by A. Konestra)

T. 9

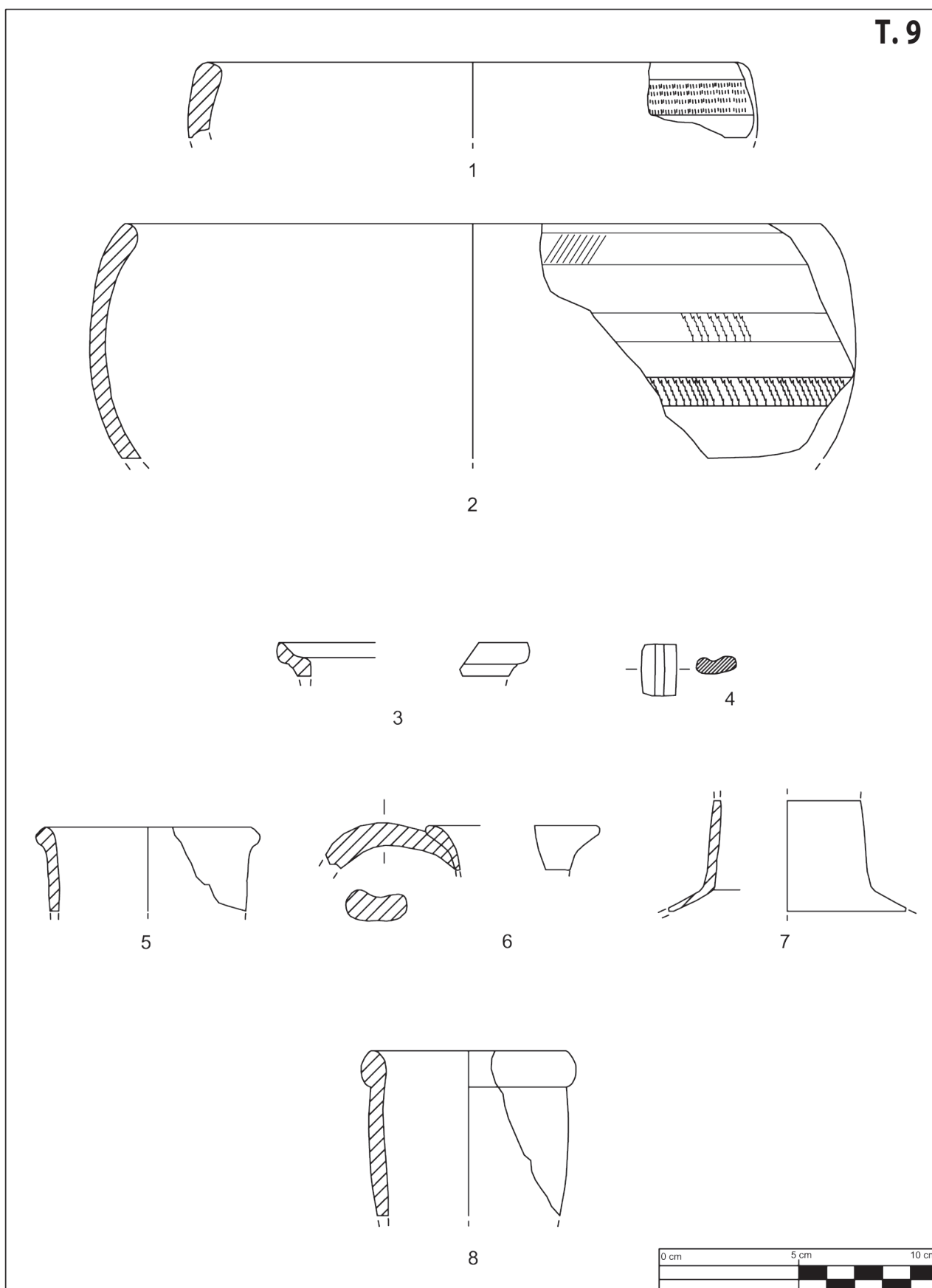

T. 9 Pannonische Glanztonware (1–2), antička glazirana keramika (3–4), kućanska keramika: posude za pohranu i serviranje tekućina (5–8) (crteže izradila: A. Konestra)

Pl. 9 Pannonische Glanztonware (1–2), antička glazirana keramika (3–4), kućanska keramika: posude za pohranu i serviranje tekućina (5–8) (crteže izradila: A. Konestra)

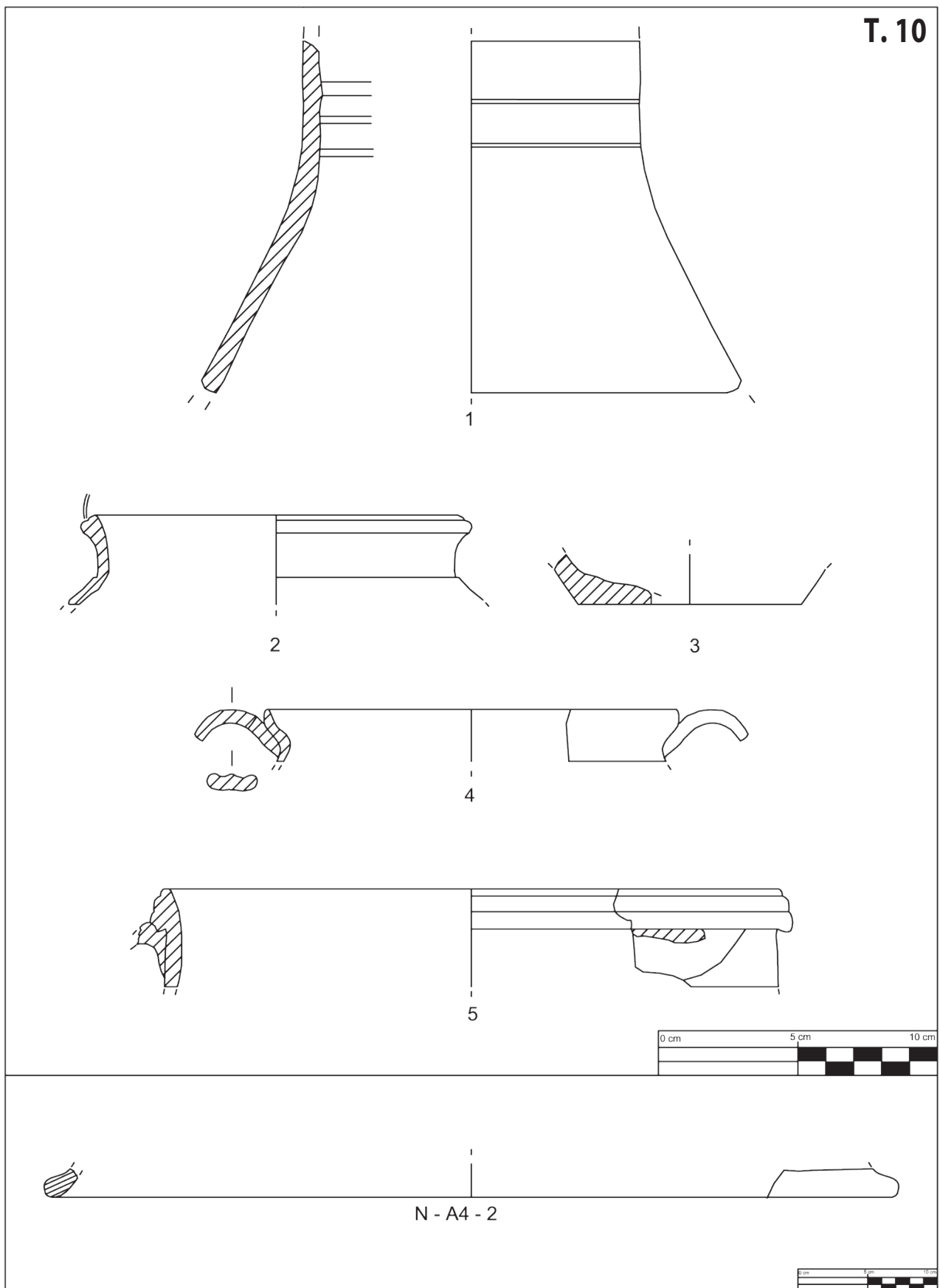

T. 10 Kućanska keramika: posude za pohranu i serviranje tekućina (1), lonci (2–4), zdjele (5), poklopci (6) (crteže izradila: A. Konestra)
 Pl. 10 Domestic ware: pots for storing and serving liquids (1), jars (2–4), bowls (5), lids (6) (drawings by A. Konestra)

T. 11

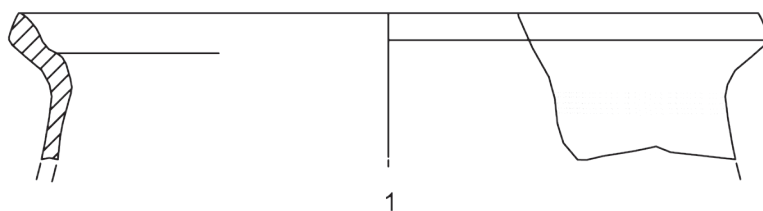

1

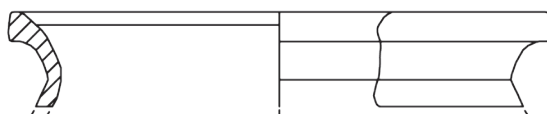

2

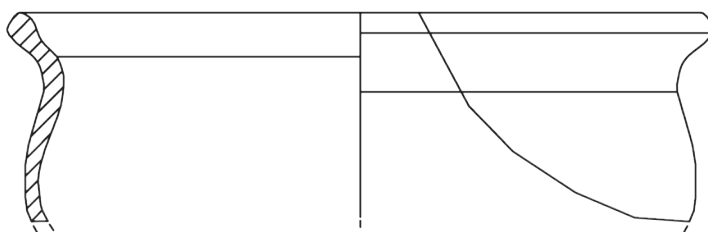

3



4

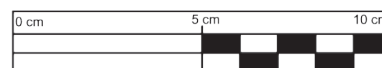

TIP 1

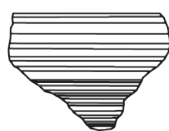

TIP 2



TIP 3



TIP 4

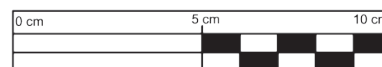
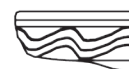

T. 11 Kuhinjska keramika: lonci ranije datacije (1–4), tipologija ukrasa na gruboj keramici (tab. 27) (crteže izradila: A. Konestra)
 Pl. 11 Cooking ware: early jars (1–4), typology of decorations on coarse pottery (Tab. 27) (drawings by A. Konestra)

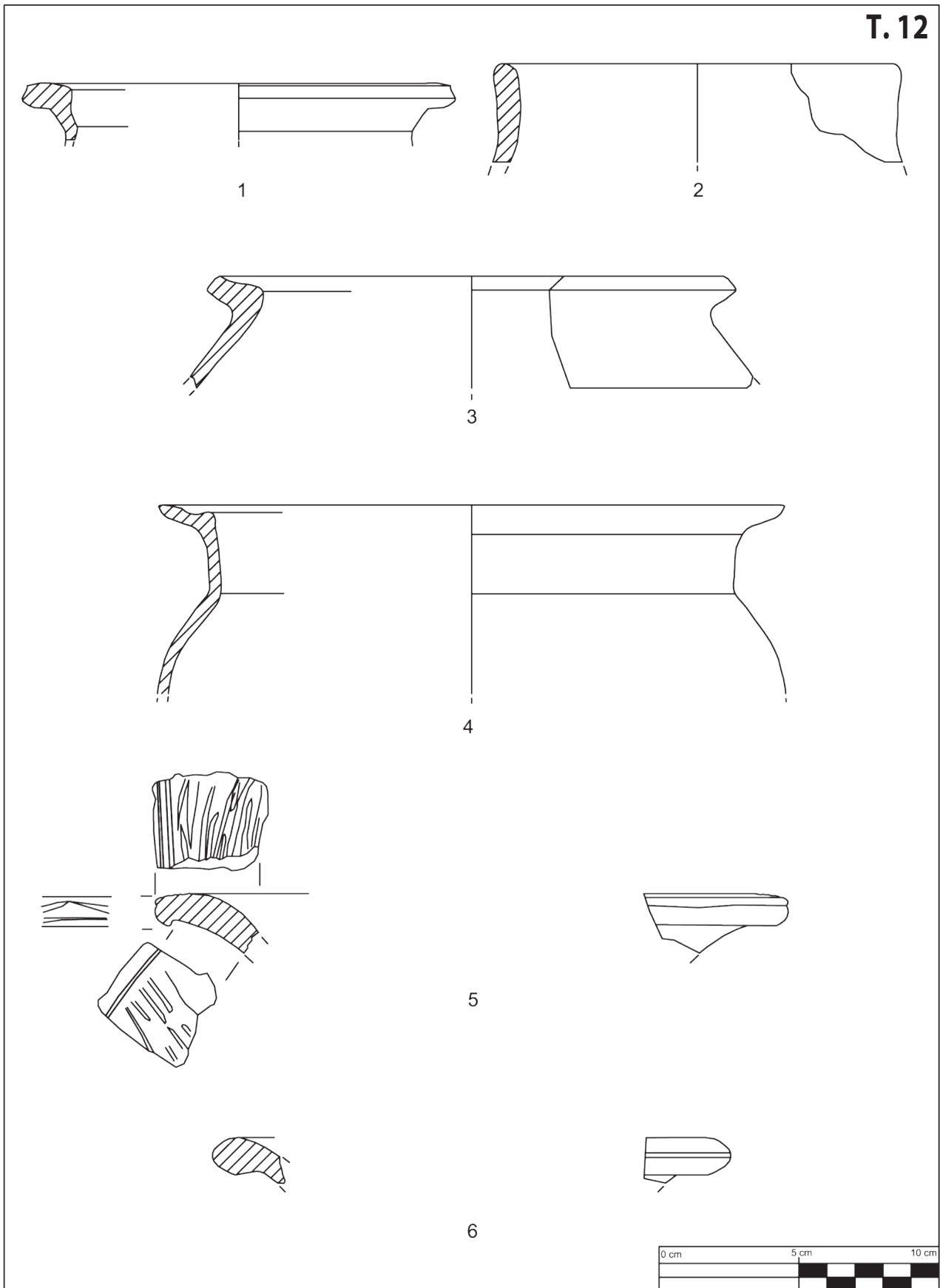

T. 12 Kuhinjska keramika: lonci kasnije datacije (crteže izradila: A. Konestra)

Pl. 12 Cooking ware: latter jars (drawings by A. Konestra)

T. 13

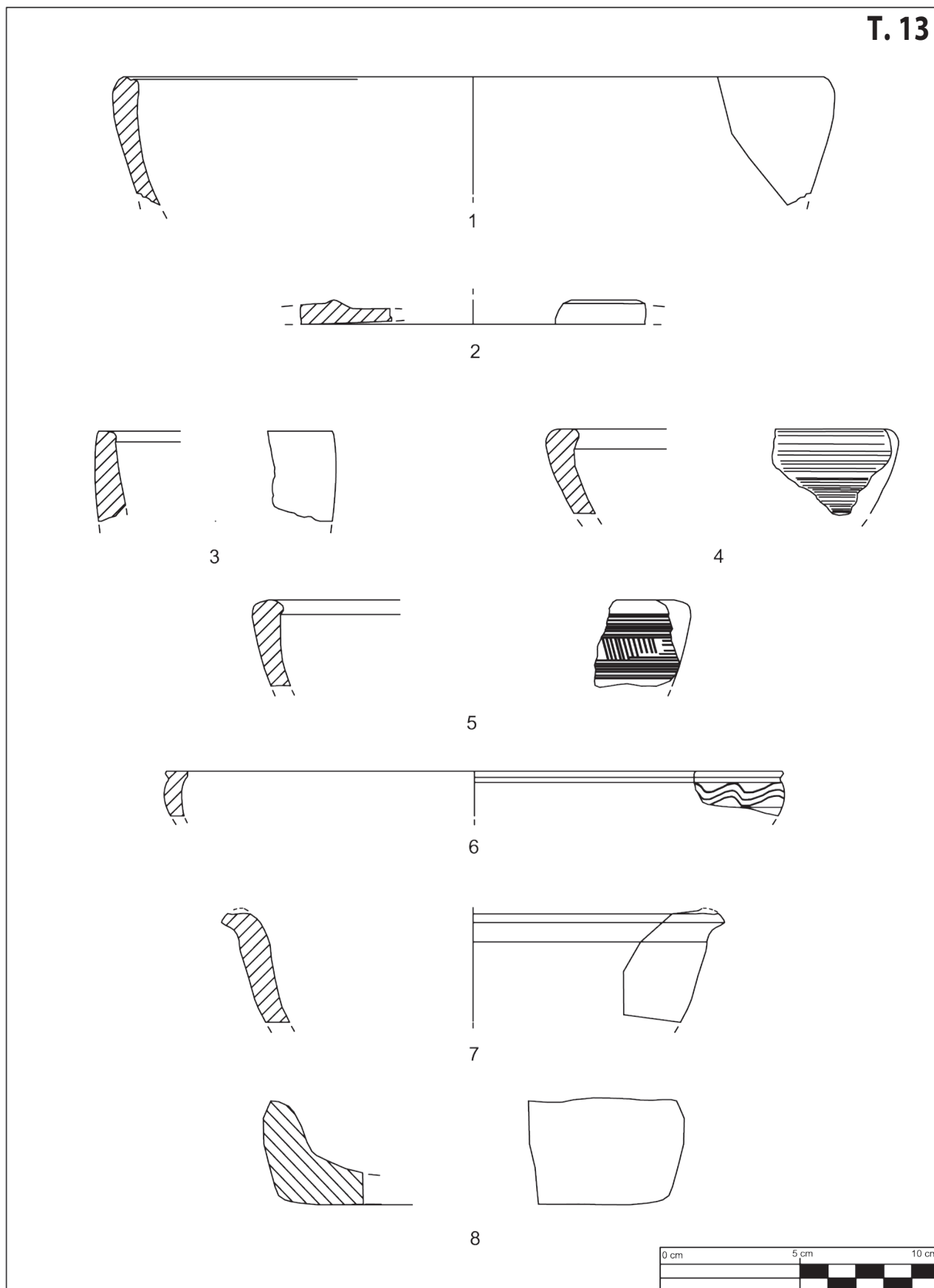

T. 13 Kuhinjska keramika: tave (1–7), pladanj-pekač (8) (crteže izradila: A. Konestra)
Pl. 13 Cooking ware: pans (1–7), baking plate (8) (drawings by A. Konestra)

T. 14

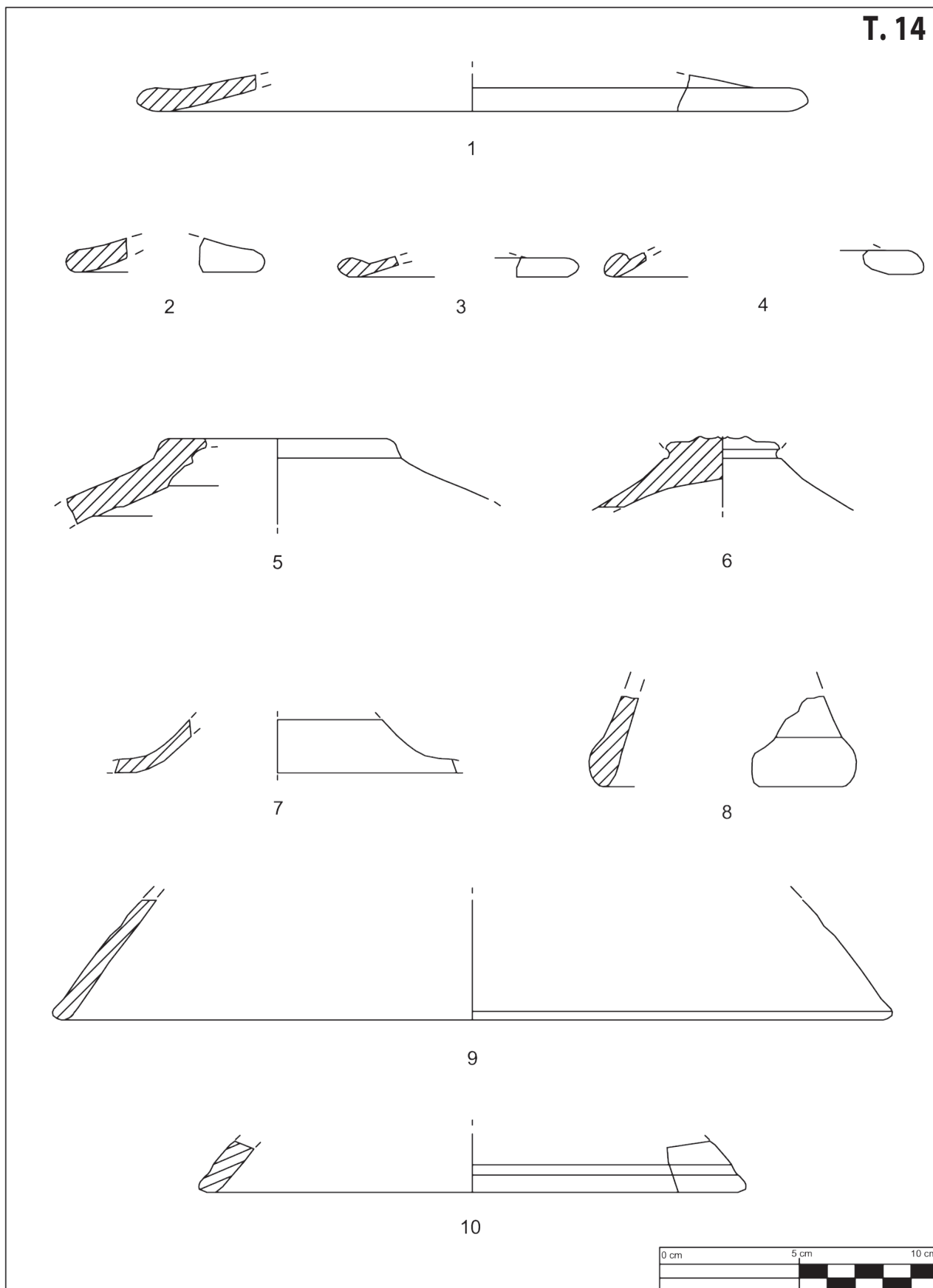

T. 14 Kuhinjska keramika: poklopci (crteže izradila: A. Konestra)
Pl. 14 Cooking ware: lids (drawings by A. Konestra)

T. 15

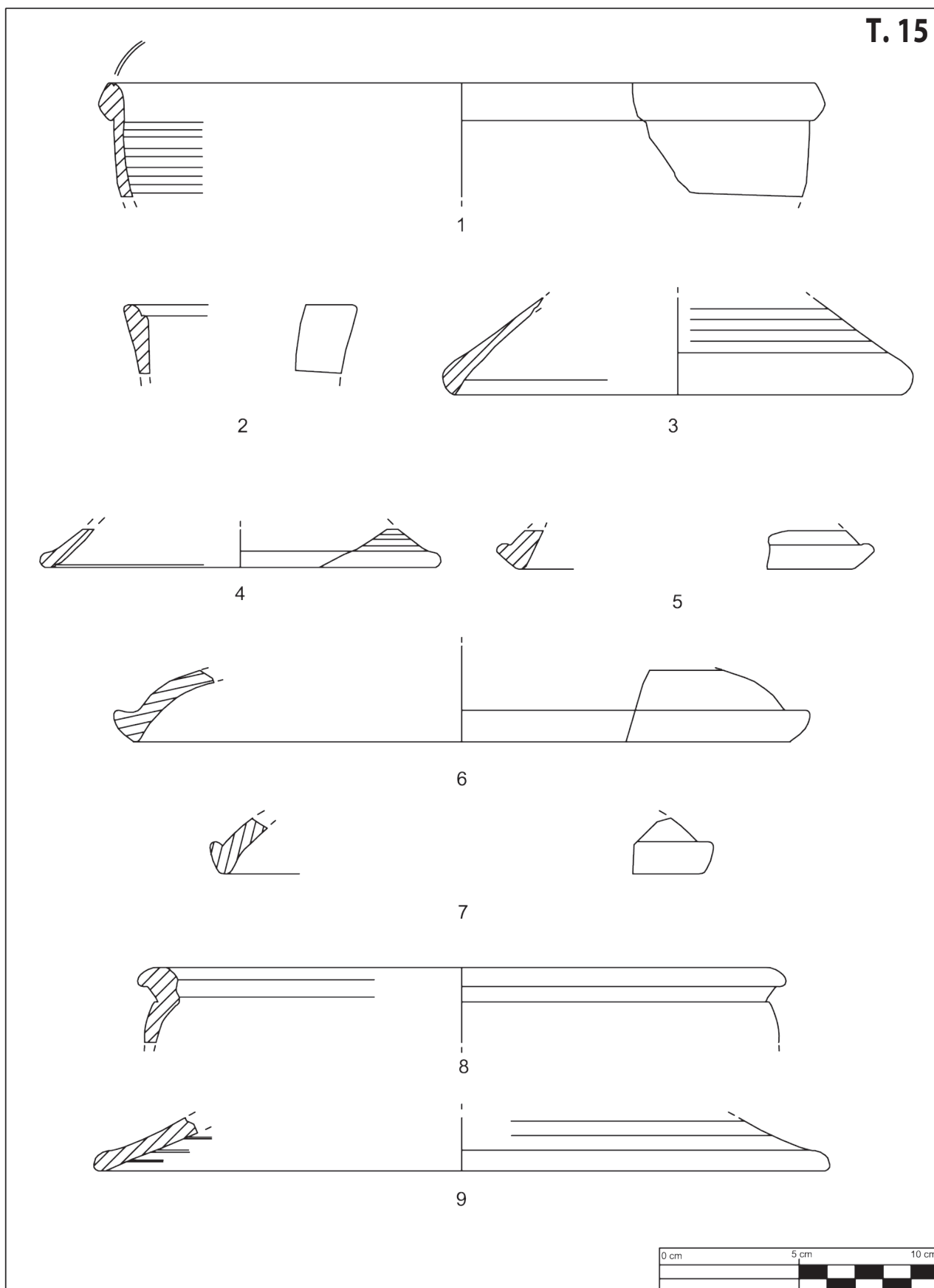

T. 15 Kuhinjska keramika: afrička kuhinjska keramika (1–7), keramika upitne provenijencije (8–9) (crteže izradila: A. Konestra)
Pl. 15 Cooking ware: African cooking ware (1–7), pottery of dubious origin (8–9) (drawings by A. Konestra)

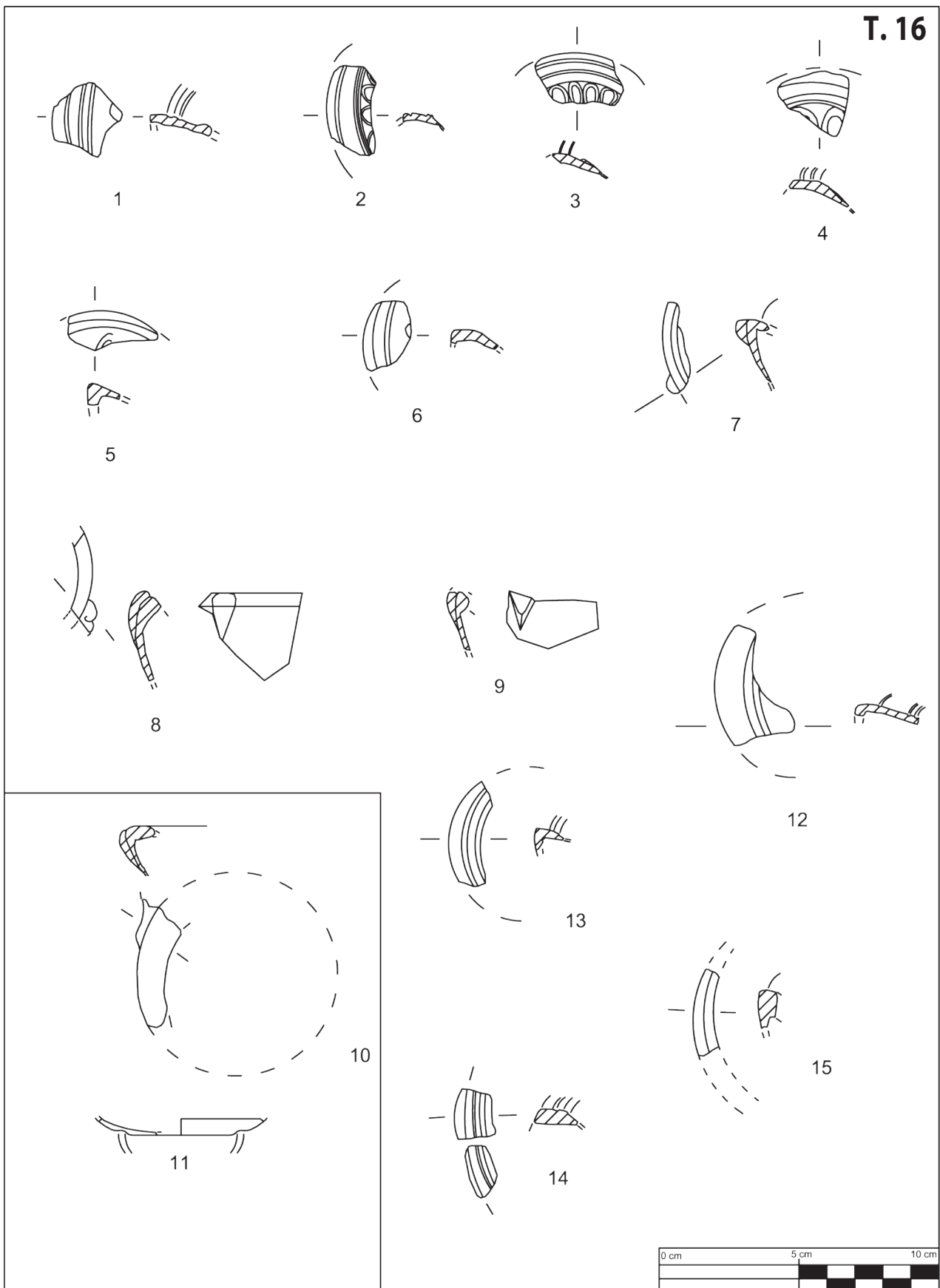

T. 16 Keramičke uljanice (crteže izradila: A. Konestra)

Pl. 16 Ceramic oil lamps (drawings by A. Konestra)

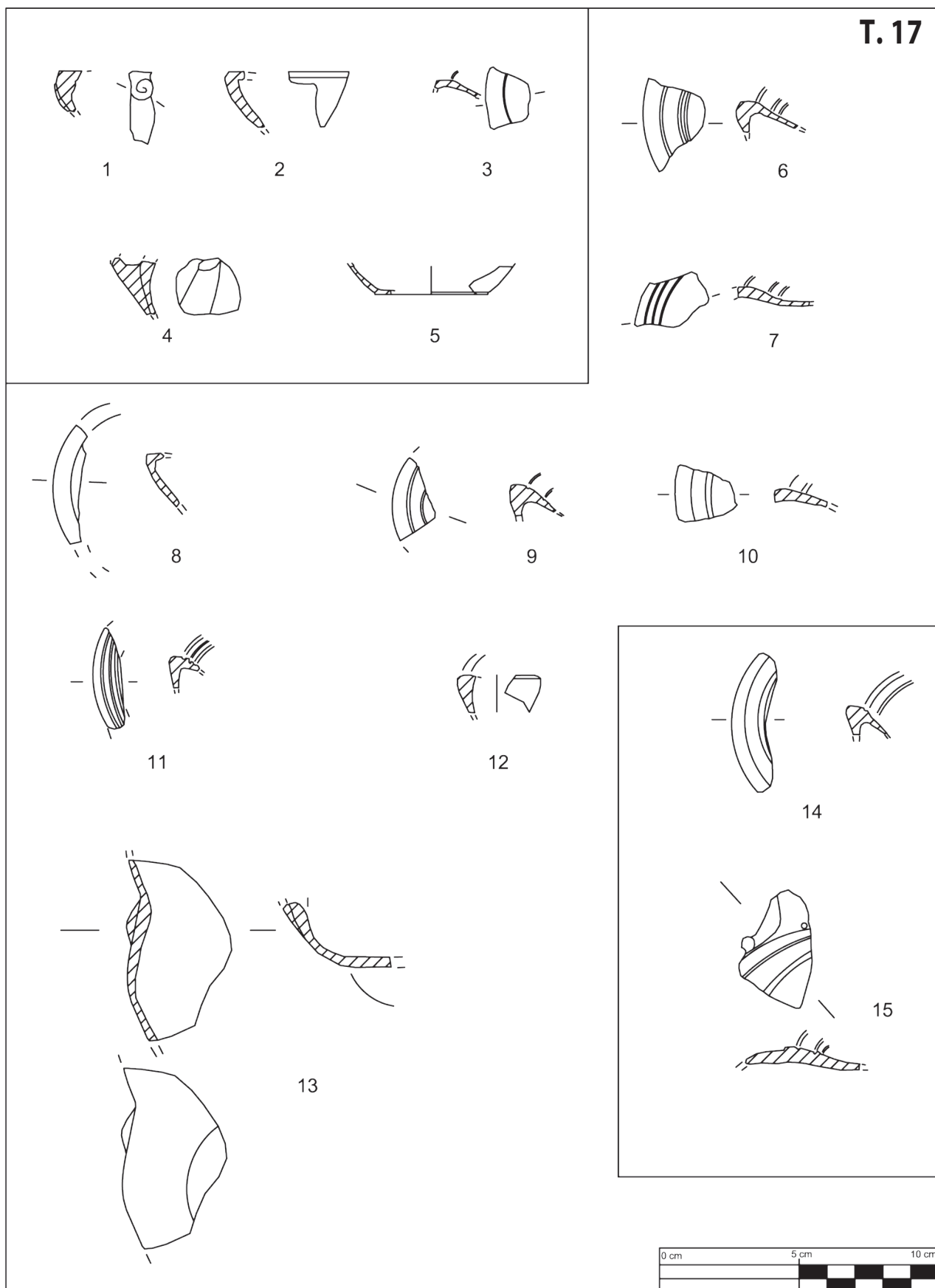

T. 17 Keramičke uljanice (crteže izradila: A. Konestra)
 Pl. 17 Ceramic oil lamps (drawings by A. Konestra)

T. 18

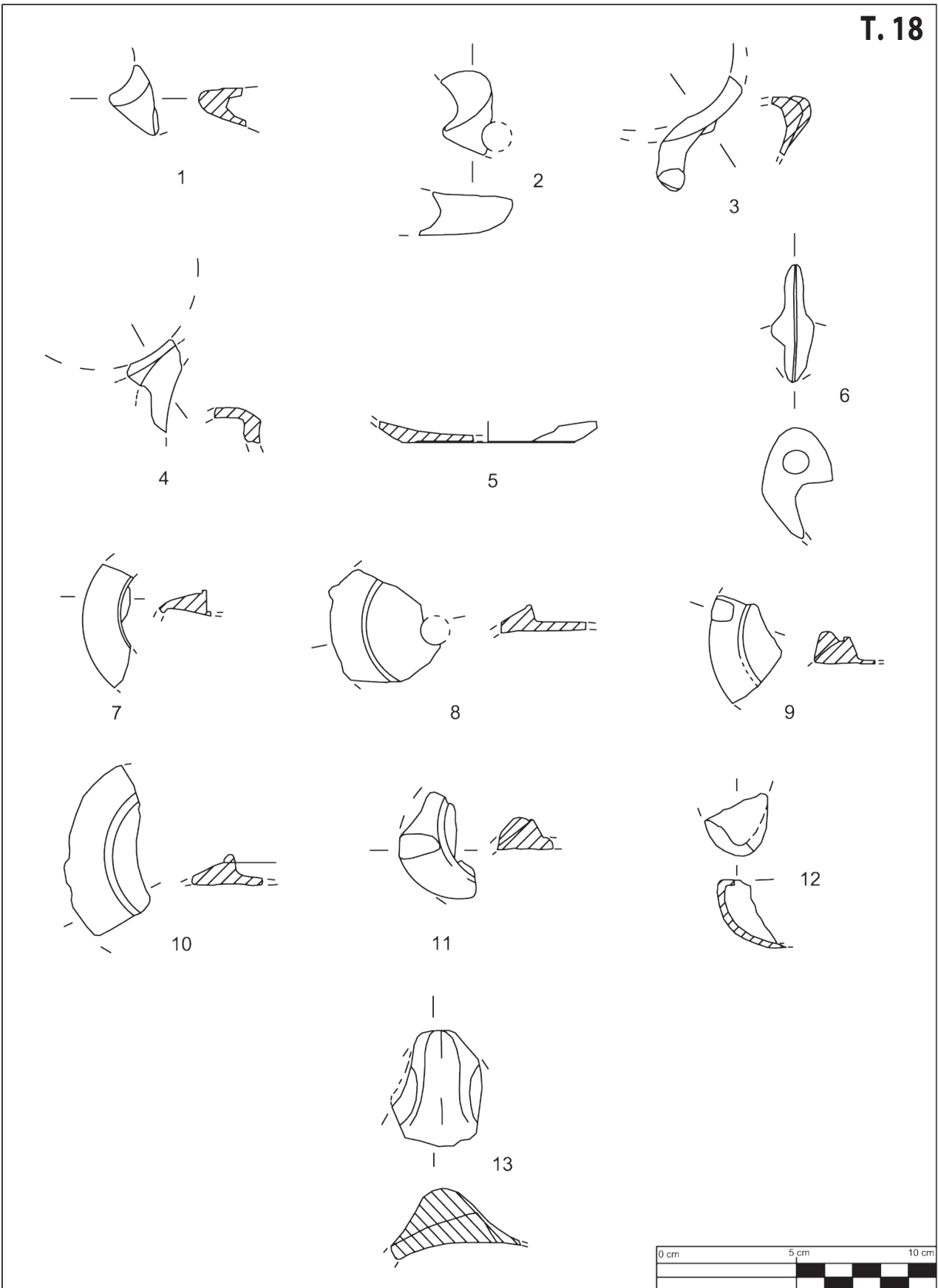

T. 18 Keramičke uljanice (crteže izradila: A. Konestra)
Pl. 18 Ceramic oil lamps (drawings by A. Konestra)

T. 19

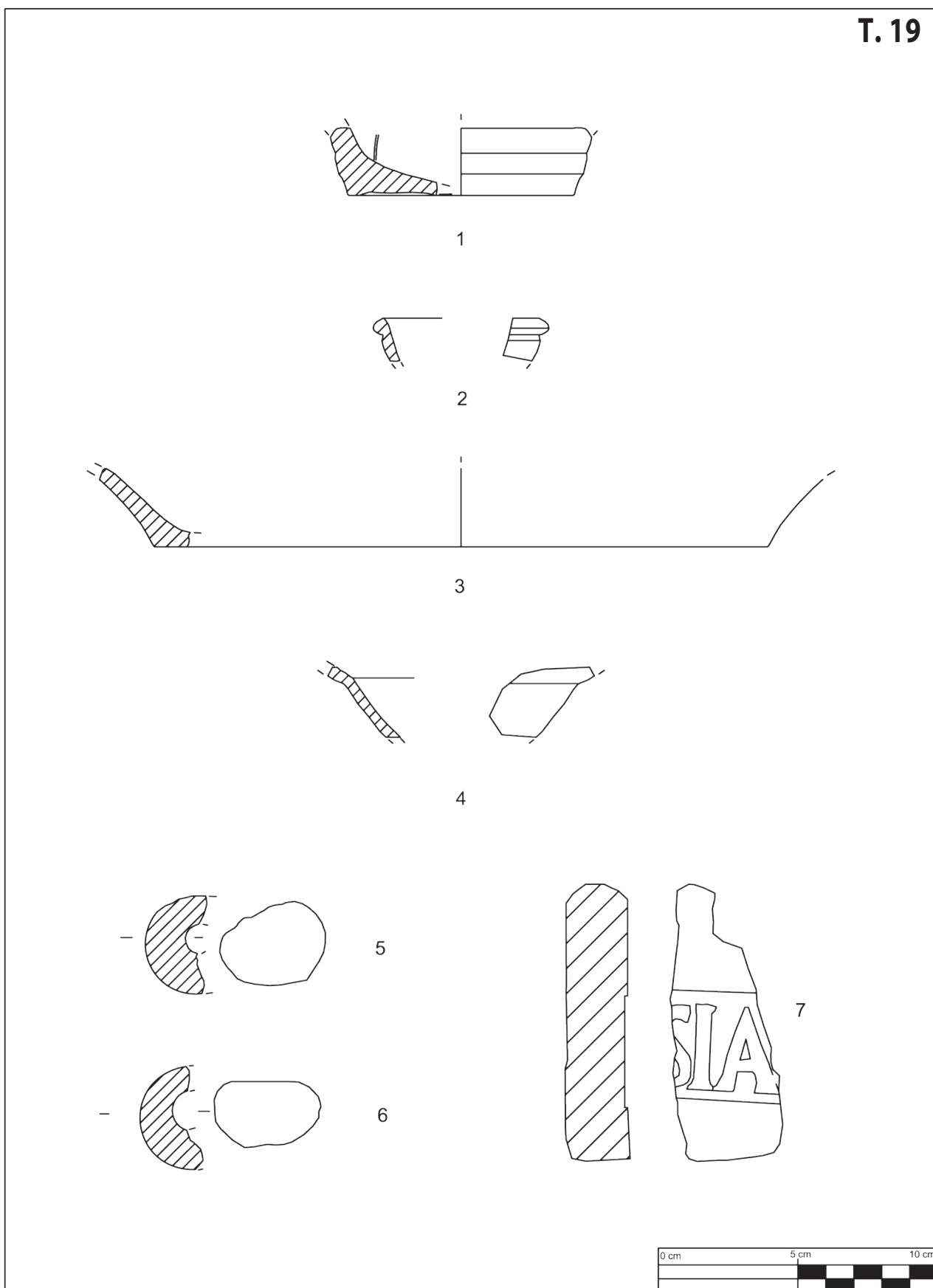

T. 19 Novovjekovna keramika (1–4), utezi za mrežu (5–6), tegula s pečatom (7) (crteže izradila: A. Konestra)

Pl. 19 Modern period pottery (1–4), fishing net weights (5–6), stamped tegula (7) (drawings by A. Konestra)