

## 3D OBLIKOVANJE I PRORAČUN KUĆIŠTA VIJČANE PUMPE

### 3D DESIGN AND CALCULATION OF A SCREW PUMP HOUSING

*Božidar Hršak, Ante Čikić, Tajana Vaško, Igor Čusek*

Stručni članak

**Sažetak:** Prikazano je 3D oblikovanje i proračun kućišta trovretene vijčane pumpe na temelju postojeće 2D radioničke dokumentacije u lijevanoj izvedbi. Izrađen je kontrolni proračun debljine stjenke kućišta trovretene vijčane pumpe za materijale SL-25, NL-42, AlSiMg i ispitni tlak 1,5 MPa (15 bara). Svi 3D modeli pozicija, sklop i "generirana" 2D radionička dokumentacija izrađeni su u programskom alatu SolidWorks naprednim tehnikama 3D oblikovanja. U programskom modulu Solidworks Simulation provedene su analize naprezanja kućišta trovretene vijčane pumpe Finite Element Analysis – FEA za materijale: SL-25, NL-42 i AlSiMg koje su potvrdile točnost provedenog kontrolnog proračuna, te analiza toka strujanja fluida u 3 modelu sklopa trovretene vijčane pumpe. Pomoću 3D pisaača MakerBot Replicator 2X primjenom FDM tehnologije taložnog očvršćivanja materijala izrađen je umanjeni 3D model sklopa trovretene vijčane pumpe. Istaknuta je praktična primjenjivost unapređenja i razvoja vijčanih pumpi.

**Ključne riječi:** Analiza naprezanja kućišta, analiza toka strujanja fluida, kućište trovretene vijčane pumpe, proračun debljine stjenke kućišta, 2D radionička dokumentacija, 3D oblikovanje

Professional paper

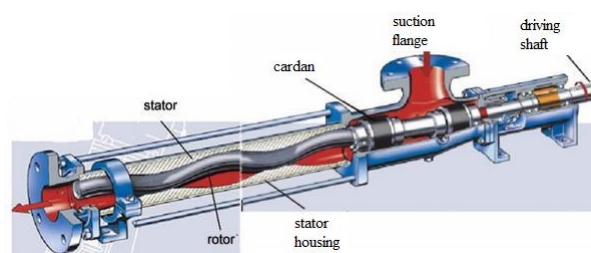
**Abstract:** Shown is the 3D design and calculation of a three-spindle screw pump housing based on existing 2D workshop documentation of a cast version of the housing construction. A control calculation of the thickness of the wall of the housing of the three-spindle screw pump has been made for materials SL-25, NL-42, AlSiMg and test pressure of 1,5 MPa (15 bars). Each 3D model of positions, assemblies and generated 2D workshop documentation are made in the software tool SolidWorks with advanced techniques of 3D modelling. In the software module SolidWorks Simulation stress analysis of the housing of a three-spindle screw pump was performed, that is, Finite Element Analysis – FEA for materials SL-25, NL-42 and AlSiMg, that confirmed the accuracy of the calculations made, and the analysis of the fluid flow of the 3D model of the assembly of the three-spindle screw pump. With help of the 3D printer MakerBot Replicator 2X with application of FDM technology of sedimentary hardening of materials, a miniature 3D model of the assembly of the three-spindle screw pump was created. The practical application of the improvement and development of screw pumps is emphasized.

**Key words:** Stress analysis of housing, Fluid flow analysis, Housing of a three-spindle screw pump, Calculation of wall thickness of housing, 2D workshop documentation, 3D modelling

## 1. INTRODUCTION

The application of screw-like machine elements for medium flow is dating from the third century B.C. and is attributed to the Greek philosopher Archimedes. Screw pumps of simple construction with a screw positioned inside a pipe were used for pumping water out of canals with the purpose of watering. Today, screw pumps with one, two or three spindles are produced and only have one driving shaft, while the synchronous rotational speed in two-spindle pumps is achieved with a pair of the same gear wheels, whereas in three-spindle pumps with the pressure of the working medium. Inside one-spindle screw pumps, alteration of the volume of the working space is established with periodical changes of the space between the inner wall of the housing and the rotor, while the rotor is spinning [1].

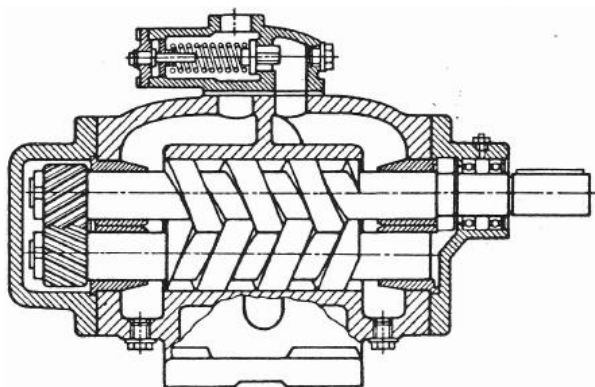
One-spindle screw pump (Figure 1.) has only one rotating element, and is mostly used in pharmacy, food and chemical industry.



**Figure 1.** One-spindle screw pump [2]

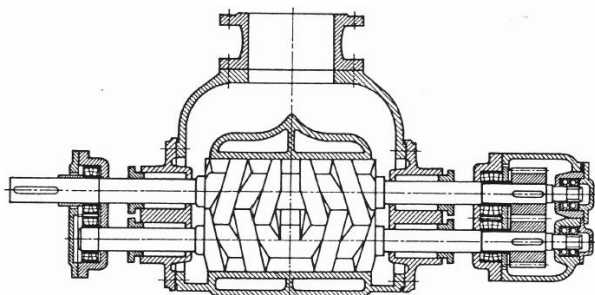
Two-spindle screw pumps are divided into one-flow and two-flow pumps. This pump drives the medium away in one axial direction, just as the one-spindle screw pump.

On Figure 2. the one-flow two-spindle screw pump is shown.



**Figure 2.** One-flow two-spindle screw pump [1]

The two-flow two-spindle screw pump (Figure 3.) separates the medium in the suction box into two parts that are lead off to the outer parts of the pump screws. With the spinning of the screws, the part of the medium that was lead off to the left side, is driven from the left to the centre of the pump, where it is brought together with the part that was driven to the right at the suction box, and is lead out of the screw pump through the flange.



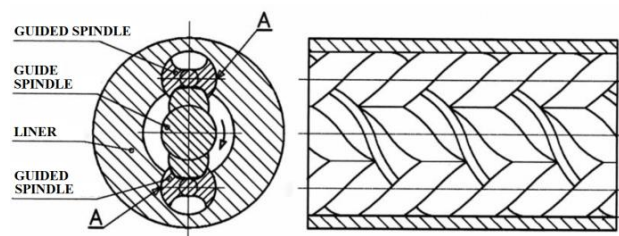
**Figure 3.** Two-flow two-spindle screw pump [1]

With the goal of optimisation of the existing product, the control calculation of the wall thickness of the housing is shown for the test pressure 1,5 MPa (15 bars) and housing materials SL-25, NL-42, and AlSiMg, and 3D modelling of parts and assembly of a three-spindle screw pump based on existing 2D documentation of a cast version of the housing construction. Applying reverse engineering, in the software tool *SolidWorks*, a 3D model of the assembly of the three-spindle screw pump is created, with all the positions, and with the *Exploded View* feature, the exploded 3D model of the three-spindle screw pump is displayed. In the software module *SolidWorks Simulation*, stress analysis (*Finite Element Analysis – FEA*) and safety factor analysis (*Factor Of Safety - FOS*) are performed for the housing of the pump at the test pressure 1,5 MPa (15 bars) and materials: SL-25, NL-42 and AlSiMg, and the analysis of the fluid flow of the 3D model of the assembly of the three-spindle screw pump.

## 2. THREE-SPINDLE SCREW PUMP

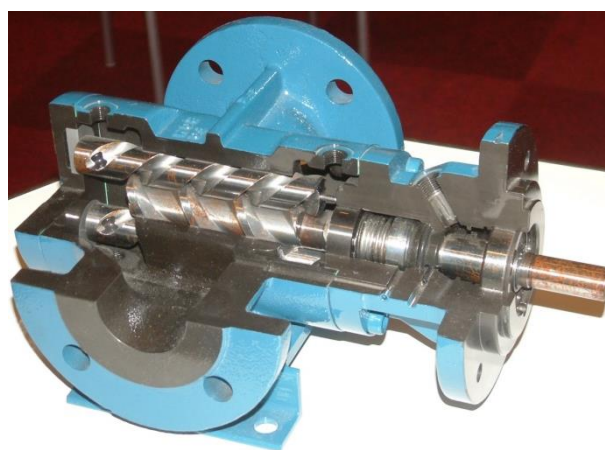
The three-spindle screw pump contains three spindles, of which one is the guide spindle, and the other two are guided. The guide and guided spindles are positioned inside the liner in which they rotate and form transporting chambers. With the rotation of the spindles, the helices close the transporting chambers, take hold of the medium in the suction box, and continuously „drag“ the medium along the spindle axis and push it into the pressure chamber of the housing of the pump. The helices of the spindles are two-stroked and their surface is designed so that it ensures fine sealing between the guide and guided spindles, and between the spindles and liner. The guide spindle transfers the load and is mostly driven by electro- or pneumatic motor, while the guided spindles hinder the back flow of the liquid from the pressure chamber into the suction chamber and are used for sealing inside the pump [3].

Figure 4. displays the schematic view of the spindles inside the liner of the three-spindle screw pump.



**Figure 4.** Schematic view of the spindles inside the liner of the three-spindle screw pump [3]

Three-spindle screw pumps are designed in an „H“ construction with the input and output on the same axes, or „S“ construction with the input and output on parallel axes [4]. Also, they can be constructed horizontally (Figure 5.) or vertically (Figure 6.).



**Figure 5.** Cross-section of a horizontal construction of the three-spindle screw pump [5]



**Figure 6.** Vertical construction of the three-spindle screw pump [6]

Three-spindle screw pumps are used as transfer or fuel dosing pumps, oil pumps, oil pumps in main or auxiliary motors, oil and fuel separators, and as hydraulic system pumps for pressures up to 8 MPa [3]. Media in the pumps are gasoline and heavy fuel oils, lubricants and hydraulic oils, and other self-lubricating and nonaggressive fluids.

The flow rate of three-spindle screw pumps totals 50 to 560 litres per minute, while the working temperature goes from 20 to 180 °C with the working pressure of 10 bars [4].

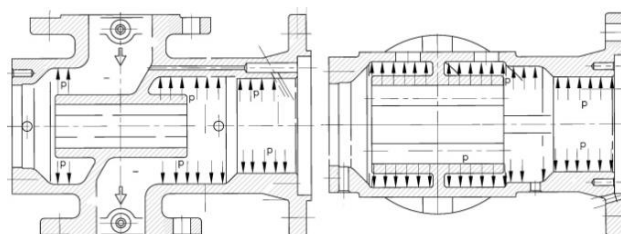
Table 1. displays common characteristics of one-, two-, and three-spindle screw pumps.

**Table 1.** Common characteristics of one-, two- and three-spindle screw pumps [7]

Pump type	Desirable application	Common characteristics
One-spindle screw pump	Fluids that contain solids	Self-priming Good suction capacity
Two-spindle screw pump	Fluids with or without lubricating characteristics, Fluids that contain air or gas	Not sensitive to viscosity Weak pulsation Almost noiseless functioning
Three-spindle screw pump	Media with lubricating characteristics, high pressure and noiseless functioning	Safe handling Low susceptibility to dirt

### 3. CONTROL CALCULATION OF THE WALL-THICKNESS OF THE HOUSING OF THE THREE-SPINDLE SCREW PUMP

Based on the existing 2D workshop documentation for a cast construction, a control calculation of the wall-thickness of the housing of the three-spindle screw pump is performed for the test pressure of 1,5 MPa (15 bars) and housing materials: SL-25 , NL-42 and AlSiMg.



**Figure 7.** Housing of the three-spindle screw pump

Test pressure 1,5 MPa (15 bars) and housing material of the three-spindle screw pump SL – 25 [8]:

$$\delta_o = \frac{p \cdot d}{200 \cdot \sigma_{dop}} \quad \text{mm}, \quad (1)$$

$$C = 6 \cdot \left(1 - \frac{p \cdot d}{27500}\right) \quad \text{mm}, \quad (2)$$

$$\delta = \delta_o + C \quad \text{mm}, \quad (3)$$

whereat:

$\delta_o$  - theoretical thickness of the housing wall, = 1,50 mm,

$\delta$  - real thickness of the housing wall, = 7,11 mm,

$p$  - test pressure, = 15 kp/cm<sup>2</sup>,

$d$  - nominal diameter, = 120 mm,

$\sigma_{dop}$  - allowable stress, = 6 kp/mm<sup>2</sup> SL-25 [9]

$C$  - addition due to inaccuracies in production, = 5,61 mm.

Acquired wall thickness of the pipe of the housing of the tree-spindle screw pump  $\delta = 7$  mm.

Test pressure 1,5 MPa (15 bars) and housing material of the three-spindle screw pump NL – 42 [8]:

Relations (1), (2) and (3) are used, whereat:

$\delta_o$  - theoretical thickness of the housing wall, = 0,97 mm,

$\delta$  - real thickness of the housing wall, = 6,58 mm,

$p$  - test pressure, = 15 kp/cm<sup>2</sup>,

$d$  - nominal diameter, = 120 mm,

$\sigma_{dop}$  - allowable stress, = 9,3 kp/mm<sup>2</sup> NL-42 [9]

$C$  - addition due to inaccuracies in production, = 5,61 mm.

Acquired wall thickness of the pipe of the housing of the tree-spindle screw pump  $\delta = 6,5$  mm.

Test pressure 1,5 MPa (15 bars) and housing material of the three-spindle screw pump AlSiMg [8], according to relations (1), (2) and (3), whereat:

$\delta_o$  - theoretical thickness of the housing wall, = 3 mm,

$\delta$  - real thickness of the housing wall, = 8,61 mm,

$p$  - test pressure, = 15 kp/cm<sup>2</sup>,

$d$  - nominal diameter, = 120 mm,

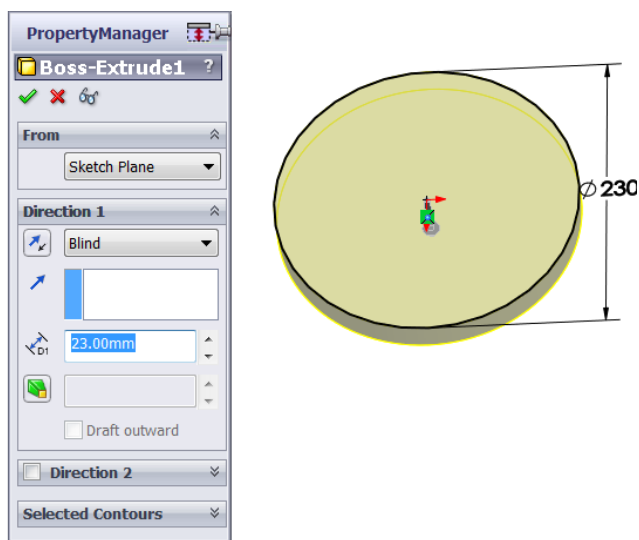
$\sigma_{dop}$  - allowable stress, = 3 kp/mm<sup>2</sup> AlSiMg [9]

$C$  - addition due to inaccuracies in production, = 5,61 mm.

Acquired wall thickness of the pipe of the housing of the tree-spindle screw pump  $\delta = 8,5$  mm.

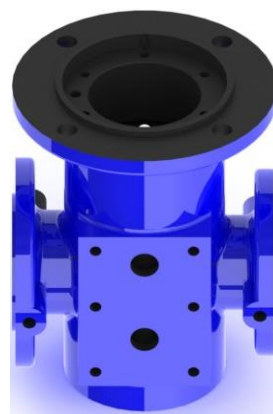
#### 4. CONSTRUCTION OF THE 3D MODEL OF PARTS AND ASSEMBLY OF THE THREE-SPINDLE SCREW PUMP

Based on the existing 2D workshop documentation of the cast version of the housing of the three-spindle screw pump the sketch of the mounting flange with the diameter  $\varnothing 230$  mm is created, and material is added with the *Extruded Boss/Base* feature (Figure 8.).



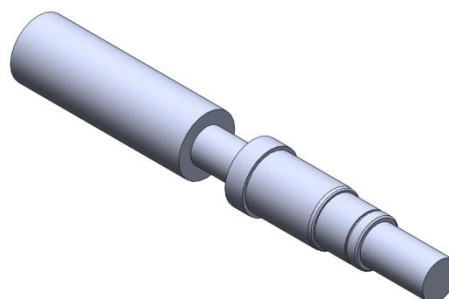
**Figure 8.** 3D modelling of the mounting flange with adding material through the *Extruded Boss/Base* feature

With help of the feature for advanced 3D modelling and the feature for final rendering, the housing of the three-spindle screw pump was created (Figure 9.).



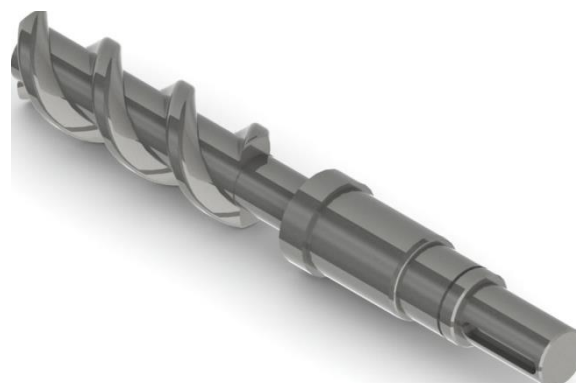
**Figure 9.** Rendered (photorealistic) depiction of the 3D model of the three-spindle screw pump

The process of 3D modelling of the guide spindle of the three-spindle screw pump starts with creating the sketch and adding material with the *Extruded Boss/Base* feature (Figure 10.).

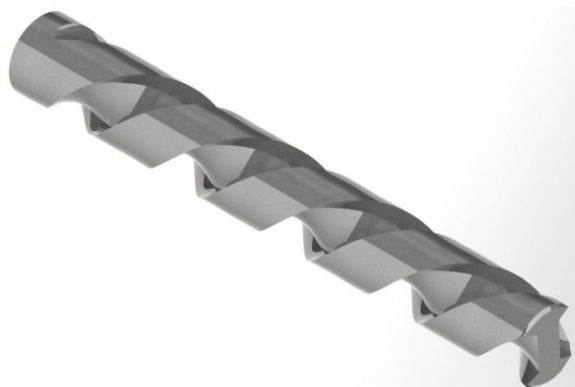


**Figure 10.** Initial 3D model of the guide spindle of the three-spindle screw pump with the feature *Extruded Boss/Base*

With help of the feature for advanced 3D modelling and the feature for final rendering (*Final Render*) a rendered (photorealistic) 3D model of guide spindle (Figure 11.) and guided spindle (Figure 12.) are created.



**Figure 11.** Rendered (photorealistic) display of the 3D model of the guide spindle of the three-spindle screw pump

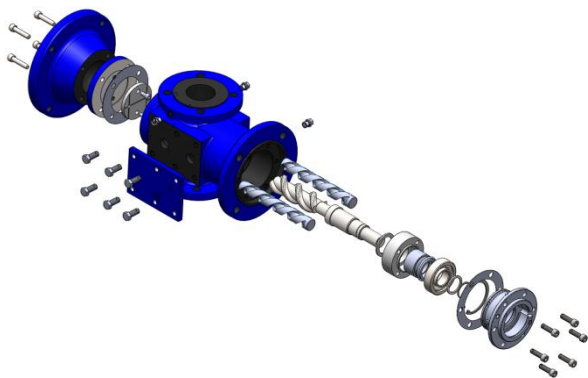


**Figure 12.** Rendered (photorealistic) display of the 3D model of the guided spindle (left helix) of the three-spindle screw pump

In a similar way, the other parts that the assembly of the three-spindle screw pump contains are designed (ring, bearing, housing lid, separator, distance ring, carrier, seal). After modelling of all the needed parts, the assembling is performed (Figure 13. and 14.).



**Figure 13.** Photorealistic display of the 3D model of the assembly of the three-spindle screw pump



**Figure 14.** Exploded View of the 3D model of the assembly of the three-spindle screw pump

### 5. 3D PRINTING OF THE ASSEMBLY MODEL OF THE RETURN FLAP VALVE WITH LEVER AND WEIGHT

3D printing of the model of the three-spindle screw pump (Figure 15.) is achieved with the FDM technology of sedimentary hardening of materials with the 3D printer *MakerBot Replicator 2X*.

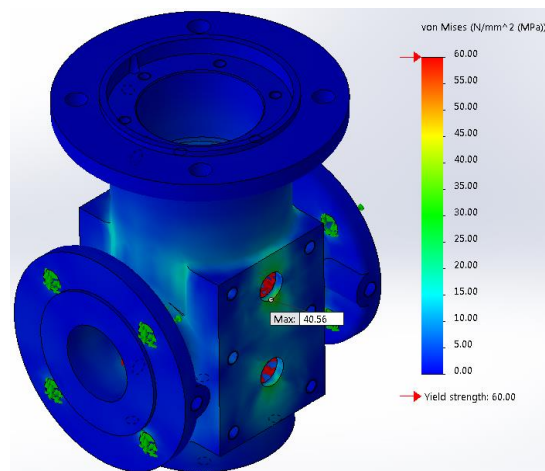


**Figure 15.** Finished (miniature) 3D model of the assembly of the three-spindle screw pump created by the 3D printer *MakerBot Replicator 2X*

### 6. STRESS ANALYSIS (FINITE ELEMENT ANALYSIS – FEA) OF THE HOUSING OF THE THREE-SPINDLE SCREW PUMP

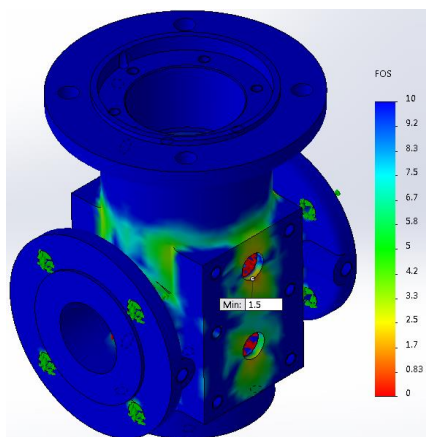
The stress analysis (*Finite Element Analysis - FEA*) of the housing of the three-spindle screw pump is performed in the program module *SolidWorks Simulation* based on the control calculation of the wall thickness of the housing for the test pressure 1,5 MPa (15 bars) and materials SL–25, NL–42 and AlSiMg.

On Figures 16. and 17. are results of the stress analysis (*Finite Element Analysis - FEA*) and safety factor calculation (*Factor Of Safety - FOS*) displayed for the housing of the three-spindle screw pump for the test pressure 1,5 MPa (15 bars), wall thickness of the housing  $\delta = 7 \text{ mm}$  and material SL – 25.



**Figure 16.** Results of the stress analysis of the housing of the three-spindle screw pump with the test pressure 1,5 MPa (15 bars), wall thickness  $\delta = 7 \text{ mm}$  and material SL – 25

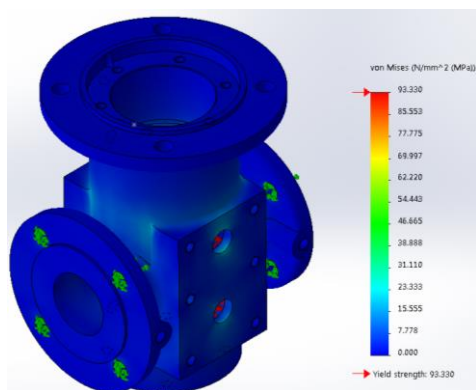
Results of the performed analysis for the material SL – 25 confirm that the nominal stress of the housing of the three-spindle screw pump (Figure 16.) is considerably lower than the allowed stress for the material SL–25 that is mentioned in chapter 3., which amounts to  $\sigma_{dop} = 60\text{N/mm}^2$ , so that it is established that the initial control calculation of the wall thickness of the housing of the three-spindle screw pump is accurate, which is visually and numerically displayed on Figure 16.



**Figure 17.** Factor of safety of the three-spindle screw pump with the test pressure 1,5 MPa (15 bars), wall thickness  $\delta = 7\text{ mm}$  and material SL – 25

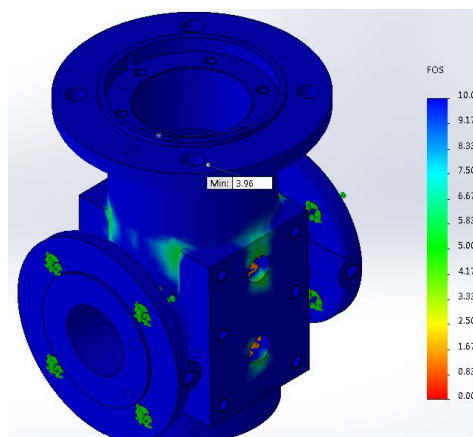
Additionally, the analysis of the safety factor of the three-spindle screw pump (*Factor of Safety – FOS*) for the given test pressure 1,5 MPa is performed. The gained results show that the minimal safety factor (*Factor Of Safety – FOS*) amounts to 1,5; and for the other parts is significantly larger which is visually and numerically displayed on Figure 17., so that it can be concluded that the housing can endure even higher working pressure than the test pressure.

Figures 18. and 19. display the results of the stress analysis (*Finite Element Analysis - FEA*) and safety factor analysis (*Factor Of Safety - FOS*) of the housing of the three-spindle screw pump for the test pressure 1,5 MPa (15 bars), wall thickness  $\delta = 6,5\text{ mm}$  and material NL – 42.



**Figure 18.** Results of the stress analysis of the housing of the three-spindle screw pump with the test pressure 1,5 MPa (15 bars), wall thickness  $\delta = 6,5\text{ mm}$  and material NL – 42

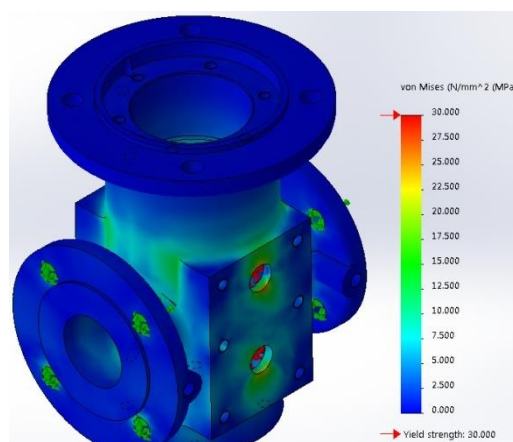
Results of the performed analysis for the material NL – 42 also confirm that the nominal stress of the housing of the three-spindle screw pump (Figure 18.) is considerably lower than the allowed stress for the material NL – 42 that is mentioned in chapter 3., which amounts to  $\sigma_{dop} = 93\text{N/mm}^2$ , so that it is established that the initial control calculation of the wall thickness of the housing of the three-spindle screw pump is accurate, which is visually and numerically displayed on Figure 18.



**Figure 19.** Factor of safety of the three-spindle screw pump with the test pressure 1,5 MPa (15 bars), wall thickness  $\delta = 6,5\text{ mm}$  and material NL – 42

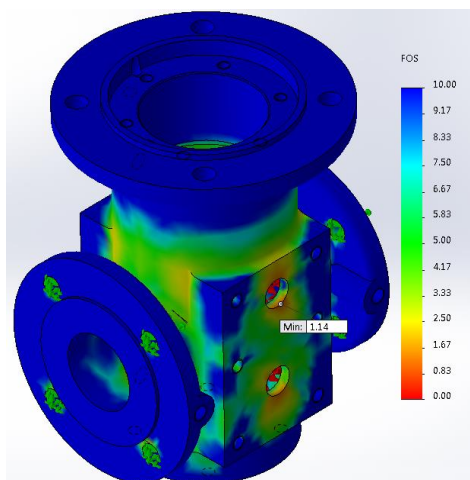
The gained results show that the minimal safety factor (*Factor Of Safety – FOS*) of the heaviest loaded parts of the housing amounts to 3,96 ; and for the other parts is significantly larger which is visually and numerically displayed on Figure 19., so that it can be concluded that the housing can endure an even higher working pressure than the test pressure.

On Figures 20. and 21. are results of the stress analysis (*Finite Element Analysis - FEA*) and safety factor calculation (*Factor Of Safety - FOS*) displayed for the housing of the three-spindle screw pump for the test pressure 1,5 MPa (15 bars), wall thickness of the housing  $\delta = 8,5\text{ mm}$  and material AlSiMg.



**Figure 20.** Results of the stress analysis of the housing of the three-spindle screw pump with the test pressure 1,5 MPa (15 bars), wall thickness  $\delta = 8,5\text{ mm}$  and material AlSiMg

Results of the performed analysis for the material AlSiMg confirm that the nominal stress of the housing of the three-spindle screw pump (Figure 20.) is considerably lower than the allowed stress for the material AlSiMg that is mentioned in chapter 3., which amounts to  $\sigma_{dop} = 30 \text{ N/mm}^2$ , so that it is established that the initial control calculation of the wall thickness of the housing of the three-spindle screw pump is accurate, which is visually and numerically displayed on Figure 20.

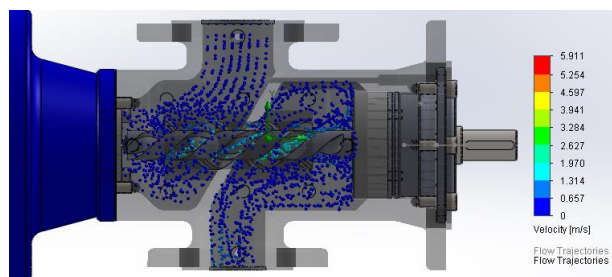


**Figure 21.** Factor of safety of the three-spindle screw pump with the test pressure 1,5 MPa (15 bars), wall thickness  $\delta = 8,5 \text{ mm}$  and material Al.Si.Mg NL – 42

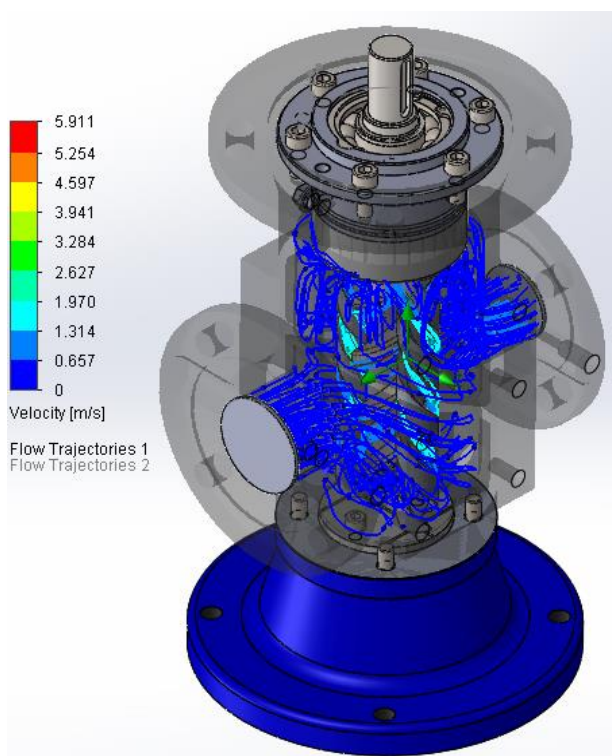
The gained results show that the minimal safety factor (*Factor Of Safety – FOS*) of the heaviest loaded parts of the housing amounts to 1,14 ; and for the other parts is significantly larger which is visually and numerically displayed on Figure 21., so that it can be concluded that the housing can endure even higher working pressure than the test pressure.

## 8. FLUID FLOW ANALYSIS (FLOW SIMULATION)

The analysis of the fluid flow in the 3D model of the assembly of the three-spindle screw pump is performed in the program module *SolidWorks Flow Simulation*. Whereat, the flanges of the housing of the three-spindle screw pump are closed with *Lids* that are used to define the input and output parameters with the *Boundary Conditions* feature. On the input flange, a volume flow rate of  $0,000935 \text{ m}^3/\text{s}$  is given, and on the output flange the atmospheric pressure of 0,1 MPa is set. After defining of all needed parameters, the analysis of the fluid flow is performed. On Figures 22. and 23. the fluid flow is shown with graphical depictions of the fluid flow rate through the 3D model of the pump assembly.



**Figure 22.** Two-dimensional display of the fluid flow and speed rate through the 3D model of the assembly of the three-spindle screw pump



**Figure 23.** Three-dimensional display of the fluid flow and speed rate through the 3D model of the assembly of the three-spindle screw pump

## 9. CONCLUSION

Based on the existing 2D workshop documentation of the cast version, the control calculation of the wall thickness of the housing of the three-spindle screw pump is shown for the test pressure 1,5 MPa (15 bars) and materials SL–25, NL–42 and AlSiMg.

Using reverse engineering, a „flexible“ 3D model of the assembly of the three-spindle screw pump with all parts, just as the complete 2D workshop documentation of the assembly and parts is created. In the program module *SolidWorks Simulation* are performed: stress analysis (*Finite Element Analysis – FEA*) and safety factor analysis (*Factor Of Safety – FOS*) for the housing of the three-spindle screw pump for the test pressure 1,5 MPa (15 bars) and materials SL–25, NL–42 and AlSiMg that confirmed the accuracy of the performed control calculation, as well

as the analysis of the fluid flow in the 3D model of the assembly of the housing of the three-spindle screw pump. With advanced program tools and the program module *SolidWorks Simulation* it was concluded that the 3D model of the housing of the three-spindle screw pump can reliably endure the test pressure, and therefore assure the safe „transport“ of the medium in the pipe systems.

Applying the FDM technology of sedimentary hardening of materials with the 3D printer *MakerBot Replicator 2X* the printing of the miniature 3D model of the assembly of the three-spindle screw pump was performed. This is the preposition for the practical implementation of the improvement and development of machine elements of screw pumps.

## 10. REFERENCES

- [1] Tehnička enciklopedija, Pov-Sap, Leksikografski zavod "Miroslav Krleža", Zagreb, 1987.
- [2] <http://vijcane-pumpe.hr/vijcano-ekscentricne-pumpe> (Dostupno: 03.06.2015.)
- [3] Golubić, S.; Filetin, T.: Izbor materijala za dijelove vijčastih pumpi, Fakultet strojarstva i brodogradnje, Zagreb
- [4] <http://www.mpd-pumpe.hr/media/KATALOZI/VijanepumpetipaPAK-ScrewpumpstypaPAK.pdf> (Dostupno: 04.08.2015.)
- [5] [https://upload.wikimedia.org/wikipedia/commons/1/1a/Screw\\_pump\\_make\\_Kral\\_Cut-away\\_version\\_\(2\).JPG](https://upload.wikimedia.org/wikipedia/commons/1/1a/Screw_pump_make_Kral_Cut-away_version_(2).JPG) (Dostupno: 05.07.2015.)
- [6] <http://www.mpd-umpe.hr/media/DP/Vijanapumpaupresjeku.jpg> (Dostupno: 05.05.2015.)
- [7] <http://turbolab.tamu.edu/proc/pumpproc/P2/P241-46.pdf> (Dostupno: 08.07.2015.)
- [8] Praktičar 3 – Strojarstvo 2, Školska knjiga Zagreb, 1973.
- [9] Kraut, B.: Strojarški priručnik, Zagreb, Tehnička knjiga Zagreb, 1987.

### Authors' contact:

Technical College in Bjelovar  
Trg Eugena Kvaternika 4, HR-43000 Bjelovar

### **Božidar Hršak, mag.ing.mech.**

E-mail: [bhrsak@vtsbj.hr](mailto:bhrsak@vtsbj.hr)

### **Ante Čikić, PhD, Associate Professor**

E-mail: [acikic@vtsbj.hr](mailto:acikic@vtsbj.hr)

### **Tajana Vaško, mag.ing.mech.**

E-mail: [tvasko@vtsbj.hr](mailto:tvasko@vtsbj.hr)

### **Igor Čusek, bacc.ing.mech.**

E-mail: [igor.cusek@gmail.com](mailto:igor.cusek@gmail.com)