

PRIKAZ RADA MOTORA ZRAKOPLOVA

REVIEW OF HOW AERO ENGINES WORK

Amar Singh, Shubham Bharadwaj, Sunny Narayan

Stručni članak

Sažetak: Motori koji se koriste u zrakoplovima pogonskog su tipa koji rade na osnovi potisne sile koja djeluje na njih. U ovom članku prikazan je rad različitih motora. Raspravljani su razni problemi koji se povezuju s tim motorima s budućim mjerama za uklanjanje tih grešaka.

Ključne riječi: zrakoplovni motori, izrada

Professional paper

Abstract: Engines used in aircrafts are propulsion type which work on the basis of thrust force acting on them. In this paper working of various engines has been reviewed. Various problems associated with these engines have been discussed with future remedies to rectify these faults.

Key words: Aero engines, Manufacturing

1. INTRODUCTION

The main function of any aeroplane propulsion system is to provide a force to overcome the aircraft drag, this force is called thrust. Both propeller driven aircraft and jet engines derive their thrust from accelerating a stream of air - the main difference between the two is the amount of air accelerated [1]. A propeller accelerates a large volume of air by a small amount, whereas a jet engine accelerates a small volume of air by a large amount. This can be understood by Newton's 2nd law of motion which is summarized by the equation

$$F = m \times a \text{ (force = mass x acceleration)} \quad (1)$$

Basically the force or thrust (F) is created by accelerating the mass of air (m) by the acceleration (a). Given that thrust is proportional to airflow rate and that engines must be designed to give large thrust per unit engine size, it follows that the jet engine designer will generally attempt to maximize the airflow per unit size of the engine [2]. This means maximizing the speed at which the air can enter the engine, and the fraction of the inlet area that can be devoted to airflow. Gas turbine engines are generally far superior to piston engines in these respects; therefore piston-type jet engines have not been developed.

The gas turbine engine is essentially a heat engine using air as a working fluid to provide thrust. To achieve this, the air passing through the engine has to be accelerated; this means that the velocity or kinetic energy of the air must be increased [3]. First, the pressure energy is raised, followed by the addition of heat energy, before final conversion back to kinetic energy in the form of a high velocity jet.

2. PARTS OF ENGINE

The basic mechanical arrangement of a gas turbine is relatively simple. It consists of only four parts[4]:

- 1) The compressor which is used to increase the pressure (and temperature) of the inlet air.
- 2) One or a number of combustion chambers in which fuel is injected into the high-pressure air as a fine spray, and burned, thereby heating the air. The pressure remains (nearly) constant during combustion, but as the temperature rises, each kilogram of hot air needs to occupy a larger volume than it did when cold and therefore expands through the turbine.
- 3) The turbine which converts some of this temperature rise to rotational energy. This energy is used to drive the compressor.
- 4) The exhaust nozzle which accelerates the air using the remainder of the energy added in the combustor, producing a high velocity jet exhaust.

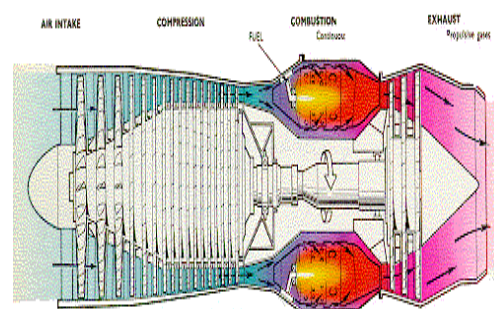

Figure 1. Turbojet engine

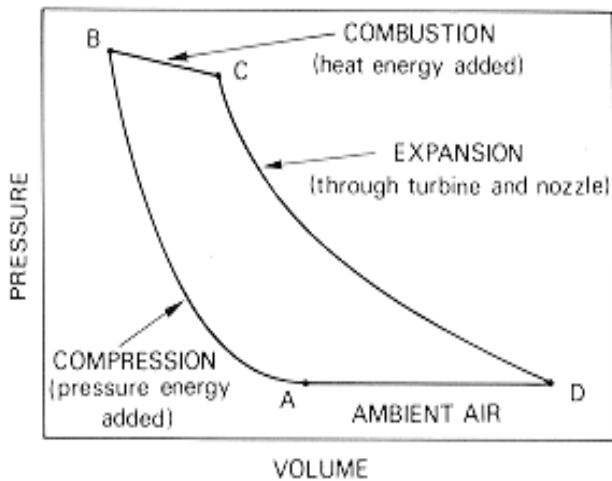

Figure 2. Operation cycle of a turbojet engine

This generalization, however, does not extend to the detailed design of the engine components, where account has to be taken of the high operating temperatures of the combustion chambers and turbine; the effects of varying flows across the compressor and turbine blades; and the design of the exhaust system through which the gases are ejected to form the propulsive jet[6].

3. COMPRESSORS

In the gas turbine engine, compression of the air is effected by one of two basic types of compressor, one giving centrifugal flow and the other axial flow. Both types are driven by the engine turbine and are usually coupled direct to the turbine shaft[7]. The centrifugal flow compressor employs an impeller to accelerate the air and a diffuser to produce the required pressure rise. Flow exits a centrifugal compressor radially (at 90° to the flight direction) and it must therefore be redirected back towards the combustion chamber, resulting in a drop in efficiency[8]. The axial flow compressor employs alternate rows of rotating (rotor) blades, to accelerate the air, and stationary (stator) vanes, to diffuse the air, until the required pressure rise is obtained. The pressure rise that may be obtained in a single stage of an axial compressor is far less than the pressure rise achievable in a single centrifugal stage. This means that for the same pressure rise, an axial compressor needs many stages, but a centrifugal compressor may need only one or two. An engine design using a centrifugal compressor will generally have a larger frontal area than one using a axial compressor[9].

This is partly a consequence of the design of a centrifugal impeller, and partly a result of the need for the diffuser to redirect the flow back towards the combustion chamber[10].



Figure 3. Centrifugal compressor and impeller

As the axial compressor needs more stages than a centrifugal compressor for the equivalent pressure rise, an engine designed with an axial compressor will be longer and thinner than one designed using a centrifugal compressor[11]. This, plus the ability to increase the overall pressure ratio in an axial compressor by the addition of extra stages, has led to the use of axial compressors in most engine designs, however, the centrifugal compressor is still favored for smaller engines where its simplicity, ruggedness and ease of manufacture outweigh any other disadvantages[12].

4. COMBUSTION CHAMBER

The combustion chamber has the difficult task of burning large quantities of fuel, supplied through fuel spray nozzles, with extensive volumes of air, supplied by the compressor, and releasing the resulting heat in such a manner that the air is expanded and accelerated to give a smooth stream of uniformly heated gas. This task must be accomplished with the minimum loss in pressure and with the maximum heat release within the limited space available[13]. The amount of fuel added to the air will depend upon the temperature rise required.

However, the maximum temperature is limited to within the range of 850°C to 1700°C by the materials from

which the turbine blades and nozzles are made. The air has already been heated to between 200°C and 550°C by the work done in the compressor, giving a temperature rise requirement of 650°C to 150°C from the combustion process. Since the gas temperature determines the engine thrust, the combustion chamber must be capable of maintaining stable and efficient combustion over a wide range of engine operating conditions. The temperature of the gas after combustion is about 1800°C to 2000°C, which is far too hot for entry to the nozzle guide vanes of the turbine[14]. The air not used for combustion, which amounts to about 60 percent of the total airflow, is therefore introduced progressively into the flame tube. Approximately one third of this gas is used to lower the temperature inside the combustor; the remainder is used for cooling the walls of the flame tube. There are three main types of combustion chamber in use for gas turbine engines. These are the multiple chambers, the can-annular chamber and the annular chamber[15].

4.1. Types of combustion chambers [16]

(A) MULTIPLE CHAMBER: This type of combustion chamber is used on centrifugal compressor engines and the earlier types of axial flow compressor engines. It is a direct development of the early type of Whittle engine combustion chamber. Chambers are disposed radially around the engine and compressor delivery air is directed by ducts into the individual chambers. Each chamber has an inner flame tube around which there is an air casing. The separate flame tubes are all interconnected. This allows each tube to operate at the same pressure and also allows combustion to propagate around the flame tubes during engine starting.

(B) CAN ANNULAR CHAMBER

This type of combustion chamber bridges the evolutionary gap between multiple and annular types. A number of flame tubes are fitted inside a common air casing. The airflow is similar to that already described. This arrangement combines the ease of overhaul and testing of the multiple system with the compactness of the annular system.

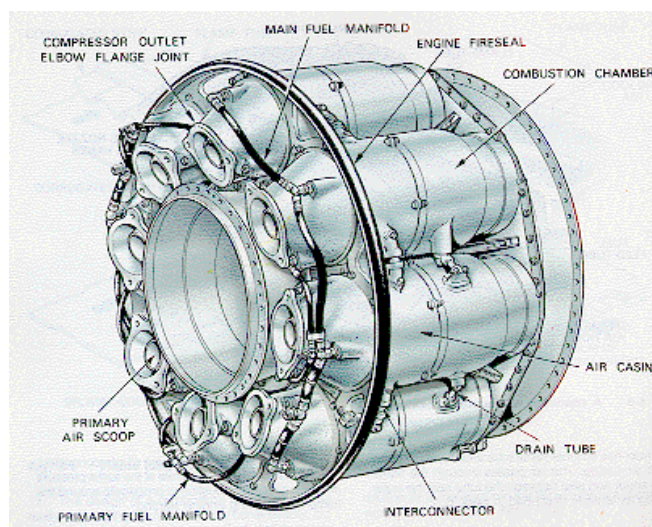

Figure 4. Combustion chamber

(C) ANNULAR CHAMBER

This type of combustion chamber consists of a single flame tube, completely annular in form, which is contained in an inner and outer casing. The main advantage of the annular combustion chamber is that for the same power output, the length of the chamber is only 75 per cent of that of a can-annular system of the same diameter, resulting in a considerable saving in weight and cost. Another advantage is the elimination of combustion propagation problems from chamber to chamber

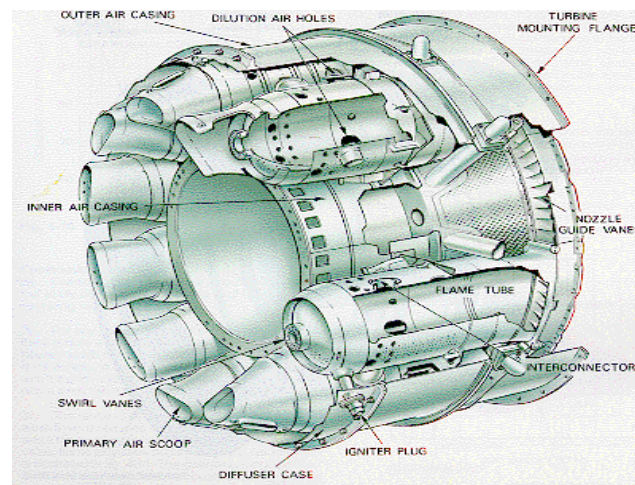

Figure 5. Can annular chamber

5. TURBINE

The turbine has the task of providing power to drive the compressor and accessories. It does this by extracting energy from the hot gases released from the combustion system and expanding them to a lower pressure and temperature. The continuous flow of gas to which the turbine is exposed may enter the turbine at a temperature between 850°C and 1700°C which is far above the melting point of current materials technology. To produce the driving torque, the turbine may consist of several stages, each employing one row of stationary guide vanes, and one row of moving blades. The number of stages depends on the relationship between the power required from the gas flow, the rotational speed at which it must be produced, and the diameter of turbine permitted[17].

The design of the nozzle guide vanes and turbine blade passages is broadly based on aerodynamic considerations, and to obtain optimum efficiency, compatible with compressor and combustor design, the nozzle guide vanes and turbine blades are of a basic aerofoil shape. The desire to produce a high engine efficiency demands a high turbine inlet temperature, but this causes problems as the turbine blades would be required to perform and survive long operating periods at temperatures above their melting point. These blades, while glowing red-hot, must be strong enough to carry the centrifugal loads due to rotation at high speed. To operate under these conditions, cool air is forced out of many small holes in the blade[18]. This air remains close to the blade, preventing it from melting, but not detracting significantly from the engine's overall performance. Nickel alloys are used to construct the turbine blades and the nozzle guide vanes because these

materials demonstrate good properties at high temperatures.

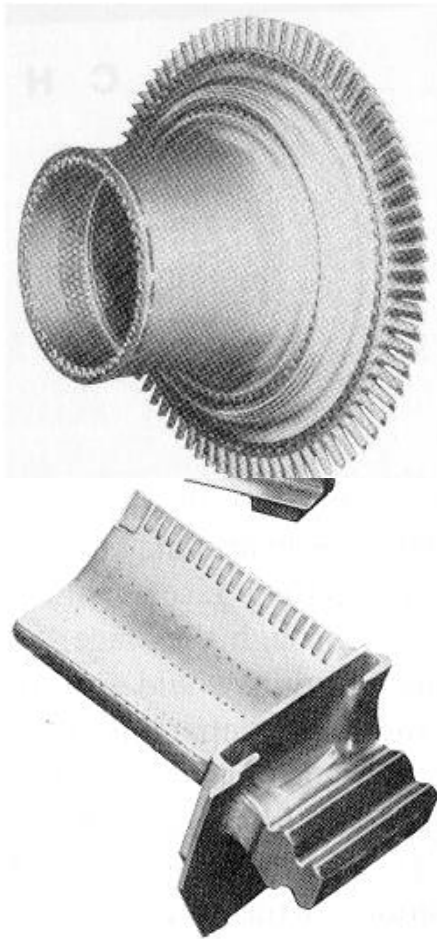

Figure 6. HP-Turbine and a turbine blade

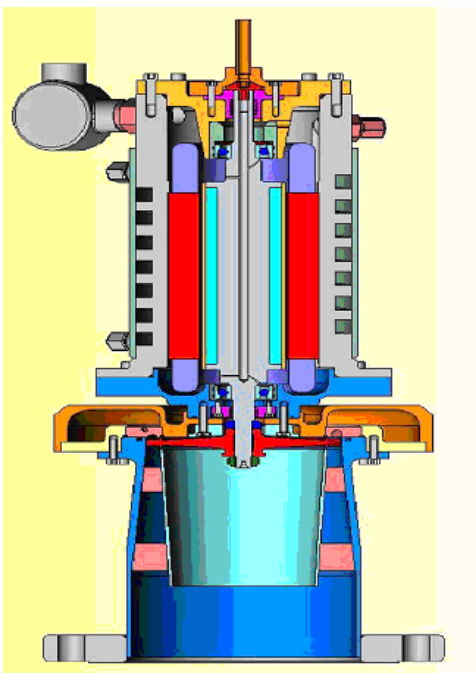

Figure 7. Cross-section of turbo starter of R—29B

6. EXHAUST NOZZLE

Gas turbine engines for aircraft have an exhaust system which passes the turbine discharge gases to atmosphere at a velocity in the required direction, to provide the necessary thrust. The design of the exhaust system, therefore, exerts a considerable influence on the performance of the engine. The cross sectional areas of the jet pipe and propelling or outlet nozzle affect turbine entry temperature, the mass flow rate, and the velocity and pressure of the exhaust jet. A basic exhaust system function is to form the correct outlet area and to prevent heat conduction to the rest of the aircraft. The use of a thrust reverser (to help slow the aircraft on landing), a noise suppresser (to quiet the noisy exhaust jet) or a variable area outlet (to improve the efficiency of the engine over a wider range of operating conditions) produces a more complex exhaust system [19].

7. AFTERBURNER

In addition to the basic components of a gas turbine engine, one other process is occasionally employed to increase the thrust of a given engine. Afterburning (or reheat) is a method of augmenting the basic thrust of an engine to improve the aircraft takeoff, climb and (for military aircraft) combat performance. Afterburning consists of the introduction and burning of raw fuel between the engine turbine and the jet pipe propelling engine nozzle, utilizing the unburned oxygen in the exhaust gas to support combustion [20]. The resultant increase in the temperature of the exhaust gas increases the velocity of the jet leaving the propelling nozzle and therefore increases the engine thrust. This increased thrust could be obtained by the use of a larger engine, but this would increase the weight, frontal area and overall fuel consumption. Afterburning provides the best method of thrust augmentation for short periods. Afterburners are very inefficient as they require a disproportionate increase in fuel consumption for the extra thrust they produce. Afterburning is used in cases where fuel efficiency is not critical, such as when aircraft take off from short runways, and in combat, where a rapid increase in speed may occasionally be required. The big advantage of an afterburner is that we can significantly increase the thrust of the engine without adding much weight or complexity to the engine

An afterburner is nothing but a set of fuel injectors, a tube and flame holder that the fuel burns in, and an adjustable nozzle. A jet engine with an afterburner needs an adjustable nozzle so that it can work both with the afterburners on and off.[21]

The disadvantage of an afterburner is that it uses a lot of fuel for the power it generates. Therefore most planes use afterburners sparingly. For example, a military jet would use its afterburners when taking off from the short runway on an aircraft carrier. The following pictures show some of the details of an afterburner-equipped engine. This particular engine comes from an F-4.

This includes the compressor, combustion chamber and exhaust turbine. At the exhaust end of the engine, we can see a ring of injectors for the afterburner.



Figure 8. Fuel injectors

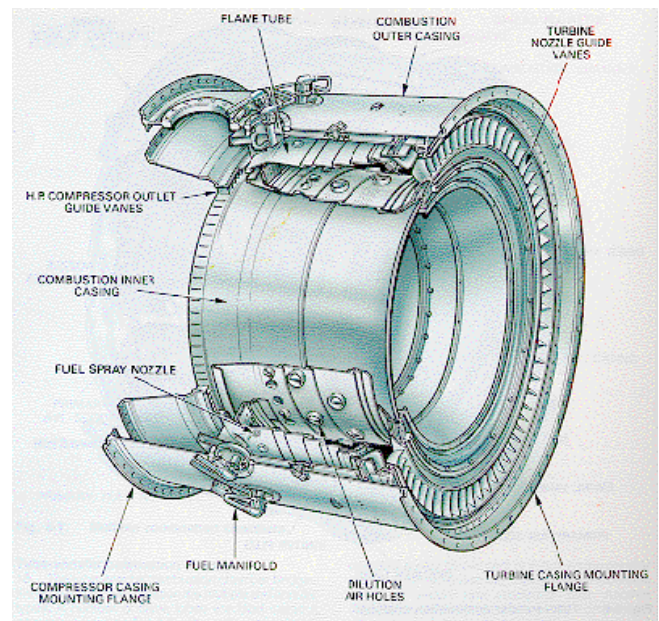

Figure 10. Annular chamber

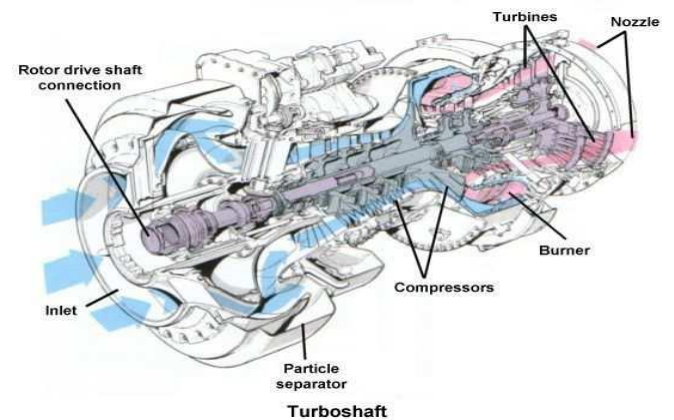

Figure 11. Cross section of a turbo-jet engine

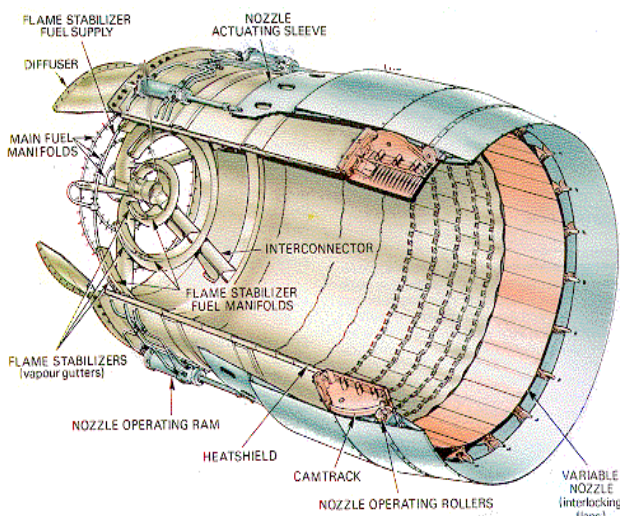

Figure 9. Afterburner

8. COOLING OF TURBO-JET

Various components of jet engines need to be cooled to ensure safe and efficient operation. This is particularly true for the combustor, for the turbine blades and for various accessories. Because of the direct relationship between turbine inlet temperature and engine operating efficiency, much development emphasis has been given to combustor and turbine blade materials and designs which can tolerate such high temperatures. In fact, many of today's turbine engines operate at turbine inlet temperatures which are above the melting point of the materials used in the turbine blades. Hence adequate cooling techniques are a must[22].

Several engine accessories, in particular the engine generator, must also be cooled. In flight, this is done by ducting outside air from special cooling air intakes toward the accessories. During ground operation this does not work and low pressure air is tapped from the compressor and ducted to the accessories. This would hurt the efficiency of the engine in flight and therefore a valving system is used to switch from external air to compressor air and vice-versa.

A schematic of an arrangement for cooling the engine generator is shown in figure given:

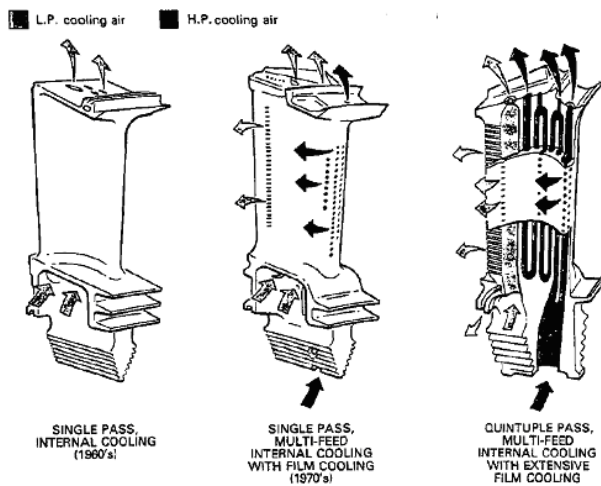

Figure 12. Development of Turbine Blade Cooling

The design of the nacelle which cowl the engine must be taken into consideration. It should be expected that if large power outputs are required for the accessory drive system, they will tend to require a significant amount of volume. This in turn will affect the size and shape of the nacelle which in turn affects the weight and drag of the airplane. Also structural provisions must be made to mount the engine to the airframe. These structural provisions must take into account the weight and the thrust output of the engine. This also requires additional volume in the nacelle[23].

9. CONCLUSIONS

In-flight icing is a serious hazard. It destroys the smooth flow of air, increasing drag, degrading control authority and decreasing the ability of an airfoil to lift. The actual weight of the ice on the aeroplane is secondary to the airflow disruption it causes. As power is added to compensate for the additional drag and the nose is lifted to maintain altitude, the angle of attack increases, allowing the underside of the wings and fuselage to accumulate additional ice. Ice accumulates on every exposed frontal surface of the aeroplane – not just on the wings, propeller, and windshield, but also on the antennas, vents, intakes, and cowlings. It builds in flight where no heat or boots can reach it. It can cause antennas to vibrate so severely that they break. In moderate to severe conditions, a light aircraft can become so iced up that continued flight is impossible. The aeroplane may stall at much higher speeds and lower angles of attack than normal. It can roll or pitch uncontrollably, and recovery may be impossible[24].

Once a tail plane stall is encountered, the stall condition tends to worsen with increased airspeed and possibly may worsen with increased power settings at the same flap setting. Airspeed, at any flap setting, in excess of the aero plane manufacturer's recommendations for the flight and environmental conditions, accompanied by uncleaned ice contaminating the tail plane, may result in a

tail plane stall and uncommanded pitch down from which recovery may not be possible.

Tail plane stall symptoms include:

- Elevator control pulsing, oscillations, or vibrations.
- Abnormal nose down trim change.
- Any other unusual or abnormal pitch anomalies (possibly resulting in pilot induced oscillations).
- Reduction or loss of elevator effectiveness.
- Sudden change in elevator force (control would move nose down if unrestrained).
- Sudden uncommanded nose down pitch.

10. REFERENCES

- V.V. Kozlaykov, System analysis of jet engines of high supersonic flight velocities, *Aerospace Science and Technology*, Volume 1, Issue 3, April 1997, Pages 179–182.
- Guy Wells1, , Steve Morgan, Bruno Masse, Hermann Scheugenpflug, *EEFAE - efficient and environmentally friendly aero engine - technology platform*, Air & Space Europe, Volume 3, Issues 3–4, May–August 2001, Pages 163–165.
- www.aardvark.co.nz/pjet/inside_pj.pdf
- www.smartcockpit.com/docs/Jet_Engines_Basics.pdf
- Adrian D. Nembhard, Jyoti K. Sinha, Unified Multi-speed analysis (UMA) for the condition monitoring of aero-engines *Original Research Article Mechanical Systems and Signal Processing*, Volumes 64–65, December 2015, Pages 84–99.
- Chen Guo, Study on the recognition of aero-engine blade-casing rubbing fault based on the casing vibration acceleration, *Measurement*, Volume 65, April 2015, Pages 71–80
- Liu Hongxia, Zhang Shifu, Liang Chunhua, Liu Qi, Development Strategy Study for Commercial Aero Engine Companies in European Countries and the United State, *Procedia Engineering*, Volume 99, 2015, Pages 804–811
- Zhenhua Wen, Xiaojun Ma, Hongfu Zo, Characteristics analysis and experiment verification of electrostatic sensor for aero-engine exhaust gas monitoring, *Measurement*, Volume 47, January 2014, Pages 633–644.
- <http://www.ansys.com/Industries/Industrial+Equipment+&+Rotating+Machinery/Aircraft+Engines>
- <http://www.cranfield.ac.uk/Study/Research-degrees/Current-research-opportunities/phd/Aeroengine-Design-and-Performance-Optimisation-with-Rolls-Royce>.
- Xuan HJ, Wu RR. Aeroengine turbine blade containment tests using high-speed rotor spin testing facility. *Aerospace Science and Technology* 2006;10(6):501–8.
- Sarkar S, Atluri SN. Effects of multiple blade interaction on the containment of blade fragments during a rotor failure. *Finite Elements in Analysis and Design* 1996;23(2–4):211–23.
- Mathis JA, Parduhn SC, Alvarez P. Analysis of turbine rotor containment and shielding structures.

- In: AIAA/SAE/ASME/ ASEE 29th Joint Propulsion Conference and Exhibit, 1993. Report No. AIAA-93-1817.
- [14] Carney K, Pereira M, Revilock D, Matheny P. Jet engine fan blade containment using two alternate geometries. The 4th European LS-DYNA conference, 2003; I-I-01-I-I-10.
- [15] Robert GD, Revilock DM. Impact testing and analysis of composites for aircraft engine fan cases. 2002 April. Report No.: NASA TM-2002-211493.
- [16] Astrid K, Jorg F. Containment and penetration simulation in case of blade loss in a low pressure turbine. In: DYNA more LSDYNA Forum, 2002.
- [17] Pereira JM, Lerch B. Effects of heat treatment on the ballistic impact properties of Inconel 718 for jet engine fan containment applications. *International Journal of Impact Engineering* 2002;25(8):715–33.
- [18] Simons J, Erlich D, Shockey D. Explicit finite element modeling of multilayer composite fabric for gas turbine engine containment systems. Part 3: model development and simulation of experiments. Federal Aviation Administration; 2004. Report No.: AR-04/40/P3.
- [19] Skira CA, Agnello M. Control systems for the next century's fighter engines. *J Eng Gas Turbines Power* 1992;114(4):749–54.
- [20] Jaw LC, Mattingly JD. Aircraft engine controls: design, system analysis and health monitoring. Reston: AIAA; 2009.
- [21] Blakelock JH. Automatic control of aircraft and missiles. New York: Wiley; 1991.
- [22] Garg S. Robust integrated flight/propulsion control design for a STOVL aircraft using H1 control design techniques. *Automatica* 1993;29(1):129–45.
- [23] Liu XF, Zhao L. Approximate nonlinear modeling of aircraft engine surge margin based on equilibrium manifold expansion. *Chin J Aeronaut* 2012;25(5):663–74.
- [24] Frederick DK, Garg S, Adibhatla S. Turbofan engine control design using robust multivariable control technologies. *IEEE Trans Control Syst Technol* 2000;8(6):961–70.

Author contact:

Amar Singh
Shubham Bharadwaj
Sunny Narayan
Mechanical engg department
Indus University ,india
e-mail: rarekv@gmail.com