

Zoran Pandilov
Andrzej Milecki
Amadeusz Nowak
Filip Górski
Damian Grajewski
Damir Ciglar
Tihomir Mulc
Miho Klaić

ISSN 1333-1124
eISSN 1849-1391

VIRTUAL MODELLING AND SIMULATION OF A CNC MACHINE FEED DRIVE SYSTEM

Summary

This paper deals with the virtual modelling and simulation of a complex CNC machine tool feed drive system. The first phase of the study was the modelling of a very complex structure of the feed drive which consists of many elements (position, velocity and current control regulators, actuators, mechanical transmission elements, etc.). All these elements have great influence on important parameters of the machine tool such as movement stability, positioning accuracy and dynamic stiffness. For the modelling of the system the Matlab-SIMULINK and Matlab-Sim Scape Toolbox software was used. The Matlab-Sim Scape Toolbox allowed us to use the complete CAD model of the geometry of the machine tool, automatically calculating the selected properties.

The influence of changing and optimizing several feed drive parameters (position loop gain K_v , proportional gain K_p of the velocity controller, integral gain of velocity controller- T_n , electrical drive time constant T_e , total moving mass m , sampling period T_s , etc.) on the positioning accuracy and the dynamic stiffness was simulated, tested and validated.

The finished Matlab-Simulink and Sim Scape models were initially visualized in the Matlab program. They were very simplified, comparing with their later visualization in the Virtual Reality EON Studio program.

Key words: virtual modelling, simulation, CNC machine tool feed drive

1. Introduction

Since the early 1990s a paradigm shift from 'real' to 'virtual' production has resulted in an increase in research interest in the field. With the aid of computers, it has become possible to simulate some of the activities of a physical manufacturing system. The main objective is to understand and emulate the behaviour of a particular manufacturing system on a computer prior to physical production, thus reducing the amount of testing and experiments on the shop floor. By using a virtual system, less material is wasted and interruptions in the operation of

an actual machine on the shop floor can be avoided [1,2]. In the field of CNC machining, various modelling and simulation techniques have been introduced so far. They are of vital importance for improvement and cost reduction in production [3, 4, 5, 6, 7].

The goal of the modern manufacturing technologies is to produce already the first part correctly in the shortest period of time and in the most cost effective way. Since the product complexities increase and the competitive product life cycle times are reduced, the construction and testing of physical prototypes become major bottlenecks to the successful and economically advantageous production of modern machine tools [8].

Presently, the machine tool builders can no longer afford the time-consuming and cost-intensive manufacturing and testing of physical prototypes to detect weak spots and then optimise the design. Instead, the design processes of modern machine tools employ the “virtual prototyping” technology to reduce the cost and time of hardware testing and iterative improvements to the physical prototype. The virtual prototype of a machine tool is a computer simulation model of a physical product that can be presented, analysed and tested like a real machine. Iterative changing of a virtual model of the machine tool during the design process and exercising design variations until the performance requirements are achieved reduce the whole product development time and cost significantly [9].

The most important parts of every machine tool are feed drives. Feed drives of CNC machine tools are very complex electro-mechanical systems. They must exhibit especially good control dynamics, position accuracy, load stiffness, acceleration capacity and process velocity [10, 11].

This paper deals with virtual modelling, simulation, optimization and visualisation of the CNC machine feed drive system.

2. Modelling and simulation of virtual CNC machine feed drive system with MATLAB/SIMULINK as one mass model

The productivity and accuracy of every CNC machine tool highly depends on feed drive characteristics. The feed drive main purpose is to move the working parts of the machine tool (working table, tool unit, spindle unit etc.) through the machine axes. A separate feed drive is necessary for every machine axis. Although, generally, feed drives have a very simple kinematics structure their optimal design is a problem which consists of selecting actuators, mechanical transmission elements and applying and tuning current, velocity and position controllers. All these elements must satisfy some requirements as a system and they also have great influence on the important parameters of the machine tool such as movement stability, positioning accuracy and dynamic stiffness [12, 13, 14].

Usually, the feed drive consists of an actuator (rotary or linear), mechanical transmission elements and a cascade control of three loops (PI current control loop, PI velocity control loop, P position control loop). The mechanical transmission elements comprise all the machine parts which lie in the torque (power) transmission flow between the actuator and the tool or the workpiece. In different design variants the following mechanical transmission elements are most frequently used: clutches, ball lead screw and nut units, rack and pinion units, bearings, gears, gearboxes.

The first step in the study was the creation of a virtual 3D CAD model of one CNC portal milling machine (Fig. 1) with a direct lead screw feed drive for all three axes (Fig. 2)

The technical data of the feed drive for the virtually modelled Y-axis are: maximal force $F_{max}=3500$ N, maximal speed $V_{max}=15$ m/min, nominal speed $V_{nom}=10$ m/min, acceleration $a=2$ m/s², total moving mass $m=60$ kg, diameter of the lead screw $d_{sp}=16$ mm=0.016 m, pitch of the lead screw $h_{sp}=5$ mm=0.005 m, digital AC motor B&R 8LSA43.ee030ffgg-0.

The simplified one mass models of the position and the velocity loops of the Y-axis feed drive system are presented in Fig. 3 and Fig. 4.

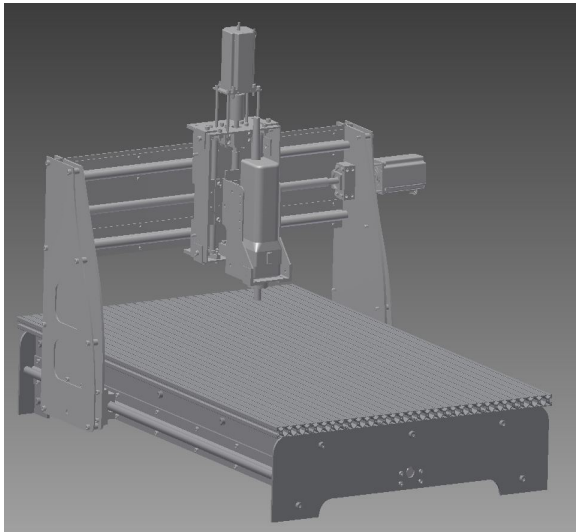

Fig. 1 CAD model of CNC portal machine tool

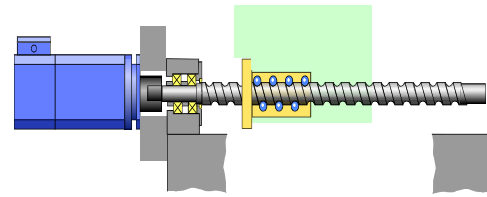

Fig. 2 Direct lead screw feed drive

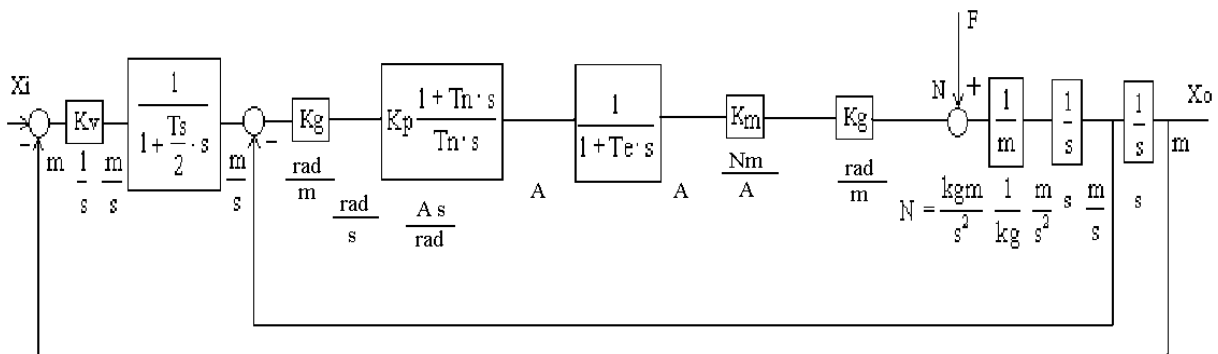

Fig. 3 Simplified one mass model of the position loop of Y-axis feed drive of virtual CNC portal milling machine

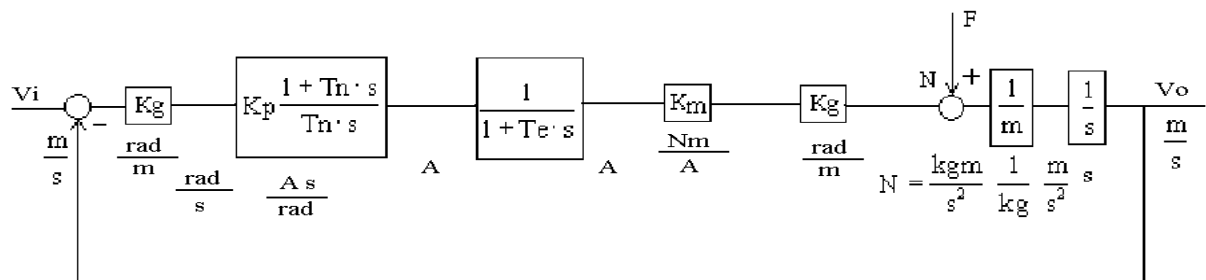

Fig. 4 Simplified one mass model of the velocity loop of Y-axis feed drive of virtual CNC portal milling machine

The parameters of the models given in Fig. 3 and Fig. 4 are: K_v -position loop gain [1/s], T_s -sampling period [s], s -Laplace operator, K_p -proportional gain of the velocity controller [As/rad], T_n -integral time of the velocity controller [s], T_e -time constant of the current loop [s], F -disturbance force [N], m -mass of the moving elements [kg], X_i -input position [m], X_o -output position [m], K_m -torque constant of the rotary motor [Nm/A], K_g -constant for transformation of the linear in the rotary movement [rad/m].

$K_g = \frac{2\pi \cdot i}{h_{sp}}$, where i is the reduction ratio, and h_{sp} is the pitch of the lead screw [m]. In

our case, $i=1$ for the direct screw drive.

A dual loop controller with a PI controller for the speed loop and a P controller for the position loop have been implemented in the CNC machine Y-axis feed drive. In fact, the speed signal is derived from the position measurement by digital derivation.

The transfer function of the position loop of the CNC machine feed drive Y-axis is given by equation (1):

$$\frac{X_o(s)}{X_i(s)} = \frac{b_1 s + b_0}{a_5 s^5 + a_4 s^4 + a_3 s^3 + a_2 s^2 + a_1 s + a_0} \quad (1)$$

Coefficients in equation (1) are:

$$b_1 = T_n, \quad b_0 = 1, \quad a_5 = \frac{T_s \cdot T_n \cdot T_e \cdot m}{2 \cdot K_p \cdot K_v \cdot K_m \cdot K_g^2}, \quad a_4 = \frac{T_n \cdot m}{K_p \cdot K_v \cdot K_m \cdot K_g^2} \cdot \left(T_e + \frac{T_s}{2} \right),$$

$$a_3 = \frac{T_n}{K_v} \cdot \left(\frac{m}{K_p \cdot K_m \cdot K_g^2} + \frac{T_s}{2} \right), \quad a_2 = \frac{1}{K_v} \cdot \left(T_n + \frac{T_s}{2} \right), \quad a_1 = \frac{1}{K_v} + T_n, \quad a_0 = 1$$

The transfer function of the velocity loop of the CNC machine feed drive Y-axis is given by equation (2):

$$\frac{V_o(s)}{V_i(s)} = \frac{b_1 \cdot s + b_0}{a_3 \cdot s^3 + a_2 \cdot s^2 + a_1 \cdot s + a_0} \quad (2)$$

Coefficients in equation (2) are:

$$b_1 = T_n, \quad b_0 = 1, \quad a_3 = \frac{T_n \cdot T_e \cdot m}{K_p \cdot K_m \cdot K_g^2}, \quad a_2 = \frac{T_n \cdot m}{K_p \cdot K_m \cdot K_g^2}, \quad a_1 = T_n, \quad a_0 = 1$$

The transfer function of the compliance for the CNC machine feed drive Y-axis of the virtual portal milling machine is given by equation (3)

$$\frac{X_o(s)}{F(s)} = \frac{b_3 s^3 + b_2 s^2 + b_1 s + b_0}{a_5 s^5 + a_4 s^4 + a_3 s^3 + a_2 s^2 + a_1 s + a_0} \quad (3)$$

Coefficients in equation (3) are:

$$b_3 = T_e \cdot \frac{T_s}{2}, \quad b_2 = T_e + \frac{T_s}{2}, \quad b_1 = 1, \quad b_0 = 0, \quad a_5 = m \cdot T_e \cdot \frac{T_s}{2}, \quad a_4 = m \cdot \left(T_e + \frac{T_s}{2} \right),$$

$$a_3 = m + \frac{K_p \cdot K_m \cdot K_g^2 \cdot T_s}{2}, \quad a_2 = \frac{K_p \cdot K_m \cdot K_g^2}{T_n} \cdot \left(T_n + \frac{T_s}{2} \right), \quad a_1 = \frac{K_p \cdot K_m \cdot K_g^2}{T_n} \cdot (1 + K_v \cdot T_n)$$

and $a_0 = \frac{K_p \cdot K_m \cdot K_g^2}{T_n} \cdot K_v.$

Using the models given in Fig. 3 and Fig. 4, one mass model is created in MATLAB/SIMULINK, given in Fig. 5.

With the aid of the bode diagrams of the position (Fig. 6) and the velocity loop (Fig.7) of the Y-axis feed drive, obtained with the SIMULINK one mass model shown in Fig. 5, the bandwidth of the position and the velocity loop is calculated.

The amplitude in the bode diagrams can be calculated using equation (4)

$$|F(j\omega)| \text{ dB} = 20 \log |F(j\omega)| \quad |F(j\omega)| = 10^{\frac{|F(j\omega)| \text{ dB}}{20}} \quad (4)$$

The cut-off angular frequency ω_g is a point at which the amplitude response has dropped by -3 dB.

A conversion of the above equation results in $|F(j\omega)| = 10^{\frac{-3}{20}} = 0.7079$.

The frequency range from 0 to ω_g is called the bandwidth.

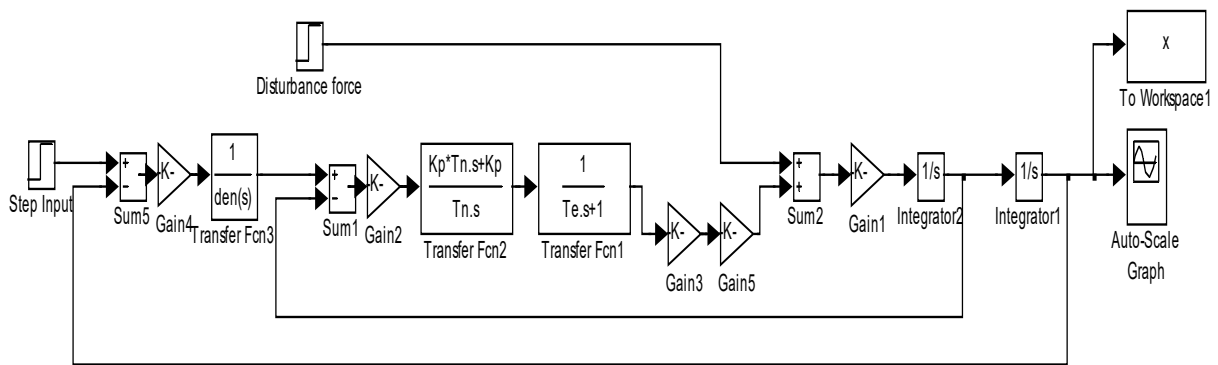

Fig. 5 Simulink one mass model of Y-axis feed drive

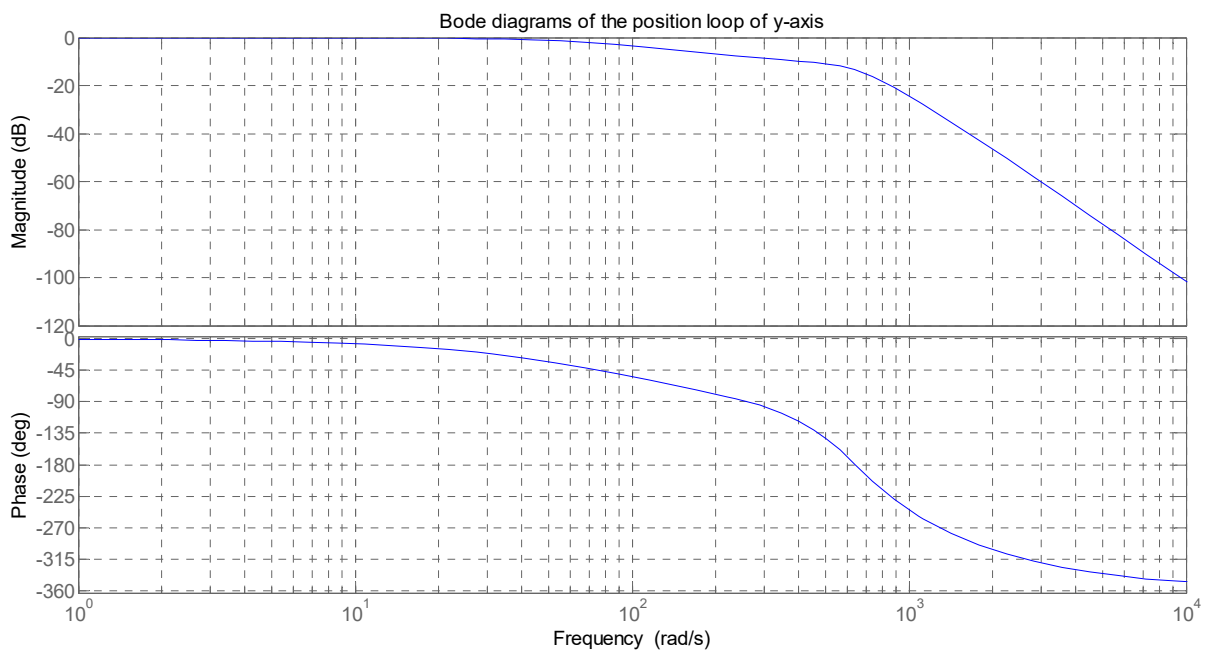

Fig. 6 Bode diagrams of position loop of Y-axis of virtual portal milling machine

The bandwidth of the position loop of the Y-axis of the virtual portal milling machine is approximately 14.5 Hz.

The bandwidth of the velocity loop of the Y-axis of the virtual portal milling machine is approximately 196 Hz.

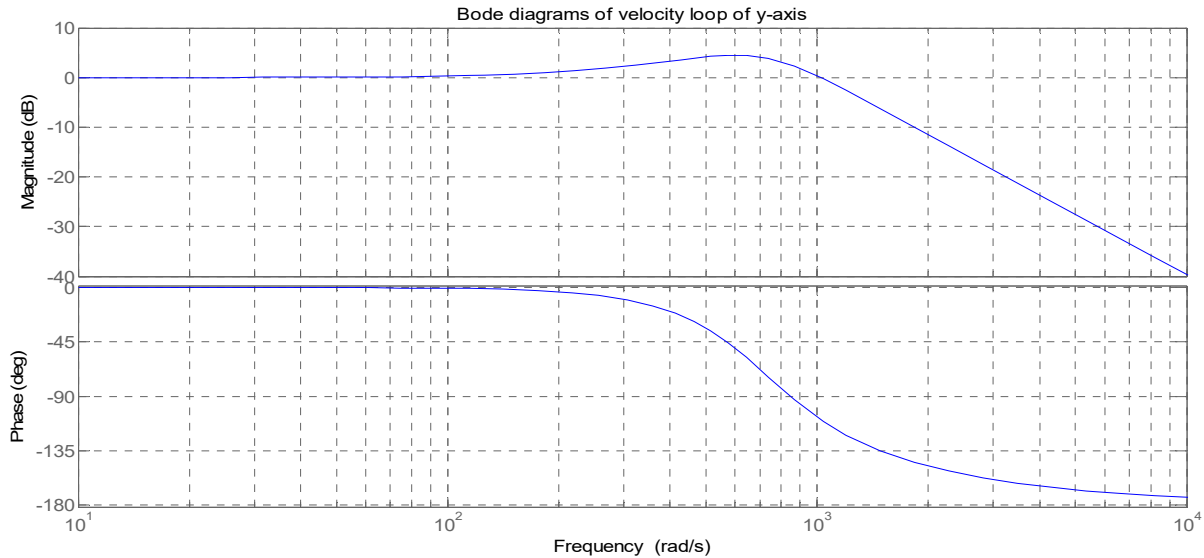

Fig. 7 Bode diagrams of velocity loop of Y-axis of virtual portal milling machine

Using the SIMULINK one mass model of the CNC machine Y-axis feed drive shown in Fig. 5, the influence of changing the parameters K_v , K_p , T_n , m , T_e and T_s on the bandwidth of the position loop and the velocity loop (examples are given in Fig. 8 and Fig. 9) and the compliance of the feed drive of the Y-axis of the virtual portal milling machine in the frequency domain (examples are given in Fig. 10 and Fig. 11) are simulated.

Nominal values of the parameters of the Y-axis feed drive of the virtual milling machine are given as follows: $K_v=80$ - position loop gain [1/s], $T_s=0.002$ - sampling period [s], $K_p=0.017$ - proportional gain of the velocity controller [As/rad], $T_n=0.0028$ -integral time of the velocity controller [s], $T_e=0.0007$ - time constant of the current loop [s], $m=60$ - mass of the moving elements [kg], $K_m= 1.63$ - torque constant of the rotary motor [Nm/A], $K_g= 1256$ - constant for the transformation of linear to rotary movement [rad/m].

In the simulations, one parameter was changed and the others were kept constant. The parameter was changed $\pm 100\%$.

One of the most important requirements with regard to the feed drive system concerns its sensitivity to load disturbances. The qualitative measure of this sensitivity is the feed drive stiffness.

The dynamic feed drive system stiffness can be defined as a measure of influence of the disturbance force F (torque T) on the output position X_o (angular position θ_o) deviation in the transient period [15].

$$S_d(s) = \frac{F(s)}{X_o(s)} = \frac{T(s)}{\theta_o(s)} \quad (5)$$

From the simplified model of the position loop of the Y-axis of the portal milling machine the dynamic stiffness of the feed drive system becomes:

$$S_d(s) = \frac{F(s)}{X_o(s)} = \frac{a_5s^5 + a_4s^4 + a_3s^3 + a_2s^2 + a_1s + a_0}{b_3s^3 + b_2s^2 + b_1s + b_0} \quad (6)$$

Coefficients in the equation are:

$$b_3 = Te \cdot \frac{Ts}{2}, \quad b_2 = Te + \frac{Ts}{2}, \quad b_1 = 1, \quad b_0 = 0, \quad a_5 = m \cdot Te \cdot \frac{Ts}{2}, \quad a_4 = m \cdot \left(Te + \frac{Ts}{2} \right),$$

$$a_3 = m + \frac{Kp \cdot Km \cdot Kg^2 \cdot Ts}{2}, \quad a_2 = \frac{Kp \cdot Km \cdot Kg^2}{Tn} \cdot \left(Tn + \frac{Ts}{2} \right), \quad a_1 = \frac{Kp \cdot Km \cdot Kg^2}{Tn} \cdot (1 + Kv \cdot Tn)$$

and $a_0 = \frac{Kp \cdot Km \cdot Kg^2}{Tn} \cdot Kv.$

Compliance is in fact an inverse value of the dynamic stiffness.

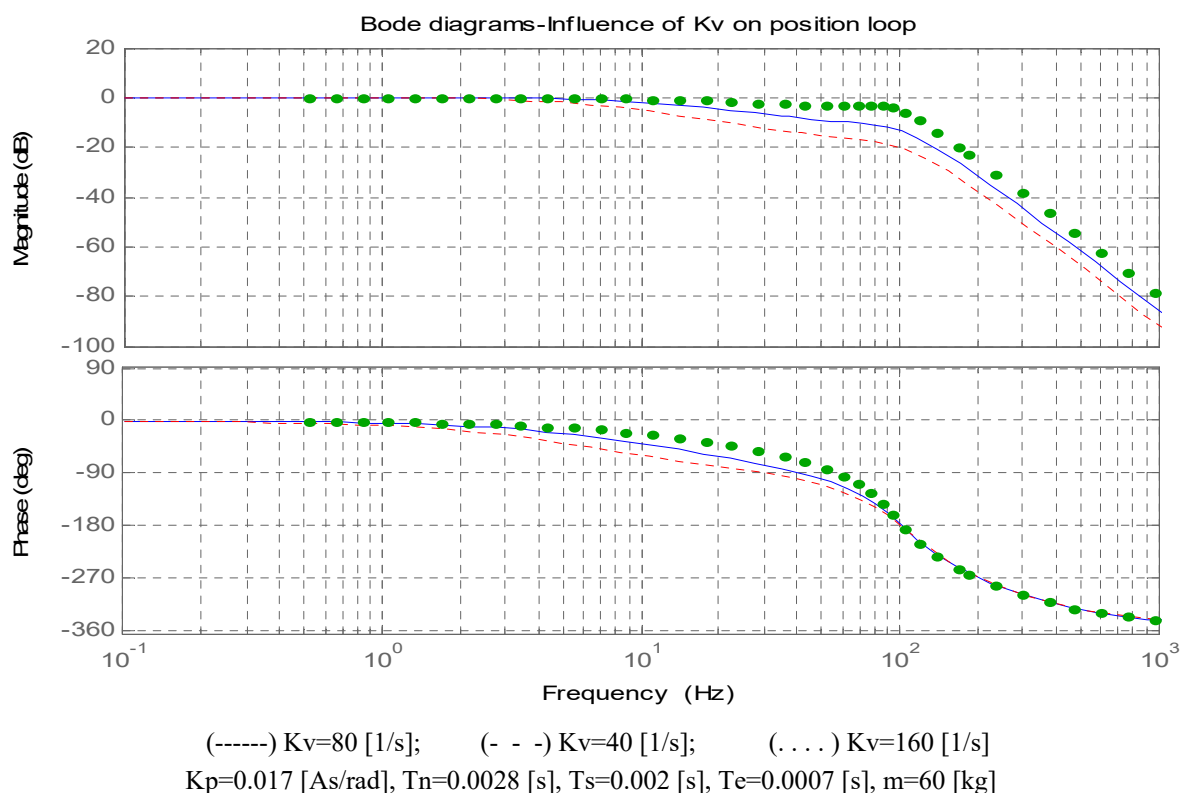

Fig. 8 Influence of different values of position loop gain Kv on bandwidth of position loop of Y-axis feed drive

For example, the influence of Kp and m on the compliance in the frequency domain of the Y-axis feed drive is shown in Fig. 10 and Fig. 11.

A simulation of the dynamic stiffness of the feed drive of the Y-axis of the portal milling machine and the influence of changing Kv, Kp, Tn, m, Te and Ts on the dynamic stiffness in the time domain, using the SIMULINK model given in Fig. 5 has also been carried out.

$$X_o(t) = L^{-1} \left[\frac{X_o(s)}{F(s)} \cdot \frac{F}{s} \right] \text{ [m]} \quad (7)$$

The following equation is used to estimate the dynamic stiffness:

$$Sd = \frac{F}{\max Xo(t)} \text{ [N/m]} \quad (8)$$

$$Sd = \frac{F}{\max Xo(t) \cdot 10^6} \text{ [N/}\mu\text{m]} \quad (9)$$

where F is the disturbance force and maxXo(t) is the maximal position deviation (displacement) caused by the disturbance force.

The disturbance force used in the simulation F is 1000 [N].

The dynamic stiffness is in fact a reciprocal value of compliance.

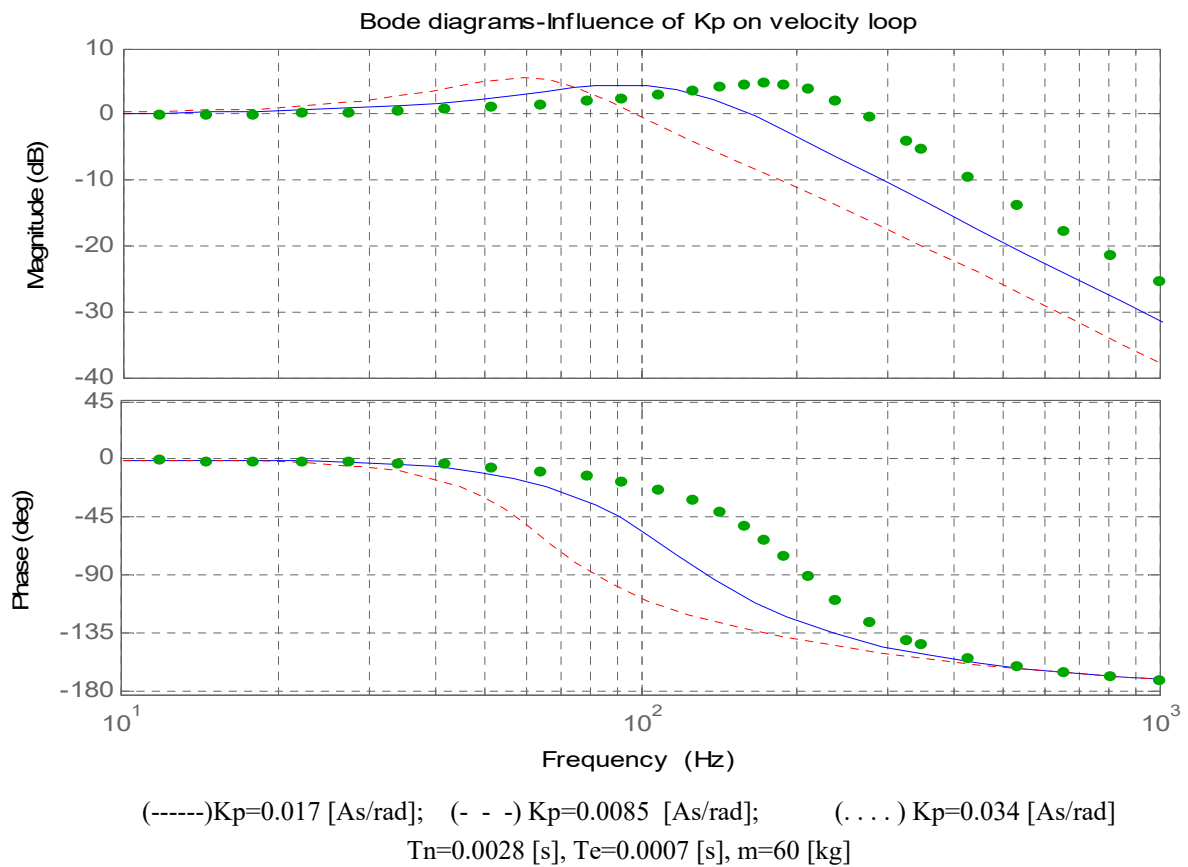

Fig. 9 Influence of different values of proportional gain of velocity controller Kp on bandwidth of velocity loop of Y-axis feed drive

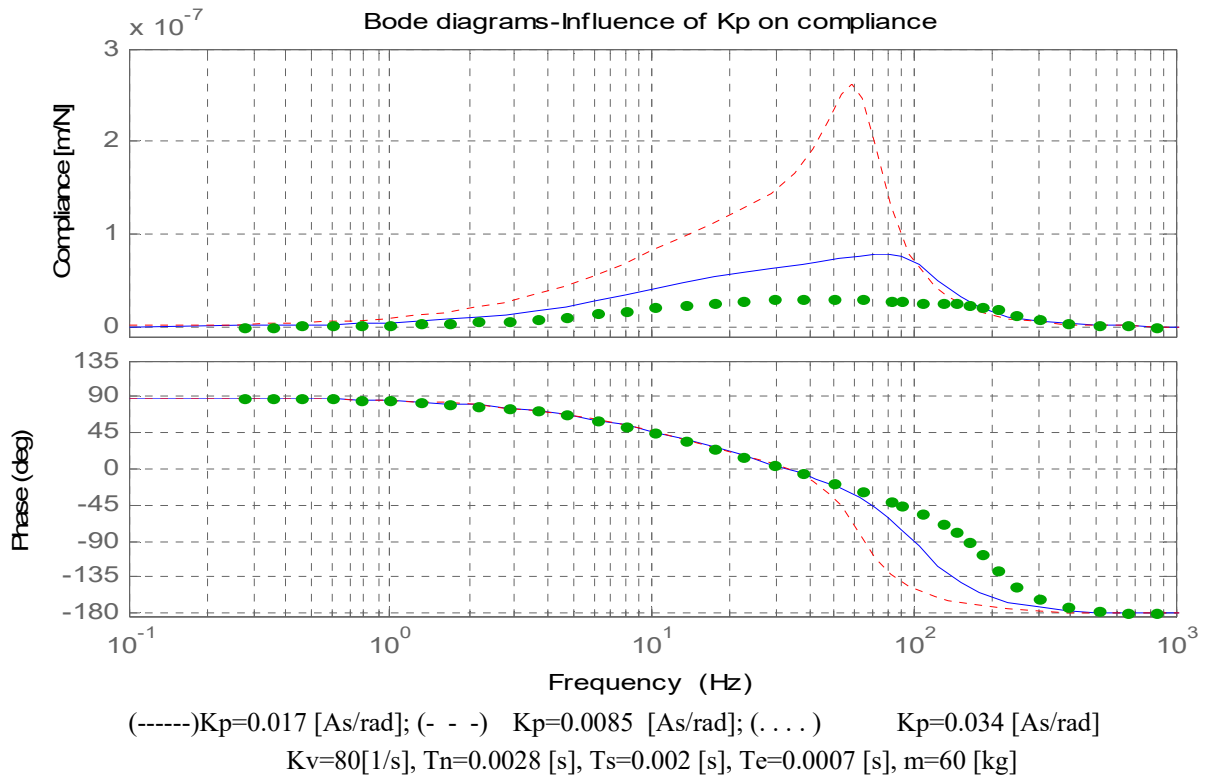

Fig. 10 Influence of different values of proportional gain of velocity controller K_p on compliance of Y-axis feed drive

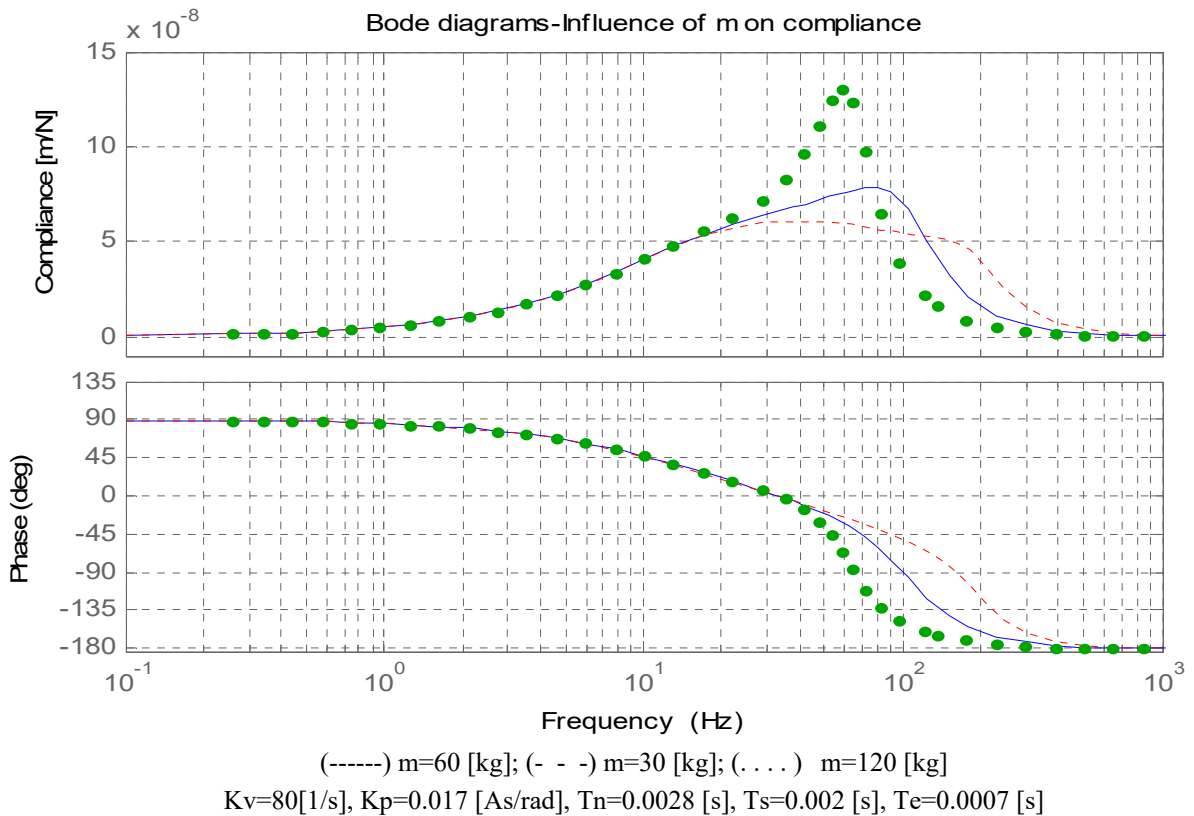

Fig. 11 Influence of different values of mass of moving elements m on compliance of Y-axis feed drive

The influence of different values of K_p and T_n on compliance are shown in Fig. 12 and Fig. 13.

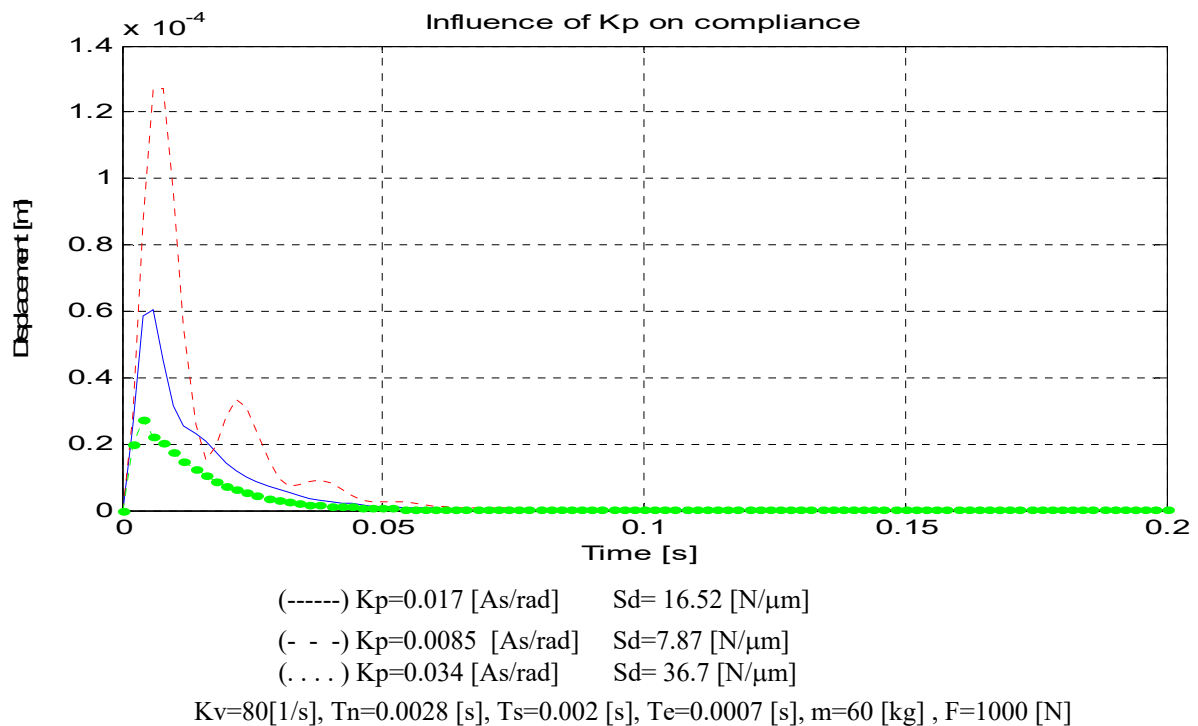

Fig. 12 Influence of different values of proportional gain of velocity controller K_p on compliance of Y-axis feed drive

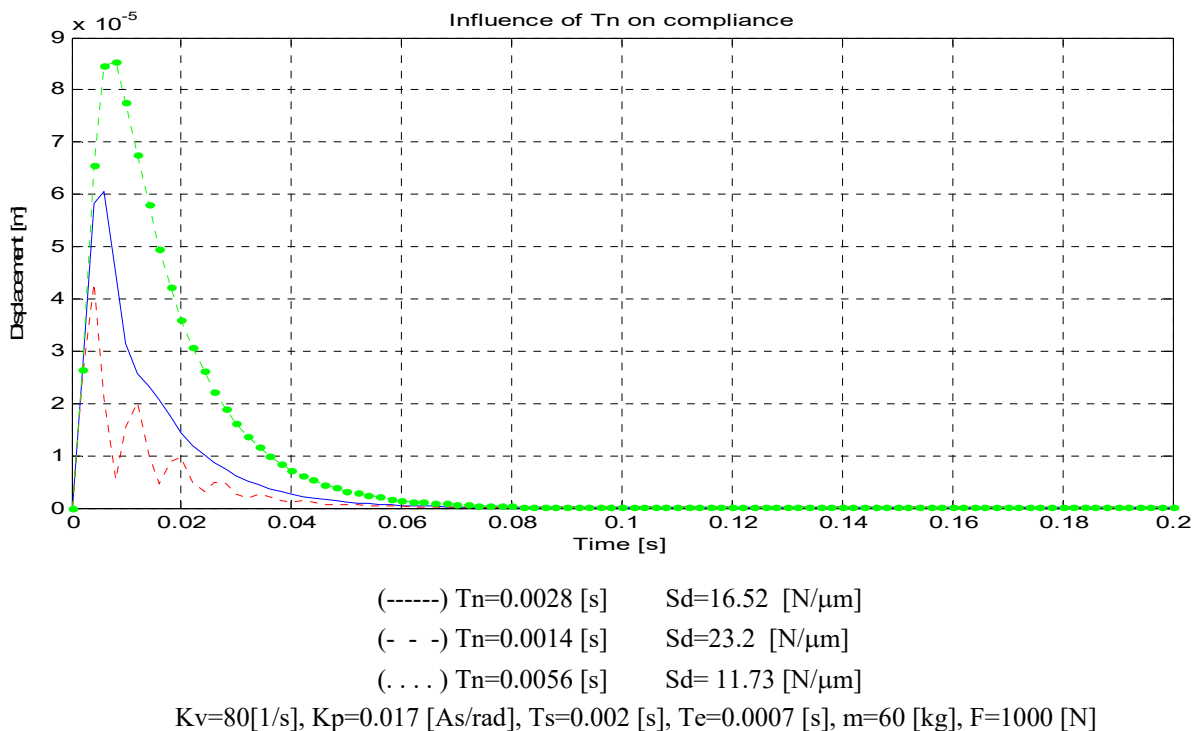

Fig. 13 Influence of different values of integral time of velocity controller T_n on compliance of Y-axis feed drive

The simulations have shown that by increasing the position loop gain K_v and the proportional gain of the velocity controller K_p , the dynamic stiffness increases. Also, by increasing the integral time of the velocity controller T_n , the mass of the moving elements m , the time constant of the current loop T_e and the sampling period T_s , the dynamic stiffness decreases (Table 1).

Table 1 Changes in the range of different parameters and influence of the change on the dynamic stiffness

changes in the range of	$K_v=40-160$ [1/s]	$K_p=0.0085-0.034$ [As/rad]	$T_n=0.0014-0.0056$ [s]
increase in %	400	400	400
changes of S_d [N/ μm]	15.89-17.71	7.87-36.7	23.2-11.73
change of S_d in %	+11.45	+466.33	-49.44
changes in the range of	$m=30-120$ [kg]	$T_e=0.00035-0.0014$ [s]	$T_s=0.001-0.004$ [s]
increase in %	400	400	400
changes of S_d [N/ μm]	19.59-14.71	18.94-12.9	17.14-15.8
change of S_d in %	-24.91	-31.47	-7.82

3. Multibody modelling and simulation of virtual CNC machine feed drive system with Matlab Sim Scape Toolbox

The MATLAB Sim Scape Toolbox allowed us to use the complete CAD model of the geometry of the machine tool (Fig.1) in the multibody modelling (Fig. 14 and Fig. 15), automatically calculating the selected properties of the feed drives.

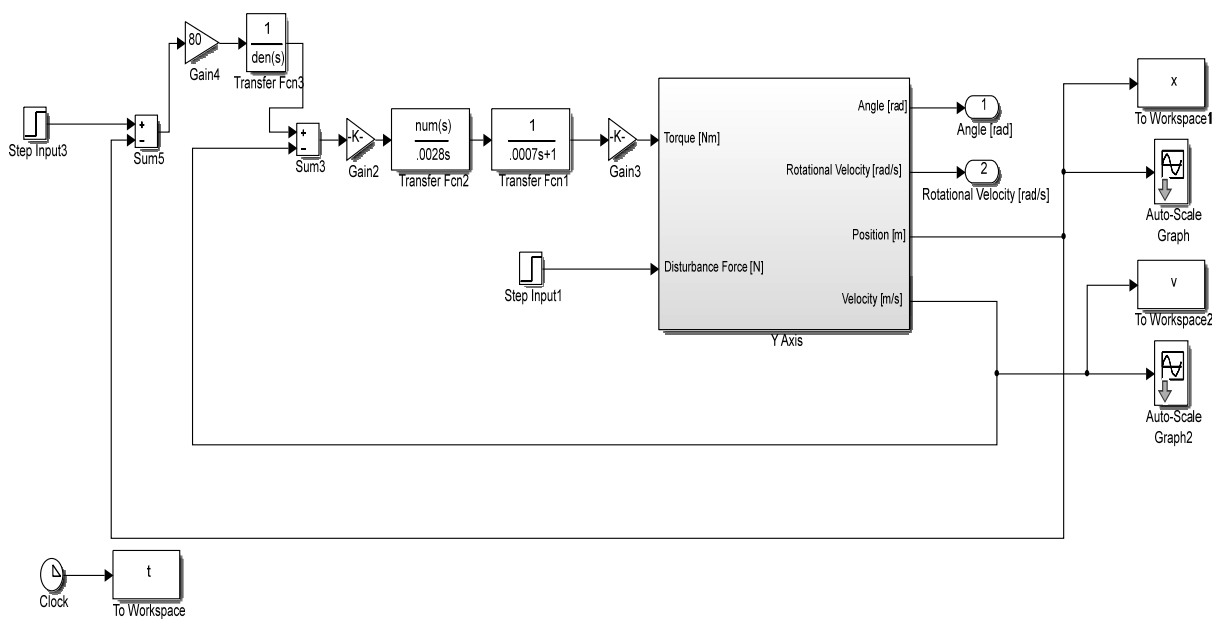

Fig.14 Multibody Sim Scape model of Y-axis feed drive of virtual CNC portal milling machine

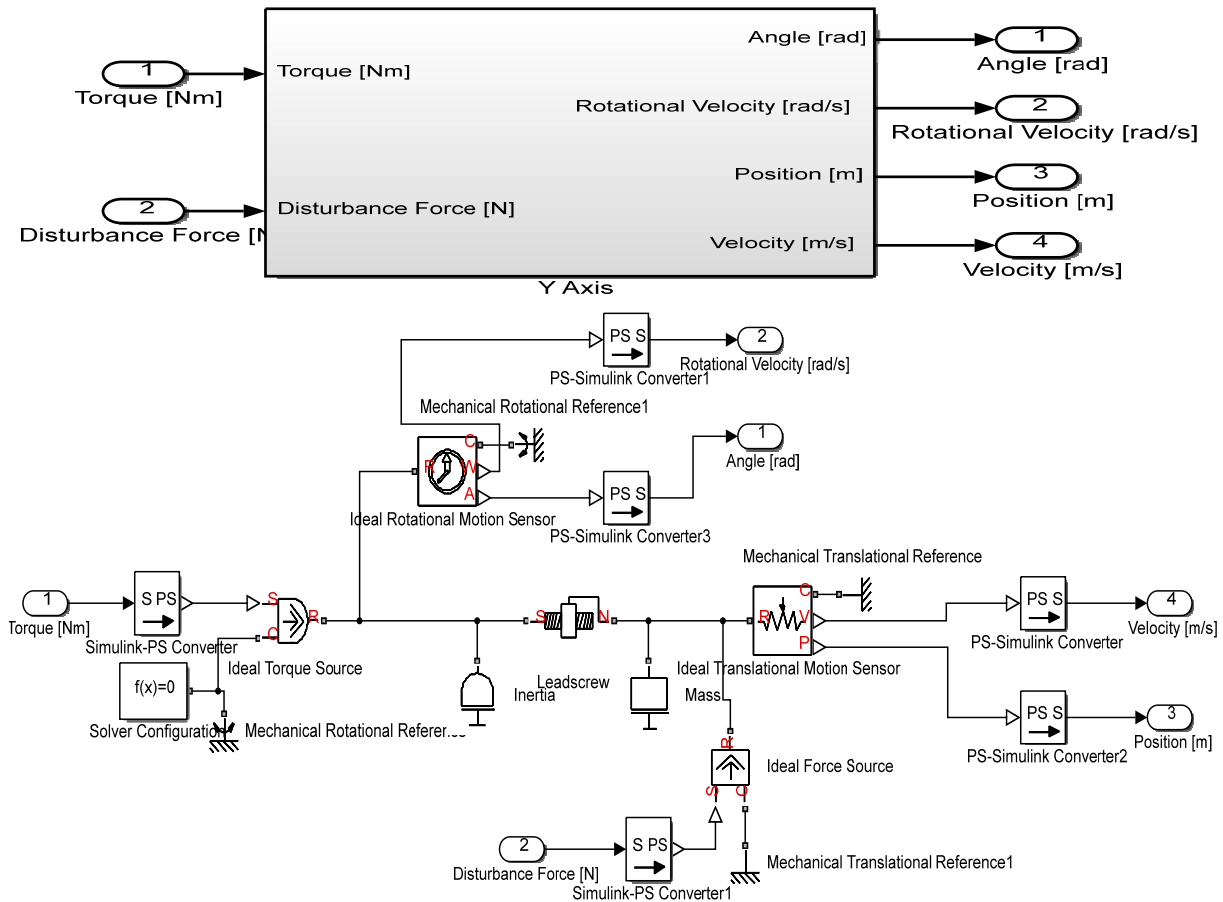

Fig. 15 Sim Scape model of mechanical elements of Y-axis feed drive of virtual CNC portal machine tool

In Fig. 16 and Fig. 17 comparisons between the Sim Scape model (multibody model) and the Simulink model (one mass model) of the position output over the step input, and the elasticity (displacement) output over the step disturbance force as input are given.

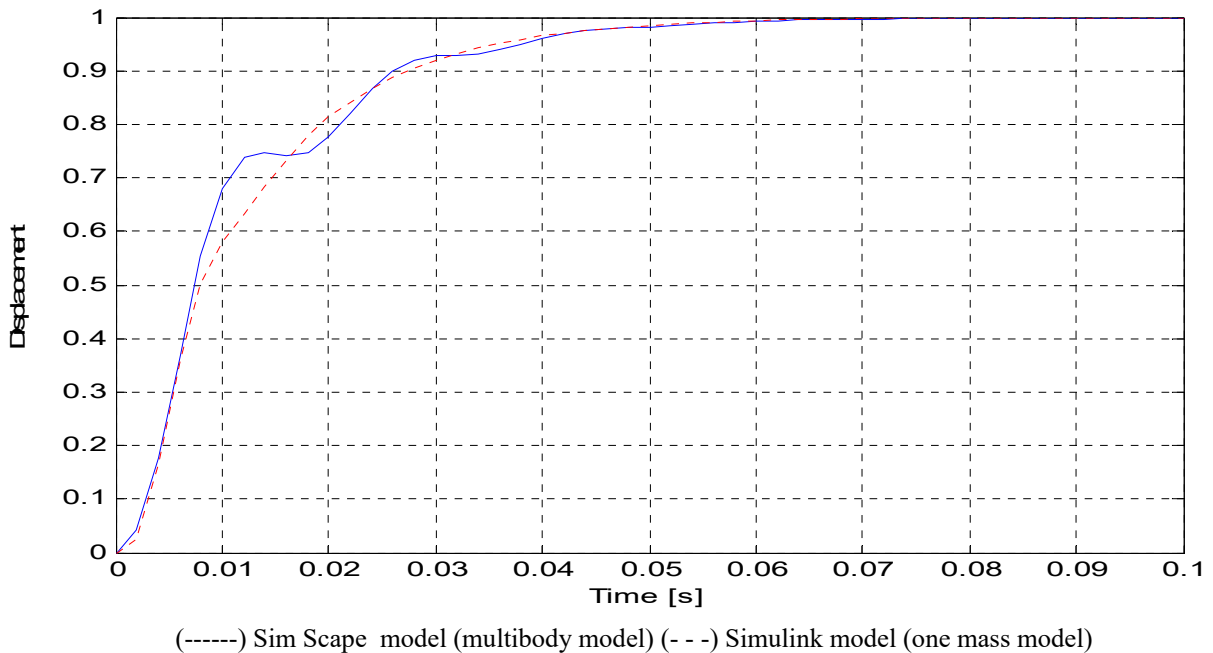

Fig. 16 Comparison of the position outputs from Sim Scape model (multibody model) and Simulink model (one mass model) of Y-axis feed drive of CNC portal milling machine and the step function for position as input

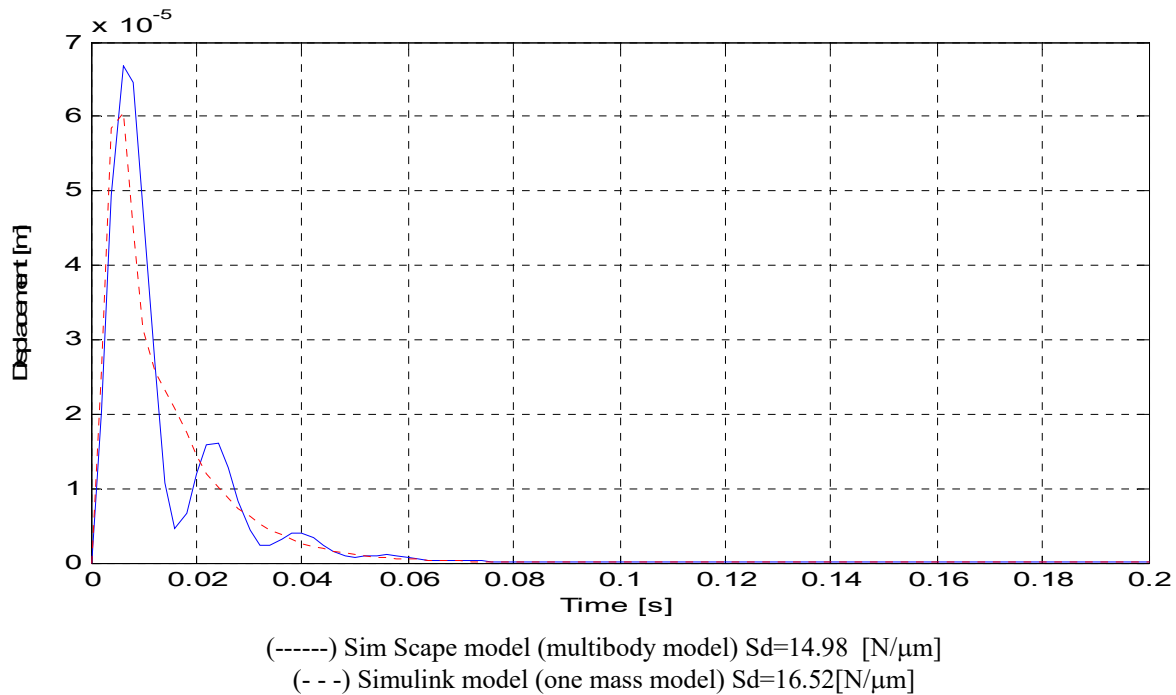

Fig. 17 Comparison of the elasticity (displacement) outputs from Sim Scape model (multibody model) and Simulink model (one mass model) of Y-axis feed drive of CNC portal milling machine and the step disturbance force of 1000 [N] as input

The difference of the dynamic stiffness obtained with the Sim Scape model (multibody model) $S_d=14.98$ [N/ μm] and the Simulink model (one mass model) $S_d=16.52$ [N/ μm] is 10.28%, which is completely acceptable.

The simulations and comparison of tracking errors in the Sim Scape model (multibody model) and the Simulink model (one mass model) showed that for lower sinus disturbance frequencies up to 60 Hz the tracking error is greater in the Sim Scape model (multibody model) (Figs. 18, 19 and 20), but at sinus disturbance frequencies higher than 60 Hz the tracking error is greater in the Simulink model (one mass model) (Fig. 21 and Fig. 22).

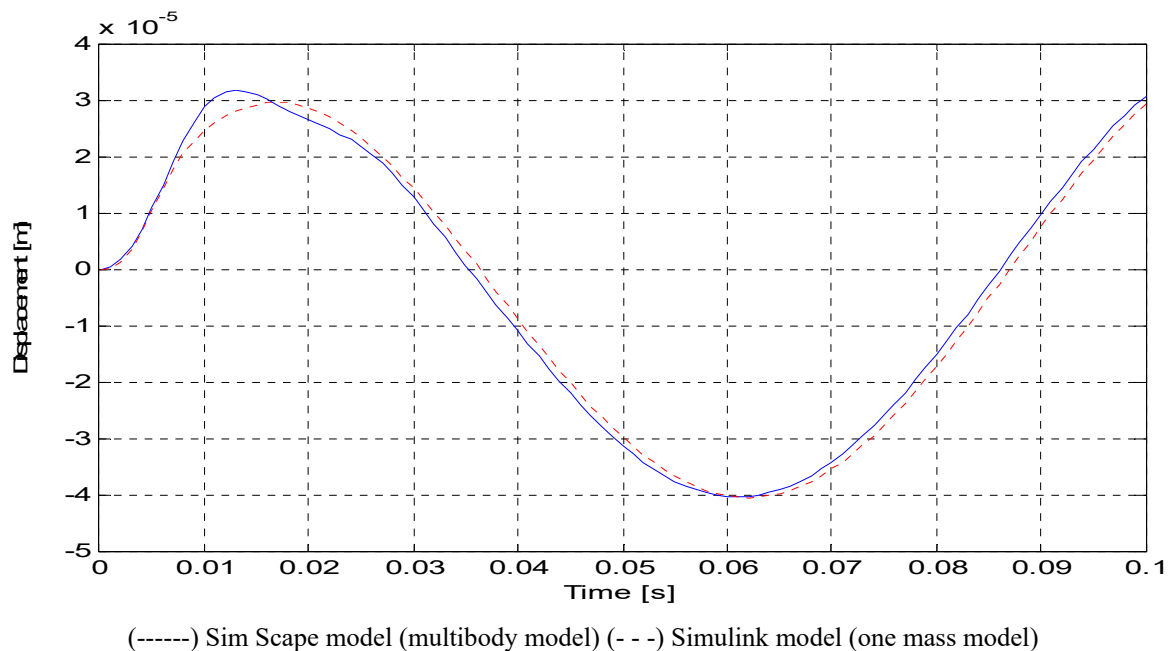

Fig. 18 Comparison of the tracking error from Sim Scape model (multibody model) and Simulink model (one mass model) of Y-axis feed drive of CNC portal milling machine and the sinus disturbance force with frequency of 10 [Hz], angular frequency of 62.8 [rad/s] and amplitude of 1000 [N] as input

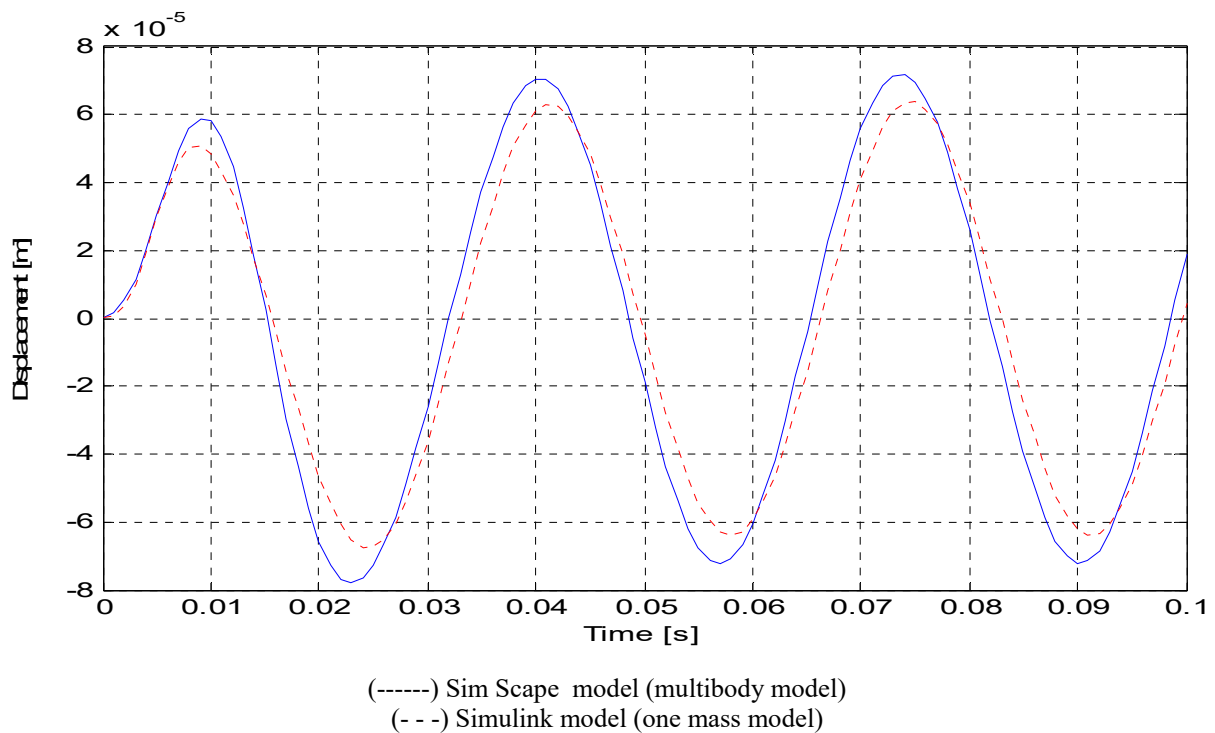

Fig. 19 Comparison of the tracking error from Sim Scape model (multibody model) and Simulink model (one mass model) of Y-axis feed drive of CNC portal milling machine and the sinus disturbance force with frequency of 30 [Hz], angular frequency of 188.4 [rad/s] and amplitude of 1000 [N] as input

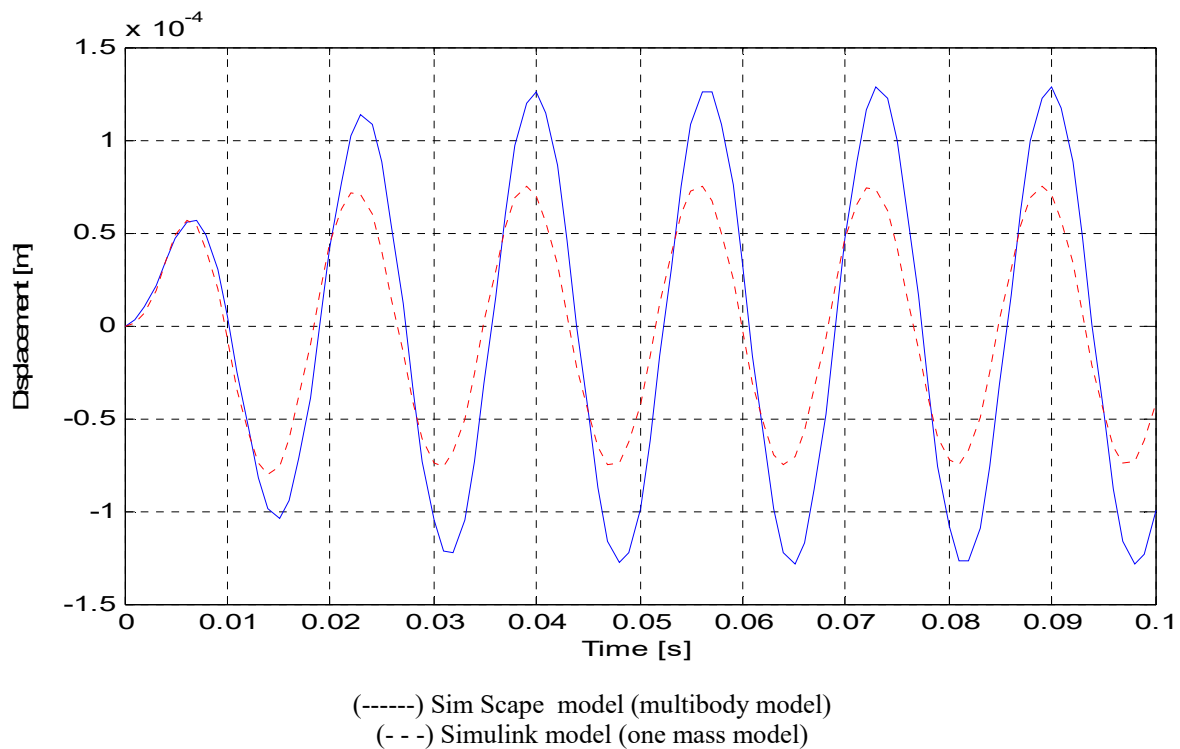

Fig. 20 Comparison of the tracking error from Sim Scape model (multibody model) and Simulink model (one mass model) of Y-axis feed drive of CNC portal milling machine and the sinus disturbance force with frequency of 60 [Hz], angular frequency of 376.8 [rad/s] and amplitude of 1000 [N] as input

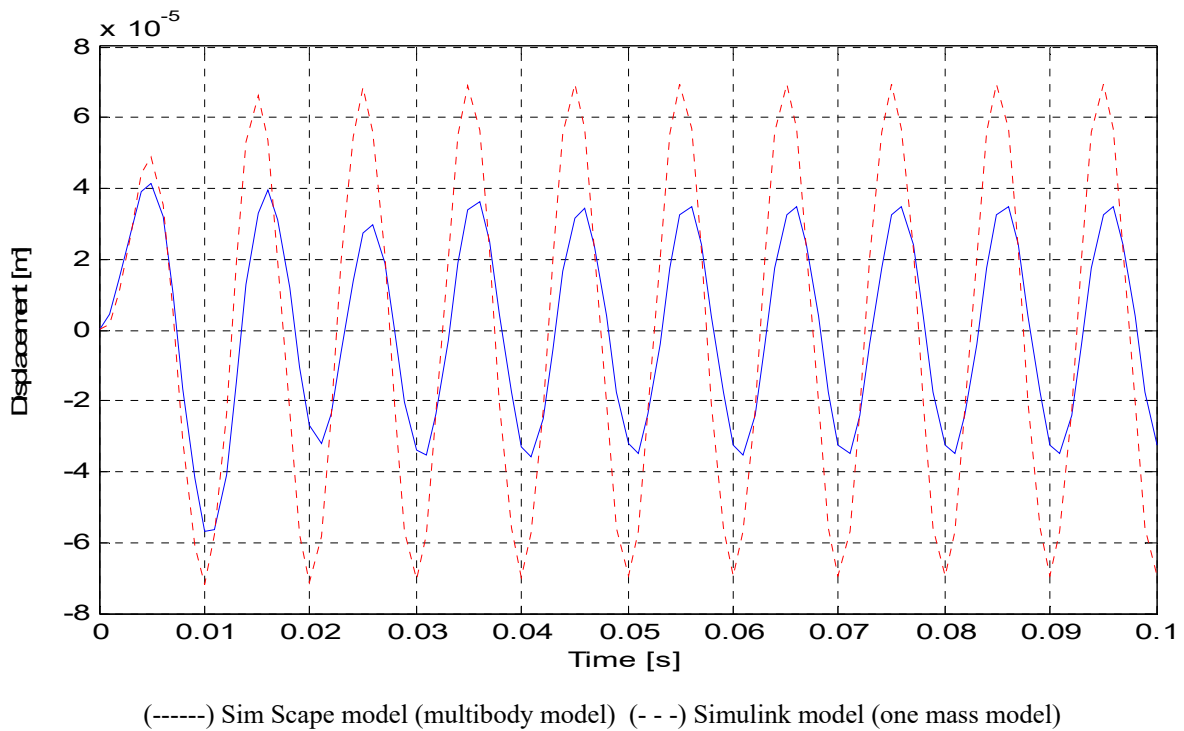

Fig. 21 Comparison of the tracking error from Sim Scape model (multibody model) and Simulink model (one mass model) of Y-axis of CNC portal milling machine and the sinus disturbance force with frequency of 100 [Hz], angular frequency of 628 [rad/s] and amplitude of 1000 [N] as input

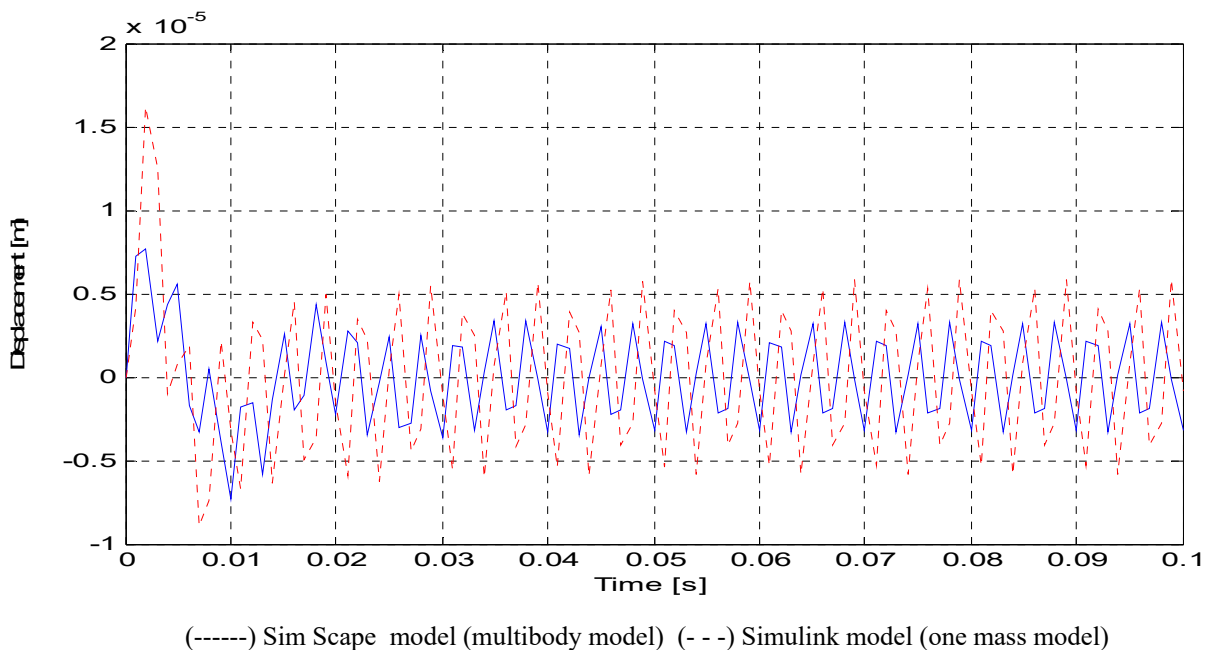

Fig. 22 Comparison of the tracking error from Sim Scape model (multibody model) and Simulink model (one mass model) of Y-axis of CNC portal milling machine and the sinus disturbance force with frequency of 300 [Hz], angular frequency of 1884 [rad/s] and amplitude of 1000 [N] as input

Using the CAD model of the virtual CNC machine tool and using the Sim Scape models of every machine tool feed drive (X, Y and Z axis) a complete model of the CNC portal machine tool feed drives is obtained (Fig. 23).

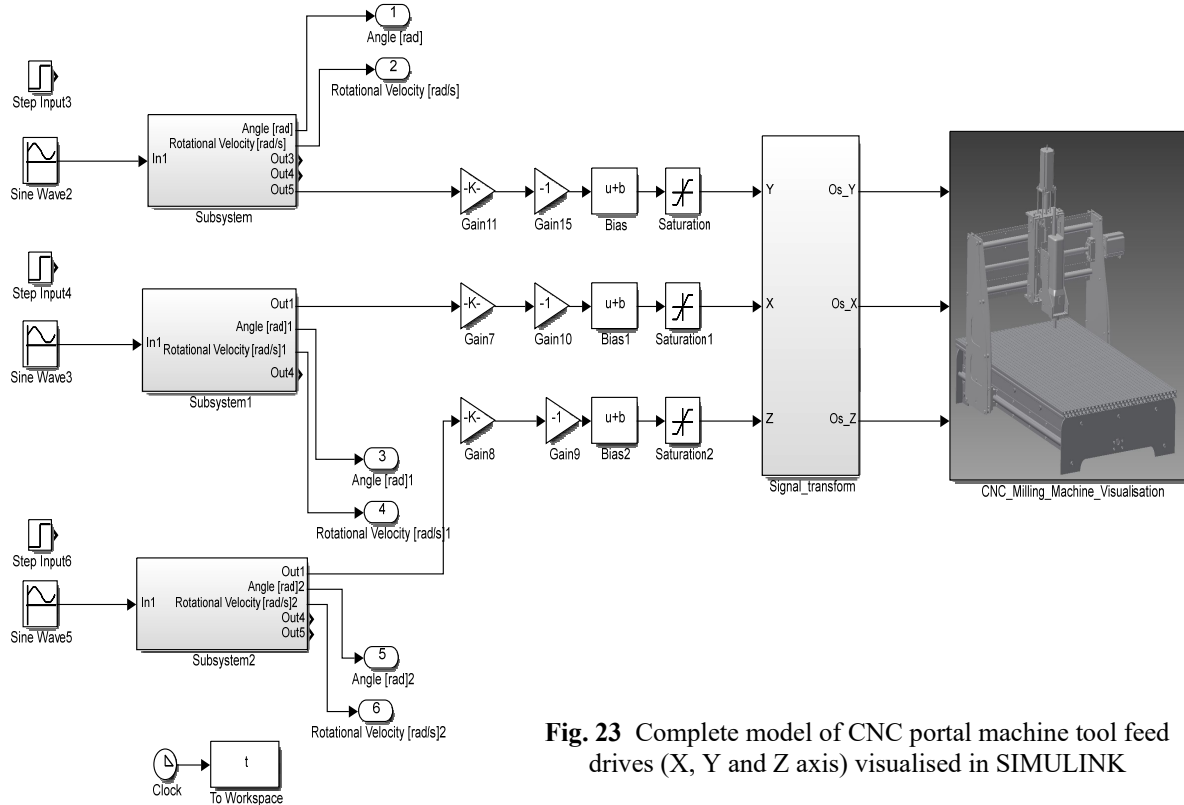

Fig. 23 Complete model of CNC portal machine tool feed drives (X, Y and Z axis) visualised in SIMULINK

A model of control of each axis in Simulink (Fig. 14) and a mechanical model of each axis in SimScape (Fig.15) are implemented in this model as subsystems.

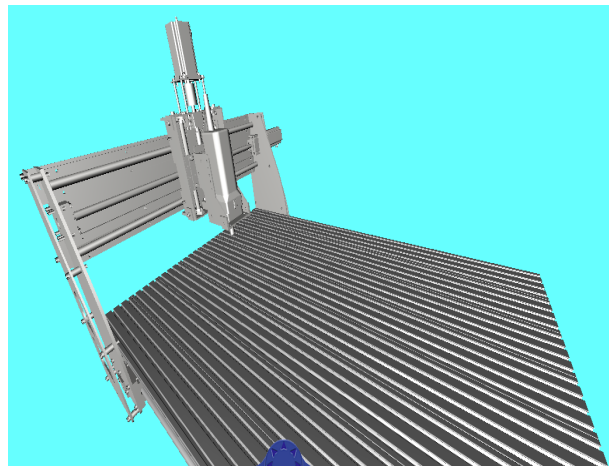

Fig. 24 Simple visualisation in SIMULINK of the complete model of CNC portal machine tool

3.1 Visualisation of the whole machine tool with all feed drives in the Virtual Reality system

The second phase of the study was the visualization of the whole machine tool using the CAD model of the machine tool (Fig. 1) and the models of the feed drives developed in Matlab-Simulink and Sim Scape (Figs.14,15 and 23) in the Virtual Reality system developed with the EON Studio software. The use of the EON studio software significantly improved the model and the visualization quality (Fig. 25)

The studied available literature did not give any example of the visualization of machine tools and their feed drives in the Virtual Reality system using the EON Studio software. So,

this paper shows that with this visualization it is possible to simulate the real operation of the whole CNC machine tool (contouring operations, changing tools, etc.).

4. Conclusion

The presented method of virtual modelling and simulation of the CNC machine tool feed drive enables designing, performing complex analyses, testing, optimisation and using different types of control structures for feed drives in a computer simulation environment. It significantly reduces the time of development and design of different construction variants of CNC machine feed drive systems and reveals real possibilities of the construction during a new machine design in the phase when possible changes are not economically critical. Also, it enables an effective optimization of the CNC machine tool feed design with respect to position accuracy, dynamic stiffness and control dynamics.

For a machine tool designer, a product designer or a manufacturing engineer, the virtual modelling and engineering evaluation system can help in increasing the precision of the machining process and decreasing the lead-time.

This whole study could be very useful to machine tool producers, because they could change their practice of making time consuming and very expensive real prototypes of CNC machine tools to creating virtual prototypes of machines.

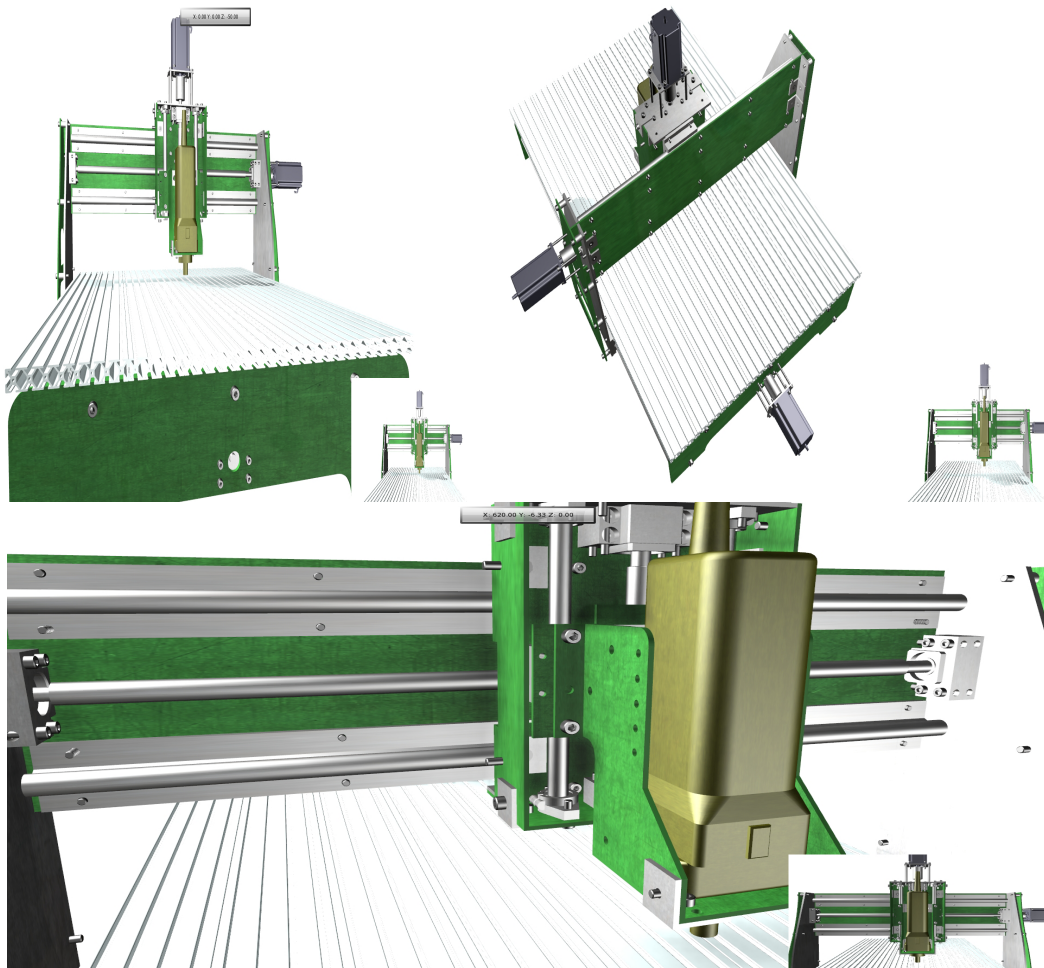

Fig. 25 Visualisation of whole CNC portal machine tool in EON studio software

Acknowledgments

This study was funded by the European Community's Research Infrastructure Action - grant agreement VISIONAIR 262044 - under the 7th Framework Programme.

REFERENCES

- [1] Owen J.V.: *Virtual manufacturing*, Manufacturing Engineering, 1997; 119: 84–90.
- [2] Radharamanan R.: *Virtual manufacturing: an emerging technology*. In: ASEE annual conference proceedings, 2002. p. 9957–67.
- [3] Mwinuka T.E., Mgwatu M.I.: Tool selection for rough and finish CNC milling operations based on tool-path generation and machining optimisation, *Advances in Production Engineering & Management*, Vol. 10, No. 1, 2015, pp. 18-26, ISSN 1854-6250, <http://dx.doi.org/10.14743/apem2015.1.189>.
- [4] Debevec M., Simic M., Herakovic N. (2014). Virtual Factory as an Advanced Approach for Production Process Optimization. *International Journal of Simulation Modelling*, Vol. 13, No. 1, p. 66-78
- [5] Čuš, F., Župerl, U., Surface roughness control simulation of turning processes, *Strojniški vestnik – Journal of Mechanical Engineering* 61(2015)4, DOI:10.5545/sv-jme.2014.2345, pp. 245-253.
- [6] Hrelja M., Klancnik S., Irgolic T., Paulic M., Jurkovic Z., Balic J., Brezocnik M.: Particle swarm optimization approach for modelling a turning process, *Advances in Production Engineering & Management*, Vol. 9, No. 1, 2014, pp. 21-30, ISSN 1854-6250, <http://dx.doi.org/10.14743/apem2014.1.173>.
- [7] Todorovic P., Vukelic D., Tadic B., Veljkovic D., Budak I., Macuzic I., Lalic B. (2014). Modelling of Dynamic Compliance of Fixture/Workpiece Interface. *International Journal of Simulation Modelling*, Vol. 13, No. 1, p. 54-65
- [8] Weck, M., Queins, M., Witt, S.: *Effektive Entwicklung von Werkzeugmaschinen*, VDI-Z Nr. 145 (2003), Springer-VDI-Verlag, Düsseldorf, 32-36.
- [9] Altintas Y., Brecher C., Weck M., Witt S.: *Virtual Machine Tool*, CIRP Annals - Manufacturing Technology Volume 54, Issue 2, 2005, Pages 115–138
- [10] Gross H., Hamann J., Wiegaertner G.: *Electrical Feed Drives in Automation: Basic, Computation, Dimensioning*, MCD Corporate Publishing, Erlangen and Munich, (2006). (In German)
- [11] Pandilov Z., Dukovski V., *Analytical Determination of the CNC Machines High-Speed Feed Drives Position Loop Gain*, *Applied Mechanics and Materials* Vol. 555 (2014) pp 505-510, Trans Tech Publications, Switzerland, ISSN: 1660-9336
- [12] Pandilov Z., Dukovski V.: *Computer aided optimal design of servo drives for CNC machine tools*, *Journal of Machine Engineering*, Vol.8, No.1, 2008, pp.77-83 (Edited by Jerzy Jedrzejewski), ISSN 1895-7595.
- [13] Ciglar D., Udiljak T., Klaić M., Mulc T.: *Design of portable carving machine*, 16th International Research/Expert Conference TMT 2012, Year 16, No1., Dubai, UAE, 10-12 September 2012, p. 531-534, ISSN 1840-4944.
- [14] Weck M.: *Machine Tools and Machining Systems, Volume 3, Mechatronics Systems: Feed Drives and Process Diagnosis*, Springer, (2006) (In German).
- [15] Pandilov Z., Dukovski V.: *Static and dynamic stiffness of the mechatronic position servo systems*, *Applied Mechanics and Materials* Vol. 332 (2013) pp 186-193, Trans Tech Publications, Switzerland, ISBN-13: 978-3-03785-733-5, (ISSN: 1660-9336)

Submitted: 07.4.2015

Accepted: 14.10.2015

Zoran Pandilov
University "Sv. Kiril i Metodij"-Skopje,
Faculty of Mechanical Engineering,
Karpos II b.b., P.O.Box 464, MK-1000,
Skopje, Republic of Macedonia
panzo@mf.edu.mk
Andrzej Milecki
Amadeusz Nowak
Filip Górski
Damian Grajewski
Poznan University of Technology, Faculty
of Mechanical Engineering and
Management, str. Piotrowo 3, PL-60-138,
Poznan, Poland
Damir Ciglar
Miho Klaić
University of Zagreb, Faculty of
Mechanical Engineering and Naval
Architecture, Ivana Lučića 5, HR-10002
Zagreb, Croatia
Tihomir Mulc
Domovinskog rata 1, 23000 Zadar, Croatia