

A New Approach Based on Instantaneous Power Theory for Improving the Performance of UPQC Under Unbalanced and Distortional Load Conditions

DOI 10.7305/automatika.2015.07.750
UDK 621.314.26:004.421

Original scientific paper

In order to deal with power quality problems under distortional and unbalanced load conditions, this paper presents a new control method for a four-wire three-phase unified power quality conditioner (UPQC) which is based on instantaneous power p-q theory. The proposed control approach is based on instantaneous power and is optimized by using a self-tuning filter (STF), without using any low-pass filters (LPFs) or phase locked loop (PLL), and without measuring load or filter currents. In this approach, the load and source voltages are used to generate the reference voltages of a series active power filter (APF) and source currents are used to generate the reference currents of a shunt APF. Therefore, the number of times that current is measured is reduced and system performance is improved. The performance of the proposed control approach is evaluated in terms of power factor correction, source neutral current mitigation, load balancing and mitigation of the current and voltage harmonics of distortional and unbalanced loads in a three-phase four-wire system. The results obtained by MATLAB/SIMULINK software show the effectiveness of the proposed control technique in comparison to the conventional p-q method.

Key words: Current harmonic mitigation, power quality, source neutral current mitigation, unified power quality conditioner (UPQC), voltage harmonic mitigation

Novi pristup za poboljšanje karakteristika UPQC-a tijekom nesimetričnih i distorzijskih uvjeta tereta temeljen na teoriji trenutne snage. U ovom radu prikazana je nova metoda upravljanja za trofazni četverožični UPQC (engl. unified power quality conditioner) temeljena na teoriji trenutne vrijednosti snage koja je prikladna za upravljanje tijekom distorzijskih i nesimetričnih uvjeta na teretu. Predloženo upravljanje temelji se na teoriji o trenutnoj radnoj i jalovoj snazi i optimirano je korištenjem samopodešavajućeg filtera, bez korištenja niskopropusnih filtera ili PLL-a i bez mjerenja struje tereta i filtera. Korišteni su naponi na teretu i napon izvora kako bi se generirala referentna vrijednost napona aktivnog filtera, a struje izvora koriste se za generiranje referentne vrijednosti struje aktivnog filtera. Na taj način smanjen je broj mjerenja struje i sustav ima bolje značajke. Uz predloženi sustav upravljanja testire su mogućnosti korekcije faktora snage, smanjenja neutralne struje izvora, balansiranja tereta, smanjenje harmonika u struji i naponu. Rezultati dobiveni pomoću MATLAB/SIMULINK-a pokazuju učinkovitost predloženog sustava upravljanja.

Ključne riječi: smanjenje harmonika u struji, kvaliteta energije, smanjenje neutralne struje izvora, UPQC, smanjenje harmonika u naponu

1 INTRODUCTION

The main power quality problems in three-phase four-wire systems include current harmonics, load unbalance, excessive null current, voltage harmonics, voltage sag, and voltage swell. Poor power quality results in a low power factor, low efficiency, and overheating of transformers and so on [1]. Furthermore, in distribution systems, the total load of system is rarely balanced, and this unbalance increases the null current in three-phase four-wire systems. Since the current components of fundamental frequency and the components of higher frequencies exist in null cur-

rent, they cause overheating when they flow in null wire [2]. By using more complicated and more advanced software and hardware in control systems, power quality has become one of the most important subjects for engineers of power electronics. So, to deal with power quality problem, many standards such as the IEEE519 standard have been presented by various standard organizations. Ideally, the current and voltage waveforms are in phase, power factor is equal to unity, and the consumed reactive power is equal to zero. Under such conditions, active power could be transmitted with maximum efficiency [3]. Passive fil-

ters were used in the past to deal with power quality problems. However, their limitations such as fixed compensation, possibility of resonating with source impedance, and problems of tuning passive filter parameters made the researchers to focus on active filters and hybrid filters [4-6].

The UPQC is one of the best solutions for solving voltage and current problems simultaneously [6, 7]. It was introduced for the first time by Fujita and Akagi in 1998 [7]. The structure of UPQC is similar to that of unified power flow controller (UPFC). The UPFC is used in transmission systems and its main goal is to control power flow in the fundamental frequency [8]. Whereas, UPQC is used in distribution systems to perform the functions of series and shunt APFs simultaneously. On the other hand, a distribution network may have DC components or harmonics and may be unbalanced. Therefore, the UPQC must carry out parallel and series compensation under such conditions [9]. The shunt and series APFs of UPQC are linked by a DC link. In UPQC, in contrast with UPFC, the series APF is connected to the source side and the shunt APF is connected to the load side. The shunt APF is used to compensate current distortions and to supply load reactive power [7]. Thus, the shunt APF of UPQC functions as a current source which injects the compensation current into the network. The series APF is used to compensate voltage fluctuations so, it is able to function as a voltage source which injects the compensation voltage into the network by a series transformer.

In the past few years, several control strategies have been presented in literature for determining the voltage and current reference signals. Some of the most common strategies include the p-q-r theory [10], improved single-phase instantaneous power theory [11], synchronous reference frame (SRF) theory [12], symmetric component transformation [13], $I\cos\varphi$ theory [14, 15], and some other innovative control methods [16, 17]. In [18], the one-cycle control approach (without calculating the reference) is used for controlling a three-phase four-wire UPQC. Among these control methods, the most important and the most common control methods are the p-q and SRF theories and so far some researches have been carried out to modify these two control approaches [19-21]. Although, these two strategies are based on balanced three-phase systems, they can be used for single phase systems too [22, 23]. In Some researches, these two control methods are combined to achieve a better performance for UPQC [24, 25]. In most of these methods, a low pass filter (LPF) or a high pass filter (HPF) is used for separating the harmonic components from fundamental component.

In this paper, the proposed control approach which is based on instantaneous power p-q theory is optimized by using an STF, without using any LPFs or any phase locked loops (PLLs). The performance of the proposed system

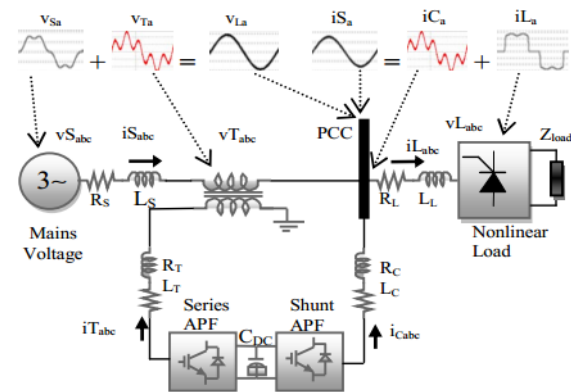

Fig. 1. The basic structure of unified power quality conditioner (UPQC) [25].

is tested by using MATLAB/SIMULINK software in cases such as power factor correction, source neutral current mitigation, load balancing, and reducing current and voltage harmonics of distortional and unbalanced loads in a three-phase four-wire system. Simulation results show the competence and effectiveness of the proposed control method in comparison to the conventional p-q method.

2 UPQC

Because of its capability in removing harmonics and in simultaneously compensating the voltage and current, the UPQC improves the power quality. Almost all papers about UPQC show that it could be used for solving all the power quality problems [26-30]. Fig. 1 shows the basic structure of a UPQC which consists of a shunt and a series APF. The shunt APF is used for absorbing current harmonics, compensating reactive power and regulating dc-link voltage. The main purpose of using the series APF is to remove harmonics of the source voltage. Furthermore, the series APF is capable of compensating voltage unbalance and harmonics at the point of common coupling in consumer side [28].

3 THE PROPOSED METHOD BASED ON P-Q THEORY

The p-q theory is based on a set of instantaneous powers defined in time domain. In this theory, there is no limitation in voltage or current waveforms and it could be used for general waveforms of three-phase voltages and currents in a three-phase systems with or without neutral wire. The p-q theory could be used for compensating the existing harmonics in source voltages or load current [31]. To compensate the current harmonics, first, distortional currents are transformed to the Clarke's reference frame. Then, by calculating instantaneous powers and letting them flow in an

LPF, the harmonic and fundamental components are separated and reference currents are generated for hysteresis band controller. Conventional control systems usually include three main parts: shunt APF control, PLL and series APF control [19-23]. In conventional control systems, a PLL separates the positive sequence component from the unbalanced and distortional voltage of the source. In the proposed method, a STF is used to separate the positive sequence voltage from harmonic voltage of the source. Also, instead of using LPFs and HPFs, the STF is used for separating the fundamental component of current. So, the proposed approach has three major parts: a STF, a shunt APF and a series APF.

3.1 STF

Hong-Sock has studied integral in the synchronous reference frame and has shown that:

$$V_{xy}(t) = e^{j\omega t} \int e^{-j\omega t} U_{xy}(t) dt \quad (1)$$

Where, U_{xy} and V_{xy} are instantaneous signals respectively before and after the integration in the synchronous reference frame [32]. By applying the Laplace transform on (1), the equation of the transfer function $H(s)$ is expressed as:

$$H(s) = \frac{V_{xy}(s)}{U_{xy}(s)} = \frac{s + j\omega}{s^2 + \omega^2} \quad (2)$$

In order to obtain a self-tuning filter (STF) with a cut off frequency from the transfer function $H(s)$, a constant parameter k is introduced [33]. Thus, By using this parameter, $H(s)$ can be written as follows:

$$H(s) = \frac{V_{xy}(s)}{U_{xy}(s)} = \frac{k(s + k) + j\omega_n}{(s + k)^2 + \omega_n^2} \quad (3)$$

By adding a constant parameter k to $H(s)$, the amplitude of the transfer function is limited and is equal to the amplitude of frequency component (ω_n). In addition, the phase delay is zero for the cut off frequency. By replacing the input signals $U_{xy}(s)$ by $x_{\alpha\beta}(s)$ and the output signals $V_{xy}(s)$ by $\hat{x}_{\alpha\beta}(s)$, the following expressions can be obtained:

$$\hat{x}_\alpha = \left(\frac{k}{s} [x_\alpha(s) - \hat{x}_\alpha(s)] - \frac{\omega_n}{s} \cdot \hat{x}_\beta(s)\right) \quad (4)$$

$$\hat{x}_\beta = \left(\frac{k}{s} [x_\beta(s) - \hat{x}_\beta(s)] - \frac{\omega_n}{s} \cdot \hat{x}_\alpha(s)\right) \quad (5)$$

Where, ω_n is the desired output frequency, and k is the filter gain. The higher the value of k , the higher the accuracy of extracting the desirable component is. Also, when

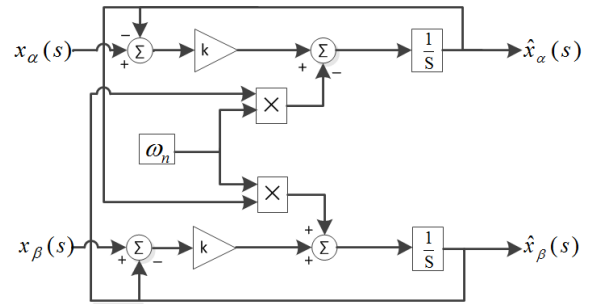

Fig. 2. The block diagram of STF

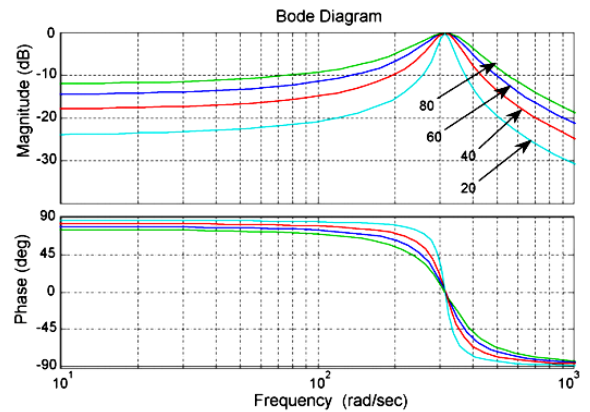

Fig. 3. Bode diagram for the STF versus pulsation for different values of the parameter k ($f_c=50\text{Hz}$) [33].

the value of k decreases, the transient duration increases. $x_{\alpha\beta}(s)$, and $\hat{x}_{\alpha\beta}(s)$ may also be either voltage or current signals before and after filtering respectively. So, by using a STF, voltage and current distortional signals can be obtained without changing the amplitude and phase delay. According to (4) and (5), the block diagram of an STF is shown in Fig. 2 [33].

Fig. 3 shows the frequency response of the STF versus different values of the parameter k for $f_c = 50\text{Hz}$. At 50Hz, the phase angle of bode diagram is null, which means that the two input and output signals are in phase either k . Also the phase shift for the other frequencies is shown. On the other hand, it is observed from Fig. 3 that $|H(s)| = 0\text{dB}$ at $f_c = 50\text{Hz}$. The rate of amplitude changes for the other frequencies is shown in Fig. 3 [33].

3.2 Reference voltage signal generation of the series APF

The proposed control method which is based on p-q theory has been used for solving all the problems related to the power quality including source voltage harmonics, unbalanced voltages, voltage sag and swell. In the proposed approach, by using (6), first the measured voltages

of source are transferred to the $\alpha-\beta-o$ coordinates. Under the harmonic voltages condition, instantaneous voltages of source ($v_{S\alpha}$ and $v_{S\beta}$) contain two components; harmonic and mean component, the latter contains the positive sequence. As it was stated in (7) and (8), the source voltages in $\alpha-\beta-o$ coordinates contains harmonic and mean components and the fundamental component of these voltages are separated from harmonic components by the STF.

$$\begin{bmatrix} v_{S0} \\ v_{S\alpha} \\ v_{S\beta} \end{bmatrix} = \sqrt{\frac{2}{3}} \begin{bmatrix} \frac{1}{\sqrt{2}} & \frac{1}{\sqrt{2}} & \frac{1}{\sqrt{2}} \\ 1 & -\frac{1}{2} & -\frac{1}{2} \\ 0 & \frac{\sqrt{3}}{2} & -\frac{\sqrt{3}}{2} \end{bmatrix} \begin{bmatrix} v_{Sa} \\ v_{Sb} \\ v_{Sc} \end{bmatrix} \quad (6)$$

$$v_{S\alpha} = \hat{v}_{S\alpha} + \tilde{v}_{S\alpha} \quad (7)$$

$$v_{S\beta} = \hat{v}_{S\beta} + \tilde{v}_{S\beta} \quad (8)$$

when the voltages of the three phases are unbalanced, it will be met in $\alpha\beta$ axis. Therefore the $v_{S\alpha}$ and $v_{S\beta}$ components will not have equal amplitudes in $\alpha-\beta-o$ coordinates. On the other hand, despite of extreme unbalance between two input signals, the STF, will create always two equal magnitude sine-waves according to following equation:

$$\frac{x_{\alpha}(s) + x_{\beta}(s)}{2} = \hat{x}_{\alpha}(s) = \hat{x}_{\beta}(s) \quad (9)$$

Therefore, to generate the reference voltages, first $\hat{v}_{S\alpha}(s)$ and $\hat{v}_{S\beta}(s)$ with unity amplitudes are obtained. Then the reference voltages in abc coordinates are calculated by (6), where G is the desired maximum phase voltage value.

$$\begin{bmatrix} v_{La}^* \\ v_{Lb}^* \\ v_{Lc}^* \end{bmatrix} = \sqrt{\frac{2}{3}} G \begin{bmatrix} 1 & 0 \\ -\frac{1}{2} & \frac{\sqrt{3}}{2} \\ -\frac{1}{2} & -\frac{\sqrt{3}}{2} \end{bmatrix} \begin{bmatrix} \hat{v}_{S\alpha} \\ \hat{v}_{S\beta} \end{bmatrix} \quad (10)$$

The three phase load reference voltages (v_{Labc}^*) are compared to the distortional voltages of load side (v_{Labc}) and the errors are processed by the PWM controller to produce required signals for IGBT switches of the series APF.

The voltage sag or swell compensation may include absorbing/injecting real power from/to supply line. Therefore, real powers of series and shunt APFs must be balanced. In order to make the dc-link voltage fixed, the absorbed and injected real powers by series and shunt APFs must be equal to injected and absorbed powers by shunt APF respectively [34]. The series APF control is shown in Fig. 4.

3.3 Reference voltage signal generation of the shunt APF

The shunt APF is used for compensating harmonics, load unbalance and reactive power generated by nonlinear load. The p-q theory is used to control the shunt APF. In this theory, voltages and currents are transferred to $\alpha-\beta-o$ coordinates by (6) and (11).

$$\begin{bmatrix} i_{S0} \\ i_{S\alpha} \\ i_{S\beta} \end{bmatrix} = \sqrt{\frac{2}{3}} \begin{bmatrix} \frac{1}{\sqrt{2}} & \frac{1}{\sqrt{2}} & \frac{1}{\sqrt{2}} \\ 1 & -\frac{1}{2} & -\frac{1}{2} \\ 0 & \frac{\sqrt{3}}{2} & -\frac{\sqrt{3}}{2} \end{bmatrix} \begin{bmatrix} i_{Sa} \\ i_{Sb} \\ i_{Sc} \end{bmatrix} \quad (11)$$

The currents transferred to the Clark's system enter the STF which is set to fundamental frequency. The STF output will be the fundamental current component ($\hat{i}_{S\alpha}$ and $\hat{i}_{S\beta}$) which will contain the fundamental component of active and reactive powers. To fully compensate the reactive power, the fundamental component of reactive power obtained from (12) must be subtracted as a current component, from current fundamental components ($\hat{i}_{S\alpha}$ and $\hat{i}_{S\beta}$).

Considering the switching loss (P_{Loss} , voltage fluctuation would be a good index that these fluctuations could be converted into a current by using a proportional-integral (PI) controller. This current must be injected into main axis. Hence For DC voltage regulation, voltage of DC link is compared with reference voltage (V_{DC}^*), and then is injected to into main axis by PI and it doesn't need any external supply.

On the other hand, when the load is unbalanced, there will be current in neutral wire. The total power of zero sequence component will be obtained from (13). To decrease the neutral current, the total zero sequence power must be supplied by shunt APF and this index must also be injected into main axis. As it is stated in (14), if is needed to fully compensate both the zero sequence component and reactive power, $i'_{S\alpha}$ and $i'_{S\beta}$ are the reference injected currents which must be injected into $\alpha-\beta$ axes. As it is stated in (15) and (16), by injecting these currents into $\alpha-\beta$ axes, the reference currents $i_{S\alpha}^*$ and $i_{S\beta}^*$ for shunt APF are obtained. Then the reference currents in abc coordinates are calculated by (17).

$$\hat{q} = \hat{i}_{S\beta} \hat{v}_{S\alpha} - \hat{i}_{S\alpha} \hat{v}_{S\beta} \quad (12)$$

$$p_0 = v_{S0} i_{S0} \quad (13)$$

$$\begin{bmatrix} i'_{S\alpha} \\ i'_{S\beta} \end{bmatrix} = \frac{1}{\hat{v}_{S\alpha}^2 + \hat{v}_{S\beta}^2} \begin{bmatrix} \hat{v}_{S\alpha} & -\hat{v}_{S\beta} \\ \hat{v}_{S\beta} & \hat{v}_{S\alpha} \end{bmatrix} \begin{bmatrix} P_{Loss} + p_0 \\ -\hat{q} \end{bmatrix} \quad (14)$$

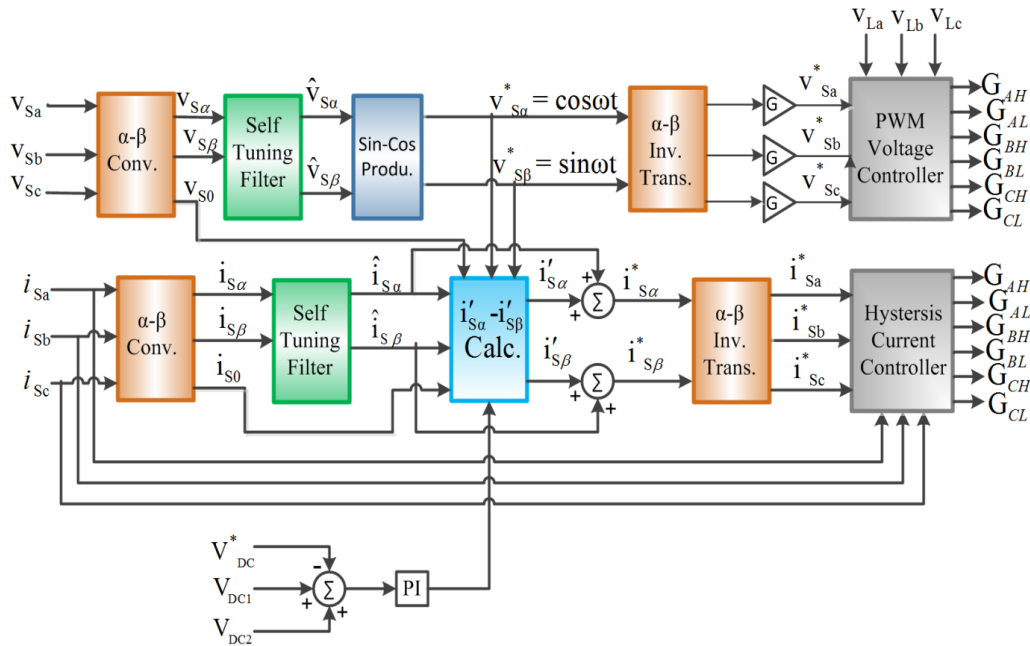

Fig. 4. The block diagram of proposed control method for UPQC.

$$i_{S\alpha}^* = \hat{i}_{S\alpha} + i'_{S\alpha} \tag{15}$$

$$i_{S\beta}^* = \hat{i}_{S\beta} + i'_{S\beta} \tag{16}$$

$$\begin{bmatrix} i_{Sa}^* \\ i_{Sb}^* \\ i_{Sc}^* \end{bmatrix} = \sqrt{\frac{2}{3}} \begin{bmatrix} 1 & 0 \\ -\frac{1}{2} & \frac{\sqrt{3}}{2} \\ -\frac{1}{2} & -\frac{\sqrt{3}}{2} \end{bmatrix} \begin{bmatrix} i_{S\alpha}^* \\ i_{S\beta}^* \end{bmatrix} \tag{17}$$

The reference currents, i_{Sa}^* , i_{Sb}^* and i_{Sc}^* are calculated in order to compensate neutral currents, reactive and harmonic currents in the load. These reference source currents are compared to measured currents of the source and errors resulted from this comparison are received by a hysteresis band controller to produce required switching signals of shunt APF.

4 SIMULATION RESULTS

In this study, the proposed control method for UPQC which is based on p-q theory and is used for compensating distortional and unbalanced load currents under the conditions of distortional and unbalanced source voltages is evaluated by MATLAB software. The load used in simulations is a combination of a three-phase rectifier load and a single-phase rectifier load. The single-phase rectifier load is used to create load unbalance in phase ‘a’. Also, the

source voltage contains odd harmonics up to the order of 17. Furthermore, the third harmonic and its multiples are not considered in simulations. Because the third harmonic and its multiples will be compensated by the connections of transformers and often there is no need to compensate them by the series APF. Passive filters with R and C are used to remove the switching ripples in voltage and current waveforms. The values of simulated parameters are given in Table 1.

4.1 The performance of UPQC in load balancing, correcting power factor and compensating current and voltage harmonics

The UPQC responses in load balancing, correcting power factor and compensating current and voltage harmonics are shown in Fig. 5. Fig. 5 (a) shows the harmonic voltages before compensation. It could be seen from Fig. 5 (c) that by injecting compensating voltage into system, the series APF removes source voltage harmonics and generates sinusoidal voltages for the load. Voltages injected by the series APF are shown in Fig. 5 (b). As voltage harmonics is removed by the series APF, load voltage THD decreases from 11.16% to 1.52%. Voltage harmonics spectrums before and after compensation are shown in Fig. 6 (a) and Fig. 6 (b) respectively. On the other hand, Fig. 5 (d) shows the load harmonic and unbalanced current before compensation. It could be seen from Fig. 5 (f) that by injecting compensating currents into system, the shunt APF makes the source current sinusoidal and balanced and

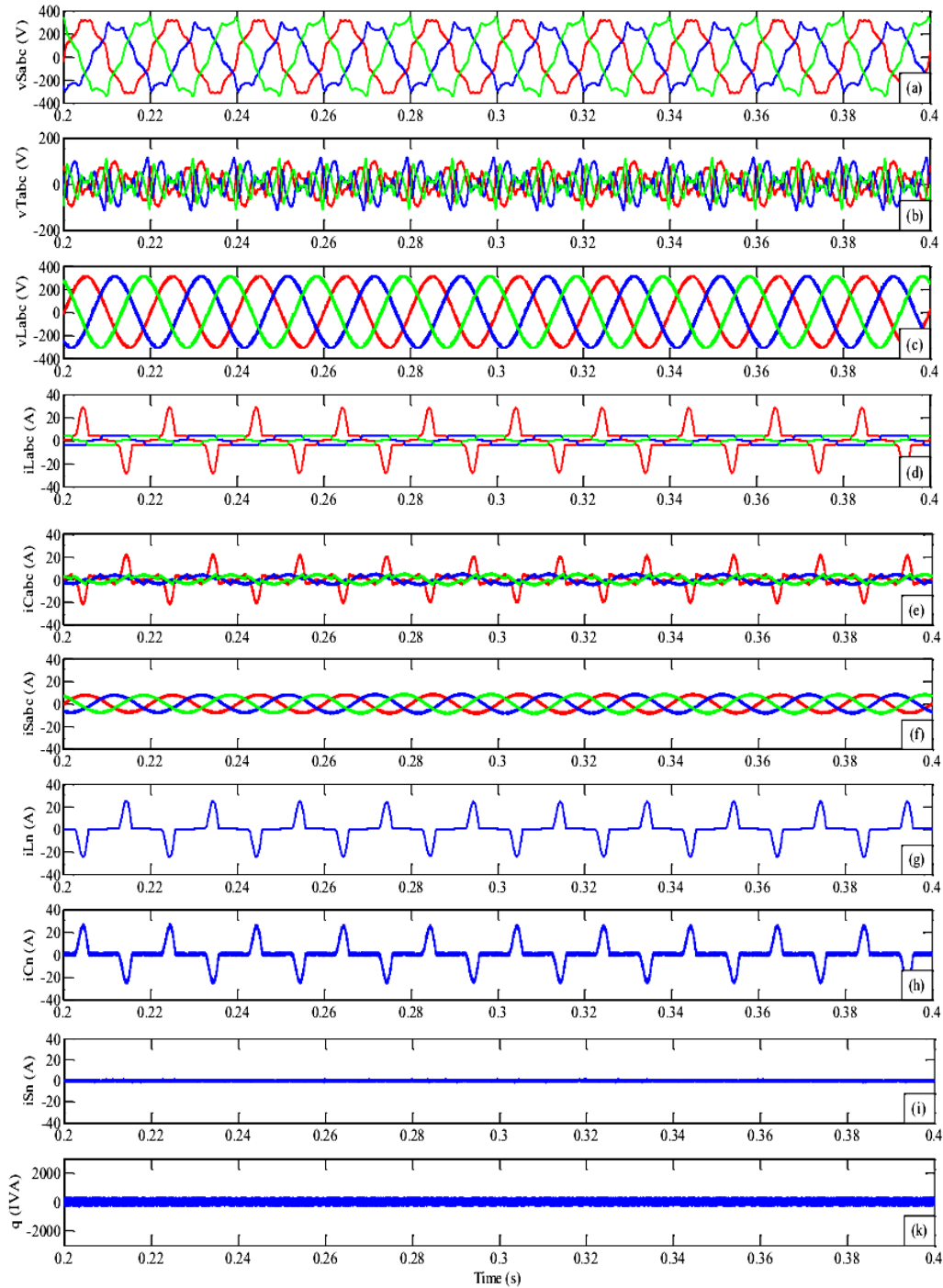

Fig. 5. Simulation results for the proposed control approach for: (a) source distortional voltages, (b) voltages injected by transformer (c) load voltages (d) unbalanced and nonlinear load currents (e) currents injected by compensator (f) Source currents (g) load neutral current (i) neutral current injected by compensator (h) instantaneous reactive power.

decreases source current THD from 28.72% to 2.37%. The currents injected by shunt APF into the network are shown in Fig. 5 (e). Also the current harmonic spectrum of phase

'a' of the source before and after compensation, are shown in Fig. 6 (c) and Fig. 6 (d) respectively. It could be seen from Fig. 5 (g) that the current through neutral wire before

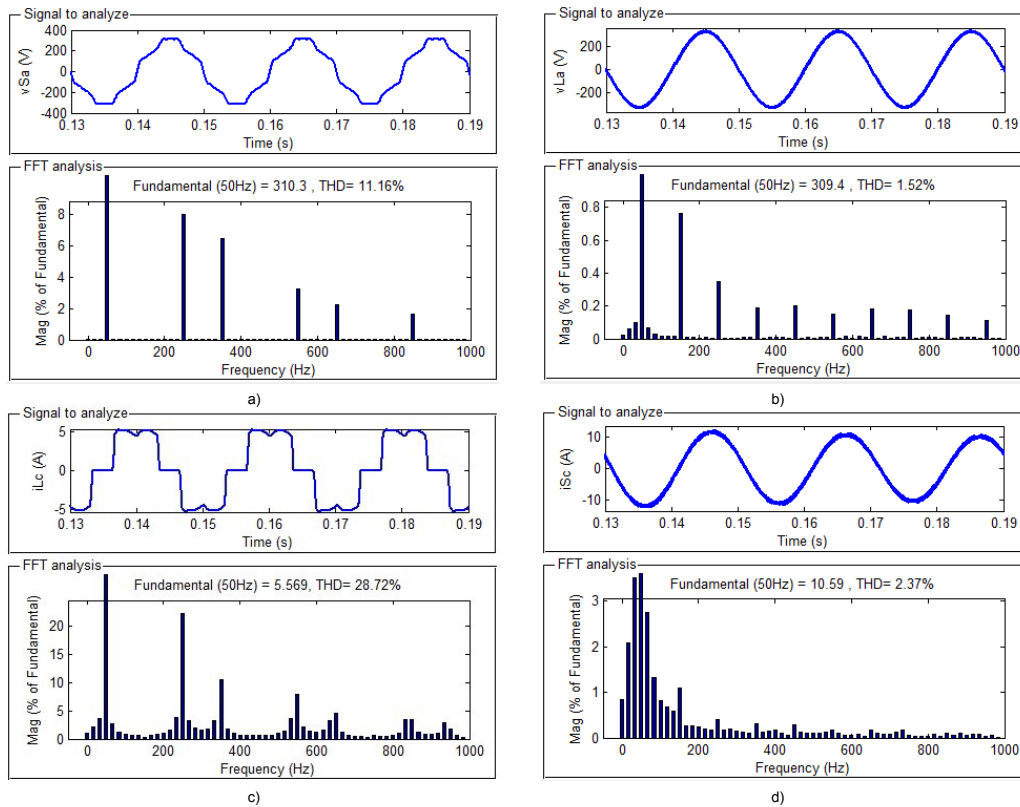

Fig. 6. (a) load voltage and its harmonic spectrum before compensation, (b) load voltage and its harmonic spectrum after compensation, (c) load current and its harmonic spectrum before compensation, (d) load current and its harmonic spectrum after compensation

Table 1. System parameters

| | Parameters | | Values |
|------------|----------------------------|------------|--------------|
| Source | Voltage | V_{Sabc} | 380 V |
| | Frequency | f | 50 Hz |
| Load | 3-Phase ac Line Inductance | L_{abc} | 2 mH |
| | 1-Phase ac Line Inductance | L_{La1} | 1 mH |
| | 3-Phase dc Inductance | L_{dc3} | 10 mH |
| | 3-Phase dc Resistor | R_{dc3} | 100 Ω |
| | 1-Phase dc Resistor | R_{dc1} | 50 Ω |
| | 1-Phase dc Capacitor | C_{dc1} | 240 μf |
| dc-link | Voltage | V_{dc} | 700 V |
| | Capacitor | C_1/C_2 | 2200 μF |
| Shunt APF | Ac Line Inductance | L_{Cabc} | 1 mH |
| | Filter Resistor | R_{Cabc} | 5 Ω |
| | Filter Capacitor | C_{Cabc} | 4.7 μF |
| | Hysteresis Band | h | 0.5 A |
| Series APF | Ac Line Inductance | L_{Sabc} | 0.6 mH |
| | Filter Resistor | R_{Sabc} | 5 Ω |
| | Filter Capacitor | C_{Sabc} | 26 μf |
| | Switching Frequency | f_{PWM} | 15 kHz |
| STF | Factor k In STF | k | 60 |

compensation is equal to 26.6 A. When the neutral compensating current is injected by the shunt APF, the neutral current of source decreases to zero. The neutral compensating current injected by shunt APF and source neutral current are shown in Fig. 5 (h) and Fig. 5 (i) respectively. As UPQC enters the circuit, the whole reactive power of load is supplied by shunt APF and voltages and currents of source become in phase and the load just derives reactive power from source. Fig. 5 (k) shows the reactive power derived from the source which has an amplitude equal to zero.

4.2 Performance of UPQC During a Sudden Increase of Load

In this section, to investigate the dynamic response of UPQC and to see how it enters the circuit, first it is assumed that UPQC is not in the circuit. As it could be seen from Fig. 7 (a) and Fig. 7 (c), source contains distorted unbalanced voltages and load derives unbalanced harmonic currents from the source. At $t=0.1s$, the UPQC enters the circuit and shunt and series APFs start the compensation. Fig. 7 (b) shows that when UPQC enters the circuit, series

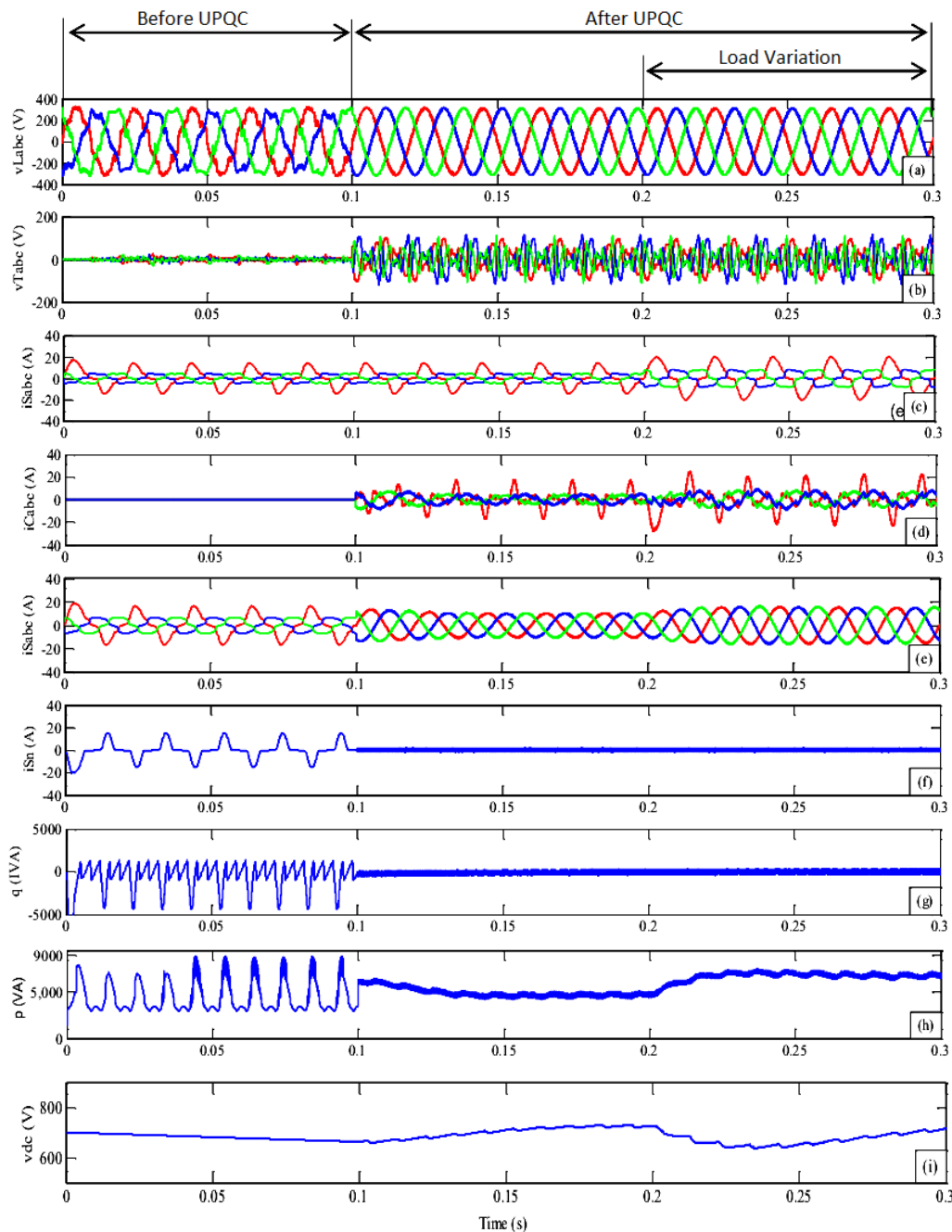

Fig. 7. The results of UPQC performance while operating. (a) load voltages, (b) voltages injected by the series transformers (c) load currents (d) source currents (e) the injected compensating currents (f) source neutral current (g) instantaneous reactive power (h) instantaneous active power (i) dc link voltage.

APF immediately inject compensating voltages into the network and make the load voltage sinusoidal. Also, Fig. 7 (d) shows the currents generated by shunt APF which make the currents derived from the network balanced and sinusoidal. The performance of UPQC in compensating the

neutral source current and load reactive power is shown in Fig. 7 (f) and Fig. 7 (h), respectively.

In order to show the UPQC performance during a sudden change in the load, when system is operating, the load is suddenly increased at $t=0.2s$. As it is shown in Fig. 7,

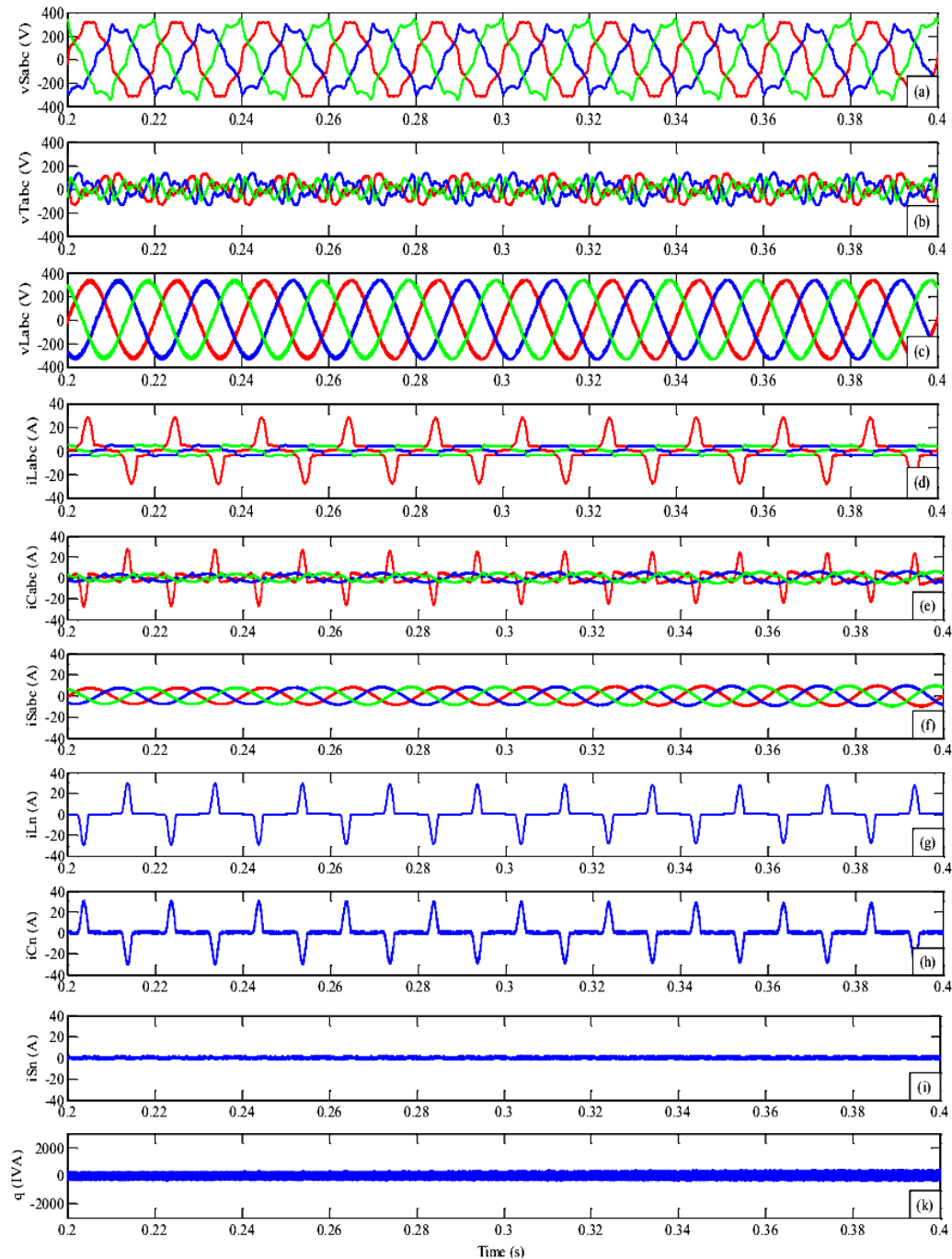

Fig. 8. Simulation results for conventional p - q method: (a) distortional unbalanced voltages of the source (b) voltages injected by the transformer (c) load voltages (d) unbalanced and nonlinear load currents (e) currents injected by the compensator (f) source currents (g) load neutral current (h) neutral current injected by compensator (i) source neutral current (h) instantaneous reactive power.

besides compensating load unbalance, supplying reactive power and compensating harmonics, the UPQC controller gets a new static state after the load change. Furthermore, Fig. 7 (i) shows that a slight change in dc-link voltage oc-

curs at the moment that the load change (0.2s) which is immediately controlled by the dc-link voltage controller and the dc-link voltage returns to its previous value.

5 COMPARISON TO THE CONVENTIONAL APPROACHES

Conventional techniques published so far in the literature have more computational burden and also most of them use PLL which makes these techniques more complicated. The proposed method is a simple approach for effectively current and voltage harmonics compensation, reactive power and load balancing. Other advantages of this approach is the reduction of number of current and voltage measurements for controlling the shunt and series APFs. In the proposed method, to control the shunt APF we just need to measure the source current whereas in conventional techniques it is necessary to measure the currents of load, source and shunt APF. In the proposed control method it is not necessary to measure neither the current of shunt APFs or voltages of series APFs which have fast variations and cause computational delay. In order to compare the proposed approach with conventional p-q method, the results obtained from both these techniques are compared in Table 2. The simulation results obtained by using conventional p-q method are shown in Fig. 8. Fig. 8 (a) shows the source harmonic voltages before compensation. It could be seen from Fig. 8 (c) that by injecting compensating voltages into system, the series APF creates sinusoidal load voltages and decreases the load voltage THD from 11.16% to 2.23% whereas in proposed control method, the load voltage THD is decreased from 11.16% to 1.52%. The voltages injected by the series APF are shown in Fig. 8 (b). On the other hand, Fig. 8 (f) shows that, by injecting compensating currents into network, the shunt APF compensates load unbalance and load current harmonics and decreases the source current THD from 28.72% to 3.04% whereas in proposed control method source current THD is decreased from 28.72% to 2.37%.

The unbalanced distorted load currents and shunt APF injected currents are shown in Fig. 8 (d) and Fig. 8 (e) respectively. The source neutral current is decreased to zero by the shunt APF as shown in Fig. 8 (i). It could be seen from Fig. 8 (k) that reactive power is fully compensated by shunt APF. Simulation results show that the proposed control technique outperforms the conventional p-q control method.

Table 2. THD of the supply currents and load voltages

| Supply currents/load Voltage | Without UPQC | UPQC with proposed method | UPQC With conventional p-q method |
|------------------------------|--------------|---------------------------|-----------------------------------|
| %THD in current in Phase "a" | 28.72% | 2.37% | 3.04% |
| %THD in load Voltage | 11.16% | 1.52% | 2.23% |

6 CONCLUSION

In this paper, the performance of the proposed control method for a three-phase four wire UPQC was investigated. Simulation results show the capability of proposed control approach in dealing with the power quality problems such as load balancing, load reactive power compensation, and current and voltage harmonics compensation under voltage unbalance conditions. In the proposed control method, to control the shunt APF we just need to measure source current while in conventional methods currents of load, source and shunt APF must be measured. Therefore, the number of current measurements is decreased in proposed approach. Simulation results show that under conditions of unbalanced and nonlinear load current, this method not only decreases the effects of unbalance distorted load in the power system, but also improves the power factor. Meanwhile, whenever the source voltages are distortional and unbalanced, the series APF provides sinusoidal voltages for loads. Also, in this research it is shown that the UPQC simultaneously compensates voltage and current problems and it has the best compensation features even during the emergence of unbalanced components in the three-phase four-wire electrical systems. Simulation results reveal that the proposed control technique with STF has better compensation performance than conventional p-q control theory.

REFERENCES

- [1] E. Gunther, "Mehta H. A survey of distribution system power quality," *IEEE Transaction on Power Delivery*, vol. 10, pp. 322-329, 1999.
- [2] L. Geun-Joon; M. Albu, G. Heydt, "A power quality index based on equipment sensitivity, cost, and network vulnerability," *IEEE Transaction on Power Delivery*, vol. 19, pp. 1504-1510, 2004.
- [3] E. Fuchs, M. A.S. Mausoum, "Power Quality in Power Systems and Electrical Machines," London, Elsevier, UK: Academic Press, 2008.
- [4] B. Singh, A. Haddad, A. Chandra, "A review of active filters for power quality improvement," *IEEE Transactions on Industrial Electronic*, vol. 46, pp. 960-971, 1999.
- [5] H. Akagi, "New trends in active Filters for power conditioning," *IEEE Transactions on Industry Applications*, vol. 32, pp. 1312-1322, 1996.
- [6] H. Akagi, A. Nabae, "A new approach to harmonic compensation in power systems-a combined system of shunt passive and series active filters," *IEEE Transactions on Industry Applications*, vol. 26, pp. 983-990, 1990.
- [7] H. Fujita, H. Akagi, "The unified power quality conditioner: the integration of series- and shunt active filters," *IEEE Transaction on Power Electronics*, vol. 13, pp. 315-322, 1998.

- [8] K. Sen, E. Stacey, "UPFC-unified power flow controller: theory, modeling, and applications," *IEEE Transaction on Power Delivery*, vol. 13, pp. 1453-1460, 1998
- [9] B. Han, B. Bae, H. Kim, S. Baek, "Combined operation of unified power-quality conditioner with distributed generation," *IEEE Transaction on Power Delivery*, vol. 21, pp. 330-338, 2006.
- [10] T. Zhili, L. Xun, C. Jian, K. Yong, D. Shanxu, "A direct control strategy for UPQC in three-phase four-wire system," *IEEE Transaction on Power Electronics and Motion Control*, vol. 2, pp. 1-5, 2006.
- [11] V. Khadkikar, A. Chandra, "A novel structure for three-phase four-wire distribution system utilizing unified power quality conditioner (UPQC)," *IEEE Transaction on Industry Applications*, vol. 45, pp. 1897-1902, 2009.
- [12] L. Xun, Z. Guorong, D. Shanxu, C. Jian Chen, "Control Scheme for Three-Phase Four-Wire UPQC in a Three-Phase Stationary Frame," *IEEE 33rd Annual Conference of the Industrial Electronics Society*, pp. 1732-1736, 2007.
- [13] A. Ghosh, A. Jindal, A. Joshi, "A unified power quality conditioner for voltage regulation of critical load bus," *IEEE Power Energy Society General Meeting*, vol. 1, pp. 471-476, 2004.
- [14] G. Bhuvaneswari, D. M. Nair, "Simulation and analog Circuit Implementation of a Three-Phase Shunt Active Filter Using the ICos Φ Algorithm," *IEEE Transaction on Power Delivery*, vol. 23, pp. 1222-1235, 2008.
- [15] P. Yash, A. Swarup, B. Singh, "A Novel Control Strategy of Three-phase, Four-wire UPQC for Power Quality Improvement," *Journal of Electrical Engineering & Technology*, vol. 7, pp. 1-8, 2012.
- [16] A. Teke, L. Saribulut, M. Tumay, "A Novel Reference Signal Generation Method for Power-Quality Improvement of Unified Power-Quality Conditioner," *IEEE Transactions on Power Delivery*, vol. 26, pp. 2205-2214, 2011.
- [17] M. H. Abardeh, R. Ghazi, "A new reference waveform estimation strategy for unified power quality conditioner (UPQC)," *IEEE International Energy Conference and Exhibition*, pp. 704-709, 2010.
- [18] G. Chen, Y. Chen, K. Smedley, "Three-phase four-leg active power quality conditioner without references calculation," *IEEE Applied Power Electronics Conference and Exposition*, pp. 587-593, 2004.
- [19] M. Kesler, E. Ozdemir, "Synchronous-Reference-Frame-Based Control Method for UPQC Under Unbalanced and Distorted Load Conditions," *IEEE Transactions on Industrial Electronics*, vol. 58, pp. 3967-3975, 2011.
- [20] A. J. Viji, M. Sudhakaran, "Generalized UPQC system with an improved control method under distorted and unbalanced load conditions," *International Conference on Computing, Electronics and Electrical Technologies*, pp. 193-197, 2012.
- [21] C. H. Da Silva, R. R. Pereira, L. E. B. Da Silva, G. Lambert-Torres, A. B. K. Bose, "Digital PLL Scheme for Three-Phase System Using Modified Synchronous Reference Frame," *IEEE Transactions on Industrial Electronics*, vol. 57, pp. 3814-3821, 2010.
- [22] J. M. Correa, F. A. Farret, M. G. Simoes, "Application of a Modified Single-Phase P-Q Theory in the Control of Shunt and Series Active Filters in a 400 Hz Microgrid," *36th IEEE Power Electronics Specialists Conference*, pp. 2585-2591, 2005.
- [23] S.A.O, Da Silva, R. Barriviera, R. A. Modesto, M. Kaster, A. Goedtel, "Single-phase Power Quality Conditioners with series-parallel filtering capabilities," *IEEE International Symposium on Industrial Electronics*, pp. 1124-1130, 2011.
- [24] A. J. Viji, M. Sudhakaran, "Flexible 3P4W system using UPQC with combination of SRF and P-Q theory based control strategy," *22nd Australasian Universities Power Engineering Conference*, pp. 1-5, 2012.
- [25] M. Kesler, E. Ozdemir, "A novel control method for unified power quality conditioner (UPQC) under non-ideal mains voltage and unbalanced load conditions," *25th Annual IEEE Applied Power Electronics Conference and Exposition*, pp. 374-379, 2010.
- [26] K. Kwan, Y. Chu, P. So, "Model-based H ∞ control of an unified power quality conditioner," *IEEE Transaction on Industrial Electronics*, vol. 56, pp. 2493-2504, 2009.
- [27] A. Teke, L. Saribulut, M. Tumay, "A Novel Reference Signal Generation Method for Power-Quality Improvement of Unified Power-Quality Conditioner," *IEEE Transaction on Power Delivery*, vol. 26, pp. 2205-2214, 2007.
- [28] S. Bhattacharya, T. Frank, D. Divan, B. Banerjee, "Active filter system implementation," *IEEE Industry Applications Magazine* vol. 4, pp. 47-63, 1998.
- [29] B. Han, B. Bae, S. Baek, G. Jang, "New configuration of UPQC for medium-voltage application," *IEEE Transaction on Power Delivery*, Vol. 21, pp. 1438-1444, 2006.
- [30] A. Ghosh, G. Ledwich, "A unified power quality conditioner (UPQC) for simultaneous voltage and current compensation," *Electric Power Systems Research*, vol. 59, pp. 55-63, 2001.
- [31] H. Akagi, E. Watanabe, M. Aredes, "Instantaneous power theory and applications to power conditioning," New Jersey, John Wiley & Sons, 2007.
- [32] H. Song, H. Park, K. Nam, "An instantaneous phase angle detection algorithm under unbalanced line voltage condition," *30th Annual IEEE Power Electronics Specialists Conference*, pp. 533-537, 1999.
- [33] M. Abdusalam, P. Poure, S. Karimi, S. Saadate, "New digital reference current generation for shunt active power filter under distorted voltage conditions," *Electric Power Systems Research* vol. 79, pp. 759-765, 2009.
- [34] P. Melin, J. Espinoza, L. Moran, J. Rodriguez, V. Cardenas, C. Baier, J. Munoz, "Analysis, Design and Control of a Unified Power Quality Conditioner Based on a Current-Source Topology," *IEEE Transaction on Power Delivery*, vol. 27, pp. 1727-1736, 2012.



Mahmoud Ebadian received his B.Sc. in electrical engineering from Mashhad Ferdowsi University, Mashhad, Iran, in 1991, his M.Sc. from Kh. N. Toosi University of Technology, Tehran, Iran, in 1996, and his Ph.D. from Moscow Power engineering Institute, Moscow, Russian Federation in 2006. His areas of interest include: voltage collapse, voltage stability, microgrid control, power quality studies and FACTS devices. His is

an associate professor at Department of power Engineering, University of Birjand, south khorasan, Iran.



Mohammad Talebi was born in Ardakan, Iran on 1988. He received BSc degree in electrical engineering from Islamic Azad University, Yazd Branch, Iran, in 2010, his M.Sc from University of Birjand, Birjand, Iran, in 2013. His research interests are reactive power control in transmission & distribution systems, power quality studies and FACTS devices.



Reza Ghanizadeh was born in Mianeh, Iran on 1987. He received Associated degree in electrical engineering from Tabriz College of Technology 2007, his B.Sc. degree in electrical engineering from Islamic Azad University, Ardabil Branch, Iran, in 2009, his M.Sc from University of Birjand, Birjand, Iran, in 2012. He is currently a Ph.D student at department of power engineering, University of Birjand, Birjand, Iran. His research

interests are power system stability, reactive power control in transmission & distribution systems, microgrid control, power quality studies and FACTS devices.

AUTHORS' ADDRESSES

Assoc. Prof. Mahmoud Ebadian, Ph.D.

Mohammad Talebi, MSc.

Reza Ghanizadeh, student

Faculty of Electrical and Computer Engineering,

University of Birjand,

Birjand, Iran

email: mebadian@birjand.ac.ir,

mohammad.talebi@birjand.ac.ir, r_

ghanizadeh@birjand.ac.ir

Received: 2014-01-26

Accepted: 2014-06-05