

Empirical Analysis of a Self-service Check-in Implementation in Singapore Changi Airport

Regular Paper

CKM Lee^{1,*}, Yuankei Ng², Yaoqiong Lv² and Park Taezoon³

1 Department of Industrial and Systems Engineering, The Hong Kong Polytechnic University, Hong Kong

2 Division of Systems and Engineering Management, School of Mechanical and Aerospace Engineering, Nanyang Technological University

3 Department of Industrial Information Systems Engineering, College of Engineering, Soongsil University

* Corresponding author E-mail: ckm.lee@polyu.edu.hk

Received 1 July 2013; Accepted 1 September 2013

DOI: 10.5772/56962

© 2014 The Author(s). Licensee InTech. This is an open access article distributed under the terms of the Creative Commons Attribution License (<http://creativecommons.org/licenses/by/3.0>), which permits unrestricted use, distribution, and reproduction in any medium, provided the original work is properly cited.

Abstract The purpose of this paper is to provide an empirical analysis an airport passenger operation and to improve its efficiency. An investigation was conducted to evaluate the quantitative and qualitative efficiency of the self-service check-in booth in Singapore Changi Airport. Through Arena simulation software, this investigation gives an estimation of how much processing time and queuing time the self-service check-in booths have been reduced, providing a quantitative analysis of the self-service check-in booth. A modified technology acceptance model featuring a prediction of how well passengers accept this new concept has also been used in this investigation. The results show that the self-service check-in booth's operation is generally efficient based on quantitative and qualitative analysis, providing a recommendable service to customers.

Keywords Self-Service Check-In, Technology Acceptance Model, Airport operations, Simulation

1. Introduction

Singapore Changi International Airport handled a total of 37.7 million passengers and 1.857 million tons of cargo in 2008 [1]. The airport industry has been growing ever since globalization took place. Air traffic is at its busiest of all time, as there is an upward demand for air travel coupled with new airports multiplying themselves rapidly over the world. Within a timeframe of less than three decades, Singapore Changi Airport has developed into a global leader in the airport industry. This is because of its constant improvements in its operating procedures and constant upgrading of its facilities, so as to keep up with the ever-changing consumer demand and trends, and to maintain their position as the top in the industry. Singapore Changi Airport has shown the results of its success by winning more than 280 international awards since its opening in 1981, and was named in the World's Best Airport Awards in 2010 [2]. Hence, Singapore Changi Airport is a perfect benchmark model in studying its operation and conduct for further research and improvement.

There are many factors contributing to the success of an airport. The passengers processing operation is a major factor. It affects the satisfaction of passengers significantly. A passenger processing operation consists of checking-in a passenger and their baggage into the aircraft. It is vital for airports to provide ease and convenience in terms of checking-in. The time taken for passengers to process their check-in is important, since passengers do not want to waste their time standing in line waiting for their turn to check-in. Hence, airport management often pay much attention to ensuring that the flow of the entire process is efficient and smooth. Many new methods of checking-in have been introduced in recent years, such as online check-in (OCI) systems and short messaging services check-in (SMSCI) systems as opposed to traditional check-in (TCI) over the counter. The most recent method of checking-in will be seen by the increasing popularity of self-service check-in (SSCI) booths at the terminal itself.

SSCI booths provide passengers at the terminal with another alternative for checking-in. It provides the same services as at the check-in counter. Passengers have to scan their issued e-ticket and key-in their personal information. Afterwards, they may proceed to select their preferred seats and then go on to the queue in order to check-in their baggage. Ever since the introduction of SSCI booths, queues at the traditional check-in counters have been significantly minimized. Traditional ideas, spanning decades, are quickly becoming a thing of the past; nowadays, passengers no longer need to queue to a check-in counter before boarding the aircraft. In the short span of five years, the SSCI concept has gone from a sketchbook idea into an operation enhancement, providing seamless travel globally.

The Civil Aviation Authority of Singapore (CAAS) issued a news release detailing increasing the number of self-check-in booths in all three terminals in Changi Airport in 2008 [3]. A survey conducted by SITA, a specialist provider of IT solutions to airlines and airports, has revealed evidence from passengers surveyed at six of the world's busiest airports across five continents, that self-service is fast becoming the norm for passengers from Atlanta to Moscow. The findings from the survey confirmed that self-service is here to stay, with the potential for truly explosive growth in emerging markets. Despite low internet penetration in India, for example, already almost 20% of passengers at the country's largest airport - Mumbai International - are using the web to check-in [4]. Overall, 57.6% of surveyed passengers are now using use the web to book their flights and 36% employ the self-check-in system online or at an SSCI booth, and the probability of the repeat usage of such services seems to be high. One-stop SSCI booths are already available in some countries. Passengers only have

to go to a single booth to obtain the boarding pass, and tag and check-in their own luggage at a fully-automated booth. An example of such a facility is the one-stop SSCI booth at Dubai International Airport.

This paper carries out an investigation of the efficiency of the SSCI booths in Singapore Changi Airport. The efficiency of the SSCI booths has two determinants. The first determinant is how many quantitative benefits it provides to enhance the entirety of the operation and the experiences of passengers. The second determinant is the acceptance level of the SSCI booths. Using an analysis model and simulation software, this paper attempts to provide an all-rounded analysis of its efficiency. A quantitative and a qualitative level of efficiency will be reviewed through the investigation.

2. Literature Review

As this research is based on investigating the efficiency of SSCI booths in terms of quantitative and qualitative approaches, a literature survey is conducted to search for theories or models that might aid us in our investigation.

There is one method for investigate efficiency quantitatively based on a simulation model. By simulation, with the aid of a set of real data, it is possible to generate multiple replications of random scenarios that are close to the parameter set from the data collected empirically. A simplified version of the model development process and its validation is shown in Figure 1 [5].

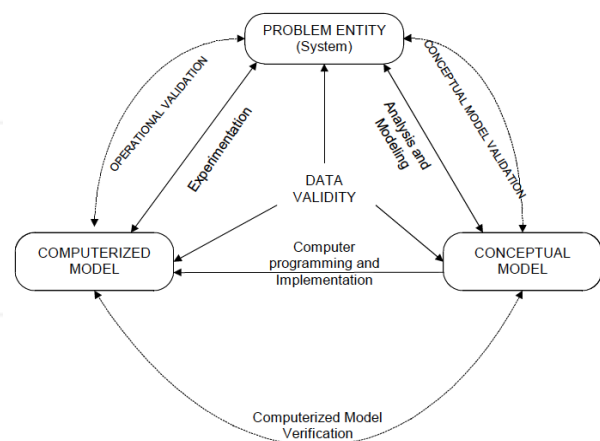

Figure 1. Model Development and Validation Process

Since the airport is exposed to air traffic developments and external influences, it is desirable to validate and repeat the study results frequently. One of the greatest advantages of using simulation software in airports is that once you have developed a valid simulation model, operating procedures or methods can be altered and tested without the expense and disruption of experimenting with the real system. Modifications are

incorporated into the model and one can observe the effects of those changes on the computer rather than on the real system. It is also possible to test the SSCI concept with numerous variables, like the number of queuing passengers and the number of TCI counters opened for check-in using simulation.

In terms of qualitative analysis, there are a couple of methods used to test the hypotheses made to verify the efficiency of the SSCI concept. One of these is by using the critical incident technique (CIT) to explore the factors affecting passengers' satisfaction and dissatisfaction in engaging with the SSCI concept. The CIT is a set of procedures for gathering and analysing reports of incidents and behaviours observed first hand that involve "certain important facts concerning behaviour in defined situations" [6]. The CIT analysis was introduced by Flanagan (1954) [6] in the Aviation Psychology Programme of the US Air Force. Initially, its primary use was to aid in personnel selection and the identification of pilot errors. In recent years, CIT analysis has been employed in numerous ways, including: service management [7], self-service technologies [8] and social sciences. However, using this CIT and employing it to compute the results is to rely on tedious statistical analysis.

Another method of measuring qualitative efficiency, the technology acceptance model (TAM), is more appropriate for this problem. TAM was proposed by Davis et al. in 1989 [9], and has been one of the most widely-applied individual-level technology adoption models, [10], [11], [12], [13], [14]. Even though several alternative models of technology adoption have been proposed and successfully validated, such as Ajzen's (1991) theory [15] of planned behaviour (TPB) and Moore and Benbasat's (1991) [16] perceived characteristics of innovating (PCI), TAM is still employed frequently because of its parsimony and robustness [12]. Additionally, and according to two qualitative meta-analyses done by Legris et al. (2003) [11] and Schepers and Wetzels (2007) [13], TAM is a useful model. Conversely, Plouffe et al. (2001) [12] have pointed out that although the characteristic of parsimony in TAM is an important consideration, perceptions of individuals faced with new technologies are likely to differ depending on the context within which they are encountered. A complete understanding of the acceptance behaviour across different contexts is necessary as well. Thus, TAM is only a basic model, and we should consider the additional factors that capture the richness of the process of new technology adoption by passengers.

TAM is primarily built from the theory of reasoned action proposed by Fishbein and Ajzen in 1975 [17], [11], [12], [13], [14]. TAM explains technology usage as the goal of a four-stage process, as shown in Figure 2.

- a) External variables influence users' beliefs in using a given system.
- b) The users' beliefs influence their attitudes in using that system.
- c) The users' attitudes influence their intentions to use a system.
- d) The users' intentions determine the level of usage of the system.

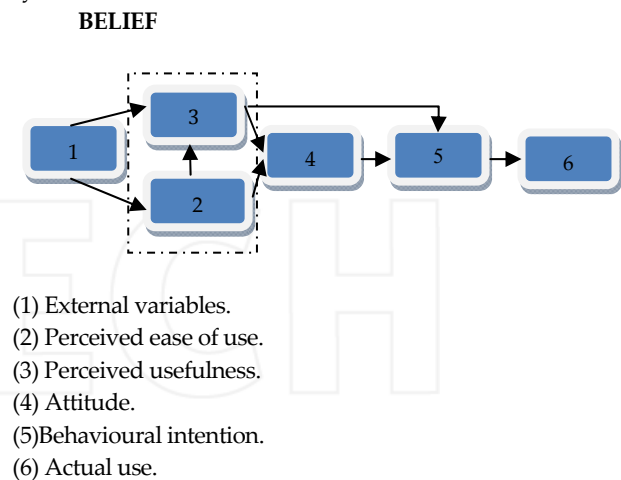

Figure 2. TAM Model – Four Stages Process

TAM has been applied in many studies and has mostly achieved good results, although several stronger model studies have suggested that TAM still needs additional variables to modify it into an event, [11], [18], [19]. The definitions of external variables, in particular, might vary by individual differences. In Davis et al.'s paper (1989) [9], which was the paper originally formulating TAM, the external variables were defined as the constructs, namely computer self-efficacy, objective usability, and direct experience. Nevertheless, Jackson et al. (1997) [20] defined the external variables as consisting of situational involvement, intrinsic involvement, prior use and argument for change. In Karahanna et al.'s paper (1999) [21], however, the external variables included compatibility, trainability, visibility and result demonstrability.

Therefore, TAM appears to be a concise model formed as a base model in this investigation. In this project, appropriate variables - which are deemed unique to our case study - shall be incorporated into TAM. Hypotheses based on the modified TAM will then be tested through a series of interviews and surveys.

3. Modelling for the Passenger Processing Operation

The term 'passenger processing' actually means the administrative work that the airline has to go through with the passenger before they board the plane. The passenger will have to provide evidence of booking the flight and the necessary documents. The airline ground

crew will then confirm the passenger information and allocate a seat on the aircraft to the passenger. The passenger will subsequently check-in his baggage and proceed to the gate. This repetitive procedure is typical in every airport around the world. The only difference concerns how efficient it is. There are airports with extremely inefficient check-in counters, which resulted in passengers standing in a queue for more than 30 minutes. There are also airports with insufficient counters to cater for the number of passengers, not forgetting airports with inconvenient baggage check-in systems. It is important for the airport management to ensure that check-in is fast and hassle-free. In order to be efficient, there must be sufficient number of counters with staff who are motivated and customer-orientated, as well as with various check-in alternatives to minimize the queue at the counters.

The self-check-in booth is one of the latest features in most developed airports around the world. Different airports/airlines use different interfaces or software in their SSCI booths. An efficient self-check-in booth is easy to use and takes minimal time. An efficient booth completes the following processes: (1) request the passenger flight number; (2) confirm the passenger particulars; (3) allow the passenger to select an available seat; (4) issue a boarding pass; (5) weigh the baggage; (6) issue the baggage check-in tag; (7) accept the baggage.

However, there are not many airports providing processes five through to seven. Self-check-in baggage remain a very new feature, and is not yet commonly used around the world. One example of a successful implementation of an efficient self-check-in booth is Dubai International Airport Terminal 3. A passenger can obtain his boarding pass and check-in his baggage in less than two minutes.

In Singapore Changi Airport, the self-check-in is limited to the issuing of a boarding pass. A separate lane is available to provide additional convenience for self-check-in users to check-in their baggage. Thus, it promotes passengers to self-check-in and reduce the number of passengers joining the queue at the counters. It is also cheaper in the long-run to operate more self-check-in booths than a typical manned counter.

Every airport has a standard layout. In figure 3 can be seen a flow of how passengers proceed from one point to another and, ultimately, to the aircraft.

As shown in figure 3, passengers transit from the land-side to the air-side of the terminal through two major parts of the terminal. The most interactive component of the terminal is the general concourse and the gate lounge. Firstly, the gate lounge is where passengers spend most

of their time after they clear customs and immigration. Usually, passengers have their needs and wants satisfied here before they board the plane. There are duty free stores, cafeterias and Internet kiosks, etc. The focus of this section will be at the general concourse, where the passenger processing takes place.

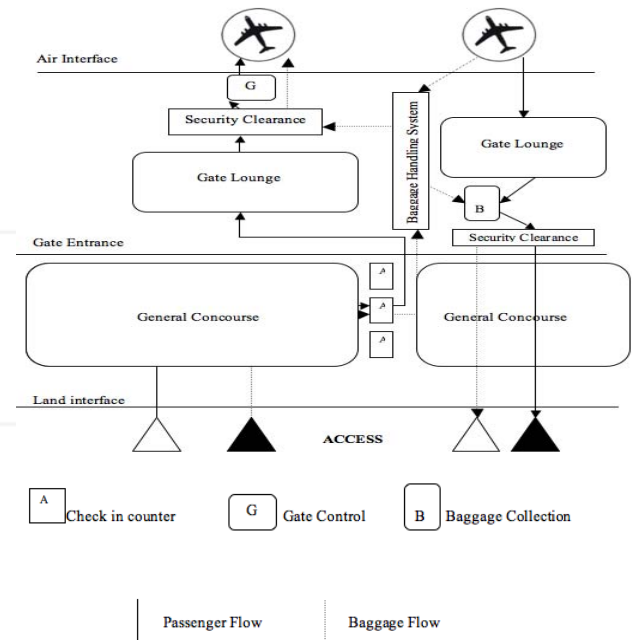

Figure 3. Passenger and Baggage Flow System

At the general concourse, there are facilities to cater to the passengers' needs. Passengers are held at this area before their boarding time. Similar to the gate lounge, it has all the facilities to cater to passengers' needs. However, before passengers get to enjoy the facilities in the terminal, they have to first check-in at the counters. Hence, it is vital to minimize the time spent on checking-in. In figure 4, the flow of the passenger can be seen in relation to the layout of the Changi Airport Terminal 3. Additionally, figure 5 gives out the belt layout.

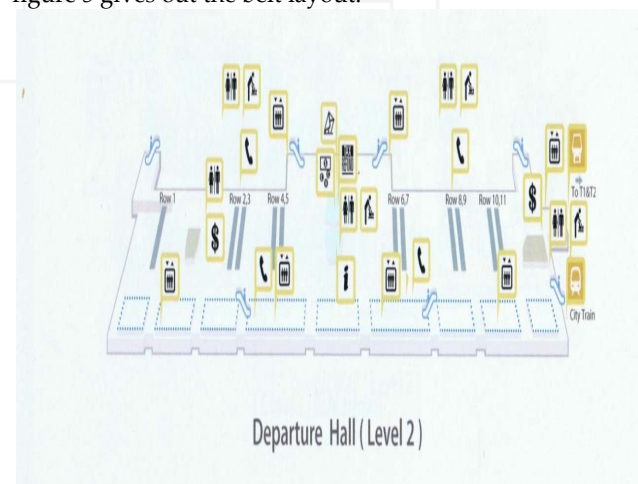

Figure 4. Passenger Flow in relation to the Layout of Changi Airport Terminal 3

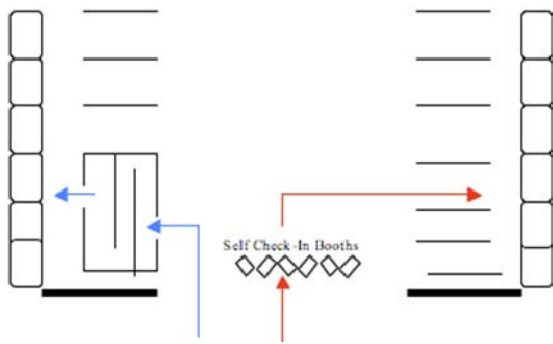

Figure 5. Belt Layout

Figure 5 shows a layout of a belt in Terminal 3. The check-in belt is the first place that the passenger will go to when he reaches a terminal for check-in purposes. At the belt, he will get his boarding pass and also check-in his baggage. After checking-in, the passenger may then proceed to the gate.

In Figure 5, there are two different sets of arrows. The blue arrows indicate a typical queue to check-in over the counter. The red arrows indicate the path that a self-check-in passenger will take at the belt. In Singapore Changi Airport Terminal 3, and along the Singapore Airlines belts, Figure 5 shows the two options of checking-in available to passengers. Typically, there are more passengers in the queue over the counter while the queue for SSCI booths is significantly smaller.

4. Quantitative and Qualitative Analyses for SSCI Booths' Implementation

4.1 Quantitative Analysis through a Simulation Based On Empirical Observation

In this section, a quantitative method will be used for the analysis of both those belts with SSCI booths and those without them to show the superiority of the passenger processing operation following the SSCI booths' implementation.

As mentioned earlier, this study focuses on Singapore Changi Airport and empirical observations are made of two selected passenger processing operations: a) Singapore Airlines SQ352, SIN-CPG 10, March 2009, 0105hrs; b) Qantas Airlines QF319, SIN-CPG, 10 March 2009, 2329hrs.

The decision to select these two flights for our analysis lies in the fact that they both fly to the same destination, they both depart at around midnight, they both operate on a Boeing 777-200 and, most importantly, Singapore

Airlines' belts are equipped with six SSCI booths while Qantas Airlines only operates traditional check-in booths. Therefore, by selecting these two flights, we are setting the conditions of the two scenarios to be as similar as possible. A control analysis on the efficiency of the SSCI booths can then be performed.

Before performing any analysis, criteria for measurement have to be set. These criteria must be met in order to prove that SSCI booths improve the efficiency of the passenger processing operation. Table 1 gives a list of criteria that will prove the improvement in efficiency. The table shows the three criteria that need to be met in order to prove that the SSCI booths are actually improving the efficiency of the operation in question. These criteria bring benefits to airport operators as well as satisfaction to passengers.

Criteria proving an improvement in efficiency	
1.	The number of passengers processed increased
2.	The average processing time (APT) of a passenger is reduced
3.	The average queue time (AQT) of a passenger is reduced

Table 1. Criteria Proving an Improvement in Efficiency

The quantitative analysis of the operation is done in two parts. First, by empirical observation, a set of real data from the actual operation at the terminals is recorded. This set of data consists of the different times taken at the different parts of the operation process. With this set of data, a good approximation can be retrieved and used in the second part of the quantitative analysis. In that part, a simulation of the passenger processing operation of the selected flights will be carried out in 10 repetitions. From this simulation, a set of results predicting what can happen in reality is obtained. By comparing the results between the selected flights and matching it to the criteria set earlier, it is possible to determine the improvement of the efficiency of the operation.

4.1.1 Data Collected from Empirical Observation

The data are collected through empirical observation, counting and time keeping.

In table 2, the results of an empirical observation on the belts of Singapore Airlines in Changi Airport Terminal 3 are shown.

This data is collected by empirical observation and helps us to validate the criteria for proving the improvement that is brought about by the use of SSCI booths.

Observation at Singapore Airlines' belts in Changi Airport Terminal 3	
Number of passengers processed:	
Total number of passengers processed at the traditional check-in counters	138
Total number of passengers processed at the SSCI booths	34
Total number of passengers processed at the belts	172
Time taken to process a passenger over a traditional counter: (n=60) (six counters)	
Maximum amount of time taken (min)	9
Minimum amount of time taken (min)	4
Average amount of time taken (min)	7
Time taken to process a passenger at the SSCI booth: (n=20)	
Maximum amount of time taken (min)	4
Minimum amount of time taken (min)	2
Average amount of time taken (min)	3
Time taken to process a passenger at the baggage check-in counter: (n=20)	
Maximum amount of time taken (min)	5
Minimum amount of time taken (min)	2
Average amount of time taken (min)	3

Table 2. Data Collected by Empirical Analysis of Singapore Airlines' Operation

Observation at Qantas Airlines' belts in Changi Airport Terminal 1	
Number of passengers processed:	
Total number of passengers processed at the traditional check-in counters	148
Time taken to process a passenger over a traditional counter: (n=60) (seven counters)	
Maximum amount of time taken (min)	8
Minimum amount of time taken (min)	4
Average amount of time taken (min)	6

Table 3. Data Collected by Empirical Analysis of Qantas Airlines' Operation

The analysis of the two collected data sets will be further discussed in the second part of this section.

4.1.2 Data Collected from the ARENA Simulation Software

After collecting the data from the empirical observations, as shown in the earlier part, this data will be used in facilitating the simulation process for quantitative analysis. The software that we chose to perform this simulation was ARENA Simulation, by Rockwell Automation. Setting this data into flow logic in the Arena Simulation software, the operation process of the flight can be repeated and more statistical results can be broken down and derived. Adjustments are made to the logic and compared to the real data again so as to validate the conceptualized model. Only after the appropriate adjustments have been made can the model be used to simulate the desirable scenario and obtain the results to be tested. In figure 6, a flowchart of Singapore Airlines' passenger processing operation is shown.

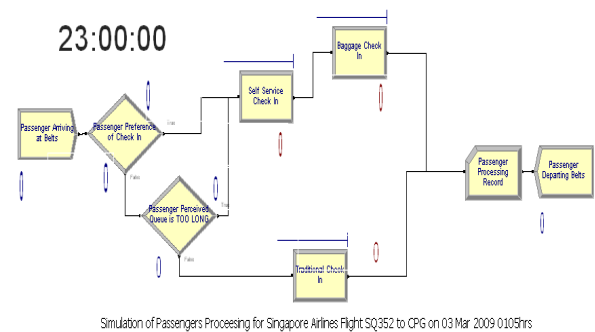

Figure 6. Flowchart of Singapore Airlines' Passenger Processing Operation

The flowchart shows the entire procedure from the moment that the passengers arrive at the airport terminal, to proceeding to the respective belts for check-in. At the belt, passengers will decide whether to use the SSCI booths or else to move to the TCI counter. From our data collected in the earlier part of this section, 24.6% of users chose to use the SSCI booths while the remaining 75.4% of the passengers would proceed to another decision module. At such a decision module, the passengers would judge the situation at the TCI counters and make a decision as to whether to join the queue at the TCI counters or proceed to the SSCI booths. If the queue was too long - which is when more than half of the ground area is taken up in the queue (viz., more than 20 people in the queue will contribute to this situation) - passengers will choose to use the SSCI booths to avoid having to join the long queue.

At the SSCI booths, passengers took an average of three minutes to complete the check-in process before proceeding to the baggage check-in counter. At the baggage check-in counter, passengers spent an average of three minutes at the counter. On the other hand, a passenger spent on average about six minutes at the TCI counters. After checking-in at either the booths or the

counters, the passengers would leave the belts. With the inputs of all the data collected, the simulation could be processed, and figure 7 displays an image of the final outcome of the simulation.

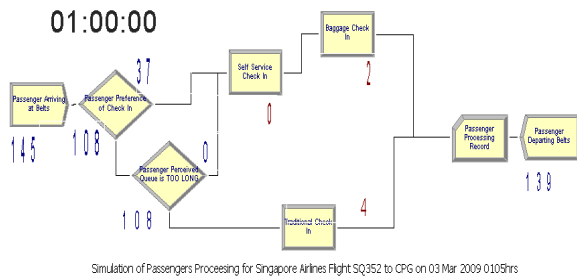

Figure 7. Outcome of a Simulation of Singapore Airlines' Passenger Processing Operation

As the time of the flight is at 01.05 hrs, typically the bulk of passengers arrive one or two hours before the scheduled flight time. Hence, the simulation is set to start from 23.00 hrs to 01.00 hrs; a total of two hours of actual time is simulated. Within these two hours, 145 passengers arrived at the terminal. 108 of them proceeded to TCI counters and 37 of them proceeded to the SSCI booths. Even though the simulation was terminated after two hours, passengers were still queuing up at both the baggage counters and the TCI counters. Finally, a total of 139 passengers were processed within the duration of two hours.

Figure 8 shows a flowchart of Qantas Airlines' passenger processing operation. The figure clearly shows that there are no SSCI booths in the passengers processing operation. They only operate on the TCI counters.

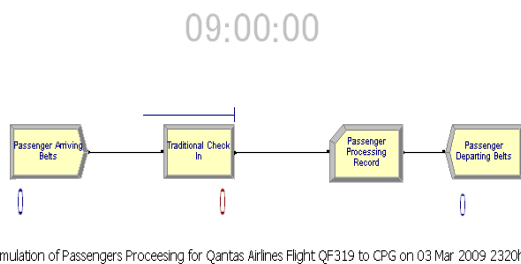

Figure 8. Flowchart of Qantas Airlines' Passenger Processing Operation

Similarly, the simulation is set to be approximately two hours before flight time. The flow is also similar to the Singapore Airlines flow, the only difference being the lack of SSCI booths. Figure 9 shows an outcome of a simulated process.

For the same duration of two hours, Qantas Airlines' passenger processing operation received 164 passengers and had 135 passengers processed, with 29 more passengers in a queue over the TCI counters.

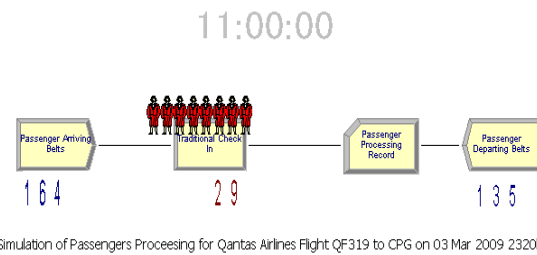

Figure 9. Outcome of a Simulation of Qantas Airlines' Passenger Processing Operation

The simulation of both operations will be done repetitively, 10 times. This is to obtain statistically averaged-out results, which are better for basing our analysis upon. Through a series of simulations, a set of results is obtained:

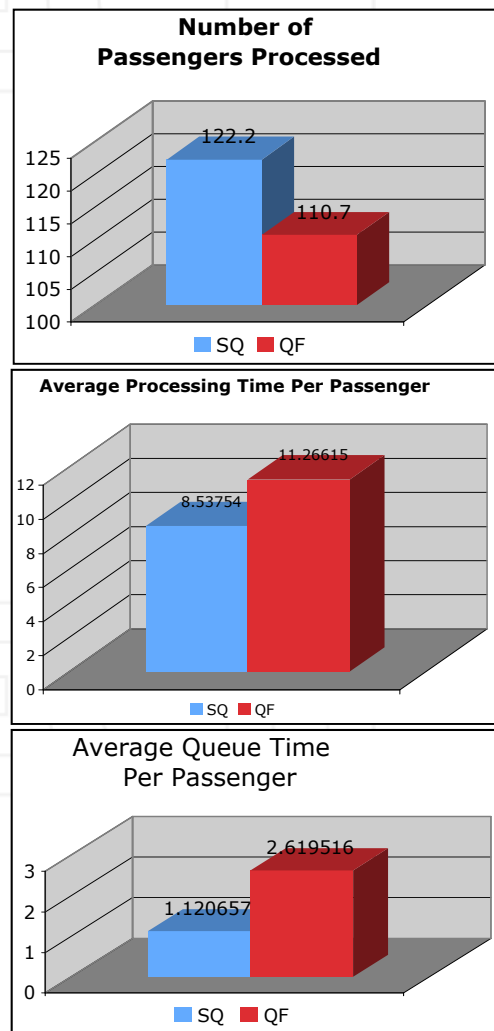

Figure 10. Comparison between the two Airlines (number of passengers processed in two hours, APT and AQT)

From figure 10, it can be seen that SQ (operating with SSCI booths) has a higher total number of passengers processed in two hours than QF. It can also be seen that

operating with SSCI booths can process 9.4% more passengers than operating without SSCI booths. Moreover, SQ has a lower APT of 8.53754 minutes than QF, which has an APT of 11.26615 minutes. This means that SQ is able to process passengers faster than QF and that SQ has a 31.9% advantage in terms of APT.

What is more, it is true that SQ has a lower AQT than QF. SQ, with an AQT of 1.120657 minutes, is 133.7% superior to QF. This shows that a passenger checking-in with SQ spends less time in the queue than a passenger checking-in with QF. Once again, this proves the superiority and efficiency of operating with SSCI booths.

The passenger processing operation with SSCI booths is proven to have a higher efficiency than just operating with TCI counters. With these SSCI booths at the terminal, it also gives passengers another alternative to checking-in for a flight. Increasing the options to check-in increases the convenience for passengers. Furthermore, when the queue is long, passengers have another option to check-in rather than joining such a long. Secondly, it increases the capacity of the operation. For a given amount of time, the operation is able to process more passengers because there are both TCI counters and SSCI booths. This could lead to a saving in operation costs. SSCI booths ease the load on TCI counters. Hence, it is possible to reduce the number of TCI counters if the SSCI booths are frequently used. Thirdly, the APT is reduced. This means that the operation is more efficiency, as it takes a shorter time to process a passenger. The passenger benefits from a lower APT too. When the APT is low, the passenger spends less time checking-in. Now, the passenger can spend his time enjoying the amenities or other facilities in the terminal. Lastly, with SSCI booths, passengers spend less time in the queue. AQT is reduced, which further supports the reason given above. In conclusion, SSCI booths are proven to be an enhancement to passenger processing operations and they deliver benefits to both airport operators and passengers as well.

4.2 Qualitative Analysis through a Modified Technology Acceptance Model

In this section, a qualitative method is presented to analyse the SSCI booths' implementation - that is, a modified TAM. In Figure 11, a modified TAM testing model is shown, incorporating additional variables to strengthen the basic TAM model.

As we test the hypotheses of this modified TAM model, we are able to show the general level of acceptance of the SSCI booths.

(a) External Variables

In this investigation, observations of what external variables affect the perceptions of passengers and how

they will affect a passenger's perceived usefulness and ease of use as to the SSCI booths are conducted. Observation has shown that when one is shown the process of SSCI, one will then feel more comfortable in using an SSCI booth. At this point, the hypotheses to be tested are as follows:

(H1a) The perceived usefulness of the SSCI booth is positively influenced by external stimuli.

(H1b) The perceived ease of use of the SSCI booth is positively influenced by external stimuli.

(b) Perceived Usefulness and Perceived Ease of Use

The attitude of the passenger is assumed to be affected by the perceived usefulness and ease of use of the SSCI booth. Passengers' attitudes will be adjusted either positively or negatively based on their perceived usefulness and ease of use as to the SSCI booth. In this part of the model, we assumed the following:

(H2a) The perceived usefulness of the SSCI booth positively influences passengers' attitudes toward adopting the SSCI booth.

(H2b) The perceived usefulness of the SSCI booth positively influences passengers' intentions to adopt the SSCI booth.

(H3a) The perceived ease of use of the SSCI booth positively influences the perceived usefulness of the SSCI booth.

(H3b) The perceived ease of use of the kiosk positively influences passengers' attitudes toward adopting the SSCI booth.

(c) Perceived Service Quality

The perceived service quality is the measure of the degree to which a person believes in the reliability, accuracy and adequacy of the performance of the SSCI booth.

(H4) The perceived service quality in using the SSCI booth has a positive effect on attitudes.

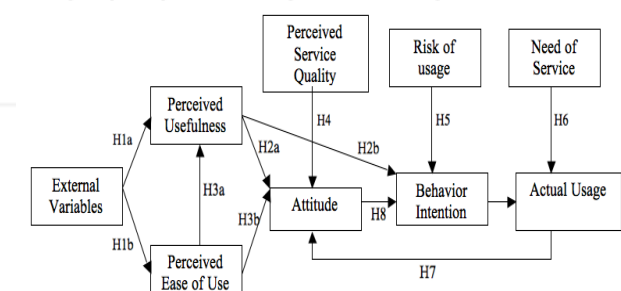

Figure 11. Modified TAM Testing Model

(d) Risk of Usage

The use of the SSCI booth for check-in requires passengers' personal data. Data transmission security is thus important and must be ensured. It is also clear that some passengers tend to be troubled as to possible errors while operating the kiosk. It is assumed that the

perceived risk of using self-service technology will have a negative impact on behavioural intentions.

(H5) The perceived risk of using the SSCI booth has a negative effect on behavioural intentions.

(e) Need for Service

It is no surprise that some passengers would prefer to choose manual check-in service rather than self-service, even if it would mean a long waiting time, as they believe that their needs will more easily be satisfied when interacting with front-line employees. It is assumed that an individual's need for interaction with employees could transmit a negative impact on passenger intentions.

(H6) A need for employee services has a negative effect on behavioural intentions.

(f) Actual Usage

Passengers who have experience in using the SSCI booth actually reinforced their attitude towards the use of SSCI booths. The experience they had with the booth is assumed to be positive, such that they feel comfortable in using SSCI booths. As such, repetitive use will affect their attitudes positively.

(H7) Actual usage has a positive effect on the attitudes of passengers.

(g) Attitude

Attitude is a settled way of thinking or feeling towards a specific thing. It is assumed that individuals' attitudes toward a specific system will obviously and positively affect their intention to adopt SSCI booths.

(H8) Passengers' attitudes towards the kiosk have a positive effect on behavioural intentions.

To fulfil this analysis, a survey is conducted at Singapore Changi Airport Terminal 3, along the belt of Singapore Airlines' operation. A total of 150 personal interviews are conducted. With the voiding of four incomplete surveys, a total of 146 surveys are used for analysis. In order to obtain a wider diversity in the demographic sample, the survey is conducted on over a span of three sessions per day (morning, afternoon and evening) over two days. The personal interviews were conducted through a 31 question survey. These questions contribute to the hypotheses testing of the modified TAM. Incomplete forms were deemed as void. Besides this, in prompting for more information, the questions are weighted by a Likert scale with seven anchor points.

After conducting 150 interviews, a detailed set of results was obtained. From this set of results, we could therefore put the hypotheses to test. First, Cronbach's Alpha is determined for every question so as to test the results reliability. Cronbach's Alpha is commonly used as a measure of the internal consistency and reliability of a psychometric instrument. Cronbach's Alpha ranges

between 0 and 1. In this case, all the hypotheses tested scored above 0.9. Hence, the results obtained are consistent. In table 4, the mean, standard deviation, variance and Cronbach's Alpha values are shown:

Hypotheses	Mean	Standard Deviation	Variance	Cronbach's Alpha
H1a	4.4292	0.037417	0.0014	0.9772
H1b	4.4728	0.04	0.0016	0.9771
H2a	4.9932	0.041231	0.0017	0.9773
H2b	4.6164	0.037417	0.0014	0.9773
H3a	4.4966	0.037417	0.0014	0.9771
H3b	4.7945	0.038873	0.0015	0.9772
H4	4.1018	0.037417	0.0014	0.9773
H5	3.6712	0.037417	0.0014	0.9772
H6	4.7603	0.037417	0.0015	0.9772
H7	4.8973	0.04	0.0016	0.9773
H8	4.3379	0.041231	0.0014	0.9772

Table 4. Results of Interviews of Passengers

We adopt a Likert scale of seven anchor points, with a neutral point of four. Figure 12 shows the modified TAM, which illustrates the relationship between the individual variables. The values are derived from carrying out simple regression using the survey data in order to find the regression coefficient so as to construct a least squares regression equation between the independent variable and the dependent variable. The p-values for these tests are reported as less than 0.01, which implies that these coefficients obtained are significantly different from zero. The regression tests enable us to observe the positive or negative nature of the relationship between the variables, and the results obtained provide proof to support the hypotheses - with the exception of H5 - that the perceived risk of using the kiosk has a negative effect on behavioural intentions. Table 5 summarizes the hypothesis testing results.

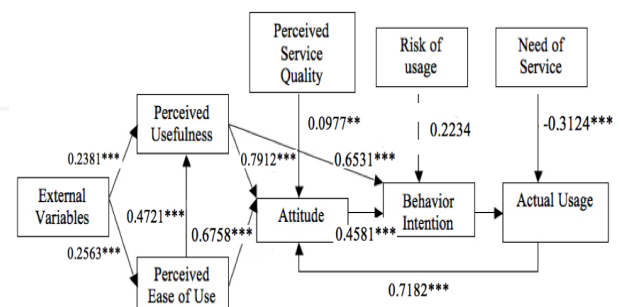

Figure 12. Modified TAM with Results

From the results shown in figure 12, we are able to draw some conclusions based on the modified TAM adopted by this research:

- 1) External variables are factors that influenced the perceived usefulness and ease of use of the SSCI booths. It is important for management to identify

new or existing external variables that will have an impact on the perceived usefulness and ease of use of the booths.

- 2) The regression coefficient obtained for the test between the independent variable (perceived usefulness) and the dependent variable (attitude) represents the rate of change of attitude as a function of a change of perceived usefulness. A high value of 0.7912 implies the strong and direct impact of perceived usefulness on attitudes and, thereafter, the behavioural intentions of passengers. The perceived usefulness of the SSCI booths has a strong positive and direct impact on attitudes and the behavioural intentions of passengers. In another words, if the booths appear to be useful to passengers, it is likely that they will accept the technology and start using it to check-in.
- 3) The perceived ease of usage has a positive and direct impact on the usefulness of the SSCI booths. This is obvious, as the ease of usage will definitely make the booths appear to be more useful. Hence, the attitudes of passengers also have a direct impact, as passengers feel that it is easy to use the SSCI booths.
- 4) The relation between the perceived service quality and the passengers' attitudes has a regression value of 0.0977. This value is relatively low, which goes to show that the performance and the service quality of the SSCI booths may not be as strongly related when compared to the ease of usage and usefulness of the booths.
- 5) The hypothesis of the risk of usage having a negative effect on passengers' intentions is not true. Having value of 0.2234, it shows that passengers are not worried about the risk of usage and that it will not have a negative effect on passengers' intentions.
- 6) The need for service does indeed have a negative and significant effect on actual usage. This is observed insofar as there are situations in which passengers will need an employee's assistance and that is what the SSCI booths are not able to provide.
- 7) This survey also shows that the actual usage of the SSCI booths actually has a positive and significant impact on the attitudes of passengers. Being familiarized with the system, it is likely that the passengers' attitudes towards the system will be reinforced.
- 8) Finally, the attitudes of passengers have a positive and direct influence in the behavioural intentions of passengers. If a passenger feels that the SSCI is generally a better option for him, he will be likely to use the SSCI booth.

With this modified TAM, it is possible to know how well the passengers at Singapore Changi Airport accept the SSCI system. It is shown that, given the right external variables and provided that the SSCI system serves the needs of passengers, it is highly likely that they will

accept the SSCI system. It is also shown that the passengers are not worried about the reliability of the SSCI booths. The perceived risk of usage is actually small. This means that passengers have a high degree of confidence in the SSCI booths. Finally, it is important to implement measures to encourage the usage of SSCI booths, as repetitive usage has a positive impact on the attitudes of passengers. This will bring about a larger percentage of usage in the future.

Hypotheses	Details	Supported/Unsupported
H1a	The perceived usefulness of the SSCI booth is positively influenced by external stimuli.	Supported
H1b	The perceived ease of use of the SSCI booth is positively influenced by external stimuli.	Supported
H2a	The perceived usefulness of the kiosk positively influences passengers' attitudes toward adopting the SSCI booth.	Supported
H2b	The perceived usefulness of the kiosk positively influences passengers' intentions to adopt the SSCI booth.	Supported
H3a	The perceived ease of use of the SSCI booth positively influences the perceived usefulness of the SSCI booth.	Supported
H3b	The perceived ease of use of the SSCI booth positively influences passengers' attitudes toward adopting the SSCI booth.	Supported
H4	The perceived service quality in using the SSCI booth has a positive effect on attitudes.	Supported
H5	The perceived risk of using the kiosk has a negative effect on behavioural intentions.	Unsupported
H6	The need for employee services has a negative effect on behavioural intentions.	Supported
H7	Actual usage has a positive effect on the attitudes of passengers.	Supported
H8	Passengers' attitudes toward the SSCI booth have a positive effect on behavioural intentions.	Supported

Table 5. Hypotheses Testing Result

5. Conclusion

In this research, an attempt is made to investigate the actual improvement that SSCI booths brought to the passenger processing procedure. Our investigation is based on two approaches: one quantitative and the other qualitative.

In order to find out how efficient the SSCI booths are, empirical observations were made and, subsequently, data from the observations were put into simulation software to further process the quantitative analysis of the SSCI booths. It is shown that running a passenger processing operation with SSCI booths indeed decreased the APT and the queuing time, while it also increased the number of people processed in a given amount of time. This shows that SSCI booths are efficient in improving the passenger processing operation. However, in this investigation the data collected for the simulation were only for one sample flight. In order to have a more accurate result, the investigation should be based on a larger sample size. If permission were to be granted, the recording of the check-in terminal could provide results down to the seconds and accurate data could be derived from these recordings.

In the qualitative aspect, this investigation used the TAM to analyse how the passengers accepted the SSCI concept. Based on pre-assumed hypotheses that are informed by empirical observations, a survey was set up to interview 150 passengers to find out the extent to which passengers accept the SSCI concept and their feedback.

With the modified TAM, the survey shows that the modified TAM is strong and that the hypotheses of relationships between different parts of the model are mostly correct. Since the modified TAM is established, we validate 7 hypothesis and made recommendations to help increase the volume of usage. These recommendations are suggested from passengers who were interviewed in the survey.

In terms of qualitative efficiency, this is difficult to measure as there was only a small percentage of passengers who used the SSCI booths. However, amongst those who did use them, none experienced difficulties. Further investigation could be done in interviewing a higher volume of passengers who had used the SSCI booths.

To conclude this investigation, the potential of the SSCI booths in Singapore Changi Airport could be further utilized so as to achieve an optimal point. The most crucial measure to take would be to increase the volume of usage in order to further exploit its potential. SSCI booths do indeed bring about more efficiency in the

passenger processing operation, which saves airline operators money and also provides passengers with more convenience.

6. References

- [1] Singapore Changi Airport News Release (2008). Singapore Changi Airport Registers Growth in Passenger Traffics in 2008, accessed http://www.changiairport.com/Journalist/Press_Releases/2009/news_0008.html?__locale=en&site=null in Apr 2009.
- [2] Miller, P. (2010). Singapore Changi Airport named World's Best Airport in 2010, accessed http://www.worldairportawards.com/Awards_2010/Airport2010.html in Apr 2010.
- [3] The Straits Times (2008). accessed <http://www.straitstimes.com/?a=1> in Apr 2008.
- [4] Airport technology. (2010). The SITA/Air Transport World Passenger Self-Service Survey Looks at Attitudes and Habits of 232 Million Passengers, accessed <http://www.airporttechnology.com/contractors/traffic/sita/press4.html> in Apr. 2010
- [5] Sargent, R. G. (2003). "Verification and validation of simulation models," Winter Simulation Conference.
- [6] Flanagan, J. C. (1954). "The critical incident technique," *Psychological Bulletin* 51(4): 327-358.
- [7] Gremler, D. D. (2004). "The critical incident technique in service research," *Journal of Service Research* 7(1): 65.
- [8] Meuter, M. L., Ostrom, A. L., Bitner, M. J., Roundtree, R. (2003). "The influence of technology anxiety on consumer use and experiences with self-service technologies," *Journal of Business Research*, 56: 899-906.
- [9] Davis, F. D., Bagozzi, R. P., Warshaw, P. R. (1989). "User acceptance of computer technology: a comparison of two theoretical models," *Management Science* 35(8): 982-1003.
- [10] Drennan, J., Kennedy, J., Pisarski, A. (2005). "Factors affecting student attitudes toward flexible online learning in management education," *The Journal of Educational Research* 98(6): 331-338.
- [11] Legris, P., Ingham, J., Collette, P. (2003). "Why do people use information technology? A critical review of the technology acceptance model," *Information and Management* 40(3): 191-204.
- [12] Plouffe, C. R., Hullah, J. S., Vandenbosch, M. (2001). "Research report: Richness versus parsimony in modeling technology adoption decisions--understanding merchant adoption of a smart card-based payment system," *Information Systems Research* 12(2): 208.
- [13] Schepers, J. Wetzels, M. (2007). "A meta-analysis of the technology acceptance model: Investigating subjective norm and moderation effects." *Information and Management* 44(1): 90-103.

- [14] Wang, Y.S., Wang, Y.M. Lin, H.H., Tang, T.I. (2003). "Determinants of user acceptance of Internet banking: an empirical study," *International Journal of Service Industry Management* 14(5): 501-519.
- [15] Ajzen, I. (1991). "The theory of planned behavior," *Organizational Behavior and Human Decision Processes* 50(2): 179-211.
- [16] Moore, G. C., Benbasat, I. (1991). "Development of an instrument to measure the perceptions of adopting an information technology innovation," *Information Systems Research* 2(3): 192-222.
- [17] Fishbein, M., Ajzen, I., Belief, A. (1975). *Intention and Behavior: an Introduction to Theory and Research*. 1975, Addison-Wesley, Reading, MA.
- [18] Lucas, H. C., Spitler, V. K. (1999). "Technology use and performance: a field study of broker workstations," *Decision Sciences* 30: 291-312.
- [19] Taylor, S., Todd, P. A. (1995). "Understanding information technology usage: a test of competing models," *Information Systems Research* 6: 144-176.
- [20] Jackson, C. M., Chow, S., Leitch, R. A. (1997). "Toward an understanding of the behavioural intentions to use an information system," *Decision Sciences* 28: 357-389.
- [21] Karahanna, E., Straub, D. W. (1999). "The psychological origins of perceived usefulness and ease-of-use," *Information and Management* 35(4): 237-250.

INTECH

INTECH