

TRANSFORMERS MAGAZINE

ISSN 1849-3319 (Print) ISSN 1849-7268 (Digital)

EDITORIAL BOARD

Editor-in-Chief:

Mladen Banovic, PhD, Merit Media Int., Croatia
mladen.banovic@transformers-magazine.com

EXECUTIVE EDITORS

Michel Duval, PhD, Hydro Quebec, Canada

Jean Sanchez, PhD, Utility, France

Jin Sim, Jin Sim & Associates, Inc., USA

Juliano Montanha, SIEMENS, Brazil

Craig Adams, TRAFIX, Australia

Arne Petersen, AP Consulting, Australia

Michael Krüger, OMICRON electronics GmbH, Austria

Zhao Yongzhi, Shandong Electrical Engineering & Equipment Group Co., Ltd, China

Art Director: Momir Blazek

Photo: Shutterstock.com

Front page: Cover image by Maschinenfabrik Reinhausen GmbH

Language Editor: Marina C. Williams

ADVERTISING AND SUBSCRIPTION

Marin A. Dugandzic

+44 20 373 474 69

marin.dugandzic@merit-media.com

TRANSFORMERS MAGAZINE

Transformers Magazine is published quarterly by Merit Media Int. d.o.o., Setaliste 150. brigade 10, 10 090 Zagreb, Croatia. Published articles don't represent official position of Merit Media Int. d.o.o. Merit Media Int. d.o.o. is not responsible for the content. The responsibility for articles rests upon the authors, and the responsibility for ads rests upon advertisers. Manuscripts, photos and other submitted documents are not returned.

Subscription rates:

Print edition: \$96 (1 year, 4 issues)

Digital edition: \$54 (1 year, 4 issues)

Online edition - full access: \$19 (1 year, 4 issues)

Online edition - free access: free of charge for registered users

www.transformers-magazine.com

REPRINT

Libraries are permitted to photocopy for the private use of patrons. Abstracting is permitted with credit to the source. A per-copy fee must be paid to the Publisher, contact Subscription. For other copying or republication permissions, contact Subscription. All rights reserved.

Publisher: Merit Media Int. d.o.o.

Setaliste 150. brigade 10,

10 090 Zagreb, Croatia

Contact: +385 1 7899 507

Contact: +44 20 373 474 69 UK

VAT number: HRO9122628912

www.transformers-magazine.com

Bank name: Zagrebacka banka

Bank identifier code: ZBAHR2X

Bank IBAN: HR8023600001102375121

Director: Ana Jelcic

This issue is printed with the support of Ministry of Science, Education and Sports of the Republic of Croatia

www.transformers-magazine.com

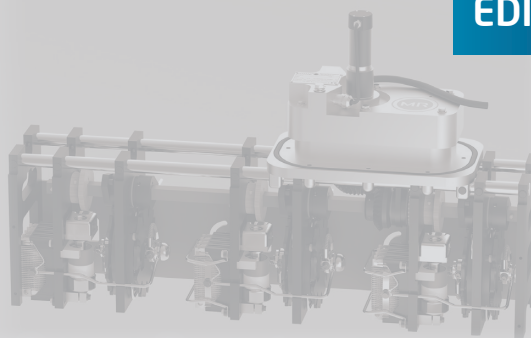

Dear Readers,

In the Editorial message for the April issue, I wrote about a common interest in forecasting the market and industry trends, and pointed to grid investments of nearly USD750B in the first quarter of this year, which were all announced and covered in our breaking news, as one potential indicator of the future business. Since then we have published announcements on additional investments valued at more than USD1 trillion. While these announcements do not offer a foundation for accurate predictions, they inform our readers on the geographical areas of large investments and enable them to timely prepare for tenders. This is exactly what I hear, especially from the sales people, readers like about Transformers Magazine.

Our e-Bulletin is a very practical tool to keep updated with all developments on the global scene. This weekly publication will save you a lot of time, making all publicly accessible information available at a glance. Therefore, I would like to invite all our readers who haven't subscribed to the e-Bulletin to do so as soon as possible, and encourage their colleagues, too. The registration is free and very quick to do – all that is necessary is to provide your name and email address at: www.transformers-magazine.com/e-bulletin

For readers looking to gain a deeper insight into the market, I recommend reading the market review [article](#).

Over the past three months, in the business sector we have seen a few acquisitions – the largest being the acquisition of Crompton Greaves' T&D business, and several new plants opened – such as the new GE's instrument transformer facility in Florida. More new plants have been announced, as well as some potentially big sales such as SGB, Tata Steels UK business, etc.

Some new technology concepts have also been announced, such as new transformer core technology and high efficiency shielded toroidal transformers. The new transformer core technology uses a low-temperature FAST technique (field-assisted sintering technique), which enables direct creation of perfectly sized cores from raw starting materials (iron nitride powders) which don't require any machining, promising significant savings.

But let's get back to technical issues. Transformers

Magazine has been receiving more and more manuscripts for technical articles. While this doesn't affect or slow down our review process, it may mean that an article will not be due for publication immediately after the review process has finished, but in the next available issue. This is important for authors who would like to have their articles published in a specific issue, and who are thus encouraged to check submission deadlines for their manuscripts with our editorial staff.

A lot of our recent communication with readers and authors has regarded natural and synthetic esters, voltage regulated distribution transformers and grid resiliency, suggesting that there is a lot of activity surrounding these topics.

The communication with organizers of conferences, seminars and other transformer related events is also increasing, indicating that there is a growing awareness of importance of networking and global visibility, both for business and professional development. In this respect, using the opportunities available through Transformers Magazine and its channels (website, e-Bulletin, breaking news, etc.), and combining them with those provided by [Transformers Forum](#), an ever-growing community of 19,000 members worldwide, will create a synergistic effect and enhance your chances for networking and global visibility. It is thus no wonder that more and more people from the industry take advantage of these opportunities.

The combined audience of Transformers Magazine and Transformers Forum spreads across nearly 190 countries, making them two truly global platforms with all the associated benefits for readers and users.

This issue of Transformers Magazine brings an overview of most important news, and features two interesting interviews, a profile of the Centre of Excellence for Transformers, several technical articles and a few advertorials. All pieces provide a lot of technical and business-related content, which I hope you will enjoy.

Have a pleasant reading!

Mladen Banovic, Editor-in-Chief