

# Network Simulation and Performance Evaluation of WiMAX Extensions for Isolated Research Data Networks

Thomas Michael Bohnert<sup>1</sup>, Jakub Jakubiak<sup>2</sup>, Marcos Katz<sup>3</sup>, Yevgeni Koucheryavy<sup>2</sup>, Edmundo Monteiro<sup>1</sup>, and Eugen Borcoci<sup>4</sup>

Original scientific paper

**Abstract:** IEEE 802.16 is yet a very recent technology and released hardware does frequently only support standards partially. The same applies to public available simulation tools, in particular for NS-2. As the latter is the de-facto standard in science and as we use it for our research in the context of the WEIRD project, we evaluate the IEEE 802.16 support for NS-2. We present several general but also specific issues, which are important in order to carry out reliable research based on these tools. In particular, we show in much detail where modules deviate significantly and even fail totally.

**Index terms:** WiMAX, IEEE 802.16, NS-2, simulation, WEIRD

## I. INTRODUCTION

There is broad consensus among manufactures service and network operators about the Internet being the sole future communication infrastructure. Indeed, Internet Service Providers (ISP) continuously upgrade their networks with ever more powerful appliances in order to serve a dynamic and competitive market exhibiting a sustainable growth in demand. This in turn stipulates ever more bandwidth greedy services, like the much cited future of the World Wide Web (WWW), the Web 2.0, which in turn raise requirements on support by the underlying network. Altogether indicators for a healthy market place.

But ubiquitous, reliable and fast Internet access does not only foster the introduction of new services. It also motivates the consolidation of services traditionally delivered over dedicated distribution networks.

Surely the most popular as intuitive example is telephony, which has been originally transmitted over the Public Switched Telephone Network (PSTN) but nowadays is being provided more and more over the Internet infrastructure. Convergence and its inherent positive synergy effect on revenue is the obvious motivation and indeed, the distribution of shares on the latter is subject to a fierce dispute [1].

Naturally, user expectations on service quality and availability do not change if a service provider decides to change its underlying network infrastructure. As a consequence thereof, coming back to the telephony example and in times of cellular networks, customers do expect the same "Anytime, Anywhere" experience when they subscribe to a Voice over IP (VoIP) service as they are used to from PSTN.

The above mentioned is just one example why Broadband Wireless Access (BWA) is becoming increasingly important as last mile access technology. In fact there are ample more and their early precursors have been sensed by service providers, operators, and manufacturers already few years ago. Consequently, standardization has been initiated and the IEEE 802.16 MAN family [2, 3] is certainly the most powerful candidate recently finalized and published. Once available, manufacturers took on and first products have been released recently. Furthermore, an industry exclusive initiative named WiMAX Forum has been founded mainly to promote products and ensure interoperability. Part of this work is the definition of a Network Reference Model (NRM), which is a complete "All IP End-to-End" infrastructure based on IEEE 802.16 as access technology [4, 5] in order to interface with existing cellular networks.

Although labeled as the future of BWA, IEEE 802.16 deployment is yet in an early stage. Principal reason is its novelty and henceforth, the advancement of this matter recently has motivated many research initiatives. One of them is the European research project called "WiMAX Extensions for Remote and Isolated Research Data Networks (WEIRD)" [6]. As the name implies, the aim of the WEIRD project is to deploy, evaluate and enhance WiMAX technology as access technology for a set of European research units with remote and impervious test-beds. These sites are interconnected by the European research backbone network GANT2 [7] and

Manuscript received December, 2007 and revised February, 2008.

This Paper was presented as part at the Next Generation Teletraffic and Wired/Wireless Advanced Networking (NEW2AN) 2007

This research has been jointly supported by the EU IST Integrated Project WEIRD (WiMAX Extensions for Remote and Isolated Data Networks) and ESF COST 290 Action.

Authors are with (1) University of Coimbra, e-mail: (tbohnert, edmundo@dei.uc.pt); (2) Tampere University of Technology, e-mail: (yk@cs.tut.fi, jakub.jakubiak@tut.fi); (3) VTT Technical Research Centre of Finland, e-mail: (marcos.katz@vtt.fi); (4) University Politehnica of Bucharest, e-mail: (eugen.borcoci@elcom.pub.ro)

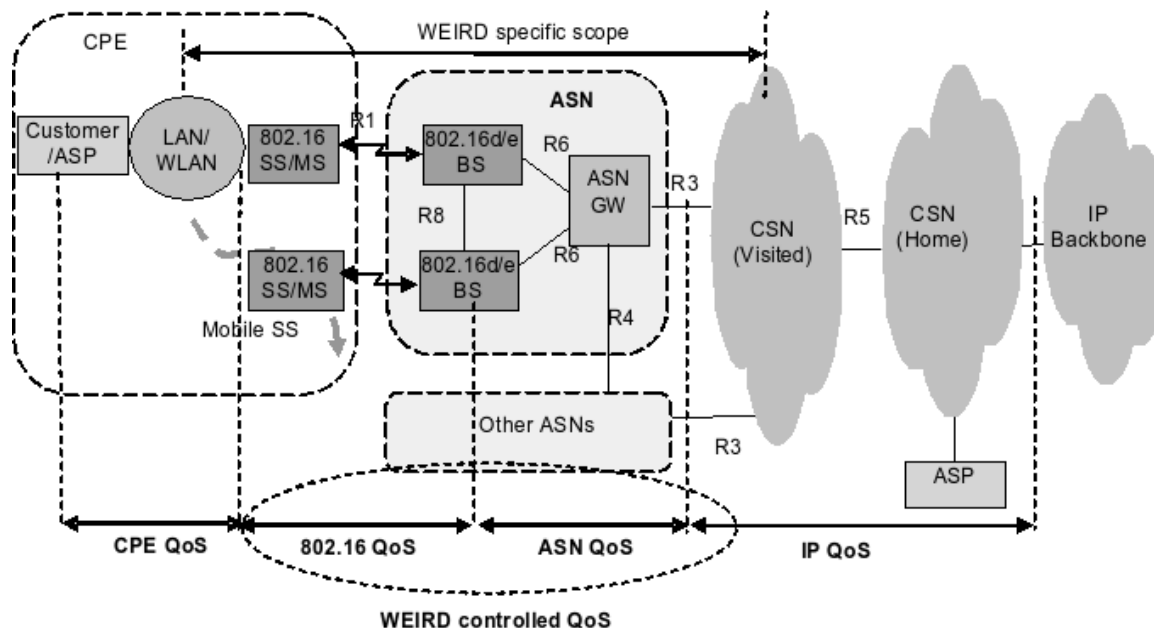

Fig. 1. Simplified WEIRD Overall Network Infrastructure

relevant National Research and Education Networks (NRENs). Hence the project network is a Europe wide, complete end-to-end network with WiMAX as access technology.

In brief, the project defines an extended architecture based on the NRM and latest hardware appliances for the radio access network, i.e. WiMAX Base, Subscriber and Mobile Stations (BS, SS, MS). In accordance with each testbed's purpose, it defines a set of evaluation scenarios in order to scrutinize WiMAX technology under most challenging conditions. For instance, WiMAX is used to provide BWA to a Forest Fire Monitoring site in the Serra de Lousa, an impervious set of mountains in the heart of Portugal, which is prone to devastating forest fires during summer term. Different field monitoring sites are connected via WiMAX to sense precursors of fire outbreak and in case, to support the coordination of the fire brigades emergency actions by delivering high definition images to field personnel and VoIP for communication. Later in this paper, we present some of the scenarios in greater detail but the subject treated as a whole can be found in [8].

As mentioned above, one focus of WEIRD project is to look beyond the horizon of currently available standards, specifications and implementations. In particular for WEIRD, this means to deploy WiMAX network, evaluate its performance, identify shortcomings and devise appropriate solutions and prototypes to improve this technology in different dimensions. Naturally, carrying out these works in real systems is a complex and lengthy task and prevents rapid progress. Hence, network simulation has become the standard means for proof of concept and early stage prototyping in the last years.

But rapid innovation was not the only motivation to integrate networks simulations in WEIRD. Another reason was the ability to overcome access restrictions to WiMAX internals. In fact, as WiMAX is an emerging, very powerful technology, manufacturers are not willing to provide full access to hardware and implementation internals, i.e. their hardware drivers or detailed documentation. Moreover, many of the currently available hardware pieces are rather prototypes, hence often they do not fully support all the features defined within the standards.

Given that aforementioned, in this paper we present our first results on WiMAX network simulation based on the de-facto Open Source standard tool in science, the Network Simulator 2, short NS-2 [9]. We have also experimented with the OPNET Modeler WiMAX module, a commercial simulation environment offered by the Opnet Technologies Inc, [28]. By today, three ns-2 IEEE 802.16 modules have been released public, one by United States' National Institute of Standards and Technology (NIST) [10], another one by the Networks and Distributed Systems Laboratory (NDSL), part of the Chang Gung University in Taiwan [11] and one from the University of Pisa [22]. By far for equal reasons as applying to WiMAX hardware, these modules are yet in early stages and do not implement all standardized features of the IEEE 802.16 standard. Hence, the very first work of the WEIRD simulation track was to scrutinize the applicability and utility of these modules and these results are presented in the sequel of this paper.

The paper is has been structured as follows. In Sec. 2 we present the WEIRD project and its architecture in more detail. Later on we evaluate two different WEIRD scenarios, first one using both the NIST module and OPNET Modeler

module, see Sec. 3, and another one using the NDSL module, Sec. 4. Thereafter we conclude our work in Sec. 5 and close the paper.

## II. THE WEIRD SYSTEM, OBJECTIVES AND ARCHITECTURE

The WEIRD system aims to be a part of full multi-domain network architecture, allowing fixed and mobile access in new scenarios. Among others, WEIRD targets end-to-end QoS enabled services. The WEIRD business models should support different entities; each of them may offer high level services or connectivity services, in the access and/or core transport. The proposed architecture allows the organizational and technical independence of the entities managing the network domains: Network Access Provider (NAP), Core Network Service Provider (NSP), etc. Therefore, the internal policies, management and control of each domain are independent on other domains. The WEIRD system is built upon a networking infrastructure, presented in Fig 1.

As illustrated, the architecture is made of three components which could be managed by different business entities, namely Customer Premises Equipment (CPE), Access Service Network (ASN) and Connectivity Service Network (CSN). They may be located within CPE or linked to the CSN, in case of Application Service Providers (ASP). The infrastructure includes the mobility support. Figure 1 has been simplified and abstracted in order to emphasize generic interfaces between entities as defined in the WiMAX Forum terminology, denoted by R1, R2,..R8 and fully described in [4]. The CPE can be composed of single-user SS or multiple users SSs (MS), in case that an SS offers access to LANS/WLANs having several users/hosts. The fixed or mobile SSs are wireless linked with Base Stations (BS). An ASN, linked through an ASN Gateway (ASN-GW) to the CSN, may control and aggregate several BSs, based on a wireline or wireless IP infrastructure. The ASN-GW plays here both the data gateway and the control role for ASN. In a mobile environment the CSN may be the Home CSN or Visited CSN respectively. Connectivity with other networks may be realized via IP backbone. Application entities clients and/or servers can exist in the CPE side or in CSN networks. In WiMAX forum model also direct interfaces between different ASNs may exist (denoted by R4).

The goal of the considered architecture is, among others, to control and ensure end-to-end QoS enabled services. WEIRD should achieve and control QoS in its scope: WiMAX segment and in ASN. To do this WEIRD defines corresponding interfaces with CPE and CSN and run appropriate QoS oriented signaling onto these interfaces. The WEIRD system offers different levels of QoS to the high level services/applications while using the IEEE 802.16 classes of services (Unsolicited Grant Service (UGS), real time Polling Service (rtPS), extended real time Polling Service (ertPS), non real time Polling Service (nrtPS) and Best Effort (BE)). This

architecture supports different applications, capable or not to signal their QoS requirements (SIP/non-SIP based applications, legacy, etc.) by offering appropriate Application Programming Interfaces (APIs).

The overall WEIRD architecture is structured as a multi-plane. It is fully described in [12]. Vertically there are two macro-layers, or strata, i.e., Application and Service Macro-Layer/Stratum and Transport Macro-Layer/Stratum. Horizontally, there are three planes: Management (MPI), Control (CPI) and Transport/Data Plane (DPI). This structuring aims to decouple the applications and high level services from transport technologies, in order to support heterogeneity of the core and access network technologies [13, 14]. The Applications and Service Stratum include the layers and functions for management, control and also operations on data independently of network transport. The applications generally have a graphical user interface (GUI), a media module and signaling modules. Some applications are QoS signaling-capable (based on SIP or other protocols). Legacy applications are supported by a specially defined WEIRD agent, capable to signal their requirements. The WEIRD API Interface adapts the applications data and control owes to the Transport Stratum. Transport Macro-Layer/Stratum performs management, control of resources/traffic, as well as data operations in order to transport the information flow through various networking infrastructures. The MPI performs medium- and long-term management functions: for high level service management at the Application and Service Layer macro-layer and resource and traffic management at Transport macro layer. It provides coordination between all the planes. The CPI layers perform short-term control actions. In the Services and Applications Stratum the CPI sets up and releases connections, restores a connection in case of a failure; in the Transport Stratum, the CPI performs the short term actions for resource control and possible and traffic engineering and control, including routing. The DPI transfers the user/application data but also the control and management related data between the respective entities. The DPI may include functions and mechanisms to act upon the transported packets.

Fig. 2 shows a high level view of the basic WEIRD control plane architecture. The Control Plane architecture horizontally covers the following entities: SS/MS, ASN(BS, ASN-GW) and CSN. The Application and Service Stratum contains mainly the session signaling (e.g., SIP), including SIP agents and AAA functions. The Transport Stratum contains the layers: Connectivity Service Control as a layer of blocks with specific internal structure for SS, SN-GW and CSN. The main focus of WEIRD is on WiMAX and ASN network control, therefore CSC-ASN is the most important control block; QoS signaling based on NSIS signaling as QoS messages vehicle; Mobility Control, including micro and macro mobility based on Mobile IP and Resource Control which is the lower layer

having the task to install resources in the network segments. Fig. 2 does not include the RC for CPE network and CSN because these are specific to the CPE and CSN technologies. In case of WIMAX the RC communicates with WRC via SNMP in order to install Service Flows in WiMAX segment. A detailed description of the control architecture is given in [13, 14].

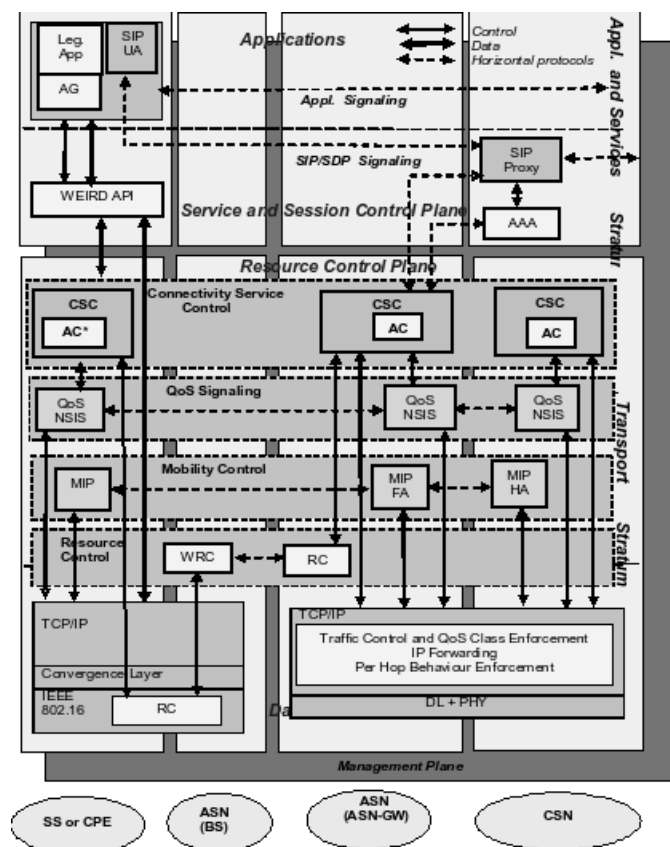

Fig. 2. WEIRD Control Plane Architecture: UA: User Agent; SIP: Session Initiation Protocol; API: Application Programmer Interface; CSC: Connectivity Service Controller; AC: Admission Control; AC\* this will exist only in an SS which manages multiple users in order to control the CPE segment resource allocation; NSIS: Next Step in Signaling Modules; MIP: Mobile IP; (W)RC: (WiMAX) Resource Controller

WEIRD approach for QoS resource control is dynamic, based on the idea to reserve/admit/allocate resources, at request, via SIP or NSIS signaling in WiMAX and ASN segments. The requests are checked for Admission Control in CSC. When the Resource Manager of the Management Plane has done beforehand some provisioning (on the path requested), the CSC - ASN will admit/allocate resources (based on Service Flows in WiMAX segment and logical traffic trunks in the ASN part) by taking a part of the available pre-provisioned resources. It is also possible that the request is completely new in terms of its scope; in such case the AC applied by the CSC-ASN, if successful will determine

installation of new service flows and new pipes in ASN. Fig. 3 shows a simplified structure of the Management Plane (MPI). It performs the classical network management functions (NMS) and the medium-long term resource management (RM). NMS/RM is thus composed of two subsystems: Conventional Network Management Systems (CNMS), having classical functions such as network static provisioning, network monitoring, alarm collection and management; Resource Manager which is responsible to manage reservation and allocation of connectivity resources in the ASN and WiMAX segments.

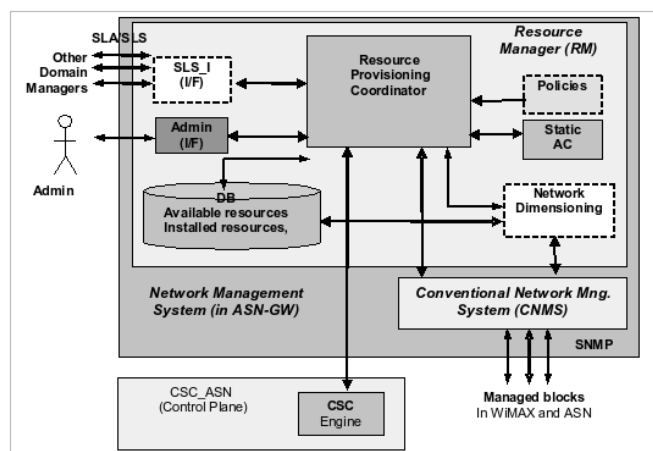

Fig. 3. WEIRD Management Plane.

The resource pre-provisioning is done by management actions, thus preparing in advance the resources to be used in the future by the high level services. The provisioning can be defined for several classes of services offering different QoS levels. From the granularity point of view, the provisioning can be done either at aggregated- (preferable method) or per individual flow in provisioning mode; e.g., individual in the SS-BS zone of the chain; usually at aggregated level in the zones BS-(ASN-GW), (ASN-GW)-CSN and inside or between CSNs. This is the main role of the RM part of the NMS and it falls completely under WEIRD scope. As described above, individual (per call) resource allocations for different flows can be dynamically established at request by the Control Plane, while taking into account the pre-provisioning done previously by RM (in the limits fixed by the RM). The resource provisioning by management is performed based on some forecasting information on future calls amount. The proposed architecture is flexible in the sense that it allows extensions (currently not in the scope of WEIRD): agreements between domain managers can be established by (SLA/SLS), on the amount of resources to be provisioned within each domain or between domains.

Also a Network Dimensioning module can map the physical topology and link capacity information in a logical map of traffic trunks, described as a matrix of virtual pipes, independent of network infrastructure. This permits to define general algorithms for AC and in general for resource control in an independent manner with respect to the networking technology. Details for these are given in [12].

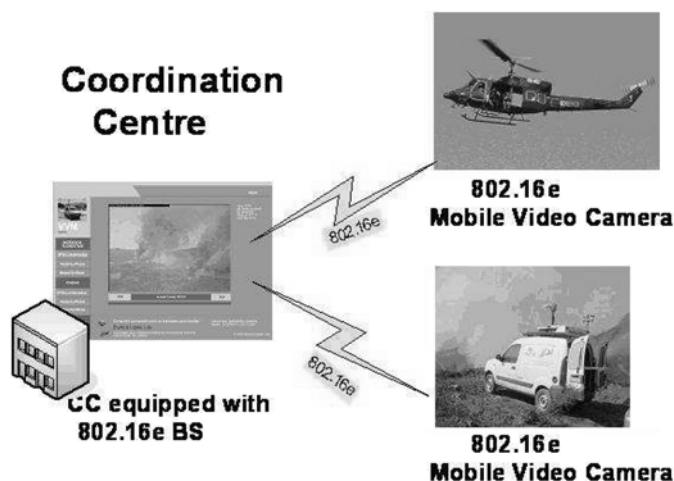

Fig. 4. Scenario scheme based on WEIRD specifications.

### III. SIMULATING THE WEIRD SCENARIO 1: FOREST FIRE PREVENTION

Forest fires render a serious problem in the Mediterranean Basin and currently used methods for fire detection have certain limitations, especially in remote, isolated areas. Thus several pilot projects, developed in Portugal by University of Coimbra, trying to push the use of new technologies in that area. Namely, the traditional fire detection systems are aided by the use of sensors, video and infrared cameras, coordinated remotely. However, the main drawbacks of such systems are usually the costs and limited image quality related to GSM/GPRS communications and the difficulty to implement radio links to transmit video in mountainous regions (both LOS and NLOS links). Therefore deployment of WiMAX network, proposed within the WEIRD project, seems to be most promising solution as communication medium for such an environment. Real-time voice, video and textual data, relayed over WiMAX networks, provides extensive communication means between mobile personnel and the central command station, offering fire fighters an invaluable advantage in managing the field operations.

This particular simulation scenario evaluates the feasibility of fire prevention system based on the following actors: a Coordination Center (CC), a Surveillance Car (SC), a Helicopter (HC) and Base Station (BS). The CC is an entity in charge of fire detection and managing the field operations of

the fire brigade. The SC is a vehicle acting as a mobile watch tower, equipped with digital video camera, GPS receiver and possibly some sensors (wind, humidity, and temperature). It also maintains a VoIP link with the CC. The HC, with equipment similar to that one carried by SC, further improves the effectiveness of field operations. As highly mobile, the HC offers fast information updates under changing conditions and can provide images from top-down perspective, otherwise unavailable.

Based on this general description, our simulation consists of several stages:

- 1) Initially, the SC patrols the remote area, maintaining a VoIP link with the CC. At that point of time the HC is placed closely to the CC, waiting for orders.
- 2) The SC notices a fire! The CC is informed over VoIP, video transmission is started, the vehicle retracts from the endangered area.
- 3) The CC orders the HC to the fire location, video camera mounted on the HC starts transmitting
- 4) While the fire brigade is fighting the fire, the HC revolves around it, monitoring and providing assistance to the fire fighter officers in the field.
- 5) As soon as the fire is extinguished, all video transmission is suspended and the helicopter returns to its base

As mentioned before, all the traffic is relayed over the BS station installed on the top of a nearby hill. Figure 4 illustrates the basic connection scheme (Base Station not included).

In order to simulate this scenario we chose the NIST module as it, in contrast to NDSL, comes with IEEE 802.16 mobility support. To be more specific, the prerelease-092206 is based on the IEEE 802.16 standard (802.16-2004) [2] and the 802.16e-2005 [3] mobility extensions, including neighbor advertisement, scanning and handovers. While providing excellent mobility support, QoS features are yet totally left out. The default scheduler does not support any service classes' differentiation but uses a simple first-in-first-served (FIFS) scheme for DL and Round Robin for UL traffic. In brief, according to the [15], the module implements several features where the most relevant are

- WirelessMAN-OFDM physical layer with configurable modulation
- Time Division Duplexing (TDD)
- Management messages to execute network entry (without authentication)
- Fragmentation and reassembly of frames

The module allows to adjust parameters such as modulation scheme, cyclic prefix, contention period length or frequency band width, which influence the achievable throughput boundaries. In order to illustrate this, we have run several simple and preliminary "MS to BS" simulations for a 7 Mhz channel. The results of this test run are presented in Fig. 5. As it can be noted, the achievable data rate is a function of the cyclic prefix length, modulation order and modulation rate.

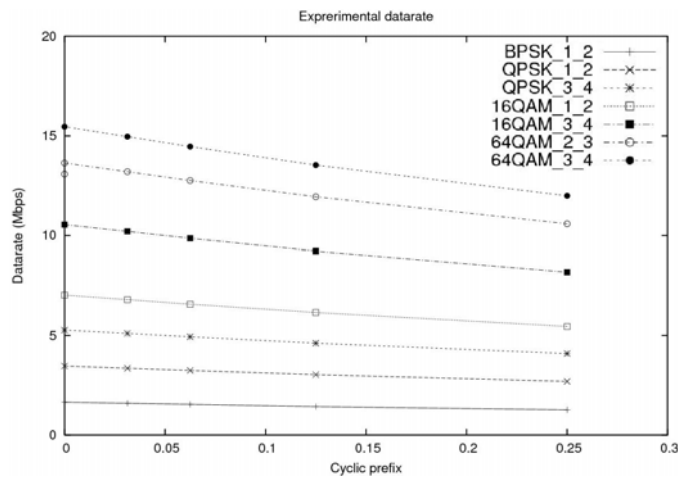

Fig. 5. Data rate as a function of modulation scheme and CP.

Nevertheless, as we found out, those parameters are not subject to dynamic adjustment depending on link quality and (indirectly) on the distance between SSs/MSs and BSs. In fact one can only change those values manually; otherwise defaults are used, meaning that IEEE 802.16 Adaptive Modulation and Coding (AMC) adjustment is yet to be implemented. Moreover, modulation schemes are set in a per BS manner, meaning that all MSs connected to the same BS are forced to deploy the same modulation scheme.

The main goal of this work, however, was to study the feasibility of applying NS-2 with WiMAX modules to simulate WEIRD scenarios. Thus, in this scenario setup the achievable throughput, and therefore the availability of services depending on the bandwidth usage, was investigated. The examined parameters also include the order and rate of modulation, length of contention period and the cyclic prefix length used. Further, one has to note that, since the NIST module offers no IEEE 802.16-2004 QoS model support, the achievable throughput is a question of contention, as, in order to transmit BE data, the competing nodes need to issue BW requests in the contention slots of each IEEE 802.16 frame, see [2, Chap. 6.3.6] for details.

Another simulation environment that covers WiMAX network modeling is OPNET Modeler [28]. Offered by the Opnet Technologies Inc., a well known provider of management software for networks and applications, it incorporates a module that implements the IEEE 802.16-2004 and IEEE 802.16e-2005 standards. It is maintained by the WiMAX Model Development Consortium, with Opnet and Motorola being the founding members, and representatives from several leading technology companies (Samsung, Alcatel-Lucent, France Telecom, NEC).

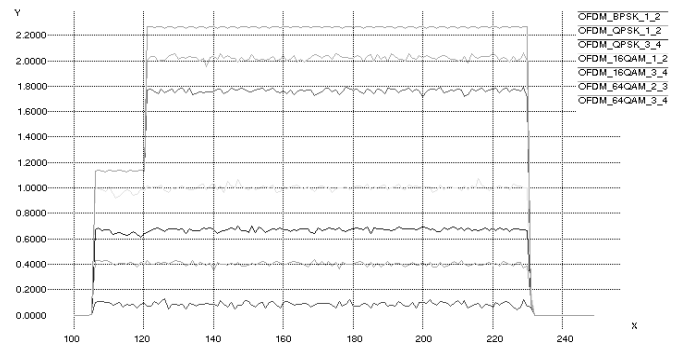

Fig. 6. Video throughput (in Mbit/s) as a function of modulation scheme over time.

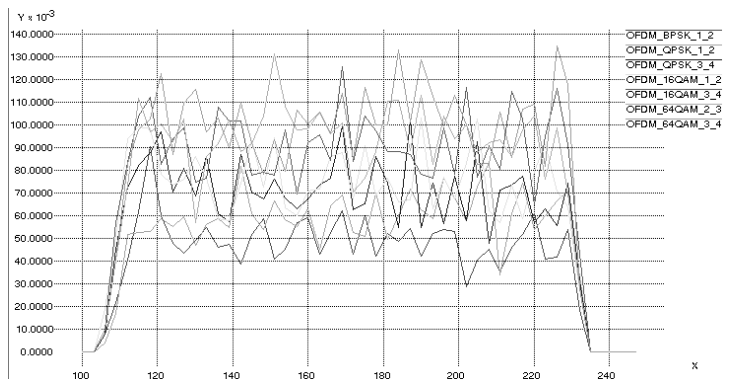

Fig. 7. Voice throughput (in Mbit/s) as a function of modulation scheme over time.

It is the most complete and featured WiMAX model available at the time, however it is a commercial application, resulting in additional license cost (at the moment module is available only for the Consortium members and for educational purposes). Its key features include:

- BS scheduler for uplink and downlink connections
- Support for UGS, ertPS, rtPS, nrtPS, BE
- Adaptive modulation and coding
- MSDU packing and fragmentation
- In-order SDU delivery
- Cumulative ACKs
- Fragmentation and packing
- ARQ and HARQ
- Handoff mechanisms, ASN
- TDD, OFDMA, SOFDMA
- Multiple cell networks, Multi-sector base station

Important feature of the OPNET module is the support for various scheduling algorithms in the MAC layer.

In accordance with available WiMAX equipment by WEIRD, to be specific RedLine (from Juniper), we limited the simulation to BE traffic as no other scheduling service is currently supported by that hardware, in fact one more reason

to use the NIST module for this scenario. The module uses weighted round robin for traffic classes prioritizing, assigning different weights for different traffic classes. The default fraction of contention period assigned for BE traffic was only 20%, and for the simulation we increased it to its maximum value so that all the bandwidth could be used for contending; otherwise most part of the bandwidth would be wasted due to reservation for other, non-existing classes of traffic. In more detail, the following traffic types have been simulated:

- Video transmission: 1 Mbit/s, CBR traffic generator, 2 sources: SC and HC
- VoIP transmission: 64 Kbit/s, exponential on-off traffic generator; 2 bidirectional connections: SC – CC and HC – CC

The total offered traffic is equal to 2304 Kbit/s, where 2048 Kbit/s falls into video traffic and 256 Kbit/s for voice communication. Voice traffic pattern was approximated using the exponential packet distribution, whereas for the video transmission a simple CBR source was used.

The graphs 6 and 7 illustrate the throughput of voice and video traffic as a function of modulation technique. Clearly, one can see from the fluctuations the effect of all nodes competing for bandwidth (in this case no cyclic prefix was used). The results also reveal that the radio channel was not saturated, as packets were dropped due to insufficient bandwidth, which is for BE essentially a function of the contention period length.

The module caused some other problems as well, though not as severe as NDSL – e.g. the MAC layer statistics were not gathered when the `print_stats_switch` was used; the default routing protocol, DSDV, needed extremely long time to converge (over 80 seconds).

Moreover, by default 80% of available bandwidth is assigned to the not yet implemented traffic classes.

The NIST module has several shortcomings and requires additional work to ensure it is both stable and reliable to handle WEIRD scenarios, especially as the module is incomplete - some functionality is still missing (adaptive channel adjustment, traffic prioritizing, ARQ, etc.), other is implemented only optionally or partially (bandwidth scheduler and flow handler). Only recently, soon before the article submission deadline, a new version of module, named prerelease-041507, was published. Authors mention several fixes and some new functions, however due to the tight schedule we were unable to investigate this revision any further.

#### IV. SIMULATING THE WEIRD SCENARIO A3: MONITORING VOLCANIC UNREST

Similar to forest fires, volcanic unrest poses a severe threat for nature and humans. As a pure matter of scale, lava flows can cover areas up to several square kilometers and volcanic ash-plumes reach elevations of tens of kilometers. One such example is the Hekla volcano located in south central Iceland. Being a very active volcano, it has erupted approximately every 10th in the last few decades. In Hekla's particular case

winds volcanic plume and ash falls on farmland in southern Iceland but also on Iceland's northern coast. Furthermore, great elevations of volcanic ash, dispersed over thousands of kilometers in the stratosphere, can cause severe impacts to air-traffic in the Northern Atlantic and Europe.

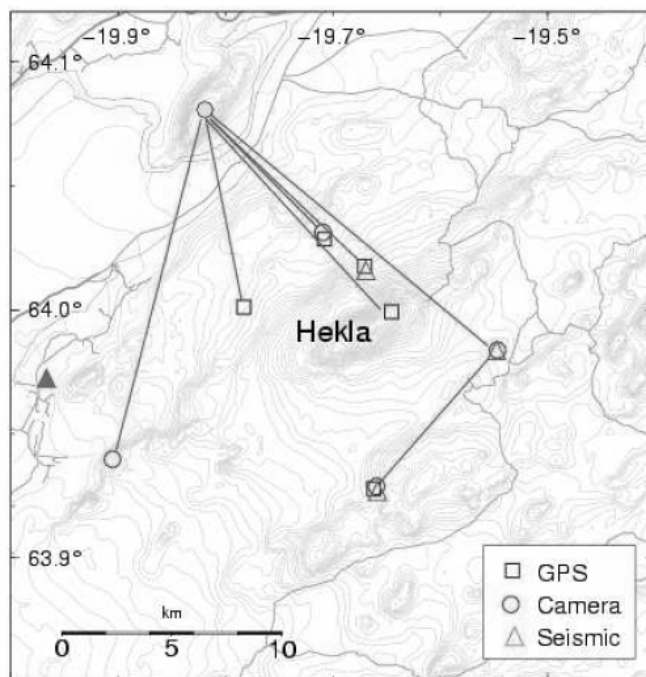

Fig. 8. The Hekla volcano and its vicinity [16].

Although extremely quiet in between of eruptions, precursors, in the form of seismicity and sudden changes in strain, can be observed around one hour in advance. This short but extremely important timeframe allows to launch appropriate preparations and safety measures. Hence, Hekla is being continuously monitored by permanent and mobile stations whose locations are shown in Fig. 8. Besides a single BS (yellow point) there are five permanent, so-called GPS stations plus one seismic station in Hekla's immediate vicinity. In the event of volcanic unrest portable seismic devices are additionally deployed at three locations around the volcano. Video cameras are mounted and used to stream real-time pictures to a CC. The cameras cover the mountain from any perspective but also follow the ascension of the volcanic plume. In addition to video streaming, field personnel, operating during emergency cases, are equipped with VoIP devices in order to communicate among each other but also with the coordination centre [16].

After mounting the portable devices in an emergency case no terminal movement is foreseen. Hence, the NDSL module, version 2.03, released at the 03/14/2007, lends itself for the evaluation of this WEIRD scenario and vice versa. In fact, by pure design choice, this module does not support mobility but is, according to the published module documentation [17], based on [2]. While this is a major difference from the NIST

module, another one is that it supports the IEEE 802.16-2004 QoS model. Further, fragmentation as well as packing has been implemented and its convergence sublayer supports IP address based service flow mapping. The most important features of the physical layer are OFDMA and distance based AMC in accordance with the results published in [18].

The overall objective of this evaluation was twofold. Our first aim was to examine the QoS model for different channel bandwidths in order to see if we can come up with a set of configuration guidelines for the real WEIRD testbed. The second one was to learn how far the module lends itself as basis for our research. Hence, we set a set of simulations according to the map presented in Fig. 8. The same traffic models as for the previous scenario were used and we kept the NDSL standard configuration for the physical as well as MAC layer in order to get comparable results with [17], at least up to some extent.

After running several simulations for slightly different traffic intensities we calculated the bandwidth and discovered several peculiarities. In the first place we found that the trace files slightly differed from the standard (format) for wireless networks [19, Chap. 16.1.7]. Precisely, many packets had the same time stamp (sending time). As this feature has not been documented in [17], and in order to compute exact results, we analyzed the implementation. An immediate observation was that the current design differs much from [17], surely due to many major revisions meanwhile. Nevertheless, as the objective of this paper was to scrutinize the utility of NS-2 WiMAX modules, this finding is a relevant point to be mentioned.

In fact, there is a significant reason behind this feature. The module has been designed in a way that each packet corresponds to one IEEE 802.16 MAC Protocol Data Unit (PDU). With respect to the NS-2 radio propagation models, [19, Chap. 18], this implies that the smallest unit possibly lost is one such PDU. As the PDU size is configurable (100 Byte default) one PDU can encapsulate a single fragment up to many Service Data Units (SDU), in this case basically IP packets. This is in any case a far larger value as the standard metric for radio link simulations, the Bit Error Rate (BER). Consequently, accurate PHY layer performance evaluations are precluded right from the beginning. This conclusion is in line with the findings from [20], which in fact propose a solution for this issue. Further, this explains the equal time stamp for different packets as one IEEE 802.16 frame is made of several MAC PDUs and all packets with equal time stamps therefore belong to a single IEEE 802.16 frame.

After this disclosure we were able to calculate the maximal capacity achievable for various channel settings and we got intriguing results. In short, we were able to achieve unlimited capacity. This indication to an implementation error could be confirmed after some further code analysis. Very briefly, an error in the bandwidth request and assignment management allows to map the whole buffer content of a single MAC connection to a single Bandwidth Information Element (BIE) for the same connection and not just the byte value of this BIE, for details see [2, Chap. 6.3.6]. As IEEE 802.16

connection queues are implemented using NS-2 *PacketQueues*, see [19, Chap. 7.1.2], which are theoretically of unlimited length, we could fill the queue with an unlimited number of packets between two IEEE 802.16 frames, which in turn, mapped to a single BIE, are sent in the next frame. Hence, any offered traffic could be sent in a single IEEE 802.16 frame, practically resulting in unlimited capacity measurements.

There is another significant detail that has been revealed during our analysis. If SDUs are fragmented or packed in PDUs, the standard defines specific headers to be added in order to restore the SDUs correctly at the receiver. The size of these headers has to be taken into account while calculating the net bandwidth granted for a connection's data transmission. The absence of this feature in the current implementation incurs another slight impression in capacity evaluations.

Finally, during our analysis, we found one more or less undocumented feature, with respect to [17]. In fact, although not explicitly mentioned in the text, Fig. 2 in [17] indicates that IEEE 802.16 connection queues are located behind a node's interface queue, essentially meaning a cascade of queues. What is important to understand is that the interface queue is shared by all connections and henceforth masks the "multiple connections, multiple queues" feature defined for IEEE 802.16 nodes. Most probably, packet drops are to be expected at this queue and not at each individual connection's queue (which are currently anyways of infinite length). Naturally, this has several implications for QoS as traffic classes are mapped to connections which therefore should be totally isolated and not share a common pool of resources, in this case the space of the interface queue.

## V. IEEE 802.16D MESH MODE SIMULATIONS

A particular feature of the IEEE 802.16d is the definition of mesh mode operation. In contrast to the centralized Point-to-MultiPoint (PMP) mode, in which any communication between SSs/MSs is relayed by the BS, in mesh mode SSs/MSs can communicate directly with each other. This has several advantages but likely the foremost mentioned generally is the significant coverage expansion achievable by exploiting relay cooperation between individual nodes.

Doubtlessly useful, IEEE 802.16d mesh mode has been subject to dispute right from the beginning. Nevertheless, against considerable objection it was Nokia that pushed this feature until it eventually became part of the standard. Perhaps predictable, however, it turned out (yet another time) that consensus during standardization might be alleged in nature. As of today, mesh mode has failed to gain manufacturer's support. Hence, with no hardware available IEEE 802.16d mesh mode has not become part of WEIRD.



Nevertheless, we briefly detail on IEEE 802.16d mesh mode. This has mainly been motivated by the recent release of an implementation of IEEE 802.16d mesh mode, see [21], and for the sake of presenting a most complete, the state-of-the-art IEEE 802.16 simulation tool. Further, as there is no mesh scenario defined for WEIRD, the evaluation of this module is rather of a descriptive nature.

Released early 2008, the module focuses explicitly on mesh mode. Unfortunately, just like the NDSL module, no explicit documentation is part of the release. But there are a couple of text files with introductory information spread all over. In addition, an informative website provides further information, like for example installation instructions.

With respect to IEEE 802.16d mesh mode conformance, the authors state that the MAC layer has been implemented completely [21]. For example, the *distributed coordination mode* has been implemented and its evaluation can be found in [22]. On top of that, the Fair End-to-end Bandwidth Access (FEBA) scheduler has been implemented [23]. A brief code analysis revealed that the module is rather kept independent from the wireless and mobile implementations shipped as part of the current NS-2 release. For example, as mentioned in [22], it implements its own channel model and the implementation is incompatible with NS-2 routing algorithms. This is rather different from the either NIST or NDSL, which both are based on the NS-2 mobile/wireless implementations.

Apart from these differences, it is worth mentioning that the module comes with several support features, partially results from previous work. For example, a comprehensive VoIP traffic source model together with an integrated QoS evaluation tools set based on Subjective QoS (Mean Opinion Score) [24, 25]. The same applies to capturing and processing simulation results. The module is based on an extension of the NS-2 "stat-utils" package, documented in [26, 27]. It defines an individual trace file format and an extensive statistic tool box, general enough to be employed in future, non-WiMAX modules too.

In conclusion, while largely parting from the common NS-2 wireless and mobile network structures, this module does appear to us well implemented, just as the NIST module. Certainly, the comprehensive body of literature compensates for the lack of an explicit documentation and the comprehensive set of additional features renders it as a high-quality basis for research in IEEE 802.16d mesh operation mode.

## VI. CONCLUSIONS

The major conclusion of this paper is that the current publicly available NS-2 WiMAX modules are to be used with care. In order to produce accurate, reliable and reproducible

results, a sound understanding in wireless network simulation and moreover, the IEEE 802.16 standard details, appears to be absolutely essential. Only when backed up by these prerequisites, the particular features of each module and its interaction with NS-2 become fully obvious. As elaborated in detail in the previous section, this has been particularly important for the NDSL module, which is in its latest release not applicable without a major revision. Undocumented features, deviations, simplifications and abstractions, altogether standard methods in simulation, narrow the applicability of both modules to a few, very specific applications.

Nevertheless, finally we would like to express our sincere gratitude to all development teams, those at NIST, at NDSL and at the University of Pisa for their efforts. Doubtlessly, making their work public available is a major contribution to the research community, especially if a technology is as recent as WiMAX. Moreover, we would like to stress that we intentionally refrain from any "good/bad" or "better/worse" conclusion but would like to see our work understood as a contribution to further improve the quality of both modules and as a helpful support for those deploying them.

## REFERENCES

- [1] T. M. Bohnert, E. Monteiro, M. Curado, A. Fonte, D. Moltchanov, Y. Koucheryavy, and M. Ries, *Internet Quality of Service: A Bigger Picture*, 1st OpenNet QoS Workshop "Service Quality and IP Network Business: Filling the Gap", Diegem, Belgium, March 2007.
- [2] Part 16: Air Interface for Fixed Broadband Wireless Access Systems. IEEE Standard for Local and metropolitan area networks. IEEE, June 2004.
- [3] Part 16: Air Interface for Fixed Broadband Wireless Access Systems, Amendment 2. IEEE Standard for Local and metropolitan area networks. IEEE, December 2005.
- [4] WiMAX End-to-End Network Systems Architecture, (Stage 2: Architecture Tenets, Reference Model and Reference Points). WiMAX Forum, March 2006.
- [5] D. Gray (edt). *Mobile WiMAX Part I: A Technical Overview and Performance Evaluation* WiMAX Forum, 2006.
- [6] E. Angori, A. Cimmino, M. Dinis, E. Guainella, J. Husko, E. Monteiro, and M. R. Spada, *WiMAX Extensions for Isolated Research Data Networks*, International Congress ANIPLA 2006: "Methodologies for Emerging Technologies In Automation", Rome, Italy, November 2006.
- [7] GEANT, European Research and Education Backbone. <http://www.geant.net>.
- [8] E. Guainella, E. Borcoci, M. Katz, P. Neves, M. Curado, F. Andreotti, and E. Angori, *WiMAX technology support for applications in environmental monitoring, fire prevention and telemedicine*, IEEE Mobile WiMAX Symposium, Orlando FL, USA, March 2007.
- [9] Network Simulator 2 (NS-2), <http://www.isi.edu/nsnam/ns/>.
- [10] NIST Seamless and Secure Mobility. <http://www.antd.nist.gov/seamlessandsecure.shtml>.

- [11] NDSL WiMAX Module for ns2 Simulator. <http://ndsl.csie.cgu.edu.tw/wimax/ns2.php>.
- [12] D2.3 System Specification. Project Deliverable. WEIRD Consortium, May 2007.
- [13] K. Knightson, N. Morita, and T. Towle, *NGN Architecture: Generic Principles, Functional Architecture, and Implementation*, IEEE Communications Magazine, pages 49-55, October 2005.
- [14] General Principles and General Reference Model for Next Generation Network. ITU-T Rec. Y.2011.
- [15] R. Rouil. The Network Simulator NS-2 NIST Add On. IEEE 802.16 model (MAC+PHY). NIST, September 2006.
- [16] D.2.2 System Scenarios, Business Models and System Requirements (version 2). Project Deliverable. WEIRD Consortium, February 2007.
- [17] J. Chen, C. Wang, F. Tsai, C. Chang, S. Liu, J. Guo, W. Lien, J. Sum, and C. Hung, *The Design and Implementation of WiMAX Module for NS-2 Simulator*, In ACM Valuetools 2006, Pisa, Italy, 2006. ACM.
- [18] J. Chen and W. Tan, *Predictive dynamic channel allocation scheme for improving power saving and mobility in BWA networks*, Mobile Networks and Applications, 12(1):15-30, 2007.
- [19] K. Fall (edt) and K. Varadhan (edt), The NS Manual (formerly ns Notes and Documentation). The VINT Project, May 2007.
- [20] L. Betancur, R. C. Hincapie, and R. Bustamante, *WiMAX channel: PHY model in network simulator 2*. In 2006 workshop on ns-2: the IP network simulator, ACM International Conference Proceeding Series, Pisa, Italy, October 2006. ACM.
- [21] "ns2mesh80216", IEEE 802.16 Wireless Mesh Networks in ns-2, University of Pisa, <http://info.iet.unipi.it/~cng/ns2mesh80216/>
- [22] C. Cicconetti, A. Erta, L. Lenzi, E. Mingozzi, *Performance evaluation of the mesh election procedure of IEEE 802.16/WiMAX*, Proceedings of the 10th ACM Symposium on Modeling, analysis, and simulation of wireless and mobile systems, Chania, Crete Island, Greece, 2007.
- [23] C. Cicconetti, I. F. Akyildiz, L. Lenzi, *Bandwidth Balancing in Multi-Channel IEEE 802.16 Wireless Mesh networks*, Proc. of the 26th Annual IEEE Conference on Computer Communications (INFOCOM 2007), Anchorage, USA, May 2007
- [24] A. Bacioccola, C. Cicconetti, G. Stea, *User-level Performance Evaluation of VoIP Using ns-2*, Workshop on Network Simulation, Tool, (NSTools) 2007, Nantes, France, October 22, 2007.
- [25] "ns2voip", User-level Performance Evaluation of VoIP Using ns-2, University of Pisa, <http://info.iet.unipi.it/~cng/ns2voip/>
- [26] C. Cicconetti, E. Mingozzi, G. Stea, *An Integrated Framework for Enabling Effective Data Collection and Statistical Analysis with ns2*, Workshop on ns-2: the IP network simulator (WNS2), Pisa, Italy, October 10, 2006.
- [27] "ns2measure", An Integrated Framework for Enabling Effective Data Collection and Statistical Analysis with ns2, <http://info.iet.unipi.it/~cng/ns2measure/>
- [28] OPNET Modeler, Opnet Technologies Inc., <http://www.opnet.com>



**Thomas Michael Bohnert** received his Dipl. Ing. degree in Computer Engineering from the University of Applied Sciences Mannheim, Mannheim, Germany in 2005. Thereafter he joined the University of Coimbra, Portugal from which he is

expected to receive his PhD in June 2008. After visiting Tampere University of Technology and VTT Technical Research Centre of Finland in Finland, and Beijing University of Posts and Telecommunications in China, between end 2006 and end of 2007, he joined Siemens Corporate Technology in January 2008. His research interests range from QoS control mechanisms in wired and wireless networks, in particular Admission Control and WiMAX QoS, over Carrier Ethernet Services, Future Internet Architectures to subjective VoIP Quality Assessment. He is founder and general chair of the IEEE Broadband Wireless Access Workshop ([www.bwaws.org](http://www.bwaws.org)) and is involved in various German and European projects like for example IST FP7 IP WEIRD, CELTIC/EURECA 100Get or ESF COST290. For the latter he serves as chair of the WiMAX Special Interest Group. Additionally he is involved in several international conferences like IEEE ICC, IEEE CCNC, WWIC, NEW2AN and CHINACOM. He is also Guest Editor for Elsevier Computer Communications and EURASIP Wireless Communications.



**Jakub Jakubiak** completed his B.S. studies in Telecommunications at AGH University of Science and Technology in Cracow, Poland, and the M.S. degree in Communications Engineering from Tampere University of Technology, Finland, in 2007. Since 2006 he holds a position of Research Assistant in Tampere University of Technology, Network and Protocols Group. His current research interests include wireless communications, with main focus on MANET and VANET networks (routing and MAC layer), WiMAX and wireless positioning.



**Marcos Katz** received the B.S. degree in Electrical Engineering from Universidad Nacional de Tucumán, Argentina in 1987, and the M.S. and Ph.D. degrees in Electrical Engineering from University of Oulu, Finland, in 1995 and 2002, respectively. He worked as a Research Engineer at Nokia Telecommunications from 1987 to 1995, designing analog circuits for high-speed PDH/SDH line interfaces. From 1995 to 2001 he was a Senior Research Engineer at Nokia Networks, Finland, where he developed multiple antenna techniques for several TDMA and CDMA research projects. In 2001–2002 he was a Research Scientist at the Centre for Wireless Communications, University of Oulu, Finland, where he concentrated on synchronization problems of CDMA networks. In years 2003–2005 Dr. Katz was the Principal Engineer at Samsung Electronics, Advanced Research Lab., Telecommunications R&D Center, Suwon, Korea. Since 2006 he works as a Chief Research Scientist at VTT, the Technical Research Centre of Finland. His current research interests include synchronization, multi-antenna techniques, cooperative and cognitive techniques, as well as optical communications, all aiming at future 4G wireless communication systems. In years 2006–2007 Dr. Katz served as the vice-chair of Working Group 5 (on short-range communications) for the Wireless World Research Forum (WWRF), and in year 2008 he was elected chair of that group.



**Yevgeni Koucheryavy** is an Associate Professor in the Department of Communications Engineering at the Tampere University of Technology, Finland. He received the M.Sc. degree (1997) from State University of Telecommunications, St.Petersburg, Russia, and the PhD degree (2004) from Tampere University of Technology, Tampere, Finland. Before joining the Tampere University of

Technology, he spent five years in industry with R&D LONIIS in St.Petersburg, Russia, where he held various technical and managerial positions. Yevgeni actively participates in IST projects, in particular he chairs COST 290 "Wi-QoS: Traffic and QoS Management in Wireless Multimedia Networks". Yevgeni has authored or co-authored over 60 papers in the field of advanced wired and wireless networking and teletraffic theory. He co-edited several proceedings books published in LNCS, Springer.

Yevgeni serves on TPC of a number of conferences and workshops; he also serves as an editor for several international journals. His current research interests include QoS provision techniques for wireless/mobile communications, network performance evaluation, short-range wireless communications, real-time services traffic optimization and cross-layer techniques.



**Edmundo Monteiro** is Associate Professor at the University of Coimbra, Portugal where he graduated in 1984 and got a PhD in Electrical Engineering – Computer Specialty, in 1995. His research interests are Computer Communications, Quality of Service, Mobility, Routing, Resilience and Security.

He is author of several publications including three books and over 100 papers in national and in international refereed books, journals

and conferences. He participated in many Portuguese and European research projects such as RARE, TERENA, COST263, FP5 NoE E-NET, FP6 NoE E-NEXT, COST 290, FP6 IP EuQoS, FP6 SSA OpenNet, FP6 IP WEIRD, and FP6 NoE CONTENT.

He is member of the Editorial Board of several journals and involved in the organization of many national and international conferences and workshops. He regularly acts as expert evaluator and reviewer for the European Commission and national organizations in the areas of Research Networks, Information Systems Technologies and Human Resources and Mobility.



**Eugen Borcoci** was is professor at University "Politehnica" of Bucharest (UPB), Electronics, Telecommunication and Information Technology Faculty. He graduated in Electronics and Telecommunications at Polytechnic Institute of Bucharest and then in Mathematics at University of Bucharest. He obtained his Ph.D degree at Polytechnic Institute of

Bucharest. His current interest is in telecommunication/computer systems and networks: architectures for fixed and mobile communications, signalling and protocols, QoS issues, multicast and multimedia communications. He has been UPB team leader in several European IST research projects: COP #62 Project (1995 - 1997); KIT project No. 977124 (1998-2000); IST-200-25137-MOICANE - (2001-2002), Network of Excellence EuroNGI IST 507613 (2003-2006), ([www.eurongi.org](http://www.eurongi.org)), ENTHRONE Project IST 507637, (2003-2005), WEIRD (2006-2008) ([www.ist-weird.eu](http://www.ist-weird.eu)). He has been member of several Int'l Conferences Technical Committees: PSTV'95, CFIP'96, 97, 99, IEEE ICT 2001, 2002, Eurasia ICT 2002, FORTE 2003, MoMM2004, NGI2005, AICT2005, 2006, NGI 2006, NGI 2007, NGI 2008, CTRQ 2008. He published 5 books, 4 textbooks and over 140, scientific or technical papers and research reports. He participated to more than 30 scientific or technical national projects.