

CCA-774

546.791:548.7

Original Scientific Paper

## On the Existence of the FCC Uranium\*

M. Tudja and Z. Ban

Institute »Ruđer Bošković«, 41000 Zagreb, Croatia, Yugoslavia

Received July 10, 1972

Diffusion studies in the system U—S, employing the couples U—US, U—US<sub>2</sub> and U—U<sub>3</sub>S<sub>5</sub> revealed the existence of new FCC phase with the composition ranging from approx. U<sub>20</sub>S to U<sub>8</sub>S. The lattice parameter of the phase as obtained in the diffusion couple is  $4.95 \pm 0.01$  Å. The same phase can be also obtained by the arc melting of the mixtures of U and US or U and S in the appropriate proportions, if followed by the heat treatment at 1900 °C during at least four hours. It is believed that this is a crystal structure modification of uranium stabilized by the addition of a small quantity of nonmetal atoms, where S and N play a mayor role. The same phase has been obtained through the addition of approximately 9 a/o of Se, Te, P, As, Sb, Bi, C and Si. Although the effect of the stabilization is not yet completely understood all samples contain a FCC phase and possess virtually the same lattice parameter as the phase containing sulphur. The experimental density amounts  $14.21 \text{ g cm}^{-3}$ . The calculated density is  $13.21 \text{ g cm}^{-3}$ .

### INTRODUCTION

During the last few years we have studied the solid state diffusion in the system U—S. The phase diagram U—S as proposed by E. D. Cater<sup>1</sup> is shown at Fig. 1. As seen, there are no other phases between uranium and the first

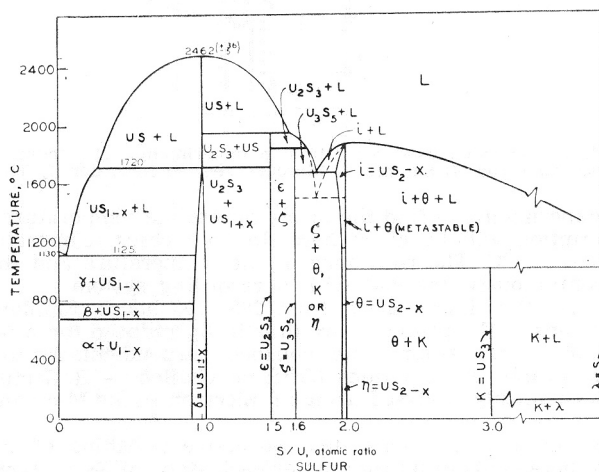

Fig. 1. Phase diagram U—S as proposed by Cater.

\* A Yugoslav Patent has been applied for under the Number 011-1489/1-1970.

binary phase in the system *i. e.* US. However, in the diffusion couples U—US, U—US<sub>2</sub> and U—U<sub>3</sub>S<sub>5</sub>, a distinct layer adjacent to uranium has been found. Electron probe microanalysis showed that a concentration of S is very low and ranges from U<sub>20</sub>S—U<sub>8</sub>S. These data ensured that we are in fact dealing with a new crystal form of uranium, stabilized by small additions of nonmetal. Later on, we found that an ample set of nonmetal elements is also able to produce the same effect to a limited degree. These phenomena are still under investigation.

#### EXPERIMENTAL

Uranium sulphides were prepared using the methods described by Picon and Flahaut<sup>2</sup>, Eastman and coworkers<sup>3,4</sup> and Shalek. US is the only material which can be cut, ground and polished and as such used for the preparation of the diffusion couples. The two other compounds *i. e.* US<sub>2</sub> and U<sub>2</sub>S<sub>5</sub> were pressed into rectangular rods at 12 t/cm<sup>2</sup> (5 × 5 × 25 mm) and then sintered in a high temperature furnace (Degussa, 300 mm Hg Ar) at 1400 °C with uranium fillings as a getter. After 5 hours, samples were slowly cooled in order to avoid cracking and cut in sections with a diamond saw, thus obtaining rectangular bodies having the dimensions of 5 × 5 × 4 mm. After being ground on emery papers, diamond paste (1/4 μ) was used for final polishing.

Two different methods were employed in order to ensure the contact between the reacting bodies:

- 1) the use of a stainless steel spring mounted in a molybdenum boat and
- 2) constant vertical load by means of stainless steel rod (225 g) (Fig. 2).

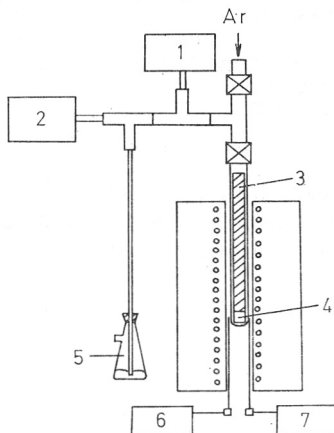

Fig. 2. A constant load apparatus used for diffusion experiments: 1) Vacuum meter, 2) Rotary pump, 3) Stainless-steel rod, 4) Sample, 5) Mercury seal, 6) Recorder, 7) Thermoregulator.

After many experiments to find the most appropriate temperatures and durations only a brief description will be given here. In both cases temperatures were kept at 800, 900 and 1000 ± 5 °C. The constancy of the temperature and the possible lack of current was continuously checked with a recording system.

In the first case the times varied from 288—700 hours. Employing a constant load method, durations of the process were drastically reduced (by a factor of 10—15).

Diffusion couples were ground and polished perpendicularly to the boundary, and used for micrographi examinations (Officine Galileo — Reflecting Microscope), samples were also chemically analysed using an Electron Probe Microanalyser (JEOL—3XA).

Couples were mechanically separated. Successive polishing of the contact surfaces was done in increments of 0.1 mm. After each step, an X-ray powder diffraction pattern was taken on a Philips 1010/30 Diffractometer (Ni-filtered CuK radiation).

Microhardness values were measured on the Microhardness Tester PMT-3 using a 100 p load during 15 sec. Both diagonals were measured, and an arithmetical

average used for the calculation. Microhardness data taken across the sample consisting of U and  $US_2$  are shown on Fig. 3. Densities were determined by a pycnometric method using decalin.

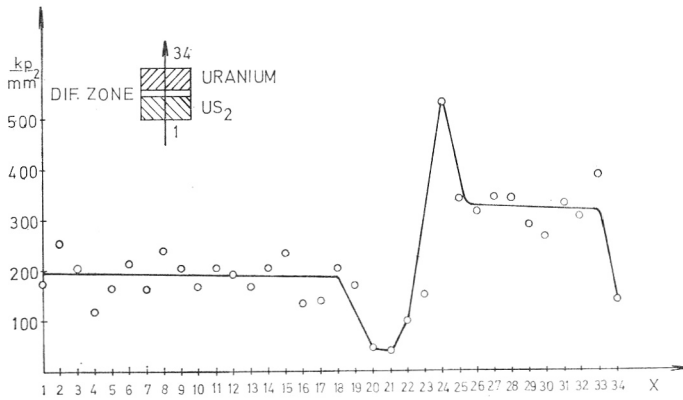

Fig. 3. Microhardness values as measured across the diffusion couple U —  $US_2$  ( $x = 0.23$  mm).

#### RESULTS AND DISCUSSION

Micrographs indicated the existence of a layer adjacent to uranium and strongly adhering to it (Figs. 4, 5, and 6). Electron Probe Microanalyser data showed that there is a plateau in the sulphur concentration, immediately after crossing the uranium side of the couple. A characteristic SK —  $\alpha$  picture is shown on Fig. 7. It has been noticed that the porous layer (gap) increases as the duration of the experiment becomes longer. This has been explained by the formation of a very brittle compound which besides uranium and sulphur also contains oxygen and nitrogen. It seems very probable, that this compound is in fact  $U_2(N,O)_2S$ , the structure of which has been described in the literature in different ways<sup>6,7</sup> Diffractometer data for this phase are given in Table I. The most interesting result obtained is that the layer adjacent to uranium actually represents a »new crystal form« of uranium. The lattice parameter

TABLE I

X-Ray Data for Hexagonal Phase of the General Composition  $U_2(N, O)_2S$

<i>h k l</i>	<i>d</i>	<i>I/I<sub>0</sub></i>
1 0 0	3.310	91
0 0 2	3.299	100
1 0 1	2.960	43
1 0 2	2.336	21
0 0 3	2.197	29
1 1 0	1.913	35
1 0 3	1.830	32
2 0 0	1.658	16
1 1 2	1.654	10
0 0 4	1.647	14
2 0 1	1.607	8
2 0 2	1.480	13
1 0 4	1.474	12
2 0 3	1.322	5

which is given in the abstract is the one determined from the samples appearing in the diffusion couples. The parameters of FCC—U, obtained from the direct preparations amount to  $4.89 \pm 0.01$  Å. (Table II). The phases in

TABLE II  
*Parameters of FCC—U Obtained from the Direct Preparations*

<i>h</i>	<i>k</i>	<i>l</i>	$d_o$ (diff. couple)	$d_o$ (direct prep.)	$I/I_o$
1	1	1	2.857	2.824	100
2	0	0	2.475	2.446	93
2	2	0	1.750	1.729	57
3	1	1	1.492	1.475	59
2	2	2	1.426	1.412	19
4	0	0	1.237	1.223	12
3	3	1	1.135	1.122	19
4	2	0	1.106	1.093	25
4	2	2	1.010	0.998	16
5	1	1	0.952	0.941	17

which one of the components is in great prevalence are quite common, as for example  $AB_{12}^{8-11}$  and  $AB_{13}^{12}$ , but in these cases new compounds having a distinct and often complicated crystal structures are formed. However, in the literature there are not very many examples where the second (metallic or nonmetallic) component, whether it is deliberately added or being present as an impurity, has an effect upon the crystal structure of the parent material<sup>13</sup>.

In connection with this the data on the existence of so called »monoxides« of Pa and U are reported in literature. In our opinion, these are data which have been misinterpreted. A plot of the lattice parameters of the FCC modifications of the elements from Th through Pu perfectly match with the idea of the 5f contraction as put forward by Zachariasen<sup>14</sup>, even if »monoxides« are taken into account. The same is valid for FCC—U when stabilized through the small additions of nonmetals (Fig. 8).

In order to prove the validity of our results as obtained through the diffusion studies, we also tried to prepare a pure FCC—U. By melting a set of mixtures of U and US, providing the proportions are within the overall composition varying from  $US_{0,02}$  to  $US_{0,40}$ , we obtained, typically, a mixture of FCC—U and  $\alpha$ -U. For the samples which were annealed at temperatures not higher than 1500 °C, the mutual quantitative ratio was not easy to interpret. However, recent experiments carried out at 1900 °C, for 4 hours, yielded a single phase FCC—U. Samples were usually contaminated with  $UO_2$ , but this is attributed to the imperfect experimental conditions. However even the samples containing some quantities of U and  $UO_2$  (inadequate purity of the atmosphere) can be purified using chemical methods. A short (3 min.) treatment with a mixture of  $HNO_3$  and  $C_2H_5OH$  (1:1) is sufficient to obtain a pure FCC—U phase. These data also suggest that the new phase is much more oxidation resistant than any one of the allotropic modifications of uranium. The results obtained using the DTA method (Fig. 9) proved the aforementioned observation.

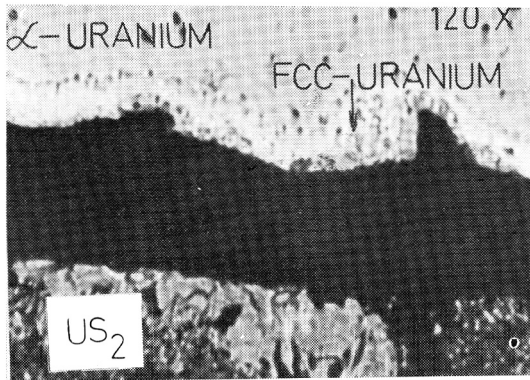
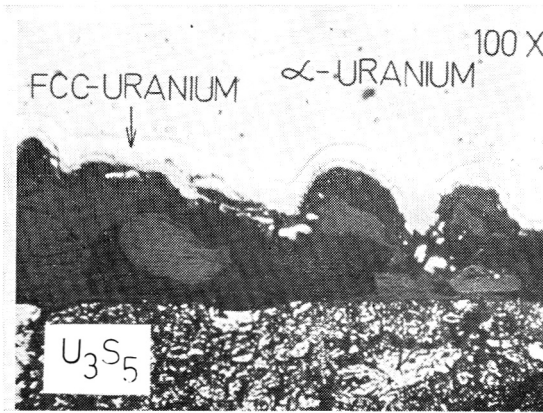
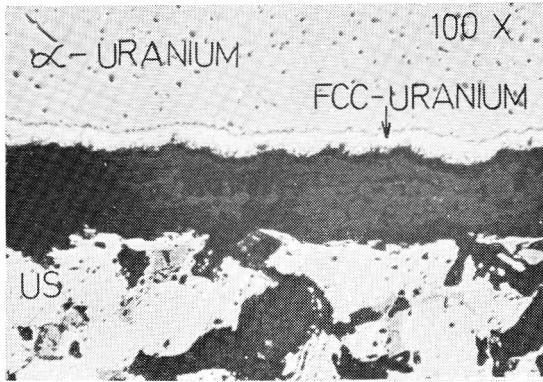

Fig. 4, 5, and 6. Micrographs of the diffusion couples U — US, U —  $U_3S_5$  and U —  $US_2$ .

[To face page 374]



Fig. 7. A characteristic X-ray picture ( $SK - \alpha$ ) obtained on the diffusion couple  $U - US_2$ .

[To face page 375]

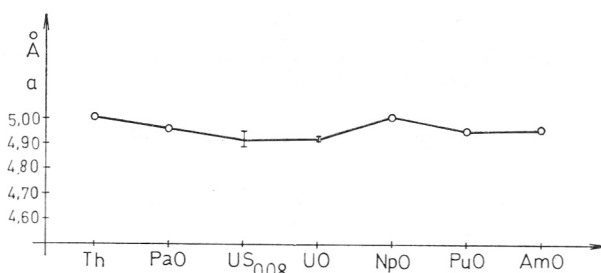

Fig. 8. Lattice parameters of pure FCC metals and the corresponding »monoxydes« in the actinide series.

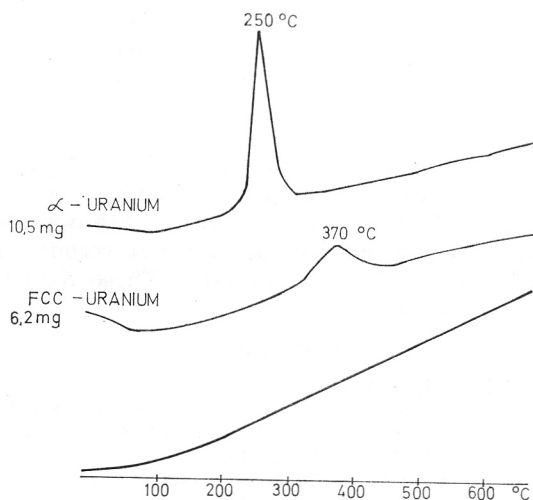

Fig. 9. DTA-curve for the oxydation of  $\alpha$ -U in comparison with the FCC-U (pure oxygen).

We also tried to prepare FCC-U in the following way: a button of U was placed near a small, previously weighted pellet of sulphur in an arc melting furnace.

The reaction between the two components proceeded very vigorously. The resulting product immediately exhibited a very high melting point. In this experiment we were unable to control the chemical composition exactly. Nevertheless, all samples, when subjected to the X-ray analysis, gave us the same result *i. e.* the mixture of FCC-U and a small quantity of  $\alpha$ -U. In both cases the density of the FCC-U is  $14.21 \text{ g cm}^{-3}$ . In order to find out whether some other elements produce the same effect (if added in a small quantity) the analogous experiments were carried out with P, As, Sb, Bi, Se, Te, C and Si. Providing that the atomic ratio is kept very low ( $\sim \text{UX}_{0.1}$ ) the same FCC-U phase appears with almost the identical lattice parameters (Table III). It must be mentioned that the proportion between  $\alpha$ -U and FCC-U differs considerably from one sample to another. After annealing was carried out at  $900 \text{ }^\circ\text{C}$  for 1170 hours, the quantity of the FCC-U in  $\text{UAs}_{0.1}$ ,  $\text{USb}_{0.1}$ , and  $\text{UBi}_{0.1}$ , was reduced while in  $\text{USi}_{0.1}$  completely disappeared. In the samples containing 9 a/o of Se, Te and P, only the intensity ratio of the diffraction lines  $I_{200}/I_{111}$  changes, suggesting the possible migration of nonmetal atoms among the octahedral and tetrahedral positions.

TABLE III

Lattice Parameters and Microhardness Values for a Set of Samples of FCC—U Stabilized with Different Elements

Sample	a Å	kp/mm <sup>2</sup>
USe <sub>0,1</sub>	4.88	677
UTe <sub>0,1</sub>	4.88	787
UP <sub>0,1</sub>	4.89	572
UAs <sub>0,1</sub>	4.89	254
USb <sub>0,1</sub>	4.89	855
UBi <sub>0,1</sub>	4.89	267
UC <sub>0,1</sub>	4.89	871
USi <sub>0,1</sub>	4.96	787

In conclusion, the phase diagrams U—S or U—S—X (X = nonmetal) have to be modified. The doubt that we are possibly dealing with a very thick layer of UO or UN (NaCl structure) which gives rise to the observed X-ray diffraction phenomena must be disregarded, because our recent neutron diffraction experiments proved the »working hypothesis«. These data will be published as a separate paper in the near future.

## REFERENCES

1. E. D. Cater, ANL — 6140 (1960).
2. M. Picon and J. Flahaut, *Bull. Soc. Chim. France* **140** (1958) 772.
3. E. D. Eastman, L. Brewer, L. A. Bromley, P. W. Gilles, and N. L. Lofgren, *J. Am. Chem. Soc.* **72** (1950) 4019.
4. E. D. Eastman, L. Brewer, L. A. Bromley, P. W. Gilles, and N. L. Lofgren, *J. Am. Chem. Soc.* **73** (1951) 3896.
5. P. D. Shalek, *J. Am. Chem. Soc.* **46** (1963) 155.
6. M. Allbutt and R. M. Dell, *J. Nucl. Mat.* **24** (1967) 1.
7. Z. Despotović and Z. Ban, *Croat. Chem. Acta* **41** (1969) 25.
8. J. Adam and J. B. Rich, *Acta Cryst.* **7** (1954) 813.
9. F. W. von Batchelder and R. F. Rauechle, *Acta Cryst.* **8** (1955) 691, **11** (1958) 122.
10. J. V. Florio, R. E. Rundle, and A. I. Snow, *Acta Cryst.* **5** (1952) 449.
11. J. A. Cohn and G. Katz, *14<sup>th</sup> Pittsburgh Diffraction Conference*, 1957.
12. O. J. C. Ruunals, *Acta Cryst.* **7** (1954) 222.
13. M. Pušelj, *M. Sc. Theses*, Faculty of Natural Sciences, University of Zagreb, Zagreb, 1971.
14. W. H. Zachariassen, *Acta Cryst.* **5** (1952) 1052.

## IZVOD

## O postojanju plošno centriranog urana

M. Tudja i Z. Ban

Tijekom studija difuzijskih fenomena u člancima U—US, U—US<sub>2</sub> i U—U<sub>3</sub>S<sub>5</sub> utvrđeno je postojanje plošno centrirane kristalne modifikacije urana koja je stabilizirana malom količinom nemetalnih komponenata (S i N). Ta se faza također može prirediti lučnim taljenjem urana, uz dodatak odgovarajuće količine sumpora, i termičkim tretiranjem pri 1900° kroz vrijeme od 4 sata. Gotovo isti utjecaj na nastajanje spomenute modifikacije imaju također i Se, Te, P, As, Sb, Bi, C i Si.

INSTITUT »RUĐER BOŠKOVIC«

41000 ZAGREB

Primjeno 10. srpnja 1972.