

## **Experience of Tyco & Antamina in the Lightning Performance and Reliability Improvement of 220 kV Transmission Lines in Peru**

**Jorge Luiz De Franco – Franco Engenharia / Tyco Electronics - Brazil**

**Craig Sutton - Tyco Electronics - UK**

**Carlos Riva - Tyco Electronics - Peru**

**Jorge Tuesta Rivera - Cia. Minera Antamina - Peru**

**Jose Francisco Montes - Cia. Minera Antamina - Peru**

**Wilson Alonzo - Cia. Minera Antamina - Peru**

**Mussolini Tarazona - Cia. Minera Antamina – Peru**

**Manuel Contreras - AB Technology - Peru**

### **SUMMARY**

The Antamina Mine is located in the Antamina valley in the Andes Mountains in the Ancash region of north-central Peru, approximately 270 kilometers north of Lima, Peru. Antamina Mine operations began in late 2001, with an estimated mine life of more than 20 years. The deposit is one of the largest copper-zinc ore bodies in the world.

Antamina Mine is electrically connected to five 220 kV transmission lines located in regions with isokeraunic levels from 15 to 90 thunderstorm days per year. In the period from 2002 to 2006, 80 non-schedule outages due to lightning which have affected the process productive have been observed in these lines. Antamina has too a 23 kV overhead shielded distribution ring network in which outages due to lightning have been also observed. In the middle of 2003 Antamina started to work in partnership with Tyco Electronics in order to evaluate the lightning performance of the distribution and transmission lines. With basis in these studies from January 2006 till June 2007, approximately 450 units of line arresters were installed along the distribution network and 265 gapless transmission line arresters (TLA) were installed along the sections of the two 220 kV transmission lines with poorer lightning performance. From October 2006 on only one outage due to lightning was recorded in these two lines, proving the effectiveness of this protection system.

This paper presents details about the transmission line lightning performance studies and evaluation carried out by Tyco Electronics and Antamina in this partnership project. Methods to select the arresters characteristics and to define the quantity and the optimized arresters location along the lines are presented. Field experience obtained in these two first years and the line performance / reliability of the system after the TLA application in comparison with the performance before the arresters' installation are presented and discussed.

### **KEYWORDS**

Transmission Line Arresters, Lightning performance, Lightning outages, Lightning Protection.

[franenge@terra.com.br](mailto:franenge@terra.com.br)

## INTRODUCTION

The Antamina Mine is located in the Antamina valley in the Andes Mountains in the Ancash region of north-central Peru. It is situated in the Western Cordillera range at an altitude of 4,300 m above the sea level, approximately 270 kilometers north of Lima, Peru.

The Antamina Mine, mill, and related support facilities are located at an elevation between 3500 m and 4500 m in the Andes, in the headwaters of two small streams which are tributaries of Rio Pucha, which is part of the upper Amazon Basin. The mean annual temperature of the area is about 3°C, with a minimum of -30°C. Mean annual precipitation is approximately 884 mm (recorded at 3,980 m) is mainly between October and May. Topography ranges from humid forest in the valleys and alpine fluvial tundra to very wet sub-alpine formations at higher levels.

Antamina Mine operations began in late 2001, with an estimated mine life of more than 20 years. The deposit is one of the largest copper-zinc ore bodies in the world. The mine is expected to produce an average of 675 million pounds of copper and 625 million pounds of zinc annually in its first 10 years. The mill has a rated capacity of 70,000 tones per day. A 302 km long slurry concentrate pipeline transports concentrates to the port facility at Huarney on the Pacific Ocean, where they are dewatered, stockpiled, and shipped by sea. The operations produce separate copper, zinc, lead and molybdenum concentrates. Antamina employs over 1,400 people directly and 3,500 indirectly.

Antamina Mine is electrically connected to five 220 kV transmission lines with a total length of approximately 566 km, which are located from 500 m up to 4,800 m above the sea level in regions with isokeraunic levels varying in the range from 15 to 90 thunderstorm days per year. In the period from 2002 to 2006 these lines presented 80 non-schedule outages due to lightning which have affected the process productive. Antamina has too an overhead shielded distribution ring network with length of approximately 14.4 km and outages due to lightning have been also observed on this line.

In the middle of 2003 Antamina started to work in partnership with Tyco Electronics in order to evaluate the lightning performance of the distribution and transmission lines. Studies have been done to evaluate the current lightning performance of the lines and to define the critical sections with a poor lightning performance. During the years of 2006 and 2007, approximately 450 units of line arresters with rated voltage of 27 kV were installed along the distribution network. The good results obtained after the arresters installations have encouraged Antamina to install arresters along the 220 kV transmission lines and in September / October of 2006, 135 units of gapless transmission line arresters with rated voltage of 192 kV were installed on the most critical sections of two lines that had previously recorded a poorer lightning performance. During the first thunderstorm period (October / May) after arresters' installation only one outage was recorded on one of these lines, in the section of the line not covered yet by line arresters. In the first semester of 2007, more 130 units of TLA with same electrical characteristics were installed along the critical sections of L-2254 and until February 2008 no outages were recorded on both lines, proving the effectiveness of this protection system.

## TRANSMISISON LINES CONNECTED WITH ANTAMINA SYSTEM

Antamina Mine is connected to five 220 kV transmission lines with a total length of approximately 566 km and 1280 steel towers. The lines are located from 300 m up to 4,800 m above the sea level in regions with isokeraunic levels varying in the range from 15 to 90 thunderstorm days per year. The main source of electrical energy for Antamina Mine comes from the Aguaytia's thermal headquarters through a 220 kV transmission line that connects it with the principal North-South energy system in Paramonga. This line connects a series of existent substations including the substation Tingo Maria to 73 km of the headquarters of Aguaytia (L-2251), the substation Vizcarra (L-2252) and the substation Paramonga Nueva (L-2253). The substation Paramonga Nueva is an important regional substation since it receives energy coming from the hydroelectric headquarters of Cahua and it provides a 66 kV transmission line to supply energy to the substations of Huacho and Huarney, in the port facilities of the Antamina's project.

The electric power supply for the operation of the Mine is provided by a 220 kV transmission line operating between the substation Vizcarra and the substation Yanacancha from Antamina (L-2255). The route of this transmission line rises in a mountainous land from 3,500 meters above the sea level in Huallanca to a maximum altitude of 4,600 m. This line has a length of 52.5 km with 131 steel towers. Antamina Mine is still connected with 220 kV transmission line “Paragsha – Vizcarra” (L-2254), whose operation was begun in September 2002. This line has a length of 121.1 km with 287 steel towers and the route of the line presents mountainous regions with altitude from 3,250 to 4,600 m above the sea level. Since September 2007 a new line L2262 (Vizcarra – Huallanca nueva ) has been taking part of the 220 kV system connected to Antamina. A schematic diagram of the lines connected to Antamina is shown in Figure 1. Table 1 shows information about the characteristics of the lines.

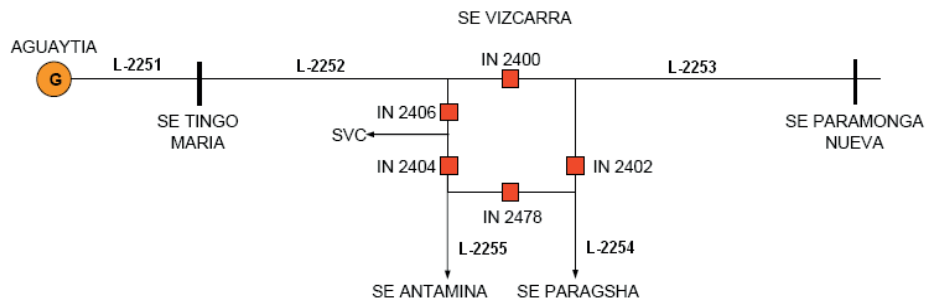

Figure 1 – Schematic diagram of the 220 kV transmission lines connected to Antamina

Table 1 – Parameters of the transmission lines

Transmission line	Length (km)	Number of towers	Altitude (m.a.s.l.)	Keraunic Level
L-2251	73.3	158	300 - 1,800	70 – 90
L-2252	173.3	366	700 - 4,100	40 – 60
L-2253	145.6	338	300 - 4,800	15 – 40
L-2254	121.1	287	3,250 – 4,600	60
L-2255	52.5	131	3,500 – 4,600	60

Antamina has too an internal 23 kV overhead shielded distribution ring network with length of approximately 14.4 km, that is for feeding of several load centers used for the mine’s production process. This line begins in main 220 / 23 kV substation and is located to an average altitude of 4,500 m above the sea level. Typical configuration of the line presents horizontal disposition in wood poles. However there are sections of the line with steel towers and triangular disposition, besides a smaller section with vertical disposition in wood poles. The whole line is shielded by an overhead ground wire type EHS with section of 38 mm<sup>2</sup> and the line insulation is basically composed by insulators strings type suspension with 4 insulators and by insulators type pin ANSI 56-4.

## TRANSMISSION LINES LIGHTNING PERFORMANCE AND GENERAL STUDIES TO EVALUATE THEIR IMPROVEMENT

From 2002 to 2006 Antamina has experimented 80 non-schedule outages due to lightning on five 220 kV transmission lines, which have affected the process productive with significant losses, in spite of more than 95% of these outages have transitory characteristics. Information about the number of outages due to lightning are shown in Table 2. From these outages, 33 outages (approximately 41%) have occurred along the transmission lines L-2254 and L-2255. Outages due to lightning have been also observed on the 23 kV distribution network. From January 2005 to January 2006, 11 outages were recorded carting total losses of 720 MW to the interruption in the production, with an average loss of 55.4 MW / month. Aiming the improvement of the lightning performance of the lines and its system reliability, Antamina started to develop in the middle of 2003 technical studies in partnership with Tyco Electronics. Studies have initially been done to evaluate the lightning performance of the distribution lines; to define the critical sections of the 220 kV transmission lines with a poor lightning performance; and to improve the earthing systems of the 23 kV and 220 kV lines.

Table 2 – Outages on 220 kV transmission lines due to lightning from 2002 – 2006

Year	L-2251	L-2252	L-2253	L-2254	L-2255
2002	4	6	0	4	1
2003	2	2	3	3	3
2004	3	6	3	8	2
2005	0	6	1	9	0
2006	4	2	5	3	0
Total	13	22	12	27	6
Outages / 100 km . year (Average from 02-06)	3,55	3,17	1,65	4,46	2,31

With basis in these studies, improvements were done in the earthing system of the line L-2255 and during the years of 2006 and 2007, approximately 450 units of class 2 gapless line arresters with rated voltage of 27 kV were installed along the 23 kV overhead shield distribution network. Figure 2 shows details of the line arresters installed on steel and wood structures for 23 kV.



Figure 2 – Class 2 arresters installed on 23 kV overhead shielded distribution network

The Antamina's production interrupted from January 2005 to January 2006 due to lightning outages on 23 kV lines before arresters' installation was 720 MW, with an average of 55.4 MW / month. After arrester's installation the losses from Feb. 06 till March 07 were reduced to 32 MW with an average of 2.5 MW / month. The good results obtained during the first thunderstorm period after the arresters installations in the distribution network have encouraged Antamina to install arresters along the 220 kV lines and, in the second stage of the study, more detailed lightning performance studies have been done to evaluate the lightning performance of the lines L-2254 and L-2255, which have shown approximately 41% of the total outages that have affected the process productive of the Mine.

The transmission line L-2254 has a total length of 121.1 km, 287 steel towers and typical configuration of the line presents four types of steel towers for single circuit with a triangular disposition of the conductors. Phase conductors are type FINCH ACSR 1113 MCM and the insulation is basically composed by insulators type composite and glass insulators with 18 insulators. Transmission line L-2255 has a total length of 52.5 km, 131 steel towers and typical configuration of the line presents three types of steel towers for single circuit. Phase conductors are type CURLEW ACSR Section of 591.2 mm<sup>2</sup> and the insulation is composed by glass insulators type Socket-Ball with 20 insulators for suspension and 21 for deadend strings. Both lines are shielded by two overhead ground wires type Extra High Strength (EHS) with diameter 9.52 mm and have the grounding systems composed by vertical electrodes and counterpoises. Lines L-2254 and L-2255 present approximately 88% and 92% of the towers with tower foot resistance values lower than 15 Ω. In spite of this from 2002 to 2006, 27 and 6 outages due to lightning affecting the Antamina system have been observed in the lines L-2254 and L-2255 respectively, carting average losses due to the interruption in the production of 45.6 MW / interruption for line L-2254 and 69.8 MW / interruption in the line L-2255.

Two different studies have been performed to evaluate the overhead lines lightning performance, using the procedures proposed by CIGRÉ [1] and IEEE Std.1243 [2]: (1) – lightning line performance estimate studies, in which transitory overvoltages across the insulators strings were obtained through computational simulations for different lightning current magnitudes and rise times. The main purpose of this study was to estimate the number of outages per hundred kilometres a year of the both lines due to backflashover, for the current configuration and for the different methods considered and proposed for the lightning performance improvement; (2) - studies to define the maximum energies absorbed by the line arresters, taking into account the lightning characteristics, the grounding system behaviour for fast transients and the probability of multiple strokes occurrence. Surge arresters models for fast transients were considered to get more reliable results in the energy studies.

Initially was evaluated the effect of the different towers types on the transmission line lightning performance. Towers which have presented the most critical behaviour were considered in the next stage of the study. Then transmission lines outages were evaluated for the critical towers, considering current configuration and the lightning performance improvements methods evaluated. These studies were done considering altitudes above the sea level from 3,200 m to 4,600 m. Starting from the results obtained in the studies and in the target outages desired for the lines, 135 units of class 2 gapless transmission line arresters (TLA) with rated voltage of 192 kV were installed in the second semester of 2006 on the most critical sections of the lines L-2254 and L-2255, considering the following criteria: (a) - for line L-2255, 45 TLA were installed on all phases of the 15 critical towers. These towers were chosen with basis on the lightning performance studies and in the historical of the critical points of the line, obtained through the failures analysis. Figure 3 shows TLA installed along the L-2255; (b) - for line L-2254, 90 TLA were installed on 49 towers along the sections of the line with poorer lightning performance. The locations of TLA were chosen with basis on the lightning performance studies, on the historical of the critical points of the line, and on the technical report from ISA Colombia [3]. Three TLA were installed on 19 towers; two TLA on 3 towers in the bottom and in the middle phases; and one TLA on 27 towers, being 16 in the bottom phase, 5 in the middle phase and 6 in the top phase (in this case for shielding failure protection). The installation procedure was witnessed by Interconexión Eléctrica ISA Perú S.A., owner of the line. During the first thunderstorm period (October / May) after arresters' installation no outages have been recorded on line L-2255 and only one outage was recorded on line L-2254 in the section not covered yet by line arresters.



Figure 3 – Class 2 TLA with rated voltage of 192 kV installed along 220 kV line

The rated voltage of 192 kV was selected to TLA taking into account the maximum temporary overvoltages for the lines and their durations considering the systems effectively earthed. Maximum energy obtained in the studies was below 650 kJ to a discharge current of 100 kA and tower foot resistance of 150  $\Omega$ . It corresponds to class 2 arresters. Due to the installation in the altitude from 3,250 m to 4,800 m above the sea level, combined with the contamination and environmental

characteristics of the region, the TLA were selected with a minimum creepage distance of 9,765 mm. It means 25 mm / kV, taking into account the correction factor by the altitude. Lightning impulse withstand voltage for the TLA housing is 1050 kV, while the lightning impulse protective level of TLA is 510 kV. It corresponds to a factor 1.29 between the lightning impulse withstand voltage of the housing (taking into account the correction factor due to the altitude) and the TLA protective level.

In May / June of 2007, more 130 units of TLA with same electrical characteristics were installed along the line L-2254. After this, the line L-2254 presents 220 TLA installed on 137 towers along its sections, being 80 towers with 1 TLA installed in the bottom phase, 31 towers with TLA installed in the bottom and in the middle phases, and 26 towers with TLA installed on all three phases.

From January till September 2007 Antamina has experienced four outages on transmission lines which have affected the Mine, being 2 outages in the line L-2251 and 2 in the line L-2252. Until February 2008 no outages were recorded on lines L-2254 / L-2255, proving the effectiveness of this protection system. Based on the initial results obtained in these two lines, Antamina and Tyco have started to work in the lightning performance evaluation of the lines L-2251, L-2252 and L-2253, in which there is an intention of installing TLA in this year in order to improve their lightning performance.

## CONCLUSIONS

- Antamina Mine is connected to five 220 kV lines that presented from 2002 to 2006 a number of 80 non-schedule outages due to lightning which have affected the productive process. From these, 33 outages (approximately 41%) have occurred along the lines L-2254 and L-2255.
- Aiming the improvement of the lightning performance and its system reliability, Antamina has developed in partnership with Tyco Electronics technical studies in order to evaluate the lightning performance of the lines. With basis in these studies, approximately 450 arresters with rated voltage of 27 kV were installed along the 23 kV distribution network and the good results obtained have encouraged Antamina to install arresters along the 220 kV lines.
- Lightning performance study has been done to evaluate the lines L-2254 and L-2255. Starting from the results obtained in the studies, 135 units of class 2 gapless line arresters with rated voltage of 192 kV were installed on the most critical sections of these lines, with significant improvement in their lightning performance. In the first semester of 2007, more 130 units of TLA were installed along the line L-2254, totaling 265 units of TLA installed on these two lines. No outages were recorded on lines L-2254 and L-2255, proving the effectiveness of this protection system.
- Based on the initial results obtained in the lines L-2254 / L-2255, Antamina and Tyco have started to work in the lightning performance evaluation of the lines L-2251, L-2252 and L-2253, in which there is an intention to improve their lightning performance.

## BIBLIOGRAPHY

- [1] CIGRÉ Working Group 33.01, "Guide to Procedures for Estimating the Lightning Performance of Transmission Lines", Cigre Publication n° 63, October 1991.
- [2] IEEE Std. 1243, "IEEE Guide for Improving the Lightning Performance of Transmission Lines", 1997.
- [3] Porras, L. F., "Análisis de fallas de la Línea Paragsha – Vizcarra 2003 – 2005", ISA Dirección de Gestión de Mantenimiento – Gestión Equipo de Líneas - DGM-2005-I-L-ET-162-V2, Colombia, Abril de 2006.
- [4] Montes, J. F., "Proyecto de Mejora de confiabilidad del Suministro Eléctrico de Antamina", Boletim O Forjando, número 2, Octubre 2006.
- [5] Córdova, J. C., "Estúdio de Mejora del comportamiento de la línea de 220 kV Aguaytía – Tingo Maria – Vizcarra ante descargas atmosféricas", Reporte EDEGEL, Volumen I, Julio 2002.
- [6] Reporte Antamina, "Línea de subtransmisión 23 kV de alimentación a Mina: Revisión de la coordinación de protecciones y aislamiento", Junio 2002.