

Diagnostic testing of dry-type transformer windings with induced voltage in combination with a sensitive partial discharge measurement minimizes the risk of unforeseen outages

ABSTRACT

Cast-resin power transformers are widely used in areas of high standards concerning fire hazards and environmental protection. The most common reason for failures of cast-resin transformers is the electric breakdown of the cast-resin insulation between turns or parts of the windings. In many cases, partial discharges (PD) occur before the breakdown happens. By testing the windings with induced voltage in combination with a sensitive PD measurement, the risk of unforeseen outages can be minimized. Methods for performing the induced voltage test on site with portable equipment and with digital PD instruments for reducing the disturbances are discussed based on case studies.

KEYWORDS

cast-resin transformer, induced voltage testing, partial discharge measurement

Diagnostic testing of cast-resin transformers

1. Introduction

The development of cast-resin transformers was initiated many decades ago because of the flammable nature of mineral oil and the risk of oil spillage with the related contamination of the ground. Since then, cast-resin transformer technologies have been well developed and are now widely used in applications where safety is of major importance, for example in buildings, in industrial applications, or for ecologically sensitive areas, such as ground water protection areas. The power and the nominal voltage of cast-resin transformers were increased

in the last few years. Nowadays, cast-resin transformers are built up to 72.5 kV and more than 60 MVA. They can also be equipped with on-load tap changers (OLTC).

Although cast-resin transformers are called “maintenance free”, periodic diagnostic measurements are requested more often – in particular, when outages would cause high follow-up costs. Some insurance providers offer cheaper tariffs when the risk of outages is minimized by periodic diagnostic measurements. For cast-resin transformers the diagnostic tools are limited. During manufacturing,

In order to determine the transformer condition directly on site, only a limited amount of test procedures can be used. Especially when it comes to assessing the insulation condition, common test methods which are typically performed on oil-filled transformers are not suitable. For instance, a dissolved gas in oil (DGA) analysis on cast-resin transformers is not applicable. Vice versa, the power/dissipation factor measurement on cast-resin transformers is highly affected by the ambient conditions. Therefore, partial discharge (PD) measurements yield the most valuable information on the insulation condition. On-site induced voltage test on cast-resin transformers, combined with PD measurements, is described in the following section.

2. Partial discharge measurement

For partial discharge (PD) measurements the frequency of the test voltage should be higher than the nominal frequency to avoid excessive excitation current during the test.

The most common reason for failures of cast-resin transformers is the electric breakdown of the cast-resin insulation between turns or parts of the windings. In many cases, partial discharges occur before the breakdown happens. By testing the windings with induced voltage in combination with a sensitive PD measurement, the risk of unforeseen breakdowns can be minimized.

For on-site PD tests on cast-resin transformers, a voltage source with adequate power is needed. The frequency of the output voltage should be higher than the nominal frequency of the transformer to avoid excessive magnetizing currents. In order to minimize the required power, the source should deliver an output voltage with variable frequency. The main inductance of the magnetic core, the capacitance of the high voltage winding and the coupling capacitor build a parallel resonance circuit. The frequency of the test voltage should be tuned to the resonance frequency of this parallel resonance circuit to reduce the needed power to the lowest level. If the resonance frequency is too high, an additional capacitor can be connected to the low voltage winding to reduce the frequency down to the upper limit of 500 Hz, according to IEC 60060-3 [2]. Figure 1 shows the setup with the CPC 100, a compact voltage source with a weight of 30 kg / 66 lbs.

The built-in amplifier can deliver up to 5 kVA at frequencies from 15 to 400 Hz. It has a “soft switching” design to avoid disturbances by the switching semi-conductors. With an additional matching transformer, the output voltage of the amplifier can be matched to the required excitation voltage of the transformer’s low voltage side. This universal matching transformer can deliver voltages from 50 V up to 400 V in steps of 50 V (at frequencies of 100 Hz or higher) and up to 800 V (at frequencies of 200 Hz or higher). During the factory acceptance

the following routine tests are performed according to IEC 60076-11 [1]:

- Turns ratio measurement
- Winding DC resistance measurement
- Measurement of voltage ratio and phase displacement
- Measurement of short-circuit impedance
- Load and no-load measurement
- Applied voltage test
- Induced AC withstand voltage test
- Partial discharge measurement ($U_m > 3.6$ kV, acceptance level 10 pC)

The most common cause of cast-resin transformer failures is the electric breakdown of the cast-resin insulation between turns or parts of the windings

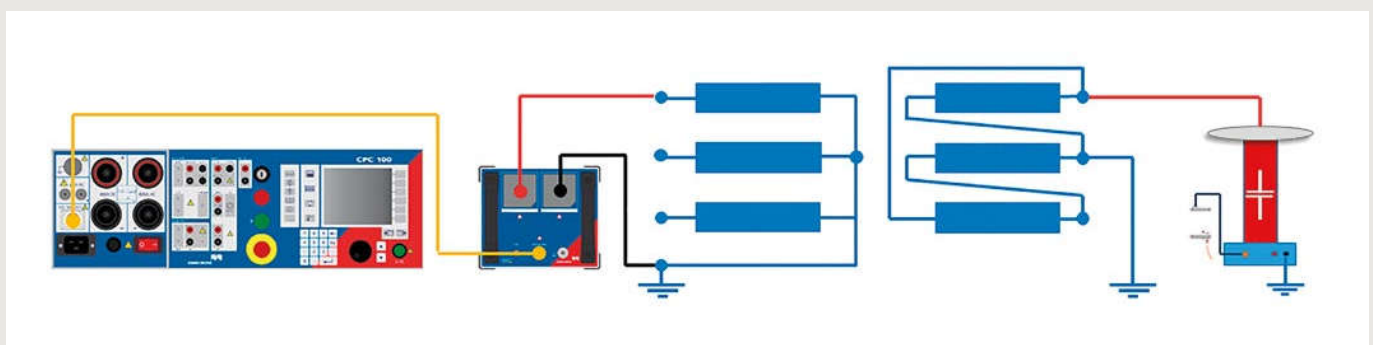

Figure 1. CPC 100 with matching transformers

Field experience has shown that voltages up to 130 % of the rated voltage are a good compromise to find partial discharge faults but not stress the coil too much

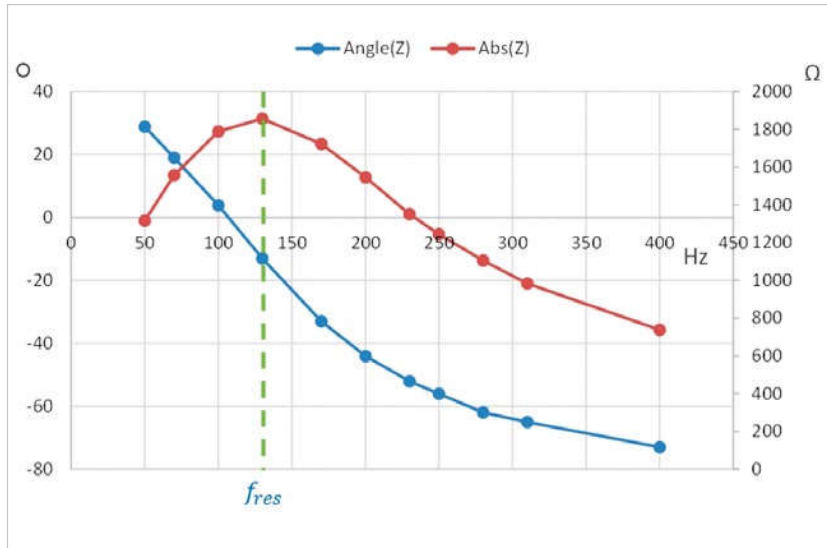

Figure 2. Impedance of the test circuit vs. frequency

test (FAT), three phase generators are used as voltage source. To check the integrity of the coils on site, it is sufficient to test each phase individually using a single-phase excitation. In the worst-case scenario a voltage rise above the rated voltage could lead to PD activity which remains active even after returning to nominal operation

voltage. Exceeding the nominal voltage during testing helps to identify such PD activity and to classify its severity. According to [1], during the FAT a pre-stress voltage is applied for 30 seconds. Afterwards, the test voltage is applied for another three minutes. On site, either these test cycle durations can be used or an

adapted cycle can be agreed upon. In order to avoid unwanted breakdowns of older transformers, high-voltage tests should only be performed with lower voltages than those used on new transformers in the factory. Field experience has shown that voltages up to 130 % of the rated voltage are a good compromise to find PD faults but not stress the coil too much.

Power transformers up to 3 MVA can be tested using a test power of 5 kVA. With the CPC 100, the impedance of the whole test circuit can be measured in amplitude and phase angle, Fig. 2. If the frequency is set to the maximum impedance (red curve), the required test power is minimized.

If the required power to energize the transformer exceeds the power output of one CPC 100, up to three devices can operate in parallel, Fig. 3. One CPC 100 works as a master; the other two work in a synchronous mode as slaves. Together they can deliver 15 kVA on three 230 V / 16 A plugs. With this portable test system, cast-resin transformers up to 25 MVA can be tested directly on site.

3. Electromagnetic interference from the surroundings

PD measurements outside of Faraday cages are troublesome due to electro-

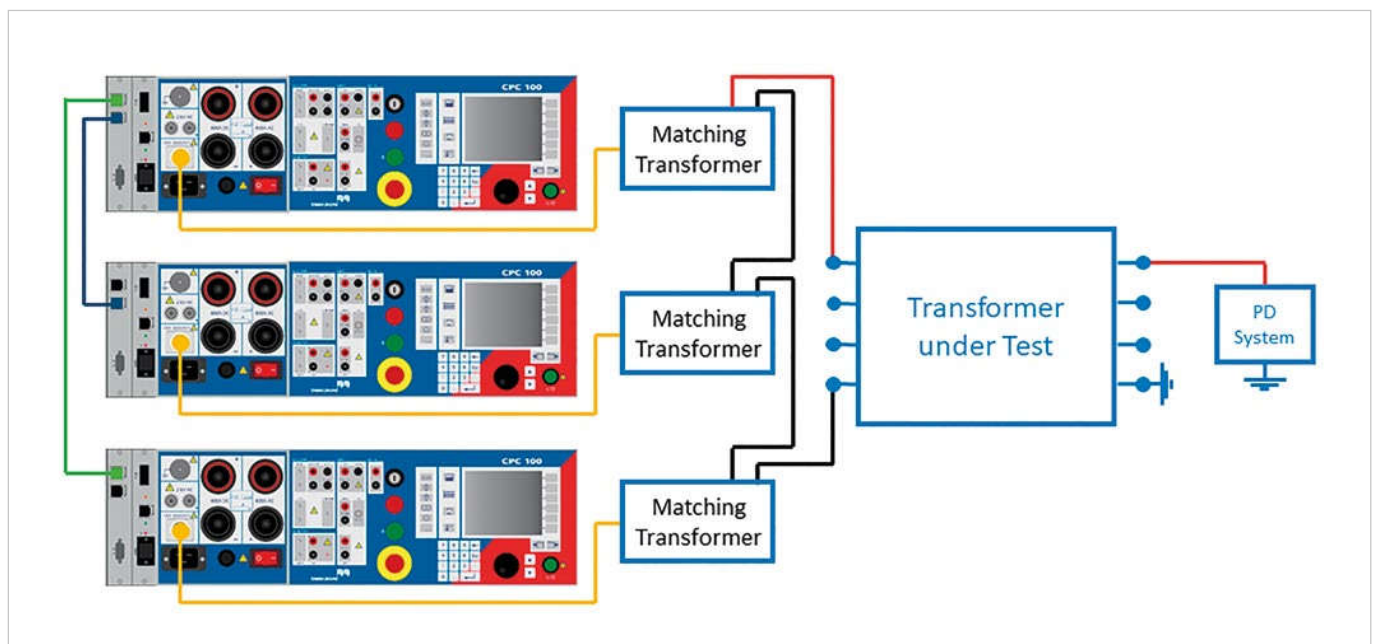

Figure 3. Test system for 15 kVA with three CPC 100

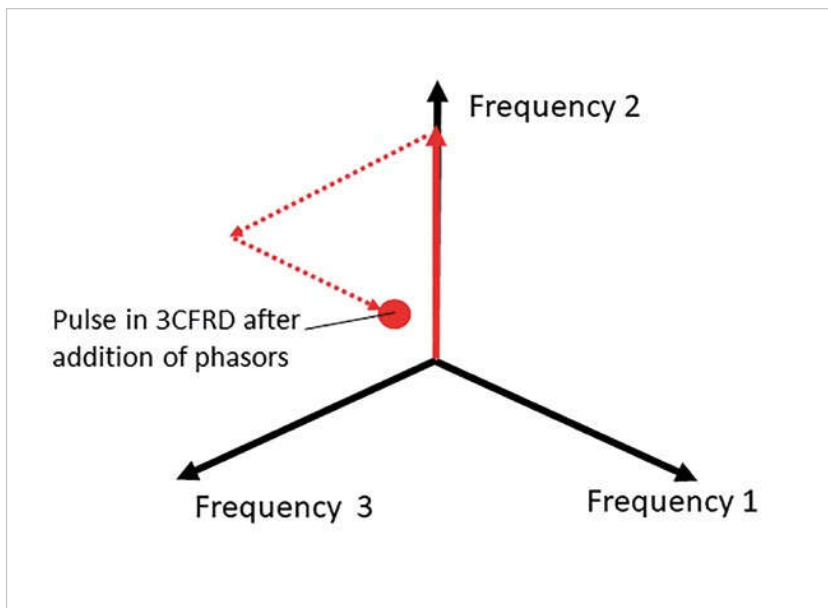

Figure 4. Single PD impulse entered in the 3CFRD diagram

When higher power is required, up to three CPC 100 devices can operate in parallel, allowing on-site PD testing of transformers up to 25 MVA

magnetic interference from the surroundings. Modern digital PD instruments provide special filtering methods which can reduce or even eliminate such noise problems.

One possibility to separate PD signals from ambient noise sources is to use the 3PARD or 3CFRD method [3]. Both

methods make use of a so-called star diagram which represents the relations between three measured signals. The 3PARD method uses three units to simultaneously pick up PD signals, while for the 3CFRD method, the digital PD instrument can measure PD impulses simultaneously at three different frequencies. For each frequency, a PD impulse is

evaluated. Afterwards, the discharge levels obtained at three frequencies, using a single instrument, are used to mark a corresponding point in a star diagram, Fig. 4.

Assuming that different PD and noise sources differ in their frequency spectrum, each source will show in a different cluster in the star diagram. By tuning the three frequency settings, an optimal separation of the individual clusters can be achieved. As a last step, each cluster is evaluated separately without interference from the remaining sources. This way a reliable evaluation of all PD sources can be achieved on site, even while strong disturbances are present, Fig. 5.

4. Case studies

4.1 Case 1

A PD measurement was performed on a 3.5 MVA cast-resin transformer with a rated voltage of 30 kV. Figure 6.1 shows the “Phase resolved PD” (PRPD) diagram at 40 kV. The noise is about 8 pC. The analysis with the 3CFRD is shown in Figure 6.2. The filtered signal, in Figure 6.3, shows a clear pattern of internal void discharges [4] with 6 pC, although the PDs are below noise level. The extinction voltage was above 36 kV, which is 20 % higher than the rated voltage. As a conclusion, during normal service no PD sources are active inside the transformer.

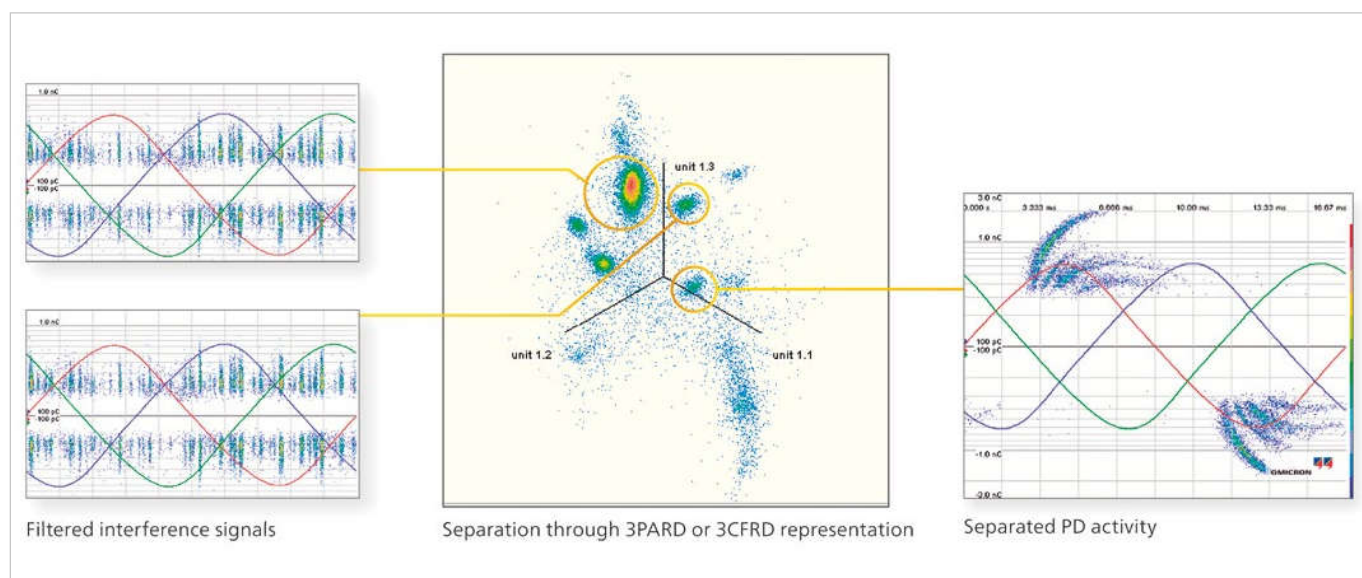

Figure 5. Separation through 3PARD or 3CFRD representation

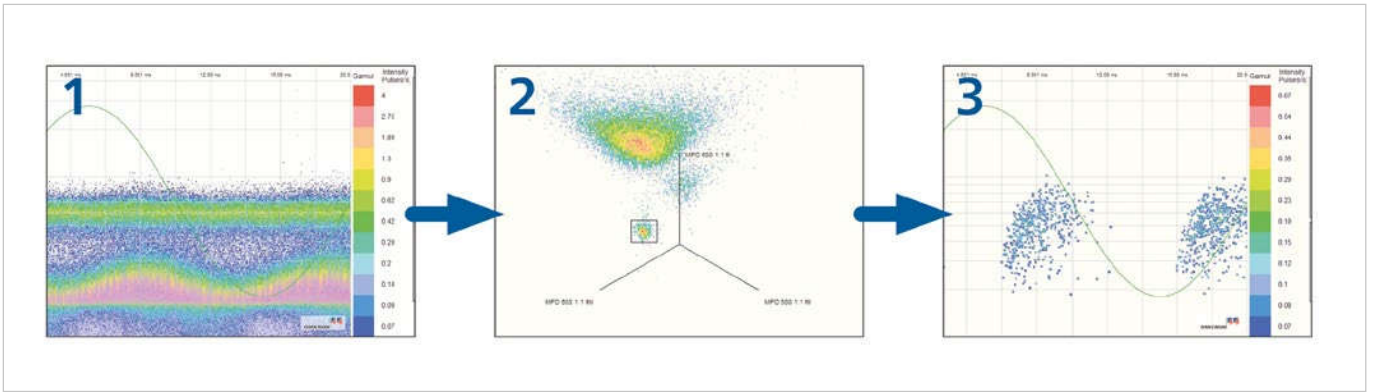

Figure 6. (1) PRPD without 3CFRD filtering with interference; (2) star diagram with noise (top cluster) and PD cluster (marked); (3) PD pattern of voids with 3CFRD filtering



Figure 7. Breakdown fault on cast-resin transformer

4.2 Case 2

After a single-phase failure of a 2.5 MVA cast-resin transformer, Fig. 7, it was investigated whether the remaining two windings had also been damaged. A partial discharge measurement on both outer windings was undertaken with 130 % of the rated voltage to prove that these windings were free of PD. No PD could be detected above the noise level of 15 pC. It was then decided to replace the faulty winding and to put the transformer back into service.

Figure 8 shows the PD measurement results of phase B after installing the new winding on the transformer. During the on-site PD measurement interference signals of 17 pC were measured. The only visible cluster was related to the ambient noise. In this case, the so-called inverse 3CFRD was used. The only visible cluster was selected and filtered out, Fig. 8.2. Instead of showing the impulses related to this cluster, all

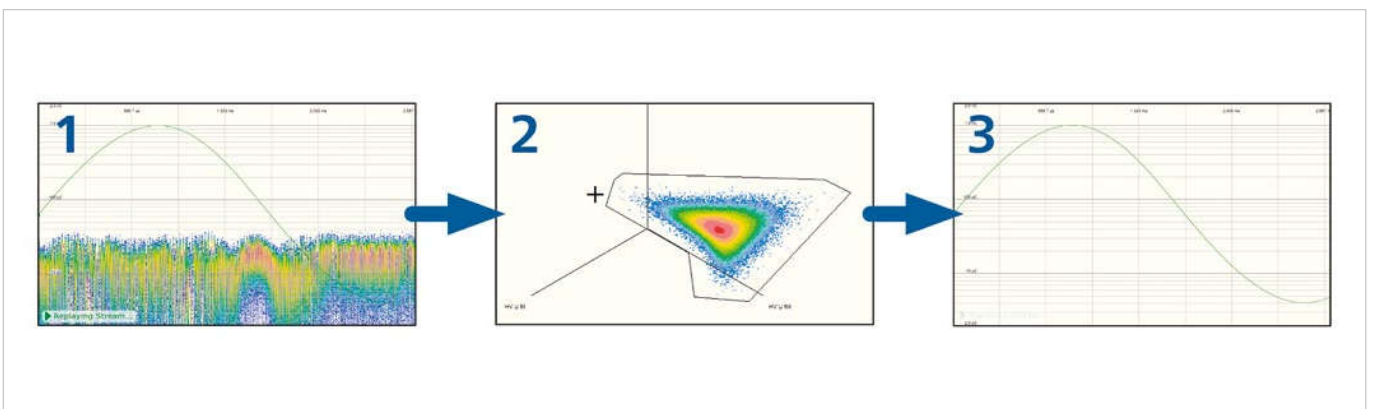

Figure 8. (1) Unfiltered PD measurement; (2) 3CFRD cluster selection; (3) PRPD with inverse 3CFRD filtering

remaining pulses outside this cluster are shown. Figure 8.3 shows the inverse principle of 3CFRD filtering while the noise cluster was selected. It can be seen that no other impulses are visible, which leads to the conclusion that the new installed coil has no measurable PD. The inverse 3CFRD filtering should be performed carefully in order to avoid filtering out any PD signals.

4.3 Case 3

In an industrial 20 kV grid, all cables are equipped with HF PD couplers at the terminations to make biannual routine monitoring measurements of the whole grid, including the cables and the transformers. During a routine monitoring test, partial discharges were detected on one of the cable terminations. To find out if the PDs are in the cable or in the connected transformer, an off-line PD measurement was carried through. The cable did not show any PD, but the transformer did. Figure 9 shows the setup of a PD measurement on the transformer under test. On all phases PDs were detected and showed typical patterns of internal voids with discharge levels up to 101 pC, Fig. 10. The inception voltage was found to be $1.0 \times U_n$, while the extinction voltage was below nominal voltage ($0.6 \times U_n$) on all three phases. This means that the transformer has continuous partial discharges during operation and should be replaced. As a consequence, the operator decided to replace the transformer completely.

4.4 Case 4

PD measurements were done on a 30 kV / 6 kV / 17 MVA cast-resin transformer. Figure 11 shows the applied test setup. In order to energize the 6 kV side of the transformer, an additional step-up transformer was needed. The required 10 kW power to create excitation of one phase of both transformers was delivered by three synchronized CPC 100s. The test voltage of $1.3 \times U_n$ was applied for 60 seconds as agreed upon on site. Figure 12 shows the PD measurement result of phase B, which shows no PD impulses above the noise level of 8 pC.

Conclusions

On-site induced voltage testing in combination with partial discharge measure-



Figure 9. PD measurement setup on a 20 kV / 2 MVA cast-resin transformer

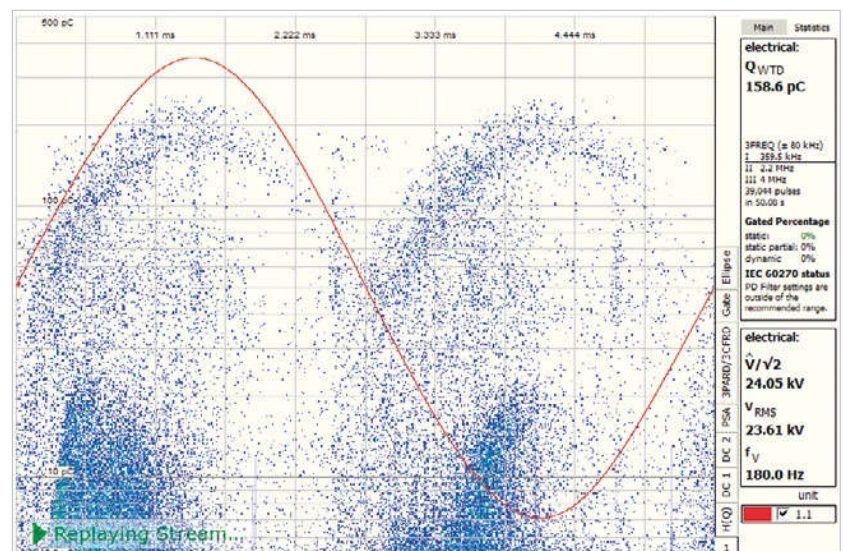

Figure 10. PD measurement results

Modern digital PD instruments separate signals from ambient noise sources using 3PARD or 3CFRD methods

ments is a powerful tool to assess the insulation condition of cast-resin transformers.

In order to conduct the measurement, a voltage source with variable frequen-

cy is needed. Depending on the power consumption, up to three OMICRON CPC 100 units can be synchronized. By doing so, the output power can be increased up to 15 kVA. Depending on the transformer design and the required

The 3CFRD method evaluates discharge levels obtained with three different frequency settings and uses star diagram to identify clusters which separate PD and noise sources

test voltage, power transformers up to 25 MVA can be measured using this synchronization functionality. Nevertheless, it is still a flexible and portable solution for on-site testing, as all required components weigh less than 30 kg / 66 lbs each.

Usually, different types of noise sources are present during on-site measurements. Thus, the digital PD instrument offers several ways to cope with high disturbances. One proven tool for filtering noise and separating different PD sources is the so-called 3CFRD method. Evaluating the discharge levels obtained with three different frequency settings, the influence of noise sources can be minimized and each PD source can be evaluated individually.

Bibliography

- [1] IEC 60076-11, *Power transformers – Part 11: Dry-type transformers*, International Electrotechnical Commission, Geneva, 2004
- [2] IEC 60060-3, *High-voltage test techniques*, Part 3: Definitions and requirements for on-site testing, International Electrotechnical Commission, Geneva, 2006
- [3] K. Rethmeier, A. Obralic, A. Kraetge, M. Krüger, W. Kalkner, R. Plath, *Improved Noise Suppression by real-time pulse-waveform analysis of PD pulses and pulse-shaped disturbances*, International symposium on high voltage engineering (ISH), Cape Town, 2009
- [4] Cigré 676, *Partial Discharges in Transformers*, Working Group D1.29, Cigré 2017

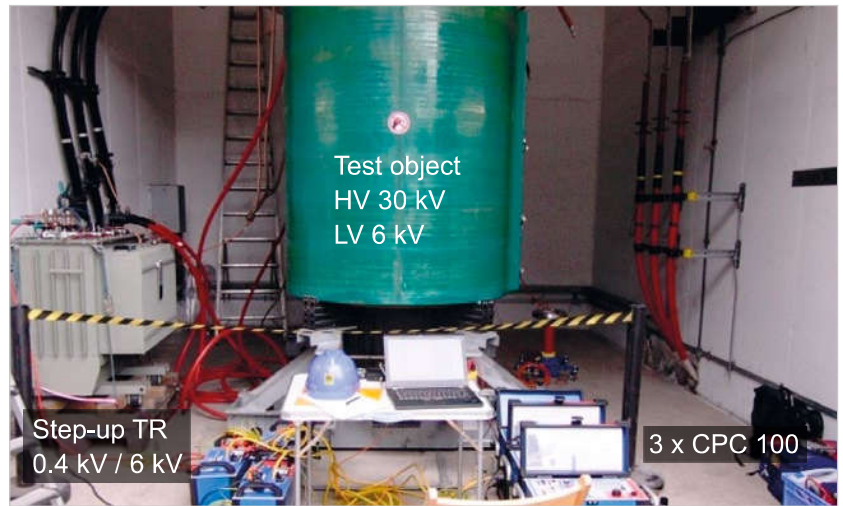

Figure 11. PD measurement on a 17 MVA cast-resin transformer using three CPC 100

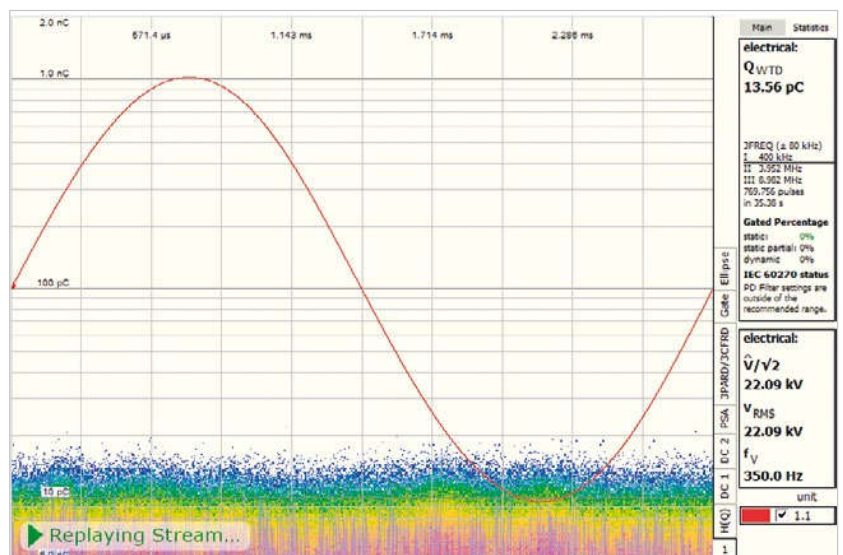

Figure 12. PD measurement results on phase B

Authors



Michael Krüger is principal engineer with OMICRON electronics GmbH in Klaus, Austria. He studied electrical engineering at the Technical University of Aachen (RWTH) and the University of Kaiserslautern (Germany) and graduated in 1976 (Dipl.-Ing.). In 1990 he received the Dr. (PhD) degree from the Technical University of Vienna. Michael Krüger has more than 35 years of experience in high voltage engineering and insulation diagnosis on GIS, instrument transformers, cables, power transformers and rotating machines. He has published many papers about electrical measurements on different assets and holds 15 patents. He is a member of VDE, Cigré and IEEE and participates in several working groups for OEVE, IEC and Cigré.



Christoph Engelen holds an MSc degree in electrical engineering from the RWTH Aachen University in Germany. After he graduated in 2013, he started his professional career as an application engineer at OMICRON electronics where he focused on transformer diagnosis. Since 2017 he is part of the product management and specializes in the business development of cast-resin transformer testing.