

## Medium and Low Voltage Cable Measurements - TD, PD, LIRA

**Josip Čeović**

Elmont d.o.o Krško  
Cesta Krških Žrtev 135e, 8270 Krško, Slovenia  
[josip.ceovic@elmont-kk.si](mailto:josip.ceovic@elmont-kk.si)

**Matko Širola**

Elmont d.o.o Krško  
Cesta Krških Žrtev 135e, 8270 Krško, Slovenia  
[matko.sirola@elmont-kk.si](mailto:matko.sirola@elmont-kk.si)

### ABSTRACT

Elmont d.o.o. Krško – We have spread our main scope of the services from electrical maintenance, modifications implementations and quality control to cable testing area. The main reason for expanding our scope was to support Nuclear Power Plant Krško Cable Aging Management program and the world trend of LTE (Life Time Extension) in power plants.

Scope of work – We are identifying potential downgraded conditions for safety and operational important cables in special areas (heat, water, radiation). Our main scope is visual control, and testing with analysis.

For **low voltage** cables the main testing method is Line Resonance Analysis (LIRA). LIRA technology is based on the transmission line theory, through the estimation and analysis of the complex line impedance as a function of the applied signal frequency. We can monitor the global, progressive degradation of the cable insulation due to harsh environment conditions (high temperature, humidity, radiation) and detect local degradation of the insulation material due to mechanical impacts or local abnormal environmental conditions.

For **medium voltage** cables we are using new methods with a power generator that uses Very Low Frequency – 0,1Hz (VLF). The main reason for this is that the measurement unit needs 500 times less energy than the unit which uses 50Hz frequency ( $50/0,1=500$ ). With this power source we are performing dielectric loss measurements – Tan delta (TD) and Partial discharge measurements (PD).

TD measurements show the severity of Water treeing in the measured cable. Water trees mainly come from moisture and are therefore present in cables that lie in manholes filled with water or they submerged in any other way.

PD measurements show the severity of voids or other types of defects in cable insulation. These defects can arise during the manufacturing of the cable or they can arise during the installation of the cable or from an accident with the cable during the operational time.

**Keywords:** *Line Resonance Analysis, Tan Delta, Partial Discharge, Water Treeing*

# 1 INTRODUCTION

Cable integrity is vital to the safe and efficient operation of a nuclear power plant or facility, especially as a plant enters into long-term operation of 40 years or more. Despite their importance, cables typically receive little attention – they are considered passive, long-lived components that are very reliable. However, cable failures have caused plant shutdowns, safety concerns and loss of revenue. Performance and safety concerns demand proactive and preventative approaches to cable integrity and reliability. A cable health and aging management program anticipates and addresses cable aging issues, helps reduce maintenance costs, avoids unscheduled shutdowns and repairs, incorporates industry best practices and addresses regulatory requirements.

Field testing (such as tan delta, partial discharge, LIRA) provide a basis for establishing appropriate maintenance.

For low voltage cables our main testing method is Line Resonance Analysis (LIRA). The LIRA technology was developed by the Institute for energy Technology (IFE) in Halden, Norway in the early 2000's. It was initiated by the need of non-destructive test and condition assessment methods for cables in nuclear power plants. Many cable condition assessment technologies in the market today are potential destructive, and cannot be regarded as an alternative test method for cables where cable destruction leads to time consuming and cost driving maintenance operations. Other technologies are non-destructive, but provide too little information and security related to the continued operation of the relevant cable.

AC power frequency test sets are relatively large, heavy, and expensive and they require large impractical amounts of power in the field to energize cables. The reason why cables require so much power to energize at power frequency is because they are essentially seen as “capacitors” to an AC power source. The longer the cable, the larger the capacitance becomes. The cable capacitance is mainly dependent upon the geometry and dielectric constant of the insulation. For most cables, a rough guide for a cable capacitance is 300pF per meter of cable. The power required to energize, even relatively short sections of cable, at relatively low test voltages, will soon overload a standard AC power supply. The only practical component that can be adjusted to reduce the power requirement is that of the applied frequency. The reactive power required by an applied test voltage level at 0.1Hz is 500 times lower than that at 50Hz. This was originally the main driving force behind the development and use of VLF for testing capacitive loads such as cables, generators etc.

For medium voltage cables we are using high voltage system HVA28 from *b2 electronic GmbH* company with a power generator that uses Very Low Frequency (VLF) – 0,01- 0,1Hz .

## 2 LINE RESONANCE ANALYSIS PROCEDURE

### 2.1 LIRA basic

The LIRA (Line Resonance Analysis) Technology is a cable condition assessment, cable fault location and cable aging management system that works in frequency domain through advanced proprietary algorithms. LIRA is based on the transmission line theory, and calculates and analyze the complex line impedance as a function of the applied signal for a wide frequency band. It detects and locate changes in the cable impedance and makes it possible to perform fault location and cable condition monitoring on I&C, low, medium and high voltage cables even in inaccessible challenging environments. The applied frequency band is a 5V signal, and is harmless to the cable. LIRA will detect and locate local degradations in the cable, which is specific to certain sections of the cable and caused by mechanical stress and damages, or by heat-induced oxidation and radiation. It will also detect global degradation in the cable, which is applicable for the entire cable, and is caused by general aging, influenced by external and internal environmental conditions.

LIRA relies on the correlation between insulation's condition and its dielectric constant (mainly capacitance) and calculates the impedance spectrum (amplitude and phase) as a function of the applied signal over a wide frequency band. The capacitance of a cable changes as a function of changes in the cables permittivity and changes in the cable's radius, as shown in Figure 1.

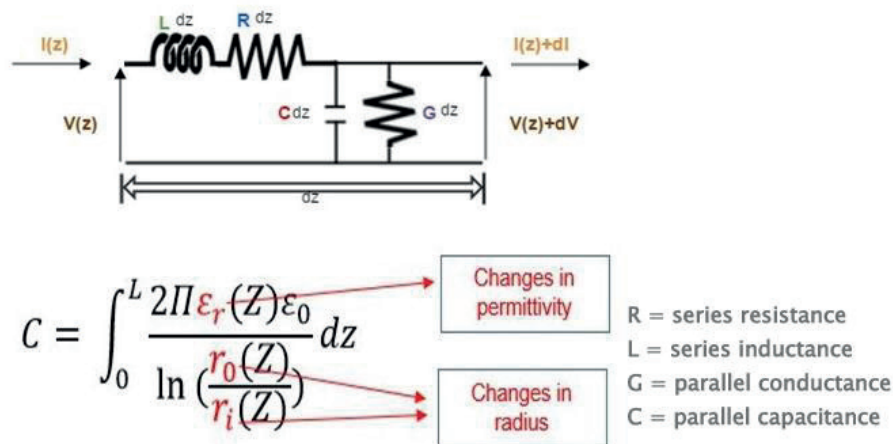

Figure 1: Schematic representation of transmission line model

## 2.2 LIRA Measurements

For a complete cable analysis, LIRA provides the following tools:

- *Input impedance spectrum check (Imp)* - The spectrum is used to adjust the used bandwidth so that the high frequency part of the spectrum still contains useful information, or, in other words, it does not completely fade out because of the cable attenuation. Figure 2. represents impedance spectrum of 47 m long EPR insulation based test cable.

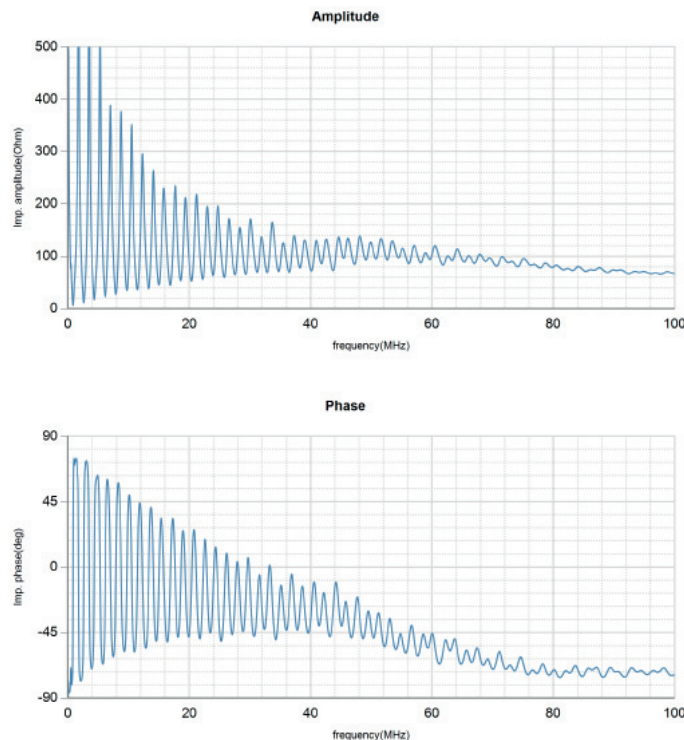
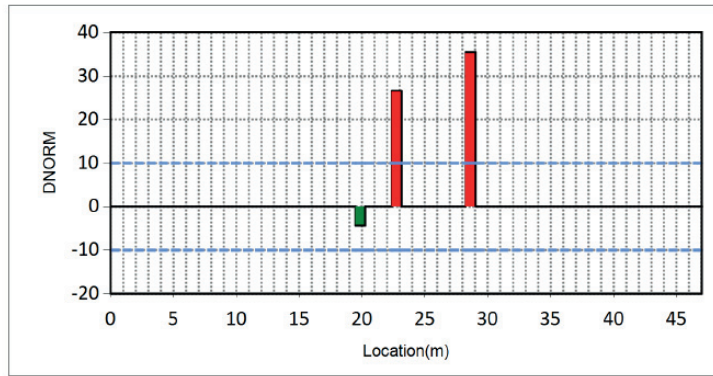

Figure 2: EPR insulation based test cable impedance spectrum

- *DNORM view (DNORM)* - This is the severity assessment tool in LIRA. Any feature, visible in the signature, is tagged as green, orange or red, according to the estimated severity. The DNORM tab shows a normalized graphical interpretation of the finding along the measured cables length, without the start and end terminations shown. Bars are shown in red when they exceed the double of the threshold (default: 10), orange from 80% of the threshold to the red threshold, otherwise in green. Our test cable isolation was cut at approximately 20m, what is visible as green bar ( Figure 3.). Cable also had two splices (22m and 28m ) visible as red bars in Figure 3.



Event	Loc(m)	Peak(dB)	Direction	DNorm	Severity
Event 1	19.5	1.46	Down	4.38	Green
Event 2	22.4	8.89	Up	26.65	Red
Event 3	28.2	11.85	Up	35.52	Red

Figure 3: DNORM view of test cable

- *Global parameters* - The estimated cable parameters (Figure 4.) C (dielectric capacitance), L (cable inductance), att (cable attenuation), Z0 (characteristic impedance) and VR (phase velocity ratio) can be compared to the expected values to increase the measurement reliability.

Test results & key parameters	
Max frequency band(MHz)	99.99
Bandwidth utilization(%)	100
Cable length(m)	47.05
Velocity ratio	0.563
Calculating frequency(Hz)	1301068
Attenuation(db/Km)	19.3
Capacitance(pF/m)	55.6
Char.Impedance(O)	107.3
BTS	0.0
DeltaG	0.0

Figure 4: Test cable global parameters

- *Cable trend graphs* - The frequency trends (Figure 5.) are provided for the following parameters: Characteristic impedance (Z0), Velocity Ratio (VR), Attenuation Resistance, Dielectric capacitance, Cable inductance.

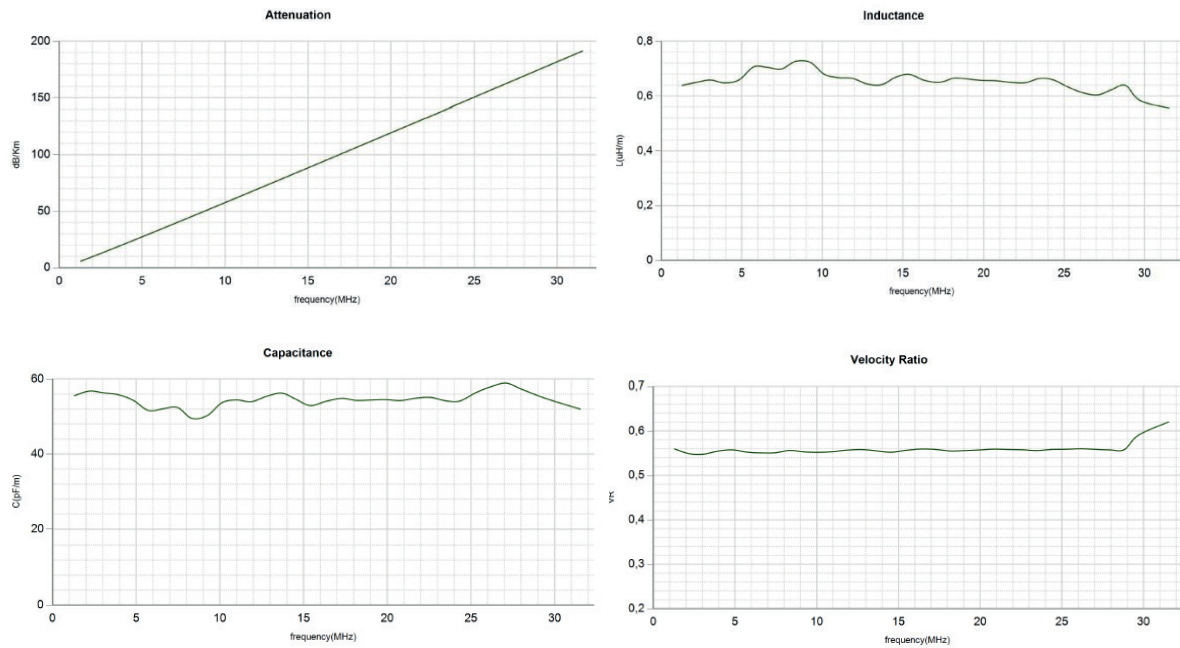

Figure 5: Test Cable trend graphs

- Termination assessment (BTS)* - is based on the Fourier transform of the cable impedance spectrum, at the maximum bandwidth allowed by the applied maximum frequency. While the output of the Fourier analysis for the LIRA signature is a power spectrum, for the BTS analysis the complex output is preserved. The ratio between the difference of the imaginary and real component of the transformation function (also called the BTS signature function) has a significant diagnostic value and it is bounded between  $+\sqrt{2}$  and  $-\sqrt{2}$ . Figure 6a. shows resulting BTS graph of our test cable with a good termination. The largest peak in Figure 6a. is the cable termination. Any change in the insulation properties at or near the termination (inside the shadow area), would cause an undershoot below zero. In another measurement test cable had bad termination (moisture). Figure 6b. shows degraded cable termination with characteristic undershoot.

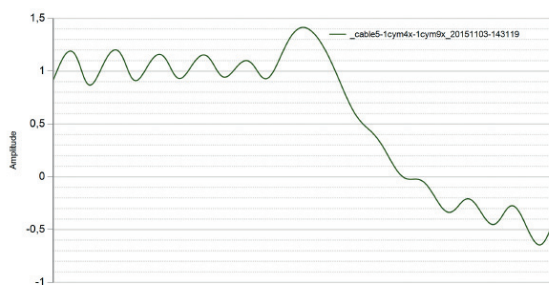

Figure 6a: BTS graph for a normal termination condition

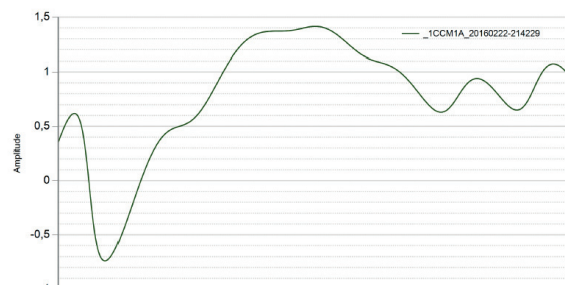

Figure 6b: BTS graph for degraded termination condition

### 3 VLF MEASUREMENTS

### 3.1 Tan Delta (TD) Basic

Tan Delta ( Loss Angle or Dissipation Factor) testing, is a diagnostic method of testing cables to determine the quality of the cable insulation. This is done to try to predict the remaining life expectancy and in order to prioritize cable replacement. If the insulation of a cable is free from defects, like water trees, electrical trees, moisture and air pockets, etc., the cable approaches the properties of a perfect capacitor. It is very similar to a parallel plate capacitor with the conductor and the neutral being the two plates separated by the insulation material.

In a perfect capacitor, the voltage and current are phase shifted 90 degrees and the current through the insulation is capacitive. If there are impurities in the insulation, like those mentioned above, the resistance of the insulation decreases, resulting in an increase in resistive current through the insulation. The current and voltage will no longer be shifted 90 degrees. The extent to which the phase shift is less than 90 degrees is indicative of the level of insulation contamination, hence quality/reliability. This “Loss Angle” is measured and analyzed.

Tangent delta can be calculated according to:

$$\tan\delta = \frac{I_R}{I_c} = \frac{\frac{V}{R}}{V \times 2\pi f C} = \frac{1}{2\pi f C R} \quad (1)$$

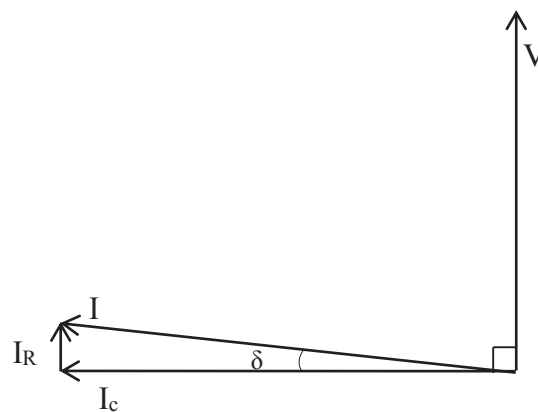

Figure 7: Tan Delta

Dielectric losses are mainly dominated by the conductive losses that occur in the insulation material. In simple terms, the insulation resistance is inversely proportional to Tan Delta.

### 3.2 TD Measurements

For our measurements we have selected a powerful unit – high voltage (HV) source with integrated TD measuring equipment. The unit has following specifications:

- Output voltage 28kVpeak, 20kVrms;
- Pure sinusoidal output voltage(load-independent);
- Output current 20mA max;
- Highest test capacity of 10μF;
- Internal TD measurement with high accuracy ( $1 \times 10^{-4}$ );
- Tan Delta measurement with various frequencies (0,01 – 0,1 Hz);
- Cable testing according to the standards:  
CENELEC HD 620/621, IEEE 400.2-2004, IEEE 400-2001, etc.



Figure 8: Measurement of TD

On each phase-line of cable we perform a measurement in four steps according to Table 1. Each step has five measurements or takes two minutes. For the test to start we need additional info from the cable manufacturer and/or user so that we can determine the appropriate voltage levels and acceptance criteria.

For acceptance criteria we use standard IEEE 400.2 – IEEE Guide for Field Testing of Shielded Power Cable Systems Using Very Low Frequency (VLF).

All results can be displayed on-line on a personal computer or on the instrument.

Calculating the appropriate voltage levels:

$$U_0 = \frac{U_N}{\sqrt{3}} \quad (2)$$

$U_0$  – Output voltage

$U_N$  – Nominal voltage of one phase

Table 1: Course of steps

step	voltage
1	0,5 $U_0$
2	$U_0$
3	1,5 $U_0$
4	2 $U_0$



### 3.3 Partial Discharge Basic

Partial Discharge (PD) is a localized dielectric breakdown of a small portion of a solid or fluid electrical insulation system under high voltage stress, which does not bridge the space between two conductors. PD affect the surrounding isolating material through heat, chemical reaction, light emission. Damaged isolation material leads often to the formation of electrical trees with the subsequence of breakdown.

A long high voltage cable behaves as a wave guide. The cable has a conductor, a dielectric and a coaxial neutral (Screen copper tape or lead) which forms an ideal wave guide. The dielectric creates a large capacitor. The longer the cable, the more of these capacitors are in parallel. These PD waves travel down the wave guide – one PD wave to the one end of the cable and the other PD pulse to the opposite end. If we now place a capturing device – a coupling capacitor and a Digital Storage Oscilloscope at the one end, it is possible to view the “time of flight” of these PD pulses.

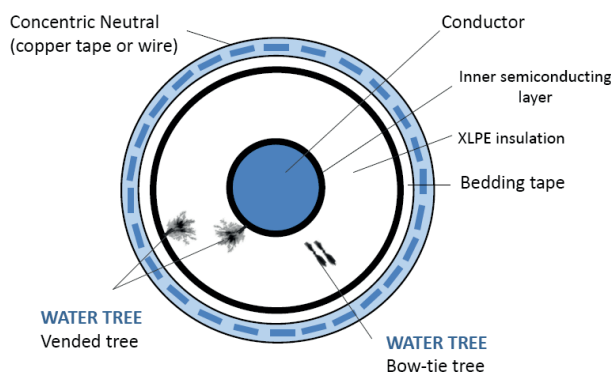

Figure 9: Typical XLPE cable

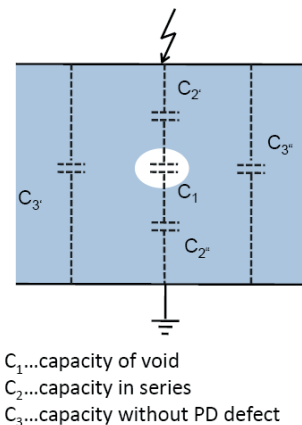

Figure 10: PD schematic representation

The 1st PD pulse in the echogram below (emanating from the PD source) arrives first at the coupling unit (see Figure 11. blue pulse ) whilst the 2nd pulse travels to the far end, travels the full length of the cable and arrives at the coupling unit (see green pulse). The 1st pulse reflects out of the coupling unit and travels to the far end and reflects back hence 3rd pulse.  $\Delta t_2$  is therefore the time differences between these two incoming pulses and the time to the PD source from the far end. If we now know the velocity of propagation of the PD pulse in the cable we can calculate the distance to the PD source (Dist = Velocity x time)

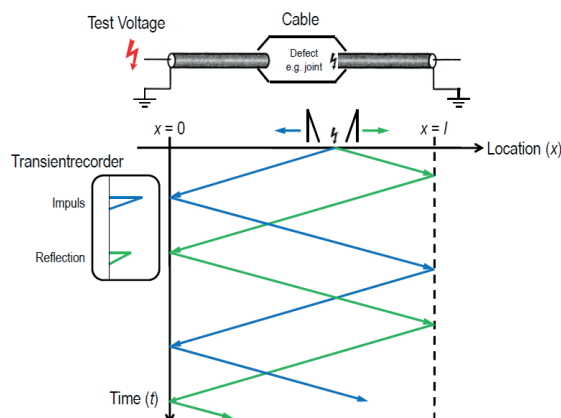

Figure 11: PD pulse travel diagram

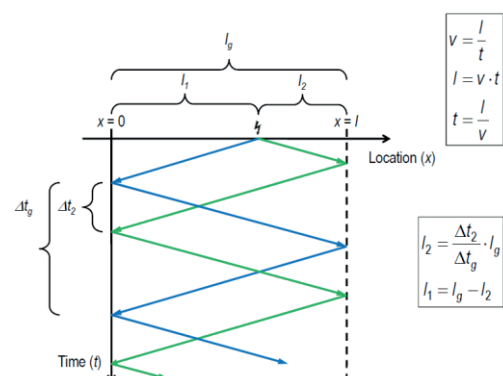

Figure 12: Distance to PD calculation

Unfortunately on very long cables the subsequent reflections may be attenuated to such an extent that they are not visible. Joint/splices also attenuate these pulses. PILC cables have a greater attenuation on these traveling PD waves than that of a similar XLPE cable. If the returning pulse (2nd) is not visible it is not possible to do a location. The 1st pulse only indicates that there is a discharge on the cable. By examining the rise times of the calibration pulse and this PD pulse it is possible to determine if it is from the near end termination or not.

### 3.4 PD Measurements

For measurement we need a high voltage power supply, for that we use the unit used for TD measurements. Additionally we need a PD detector to detect the partial discharges and calibrator to get the accurate cable length so that we can determine the location of the fault.

During the measurement all results are transmitted directly to the PC. There we can define the noise level, filters, calibrate the cable set - length, measure the PD events and analyze the results. PD measurements take more time and results are much more complex to analyze. The definition of the voltage steps is the same as used in TD measurements.

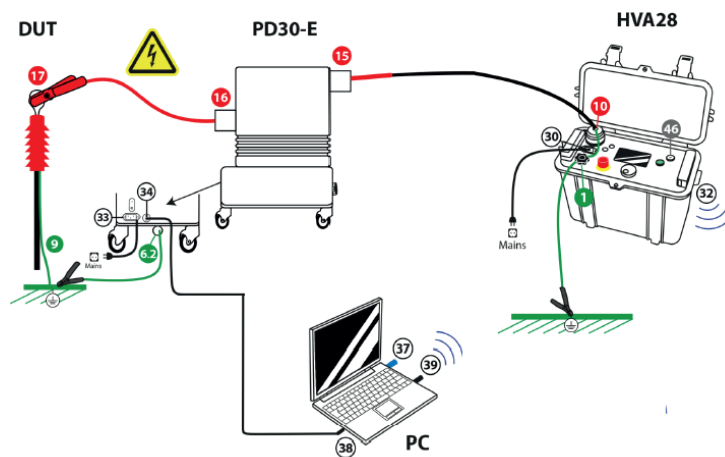

Figure 13: PD Measurement setup

There is not yet any standard from where we can get the acceptance criteria. There are only *b2 electronic GmbH* standards shown in Figure 14. The best practice is to monitor the cables and look at the trending – sudden changes in the cable insulation. Therefore we actively participate in international conferences and courses related to this topic where we can exchange knowledge and experience.

XLPE Cables	0 pC - 50 pC	Discharge within acceptable limits
	50 pC - 150 pC	Some concern, monitoring recommended
	150 pC - 500 pC	Some concern, regular monitoring recommended
	> 500 pC	Major concern, repair or replace
EPR Cables Joint & termination XLPE	< 500 pC	Discharge within acceptable limits
	500 pC - 1 nC	Some concern, monitoring recommended
	1 nC - 2.5 nC	Some concern, regular monitoring recommended
	> 2.5 nC	Major concern, repair or replace

Figure 14: b2 standard for PD Tolerance Levels for MV Cables

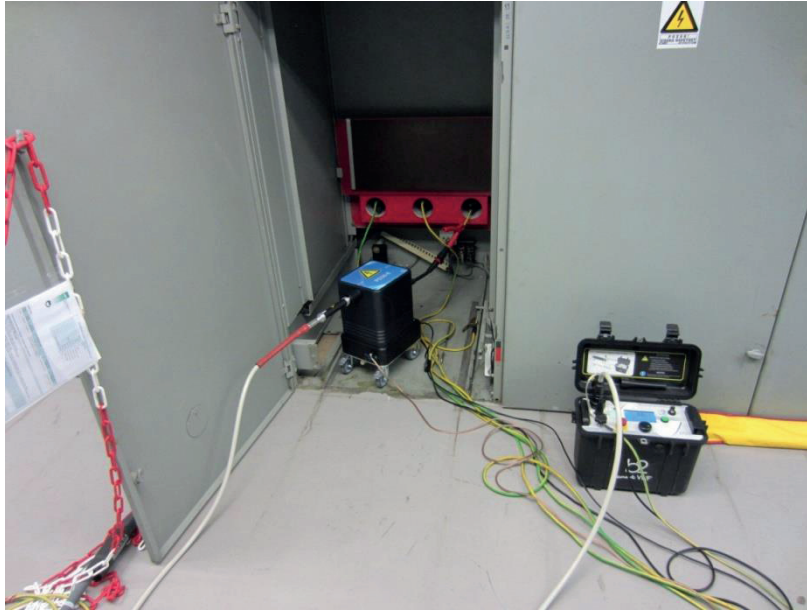

Figure 15: Measurement of PD

#### 4 RESULTS ANALYSIS

The analysis of the results for TD is done according to standard IEEE 400.2 – IEEE Guide for Field Testing of Shielded Power Cable Systems Using Very Low Frequency (VLF). We are also cooperating with other companies and utilities with whom we compare the results.

The results of the measurements depend on the type of the insulation that is used in a cable. TD assessment criteria for different cable insulations can be seen in tables 2 and 3.

Table 2: IEEE 400.2 -2013a ranges in the TD assessment criteria for XPLE insulation cables

Condition assessment	TD stability (measured by standard deviation) at $U_0$ [ $10^{-3}$ ]		Differential TD (difference in mean TD) between $2U_0$ and $U_0$ [ $10^{-3}$ ]		Mean TD at $2U_0$ [ $10^{-3}$ ]
No Action Required	< 0.1	and	< 0.6	and	< 1.2
Further Study Advised	0.1 to 0.5	or	0.6 to 1	or	1.2 to 2
Action Required	> 0.5	or	> 1	or	> 2

Table 3: IEEE 400.2 -2013a ranges in the TD assessment criteria for EPR insulation cables

Condition assessment	TD stability (measured by standard deviation) at $U_0$ [ $10^{-3}$ ]		Differential TD (difference in mean TD) between $2U_0$ and $U_0$ [ $10^{-3}$ ]		Mean TD at $2U_0$ [ $10^{-3}$ ]
No Action Required	< 0.5	and	< 4	and	< 10
Further Study Advised	0.5 to 1	or	4 to 10	or	10 to 80
Action Required	> 1	or	> 10	or	> 80

In Figure 16. we see a constant rise in the measured TD values. This indicates good insulation that does not change when the voltage increases. Also all the measured values are in the acceptance criteria for EPR insulation.

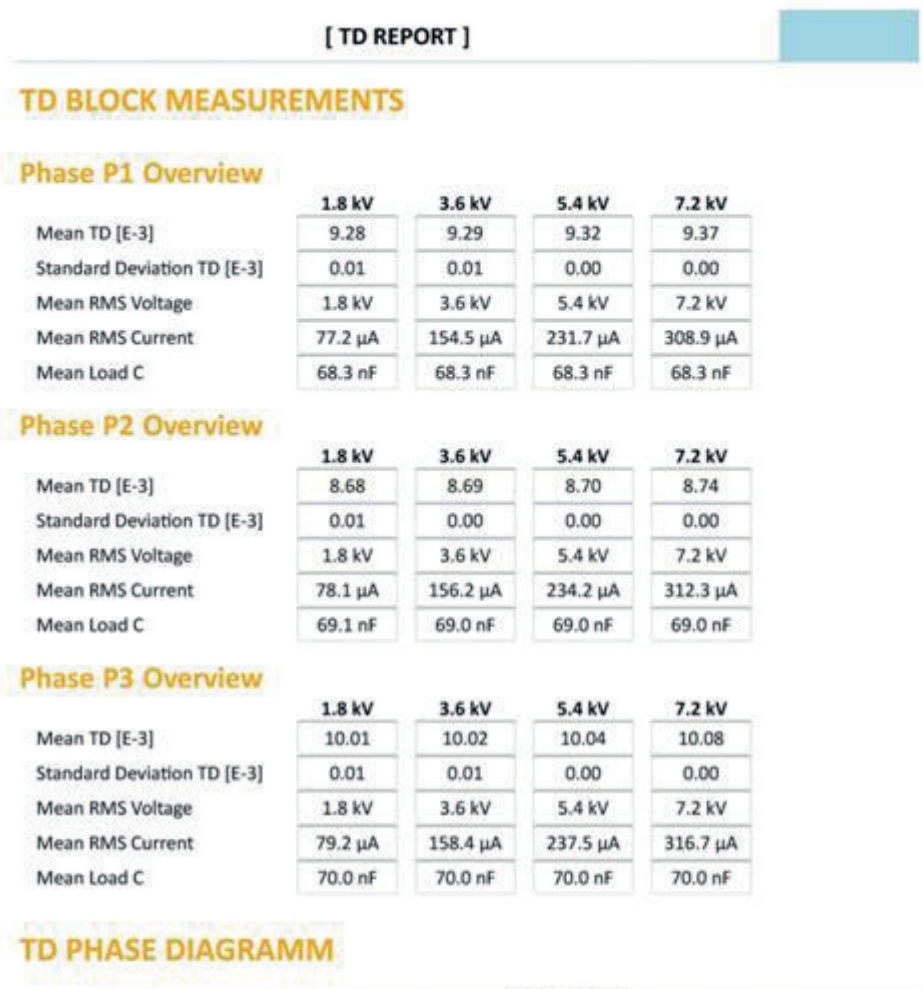

### TD PHASE DIAGRAMM

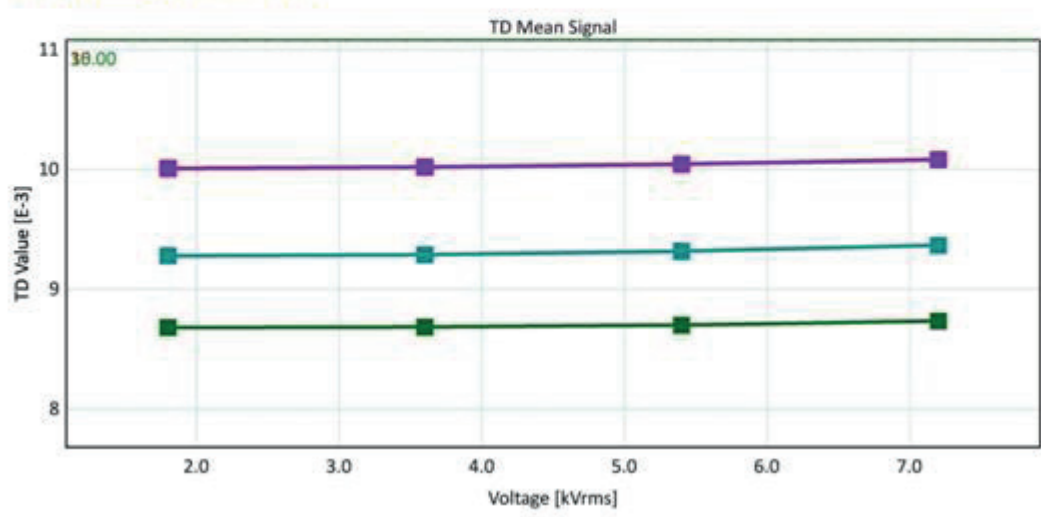

Figure 16: Example report of TD measurement

Analysis of the PD events is a completely different matter. There is no standard for the acceptance criteria for Field Testing of Shielded Power Cable Systems Using Very Low Frequency (VLF). Mainly look at the peak values that occur repeatedly at the same place and then we summarize and analyze them. We have to watch for joints and splices which are usually the main source of the

PD events. When we define them and define the location of the event we have to do a visual inspection of the localized event.

Additional info matter can be found when we are measuring the Inception and Extinction voltage, Impulse rate  $n$ , PD level :

- $U_i$  Inception voltage - the first PD occur at Inception voltage
- $U_e$  Extinction voltage - Test voltage slowly decreased – PD stops at extinction voltage
- Impulse rate  $n$  - Number of PD impulses / time range
- PD level - Strength of the PD signal measured.

With analysis of the parameters above we can predict the severity of the PD event.

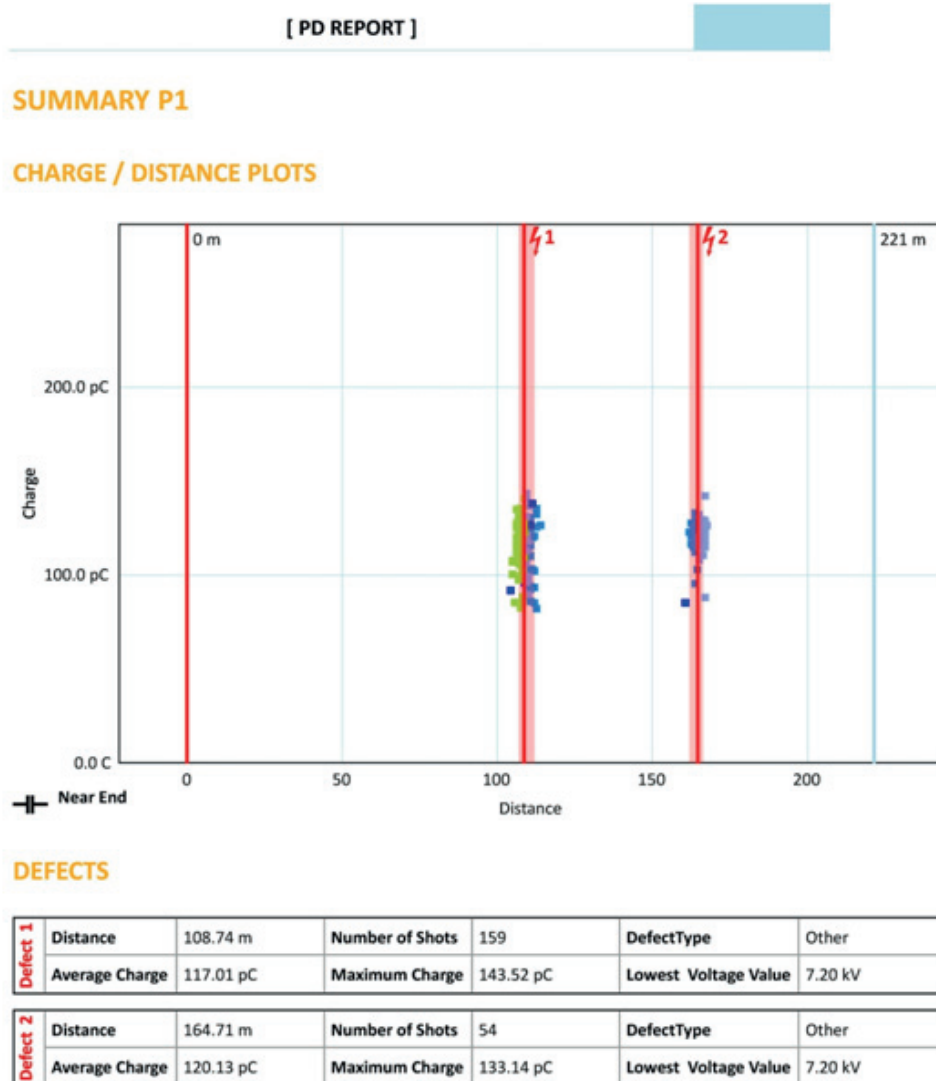

Figure 17: Example report of PD measurement

In Figure 17. we can see a cable set that has 2 locations with many PD events. After the visual inspection we determined that location 2 is a splice location in a manhole. The other one is a dilatation conduit that has moved slightly during the years of operation of the power plant. All measured results had a very low peak value, therefore it was advised to look at the trending if the cable is degrading with years.

## 5 CONCLUSION

LIRA is a frequency domain system for condition monitoring of electrical cables. This paper shows some laboratory and field cases where LIRA was used to successfully detect locations where the cable insulation was degraded because of thermal, electrical or mechanical stress. The system is used for assessing the conditions of installed signal, medium and high voltage cables.

Tan Delta ( Loss Angle or Dissipation Factor) testing, is a diagnostic method of testing cables to determine the quality of the cable insulation. The analysis of the results for TD presented in this paper is done according to standard IEEE 400.2.

Analysis of the PD events is a complex matter. The best practice that other utilities are performing is to do as many measurements as possible and to compare the results and also repeat them periodically. This way we can look at the trending of the results. The best way would be if first we could take a fingerprint of new cable before installation in field and then taking periodic measurements and comparing results.

Nevertheless there are new fields of cable measurements that should be explored and standardized in an attempt to ensure better maintenance and tracking of cable lifetime.

## REFERENCES

- [1] IEEE 400.2-2013, IEEE Guide for Field Testing of Shielded Power Cable Systems Using Very Low Frequency (VLF)(less than 1 Hz), STANDARD IEEE, 6 September 2013
- [2] Wirescan AS, Norway CS R1 LIRA User Manual, July 2015
- [3] P.F. Fantoni, Cable Ageing Management and Condition Monitoring Using Line Impedance Resonance Analysis (LIRA), PLIM&PLEX Europe, Budapest, 15 April 2015
- [4] International Atomic Energy Agency, Assessing and Managing Cable Ageing in Nuclear Power Plants No. NP-T-3.6 , 2012
- [5] b2 Suite User manual DHV0048 Rev02, 2015