

ANA DRANDIĆ<sup>1</sup> ANTE MARUŠIĆ<sup>1</sup> MARINO DRANDIĆ<sup>2</sup> JURAJ HAVELKA<sup>1</sup>

[ana.drantic@fer.hr](mailto:ana.drantic@fer.hr)   [ante.marusic@fer.hr](mailto:ante.marusic@fer.hr)   [marino.drantic@elput.hr](mailto:marino.drantic@elput.hr)   [juraj.havelka@fer.hr](mailto:juraj.havelka@fer.hr)

<sup>1</sup> University of Zagreb Faculty of Electrical Engineering and Computing

<sup>2</sup> ELPUT d.o.o., Pula, Croatia

## POWER SYSTEM NEUTRAL POINT GROUNDING

### SUMMARY

The method used for neutral point grounding is very important for power network operation. There are many ways of grounding, which are used in practice, and the decision on the method of neutral grounding depends on the situation in the network connected to the substation. When deciding on the method of neutral grounding it is necessary to thoroughly consider all the advantages and disadvantages of individual modes of neutral grounding, and then choose the best technical and economical solution.

This paper analyzes the ways of neutral point grounding in medium voltage networks used in the current practice in Croatia which are isolated neutral point, low resistance earthing, partial compensation and resonant earthing. The use of shunt circuit-breaker is also described. Additionally, a survey of the relays used for the neutral point grounding system inside the substations was conducted and a brief analysis of the results is presented in the paper.

**Key words:** Neutral point grounding, compensation coil, shunt trip circuit-breaker, earth-fault protection, earth fault.

## 1. INTRODUCTION

Optimal selection of the grounding method for the neutral point is of great importance for the operation of the medium voltage networks since different concepts affect the different shapes and values of overvoltages and fault currents, which represent the most common type of malfunction in the network. The grounding mode selection directly affects network operating conditions, power quality, human security, and the choice of earthing protection concept.

In Europe, there is no unique concept of grounding the neutral point. There are many works that describe the possible grounding methods and the protection of networks depending on the grounding method [1-10]. Many factors influence the neutral point grounding. One them is the value of the capacitive current. In more developed distribution networks, with a relatively large number of electricity customers, and due to systematic cabling, the capacitive currents have reached such a level that the change of grounding system was necessary, such as switching from the low-ohmic resistor grounding to resonant grounding [3].

The reasons to ground the neutral point are:

- rise in the number of cable networks - leads to a higher value of capacitive current,
- single-phase failure current increase,
- network expansion,
- demand to increase the quality of electricity supply.

A large number of different grounding methods used for neutral point grounding is the result of concessions between two main and mutually opposite requirements [5]:

- reduction of the earth fault current amplitude, which can cause trouble when detecting faults,
- permitting larger earth fault current amplitudes, which makes it easier to detect earth faults, but can cause dangerous contact voltages, and cause more power outages.

In order to be able to adjust the relay protection of the network, it is necessary to know the voltage and current voltages that are established in the stationary state after a single-phase fault. In order to properly identify the type of fault and the reaction of the relay protection, it is necessary to know network configuration and the method of neutral point grounding.

Due to different conditions in networks and national regulations, there are various technical solutions for grounding the neutral point in Europe [5]:

- isolated neutral point,
- direct grounding,
- low-impedance grounded neutral point,
- low-ohmic grounded neutral point,
- high-impedance grounded neutral point,

- partial compensation,
- resonant grounded neutral point.

The use and protection of network with low-ohmic grounded neutral point is presented in [11], a proposal of partial compensation use is presented in [12], examples of the use of resonant grounded neutral point are given in [13-15], and [16] presents the usefulness of the shunt circuit-breaker.

This paper gives the technical overview of the grounding methods for neutral point in medium voltage networks used in Croatia and is based on the information in [1] and [2]. Additionally, the use of shunt circuit-breaker is also described since its' use in the networks grounded by low-ohmic resistor or networks with partial compensation means that it is possible, depending on the capacitive currents, to use it as a more economical alternative to resonant grounding. Analysis of the protective relays used for protection in 35/10(20) kV substations is also presented.

## 2. THEORETICAL OVERVIEW

In Croatia, four ways of grounding the neutral point are used in medium voltage networks:

- isolated neutral point,
- low-ohmic grounded neutral point,
- partial compensation,
- resonant grounded neutral point.

In addition to these solutions, it is also necessary to observe the solution where the shunt trip circuit breaker is used. Its use can achieve similar effects as resonant grounding as it solves the problem of earth fault. As each phase can be individually switched on and off, the shunt trip circuit breaker is used as a solution for reducing the number of transient failures.

### 2.1. Isolated neutral point

The use of the isolated neutral point in the power system is the simplest and cheapest solution. In such a system, the neutral point is separated from the ground, and the only connection with the earth is realized through the earth capacitances of cables and overhead lines. During the earth fault, the currents flow through those capacitances of the healthy phases. The fault current depends on the capacitive current of the network and on the transient resistance [7]. In single-phase earth fault the voltages of the healthy phases can increase to the size of the line voltage. Then there is a danger of the occurrence of a two-phase earth fault in which the values of the currents are similar to the currents of the three-phase short circuit. If the network works in the state of earth fault for more than two hours, it is considered that the conditions for a two-phase earth fault to occur are met.

The insulated neutral point provides a continuous operation in the event of an earth fault, so that the fault can be removed in the best time for consumers. However, by network expansion, the currents of the earth fault become larger than the maximally allowed currents for the network which is 10 A for the 35 kV network, 15 A for 20 kV, 20 A for 10 kV, and 30 A for 6 kV network. Then, the isolated neutral point use loses its main advantage, which is maintaining the conditions for single-phase earth fault to shut down itself without the need of relay protection or staff intervention [3]. This is particularly emphasized for cable networks that have large earth capacitances and the fault currents are greater than in overhead networks.

Figure 1 shows the current flow in the grid when there is an earth fault at phase L1 assuming that a stable earth fault without transient resistance has occurred. Vector diagram for this kind of earth fault is depicted in Fig.2. As shown on the vector diagram, the neutral point voltage towards earth is the phase voltage size, while the voltage levels of the healthy phases towards earth are of the line voltage size.

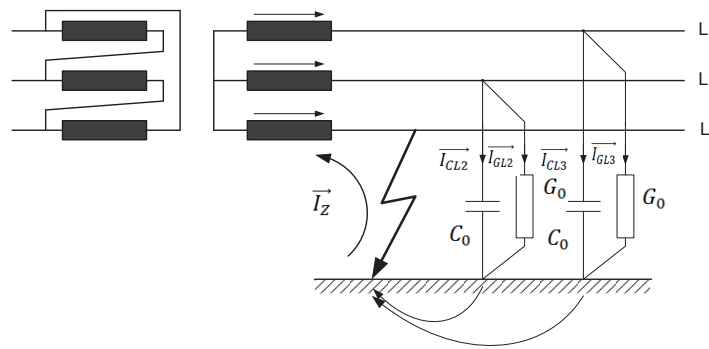

Figure 1 Current flows in the grid at earth fault in phase L1

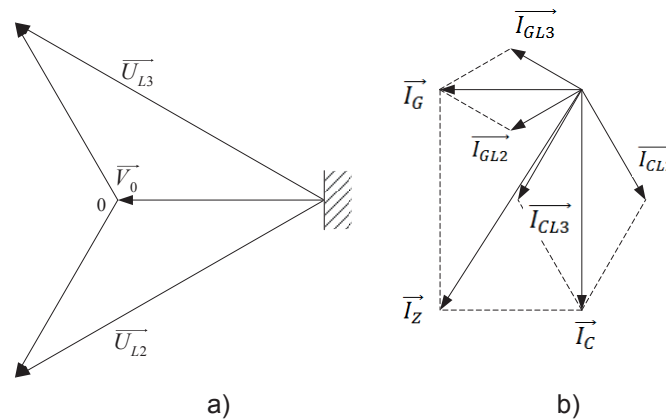

Figure 2 Vector diagram for a) voltages and b) currents at earth fault in phase L1

From Fig.1. and Fig.2 for the capacitive current  $\vec{I}_C$  and conductance current  $\vec{I}_G$  it can be easily written [8]:

$$\vec{I}_C = 3 * \vec{V}_F * C_0 * j\omega \quad (1)$$

$$\vec{I}_G = 3 * \vec{V}_F * G_0 \quad (2)$$

Where  $\vec{V}_F$  is the vector of the rated phase voltage,  $C_0$  is the earth capacitance, and  $G_0$  is the conductance.

Looking at the vector diagram it can be concluded that the earth fault current  $|I_Z|$  is:

$$|I_Z| = \sqrt{|I_G|^2 + |I_C|^2} \approx |I_C|. \quad (3)$$

$|I_G|$  is usually not larger than a small percentage of  $|I_C|$ .  $\vec{V}_F$  je vektor nazivnog faznog napona.

As already mentioned, in isolated neutral point networks single-phase earth faults do not need to be switched off automatically since the currents are small and the network can remain in operation until the fault is detected. This allows the fault to turn off by itself. After the earth fault current is switched off, a return voltage occurs whose amplitude can be up to two times the amplitude of the rated phase voltage. This greatly obstructs the conditions of self-shutdown and can lead to reignition of the arc which will further cause intermittent overvoltages. Intermittent overvoltages are the consequence of the superposition of potentials after each reignition of the arc to a static potential from the previous shutdown of the arc. The occurrence of intermittent overvoltages in isolated neutral point networks can not be prevented. But it is rare in distribution networks and the surges themselves do not endanger properly dimensioned isolation. Only where the insulation is weaker due to improper design or damage there is a risk of expansion on a double earth fault.

Network protection under such conditions is often only signalization and personnel on duty have enough time to detect the earth fault and take measures to solve the problem. Networks with isolated neutral point are allowed operation if the capacitive earth current is not too large. If the capacitive current exceeds the previously mentioned values, it is recommended to divide the network or ground the neutral point.

The advantages of isolated neutral point networks are as follows [5]:

- the arc will be extinguished if it is a transient failure for earth fault with relatively low capacitive currents. This increases the quality of electricity supply,
- relatively easy earthing design,
- simplicity and economical design,
- possibility to resume network operation until the fault is located.

The disadvantages of these networks are:

- possibility of intermittent overvoltages with a high surge voltage factor,
- higher internal surges compared to when the grid is earthed,
- more difficult detection of faults compared to when the network is earthed,
- in case of high- capacitance earth fault currents, no self-shutdown of the fault.

## 2.2. Low-ohmic resistor grounding of neutral point

Distribution networks are grounded via low-ohmic resistance if the capacitive current exceeds the values mentioned in the previous subsection. This reduces the internal voltage surges, eliminates the possibility of intermittent overvoltages and provides a more reliable protection.

In this grounding system, the single-phase fault current is closed not only through the zero capacitances of the healthy phases, but also through the low-ohmic resistance. This earth fault current, which is increased in comparison to the current when neutral point is isolated, provides a stable electric arc at the place of fault, thus preventing the formation of intermittent overvoltages. Even with consecutive reignition of the arc no static potential can be achieved. With larger fault currents it is easier to detect the fault and design the protection, but there is a problem of network disconnection at each fault, which interrupts the supply of electricity to the consumers [9].

For networks grounded over a small resistor  $R_Z$ , shown in Fig.3, every earth fault in the network must be switched off as it is a short circuit. The earth fault current  $\vec{I}_Z$  is [8]:

$$\vec{I}_Z = \frac{3*\vec{V}_F}{\vec{Z}_d + \vec{Z}_i + \vec{Z}_0} \approx \frac{3*\vec{V}_F}{2*\vec{Z}_{v+T} + \vec{Z}_{0v+T} + 3*R_Z}. \quad (4)$$

where  $\vec{Z}_d, \vec{Z}_i, \vec{Z}_0$  are the vectors of the direct, inverse and zero impedance of the network in the location of the fault,  $\vec{V}_F$  is the vector of the rated phase voltage, and  $\vec{Z}_{v+T}$  and  $\vec{Z}_{0v+T}$  are the vectors of the operational and zero impedance of the transformer and faulty line.

Since following expression is usually valid:

$$3 * R_Z \gg |2 * \vec{Z}_{v+T} + \vec{Z}_{0v+T}|, \quad (5)$$

the earth fault current can be calculated with:

$$\vec{I}_Z \approx \frac{\vec{V}_F}{R_Z}. \quad (6)$$

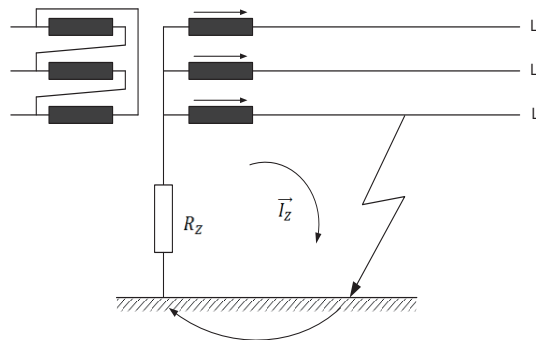

Figure 3 Current flows in the grid at earth fault in phase L1

When selecting the resistor size for neutral point grounding two conflicting criteria should be considered [10]:

- technical regulations on the dangerous contact voltages in substations,
- the values of the internal overvoltages occurring when single-phase faults occur.

According to the criteria for dangerous contact voltages it is desirable to have a low single-phase fault current so that the contact voltages are lower. On the other hand, it is desirable that the current is large as much as possible to allow the internal surge voltages, which can break the insulation during the faults, to be as low as possible. In order for the internal voltage surges to remain within the acceptable values, the resistor should be selected so that it satisfies the criterion  $I_R:I_C \geq 3:1$ , or  $I_R:I_C \geq 1,5:1$  when the rounding conditions are difficult.

For networks grounded with a low-ohmic resistor the earth fault must be switched off as soon as possible due to high values of the fault current that are limited by the resistance value of the resistor. Compared to the isolated networks, in these networks there is a breakdown protection for the resistor itself. The resistor connection to the neutral point of the transformer along with the protection scheme is shown in Fig. 4.

For the selection of the protection, the relevant current is the earth fault current  $I_{K1}$ , the remaining current of the faulty line when earth capacitances are ignored  $\vec{I}_{k1}$ , and the residual current in the health line  $\vec{I}_{r1}$ . They can be calculated with the following equations [11]:

$$I_{K1} = \frac{\sqrt{3} * U_n}{2 * Z_d + Z_0 + 3 * R_n + 3 * Z_K'} \quad (7)$$

$$\vec{I}_{r1} = \vec{I}_{K1}, \quad (8)$$

$$\vec{I}_{r1} = 3 * \vec{I}_{02} = - \frac{3 * j\omega * C_{02} * R_Z * \vec{V}}{R_Z + R_K * (1 + 3 * j\omega * C_0 * R_Z)}, \quad (9)$$

where  $\vec{I}_{02}$  is the vector current of the healthy line,  $C_{02}$  is the earth capacitance of the healthy line, and  $C_0$  is the total earth network capacitance.

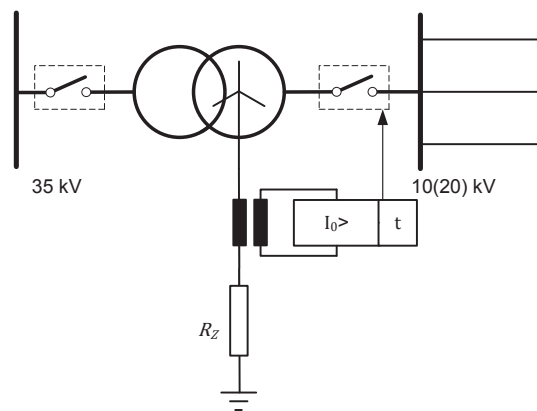

Figure 4 Low-ohmic grounded neutral point protection

The earthing resistor used in Croatia, depending on the network type, is chosen so it satisfies single-fault current limitation limits of 300 A, 150 A and 50 A. The relay protection of these networks consists of the protection of medium voltage lines, transformers protection, and resistors protection.

The advantages of grounding networks grounded via low-ohmic resistors are [11]:

- simple and reliable protection when compared to the isolated neutral point networks,
- no intermittent overvoltages,
- lower internal voltage surges when compared to the isolated neutral point networks,
- easier detection of fault location.

The disadvantages of such grounded networks are [11]:

- all faults cause power outages, which is undesirable due to reduced quality of electricity supply,
- higher values of fault currents when compared to the isolated neutral point networks which means dangerous contact voltages.

### 2.3. Partial compensation

Partial compensation is the name for type of network grounding by means of parallel coil and low-ohmic resistor. The neutral point grounding by means of a parallel coupling of a fixed coil and a low-ohmic resistor represents a technical solution that is of a transitional character depending on the magnitude of the capacitive current of the network. This solution is an upgrade to the technical solution of the grounding via the low-ohmic resistor. It is economically acceptable, especially for capacitive currents up to about 150 A after which the grounding should be done by means of an automatically adjustable arc suppression coil.

Owing to the power network expansion, especially the greater number of cable lines, the capacitive currents in the network are increased. When the capacitive current of the network exceeds 50 A for dangerous contact voltages it is preferable to limit the current of single-phase fault. A technical solution for the capacitive current cutoff consists of a parallel connection of a manually adjustable coil with an existing low-ohmic resistor. In Croatia, a 150 A and 50 A short-circuit current resistor is used in combination with a 30-to-150 A fixed coil with the ability of manual adjustments in seven degrees of 20 A.

Such a solution achieves partial compensation with the residual minimum reactive current, while still retaining other features of the low-ohmic resistor grounding and therefore no changes in protective devices are required. Manual regulation is carried out in a state without voltage.

Due to the inductive current, the system can be sub-compensated or overcompensated, and therefore a fault current can be found either in III. or II. quadrant compared to the reference voltage of the neutral point. Compared to the



automatically adjustable arc suppression coil, a manually adjustable coil, which is combined with a parallel low-ohmic resistor, is not designed to shut off short-term faults, but only serves for the compensation of the capacitive current component.

Resistor current selection depends on the size of the contact voltages defined by the technical regulations. A single-phase short circuit current through the neutral point is dictated by the current limited by the resistor. Inductive current of the coil reduces the capacitive current of the network. For partial compensation with a fixed coil and a low-ohmic resistor the residual value of the capacitive current  $I_C$  in the network is [12]:

$$I_C = I_{Cnetwork} - I_L, \quad (10)$$

where  $I_{Cnetwork}$  is the network capacitive current and  $I_L$  is the inductive current of the coil. The current of the single-phase fault  $I_{1k}$  is then:

$$I_{1k} = \sqrt{I_R^2 + I_C^2}, \quad (11)$$

where  $I_R$  is the current limited by the resistor.

The relay protection located in power transformer cells consists of the protection of medium voltage lines, protection of transformers and protection of resistors in combination with a fixed coil. Transformers are usually protected by short-circuit protection, overload protection and single-phase fault protection, and larger units also with differential protection. Transformer protection is coupled to the primary side so that the single-phase transformer fault depends on the neutral point grounding of the voltage to which a transformer is connected. Medium voltage lines are protected by short-circuit protection, overload protection and single-phase short-circuit protection.

Relay protection of transformers, lines and the combination resistor-coil is the same as in the networks grounded with low-ohmic resistors. The protection of a single-phase short circuit in network with partial compensation is shown in Fig. 5. The protection of the resistor consists of a three-stage overcurrent protection, which ensures protection against breakdown, protection of single-phase fault in lines and protection against high-ohmic faults in the network.

The advantages of networks with partial compensation are [12]:

- It is an economically good solution if previously the network was grounded via a low-ohmic resistor,
- no additional investment is required,
- the internal voltage surges are slightly lower than in the low-ohmic resistor networks,
- it is not necessary to change the protection system if previously the network was grounded via a low-ohmic resistor,
- no intermittent overvoltages.

Disadvantages of these networks are [12]:

all faults cause power outages, which is undesirable due to reduced quality of electricity supply.

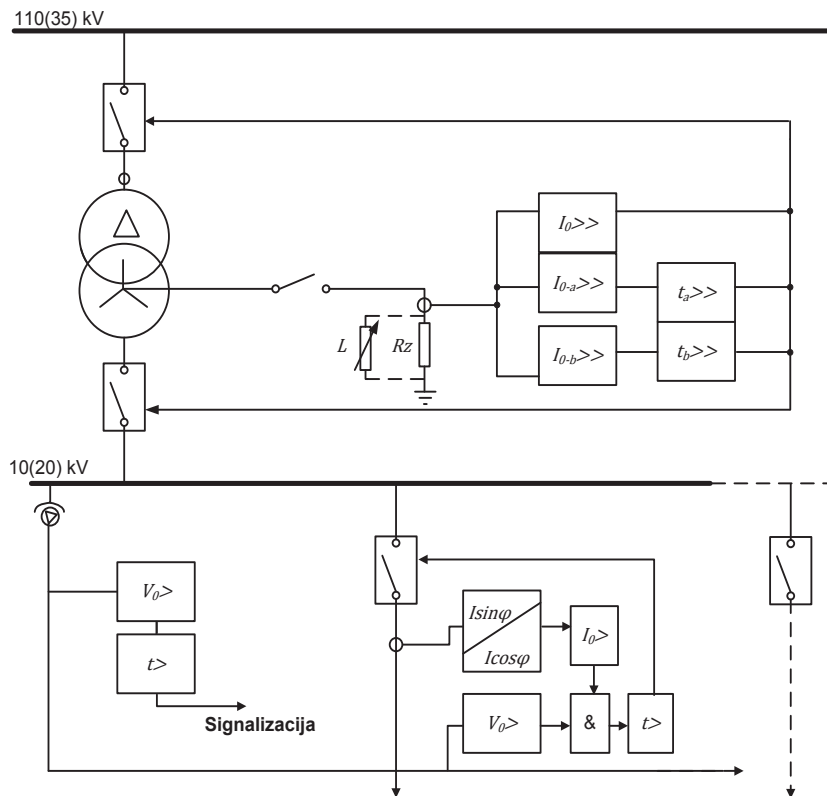

Figure 5 Schematic of protection for partial compensation network

#### 2.4. Resonant grounded neutral point

As was already mentioned, more frequent use of cable lines in the power networks causes increase of capacitive currents [13]. The consequences are an increase of the internal voltage surges as well as the earth fault currents. When the single-phase earth fault current is greater than the maximum permissible, the operation of the network with the isolated neutral point is not possible because the likelihood of self-shutdown of the fault is reduced. This is just one of the reasons why lately the resonant grounding is considered more frequently. This type of grounding is achieved by the grounding of the neutral point via an automatic compensating coil also called Petersen coil [14].

The application of the resonant grounding shows the best results if the inductance of the compensating coil is adapted to the earth capacity of the network. Such grounding reduces currents of earth faults and slows down the recovery voltage over the fault location. This leads to higher maximum permissible fault currents compared to the isolated networks.

The principle of the compensating coil consists of compensating capacitive currents in the network by means of variable inductance as an active part of the network [13]. Fig. 6 shows conditions during the earth fault in phase L1 of the compensated network with negligible low resistance of the arc  $R_K$  at the fault location. It is assumed that the line impedance and admittance are negligible. Since

the coil is connected between the neutral point of the power transformer and the earth, the compensating coil only affects the zero-system scheme.

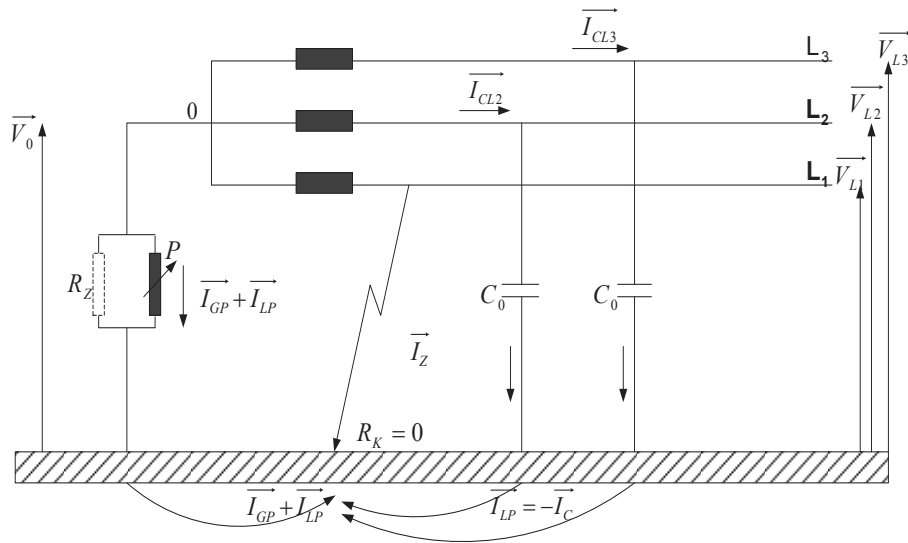

Figure 6 Earth fault in network with resonant grounded neutral point

In the circuit with resonance shown in Fig. 6 the fault current has only a small value of the resistive component if the inductance of the coil is set to the value of the network zero admittance. A small value of the resistive current component is caused by the ohmic resistance of the coil and the network line. Parallel resistance  $R_Z$  is often added to such grounding system with the task to increase the fault current in order to create conditions for relay protection selectivity.

The fault current  $\vec{I}_Z$  is divided into two parts. One of these parts, which consists of the inductive component of coil current  $\vec{I}_{LP}$  and the resistive component of coil current  $\vec{I}_{GP}$ , flows from the coil to the fault location, then to the faulty phase of the faulted line, and then to the neutral point of the transformer. When the networks are fully compensated this current consists only of the active components of the line current and the coil. The second part of the current, the currents of the healthy phases  $\vec{I}_{CL2}$  and  $\vec{I}_{CL3}$  are summed up and generate the total capacitive current  $\vec{I}_C$ . It closes the capacitive current circuits across the earth and comes to the fault location where it is suppressed or compensated with the coil current  $\vec{I}_{LP}$ . With ideal compensation of the capacitive current, its' value corresponds to the current of the coil.

In Fig. 7 a vector diagram of the voltages and currents for the considered fault is presented, in which, as a reference, the voltage vector of the affected phase is adopted. The picture is drawn in case of complete compensation.

The protection of resonant grounded networks is most commonly performed with earth fault relays which must be very sensitive due to small fault currents when compared to other grounding systems [15]. Most of the earth fault detection methods use measurements of the basic current and voltage harmonics. One of the standard methods of protection is the vatmeter method, but it has the sensitivity of the high-ohmic faults limited to several kilohms. While the sensitivity of digital

earth fault protection with time-specific or inverse characteristics is up to 15 k $\Omega$ , the vatmeter protection can selectively detect failures at resistance ranges up to 3 k $\Omega$ .

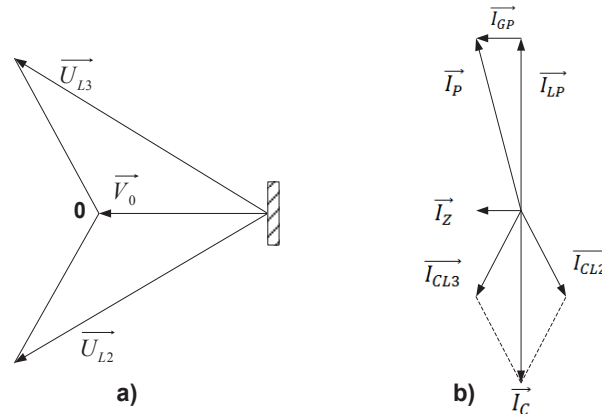

Figure 7 Vector diagram for a) voltages and b) currents for the case of full compensation

It should be noted that earthing via the coil is not efficient in the cable networks since there the earth fault presents a permanent fault and the cable must be switched off immediately.

The advantages of grounding through the compensating coil are:

- low current through the fault location enables self-shutdown of the fault, increasing the quality of electricity supply,
- a slower return voltage reduces the likelihood of intermittent overvoltage generation,
- the minimum risk of too high potential on transformer earthing leads to lower economic cost of the repairs,
- the least thermal stresses compared to other grounding systems,
- the current at fault location is reduced and the theoretically around zero,
- at fault location voltage is reduced to almost zero.

The disadvantages of resonant grounding are [14]:

- the need for more sensitive and therefore more expensive protection,
- considerable investment costs,
- a higher isolation level of equipment is needed as the healthy phase voltages rise to the line value of the voltage during earth fault.

## 2.5. Shunt circuit-breaker

As was mentioned in the previous chapters, numerous short-term faults can be technically solved by installing an automatic compensation coil. However, as the cost of installing the coil is high another way to reduce the number of power failures is needed. The solution is to use shunt circuit-breakers. Shunt circuit-breaker is a

three-phase circuit-breaker with three separate mechanisms, one for each pole. It is a technical solution developed in France, where it is mostly used.

If a single-phase short circuit occurs, the shunt circuit-breaker, along with the associated protective relay, detects the faulted phase. Then, the command for the corresponding pole of the circuit breaker is switched on connecting the faulty phase directly to the ground. The fault current, which was the arc current before, is then flowing through the pole of the shunt circuit breaker and a low-ohmic resistor with or without the parallel coil. This current is limited by the resistance of the low-ohmic resistors. At the fault location there is no longer any voltage to the ground, which would maintain an electric arc, and the arc will turn off if the failure is transient. After a certain time, which is usually set at a value between 150 and 300 ms, a command to switch off the pole of the shunt circuit-breaker is given. If the fault was transient, the network works normally after switching off the shunt circuit-breaker and consumers did not feel the fault existed because the line itself was not switched off. If it is not a transient fault, but a permanent one, the built-in earth fault protection switches off the faulty line after a certain set time.

Some of the criteria that should be considered when deciding to install shunt circuit-breakers are [16].:

- the number of transient faults,
- the share of overhead lines in the network,
- insulation level of the cable lines in the network,
- existing system of neutral point grounding,
- the power system user number and their requirements.

It is necessary to consider the event statistic of the network. Particular attention should be paid to the number of transient faults. The shunt circuit-breaker can solve this problem without the interruption of the electricity supply. If the insulation level of the cable part of the network is too low, after the installation and start of the shunt circuit-breaker operation malfunctions might be caused by overvoltages on the weakened parts of the network. Therefore, it is necessary that the insulation level is not too low or that the weakened cables are replaced.

The shunt circuit-breaker is installed in networks grounded via a low-ohmic resistance or partially compensated networks.

### **3. Analysis of protection relays used in 35/10(20) kV substations in Croatia**

Protective relays and their functions are responsible for the protection of the power system apparatus. A survey was sent to the 21 domain operators of the Croatian distribution system operator. The survey was answered by 13 domain operators: Zagreb (DP Elektra Zagreb), Split (DP Elektrodalmacija), Rijeka (DP Elektroprimorje), Pula (DP Elektroistra), Osijek (DP Elektroslavonija), Zadar (DP Elektra Zadar), Šibenik (DP Elektra Šibenik), Dubrovnik (DP Elektrojug), Karlovca

(DP Elektra Karlovac), Sisak (DP Elektra Sisak), Zabok (DP Elektra Zabok), Križ (DP Elektra Križ) and Vinkovci (DP Elektra Vinkovci). The survey encompasses the relay protection of 35/10(20) kV substations which present around 90-95% of substations in Croatia. Here, the analysis of relays used for the protection of the neutral point grounding system field is presented [2].

The total number of analyzed relays is 53. It can be seen from table I that 60,15% of the substations are equipped with numerical relays, 35,85% of the substations have static relays, and there are no electromechanical relays. Graphical representation of this is given in Fig.1.

Table I Relay types used in substations

<u>Type of relays</u>	<u>Nb. Of substations for the relay type</u>	<u>Nb. Of lines where the relay is embedded</u>
NUMERICAL	27	34
STATIC	15	19
E-M	0	0
HV FUSE	91	118

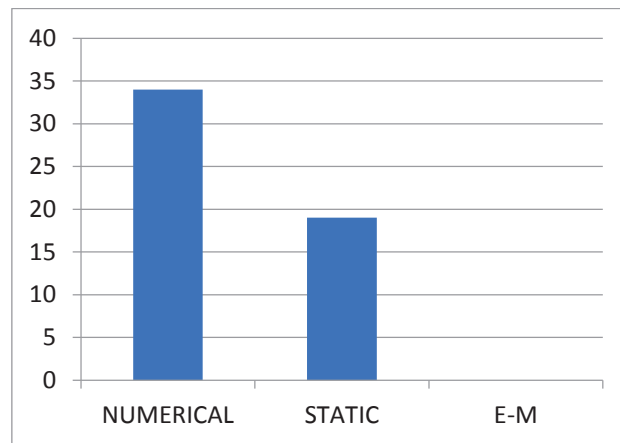

Figure 8 Graphical representation of used relays by type

Tables II and III give the data about the most used relays in substations and their activated functions. Table III gives data about most commonly used relays by operator domain. Operators of the domains usually prefer one or two manufacturers of the same relay as this means that it was easier for the communication between the remote-control center and the substations. Today, with the IEC 61850 standard used for communication this will no longer be necessary.

Table II The three most used relays in the substations for neutral point protection

<u>Manufacturer</u>	<u>Model (type)</u>	<u>Nb. Substations</u>	<u>Nb. Lines</u>	<u>Activated functions</u>
KONČAR	RIVC264E	5	9	I>, I>>
SIEMENS	7SJ600	7	8	I>, I>>, 50BF
ISKRA	TIF1220	7	7	I>

Table III The most common relay used in substations by operator domain

<u>Domain operator</u>	<u>Manufacturer</u>	<u>Model (type)</u>	<u>Nb. of substations</u>	<u>Nb. of fields</u>
KRIŽ				
VINKOVCI	SIEMENS	7SJ600	5	5
RIJEKA	KONČAR	RV117E	2	2
PULA	ISKRA	TFI1220	6	6
SISAK	SIEMENS	7SJ600	1	1
KARLOVAC	ALSTOM	P127	3	4
ZABOK	ALSTOM	P139	1	2
DUBROVNIK				
ZADAR	ABB	SPAJ324C4	3	3
ZAGREB				
OSIJEK	KONČAR	RIVC264E	4	8
SPLIT				
ŠIBENIK				

Data about relay manufacturers is given in Fig.2. The manufacturers are almost evenly represented, with a slight preference toward Končar.

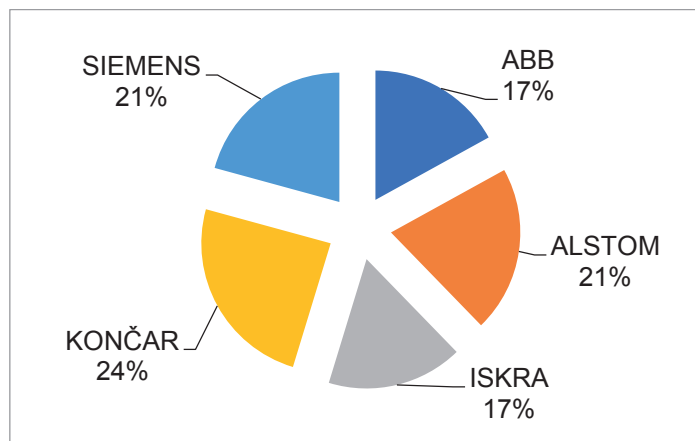

Figure 9 Graphical representation of used relays by manufacturer

Relay protection functions that are, according to the survey, used in the protection of the neutral point grounding system are:

- overcurrent protection ( $I>$ );
- instantaneous overcurrent protection ( $I>>$ );
- zero sequence overcurrent protection ( $I0>$ );
- instantaneous zero sequence overcurrent protection ( $I0>>$ );
- directional zero sequence overcurrent protection ( $I0>\square$ );
- directional overcurrent protection ( $I>\square$ );
- breaker failure protection (50BF);
- overvoltage protection ( $U>$ );
- undervoltage protection ( $U<$ );
- zero sequence overvoltage protection ( $U0>$ );
- zero sequence undervoltage protection ( $U0<$ ).

#### 4. CONCLUSION

The neutral point grounding method significantly influences network operating conditions, power stability, human security, the type and cost of equipment, and the choice of network configuration and relay protection. Given that each method has certain advantages and disadvantages, there is no single approach to the grounding of the neutral point of the medium voltage networks. This paper gives the overview of several ways to ground the neutral point of the medium voltage network. Additionally, the paper presents the analysis of the protective relays used for the protection of the neutral point grounding system in 35/10(20) kV substations in Croatia. Since not all of the domain operators have answered the survey a further analysis with larger data should be part of future research.

#### 5. REFERENCES

- [1]. A. Drandic, "Power system neutral grounding", M.S. thesis, FER Zagreb, 2014.
- [2]. M. Drandic, "Protective functions in substations 35/10(20) kV", M.S. thesis, FER Zagreb, 2012.
- [3]. J. Đerek, "Uzemljenje neutralne točke srednjenaponskih razdjelnih mreža", M.S. thesis, FER Zagreb, 2004.
- [4]. I. G. Kuliš, "Rezonantno uzemljenje neutralne točke srednjenaponskih mreža za distribuciju električne energije", M.Sc. thesis, FER, Zagreb, 2003.
- [5]. J. Ćurković, "Zemljospojna zaštita razdjelne mreže uzemljene preko kompenzacijske prigušnice", M.S. thesis, FER Zagreb, 2005.
- [6]. J.M. Nahman, *Uzemljenje neutralne tačke distributivnih mreža*, Naučna knjiga, Beograd, 1980.
- [7]. V. Komen, R. Ćučić, V. Sirotnjak, "Neutral point treatment in distribution networks", *HO CIRED 1.session*, Šibenik, 2008.
- [8]. F. Božuta, M. Golubović, *Aspekti zaštite elektroenergetskog sistema*, Svjetlost, Sarajevo, 1988.
- [9]. S. Žutobradić, M. Damianić M., "Konceptija uzemljenja zvjezdišta mreža 10(20) kV u budućnosti", *Journal of Energy*, nb.1, pp. 41-47., 1999.
- [10]. S. Žutobradić, "Aktualno stanje provedbe uzemljenja zvjezdišta srednjenaponskih mreža", *Journal of Energy*, nb. 4, pp. 203-208, 1993.
- [11]. S. Drandić, N. Rudan, "Izbor i podešavanje relejne zaštite maloohmskog otpornika za uzemljenje SN mreže primjenom digitalnih releja", *CIGRE 5. session*, Cavtat, 2001.



- [12]. E. Sterpin, "Prijedlog primjene kompenzacijske prigušnice s ručnom regulacijom u sprezi s otpornikom u mreži 10(20)kV Elektroistre", *Journal of Energy*, pp. 441.-446., 2005.
- [13]. G. Šagovac, I. Watson, "Improvement of quality of supply in medium voltage networks with resonant earthing of neutral point", *HO CIREĐ 1.session*, Šibenik, 2008.
- [14]. M. Damianić, "Analiza parametara uzemljenja zvjezdišta 10(20) kV mreže", M.Sc. thesis, FER Zagreb, 2001.
- [15]. D. Franković, "Određivanje parametara zaštitnih i regulacijskih uređaja u rezonantno uzemljenim srednjenaponskim mrežama", Ph.D. thesis, FER, Zagreb, 2009.
- [16]. V. Komen, R. Čučić, V. Sirotnjak, "Operating experiences in a distribution network with shunt circuit breaker", *HO CIREĐ 1.session*, Šibenik, 2008.