

Continuity of motivation in higher education: A three-year follow-up study

FLORIAN H. MÜLLER and MARKO PALEKČIĆ

This study investigates the question how the quality of students' learning motivation changes within a period of 3 years. Of special interest is which conditions of the learning environment are responsible for the stability or respectively the change of learning motivation. Deci and Ryan's (2002) self-determination theory (SDT) provides the theoretical foundation of this paper. It allows a differentiated analysis of the qualities of learning motivation (intrinsic motivation and four types of extrinsic motivation) and also suggests that motivational processes are highly influenced by basic psychological needs for autonomy, competence and social relatedness. On three different dates between 2003 and 2005, 104 students participated in a questionnaire. Overall, the longitudinal results show that the qualities of learning motivation remain relatively stable. In contrast, particularly the perceived support of autonomy and competence show a significant decline. The evaluation of social relatedness at university, between students and lecturers as well as between groups of students, remains stable on a high level during those three years. The social relatedness significantly correlates with learning motivation in all of the three assessments. The results are discussed in relation to situational and cultural conditions.

Key words: motivation, higher education, follow-up study

Why can some students sustain their learning motivation over a longer period of time, whereas others cannot? Why do some people enjoy studying over a longer period of time, whereas others show no inner drive to learn and rather study merely because they are expected to work hard or because they fear negative consequences?

Those are the questions this article investigates. It analyzes the longitudinal development of intrinsic and extrinsic learning motivation at university and the conditions responsible for the changes or the stability of study motivation. Its theoretical basis is a multidimensional perspective of motivation, the so-called self-determination theory (SDT) of Deci and Ryan (2002).

Over the last decades, many empirical studies were published providing a longitudinal analysis of the development and the conditions of learning motivation. The majority of

these studies concentrated on school education or vocational education (Baumert & Köller, 1998; Gottfried, Fleming, & Gottfried, 2001; Hardt, Zaib, Kleinbeck & Metz-Göckel, 1996; Harter, 1981; Helmke, 1993; Lepper, Henderlong, & Iyengar, 2002; Lewalter, Wild, & Krapp, 2001; Otis, Grouzet, & Pelletier, 2005; Prenzel, Kramer, & Drechsel, 2001; Wigfield & Harold, 1997; Wong, Wiest, & Cusick, 2002).

This research demonstrated that closely connected concepts, such as intrinsic motivation, interest¹ or enjoyment, tend to deteriorate over the years. This seems to be particularly the case in elementary and secondary school (Anderman & Maehr, 1994).

We will now briefly review exemplary longitudinal studies investigating the dynamics of learning motivation or related concepts:

Generally, we can identify a trend of decline concerning intrinsic motivation and subject-related interest in elementary school and early adolescence. Not until later adolescence learning motivation stabilizes increasingly (Gottfried et al., 2001; Todt, 1990). Hence, there are studies that reveal a decrease of interest in vocational education, but in general

Florian H. Müller, University of the Bundeswehr Munich, Fakultät für Pädagogik, Linprunstrasse 56, 80335 München, Germany. E-mail: florian.mueller@unibw.de (the address for correspondence);

Marko Palekčić, University of Zagreb, Faculty of Philosophy, Lučićeva 3, 10000 Zagreb, Croatia. E-mail: mpalekci@ffzg.hr.

Acknowledgments. This article is the result of a cooperation project between the University of the German Federal Armed Forces in Munich (Germany) and the Universities of Zagreb and Zadar (Croatia). We would like to particularly thank the students at the University of Zadar, who volunteered to participate in this longitudinal study.

¹ The terms intrinsic motivation and interest are not used as synonyms. Here, intrinsic motivation (see, for instance, Deci, 1975) is understood as motivational orientation and interest is interpreted as a relatively stable interest or accompany interest (Krapp, 2002).

motivational variables here remain relatively stable (K.-P. Wild & Krapp, 1996). At university or for further education we find an even stronger stabilization of intrinsic motivation for specific subjects. One reason appears to be that – compared to primary and secondary education – students are granted more autonomous options concerning the choice of their subjects or what they want to study in the first place. This enhances the congruence between personal interest and learning contents. Furthermore, increasingly with age, the development of one's identity strengthens personal dispositions, talents and interests and people generally feel more certain about their actual goals and abilities (development of a more realistic self-concept) (Baumert & Köller, 1998; Todt, 1990).

Whereas there are several studies concerned with elementary and secondary education, the research on tertiary education is sparse. We know relatively little about the development and conditions of motivational variables at university. So far, only a few longitudinal studies were conducted (e.g., Fazole & Fazole, 1998; Lewalter, 2002). Yet, we believe that it is also highly relevant for higher education to find out how especially intrinsic motivation, which supports learning, can be increased or at least sustained, so that students can identify with their course of studies.

Based on the "academic motivation scale" (Vallerand et al., 1992), Fazole and Fazole (1998) assessed university students in a two-year longitudinal study and discovered a surprisingly high level of stability for the sub-scales of intrinsic and extrinsic motivation. Overall, the results showed a higher level of intrinsic motivation and identification with education goals, compared to extrinsic motivation. Only very few students were amotivated. However, Fazole and Fazole's research could not derive information about the conditions of the high stability of motivational variables. It appears to be generally problematic for longitudinal studies to learn more about the conditions of learning motivation. Therefore, only a few variables have been identified so far concerning the influence on learning settings at schools and universities, which could explain the dynamics of non-cognitive learning motivation.

This paper investigates the dynamics of learning motivation in higher education and the conditions of students' learning motivation. It is based on Deci and Ryan's (2002) self-determination theory (SDT), which has shown to be of high relevance for the study of learning motivation: it provided the foundation for research at school (e.g., Ryan, Connell, & Grolnick, 1992), in vocational training (e.g., Prenzel, Kramer, & Drechsel, 2001; K.-P. Wild & Krapp, 1996) or at university (Levesque, Zuehlke, Stanek, & Ryan, 2004; Lewalter, 2002; Müller & Louw, 2003, 2004; Williams & Deci, 1998).

In comparison to other theories of motivation the self-determination theory allows a differentiated analysis of the quality of learning motivation and postulates three basic psychological needs as conditions for the development of

intrinsic (self-determined) motivation. The basic needs for autonomy, competence, and social relatedness showed to be relevant conditions of learning motivation in educational settings (see below).

The SDT have so far been confirmed in studies in the USA and Europe, as well as in Japan and Russia (see Chirkov & Ryan, 2001; Deci & Ryan, 2002), South Africa (Müller & Louw, 2004) or Bulgaria (Deci et al., 2001). In Eastern Europe a longitudinal study has not yet been conducted to explore the learning motivation and its conditions inside or outside educational institutions. However, recently a few cross-sectional analyses of higher education in Croatia were introduced, which were based on the SDT (Müller & Palekčić, 2005; Palekčić & Müller, 2004; Palekčić, Radeka, Petani, & Müller, 2004).

With these findings concerning the Croatian higher education system we designed a three year longitudinal research. Its results are presented in this paper. The goal of this article is (a) to gain information about the stabilities and instabilities of learning motivation processes at university, and (b) to determine the significance of perceived basic needs in teaching-learning environment for the learning motivation at university. We will first provide an outline of the self-determination theory, before discussing its relevance for educational sciences.

The self-determination theory (SDT)

The classic distinction between intrinsic and extrinsic motivation (Deci, 1975), provided the basis for Deci and Ryan's (2002) development of the so-called self-determination theory (SDT). According to Deci and Ryan, intrinsically motivated behavior represents the prototype of self-determined behaviors and as such can be described as "wholly volitional, as representative of and emanating from one's sense of self" (Deci & Ryan, 1994, p. 5). Intrinsically motivated behavior is associated with curiosity, exploration, spontaneity and interest. In contrast, extrinsically motivated behaviors are undertaken to attain an end state that is separate from the actual behavior. The motive hence is determined by external contingencies.

Many studies have treated intrinsic and extrinsic motivation as binary oppositions. The SDT, however, provides a differentiated understanding of motivation. A dichotomous conception of intrinsic and extrinsic motivation results in simplifying analyses and research findings point out that there are forms of extrinsically motivated behavior, which can be self-determined. A student of economics, for example, can enjoy his studies, can be very interested and can perceive himself as self-determined (and hence be intrinsically motivated), yet at the same time grades and his future professional status might also be important to him.

Deci and Ryan (2002) therefore developed a concept that analyses extrinsic and intrinsic motivation not categorically,

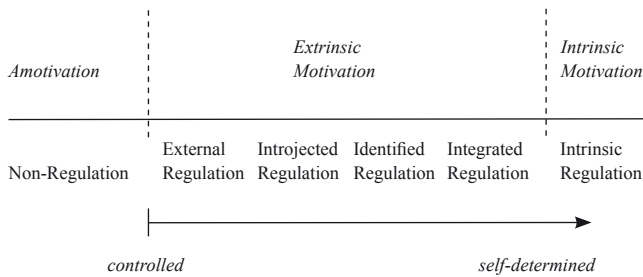

Figure 1. The continuum of self-determination (Deci & Ryan, 2002, p. 16)

but instead places them on a continuum from controlled to autonomous regulation (see Figure 1). They differentiate four regulatory styles of extrinsic motivation that vary in their degree of self-determination and the level of integration of values and norms into the 'autonomous self'. Here, the autonomous self is conceptualized as the core element of personality, the central control dimension, which represents an essential aspect of a person's identity.

The figure shows the continuum of self-determination and reveals that the regulatory styles range from controlled to self-determined.

Depending on the degree of autonomy, the continuum of self-determination differentiates between (1) amotivated behavior, (2) four regulatory styles of extrinsic motivation and (3) intrinsic motivation, as self-determined regulated motivation (Deci & Ryan, 2002):

Amotivated: Amotivation shows non-regulation and according to the SDT cannot be described as motivated behavior, because it is not task-oriented. Deci and Ryan (1994) speak of motivated behavior only if it is an intentional activity. Amotivated behavior refers to activities such as snoozing, relaxing or random channel-hopping.

External regulation: This kind of regulation depends on external contingencies, for example, to attain a reward or likewise avoid negative feedback. External regulation can be described as the 'classic' extrinsic motivation (see above).

Introjected regulation: Introjected regulation includes actions aimed at contingencies that relate to one's self-esteem. This could mean that a person studies in order to impress others, or because it is 'right and proper' to act in a certain way. The cause of action may come from the person him/herself, yet is hardly self-determined. It is external to the persons' sense of self. An example would be: a student attends a class only because otherwise she/he would have a bad conscience or because she/he believes that this is the right thing to do for a 'good' student. Hence, the student has internalized external expectations and the action control has moved from 'without' to 'within'. However, this form of

regulation is still extrinsically motivated, because it shows a low level of self-determination.

Identified regulation: Here, the focus is on the personal relevance of an action. For example: a learner identifies with the values and aims of his studies and integrates them into his/her self. She/he might not be interested in a certain subject, but nevertheless the final exams and graduation are of personal relevance. The SDT believes that the learner in this case regulates his behavior according to his/her identification with long-term targets, such as his/her degree.

Integrated regulation: More than any form of external regulation, integrated regulation depends on self-determination. It integrates identified values into the coherent sense of self. These values coexist harmoniously along other aspects of the self (Deci & Ryan, 1994, pp. 6-7). This regulatory style is close to intrinsic, self-determined regulation and it is difficult to differentiate empirically between intrinsic and integrated motivation. Hence, in our empirical study this regulatory style has not been considered.

However, the continuum of self-determination also describes a developmental dimension: Controlled regulations can be transformed into self-determined forms of regulation through internalization and integration processes. This is what makes this theory so interesting for educational sciences. Values and norms can be internalized and finally even integrated into the autonomous self. This describes a transformation process from external to internal. The individual him/herself is responsible for this integration, while a certain environmental context, which involves personal meaning and emotional valence, can enhance or thwart the integration (see below).

The SDT is of pedagogic relevance not only regarding the quality of learning processes and learning results, but it provides important implications on decisive motivational aspects for the learning settings, as well.

According to the SDT (Deci & Ryan, 2002), the transformation of external regulation into self-determined forms of regulation, as well as the stability of self-determined (intrinsic) motivation depends on three aspects (Black & Deci, 2000; Deci, Ryan, & Koestner, 1999; Williams & Deci, 1998): The satisfaction of the basic, innate psychological needs for *support of autonomy*, *support of competence*, and *social support*. In contrast to other theories of needs, Deci and Ryan postulate purely psychological basic needs, which they regard as universal. In this sense, the term basic need cannot be substituted by the term motive. Motives are inter-individually varying action goals, whereas "... basic needs are universal - that is, they represent innate requirements rather than acquired motives. As such, they are expected to be evident in all cultures and in all development periods." (Deci & Ryan, 2002, p. 7). Basic needs now are significant, because activities which appear at first sight uninteresting (the person is therefore not intrinsically motivated) can be

internalized into the autonomous self and finally even integrated, if the support of autonomy, competence and social relatedness is successful. Yet, the significance of the three basic needs for the explanation of action and experience can vary depending on the situation and the cultural context (Deci & Ryan, 2000).

Support of Autonomy: The theoretical concept of the need for autonomy has been repeatedly misinterpreted and used synonymously with independence. In accordance with the SDT, autonomy has to be considered as a perceived consistency between inner values, what one wants, and the perceived environment. The opposite of autonomy, therefore, is not dependence, but heteronomous control, i.e. an inner conflict between goals and experiences, between interests as well as between personal values. Following the SDT, a person is autonomous “when his or her behavior is experienced as willingly enacted and when he or she fully endorses the actions in which he or she is engaged and/or the values expressed by them” (Chirkov, Ryan, Kim, & Kaplan, 2003, p. 98). This means, it is quite possible that a person is highly dependent (the opposite of independence) on others, yet still perceives him/herself as autonomous in the sense of the SDT. In this case, the reason is that the person experiences the norms and values of societies or groups as congruent with his/her self.

Support of competence: The support of competence refers to instructional aspects, such as informative feedback, helpful advice provided by the lecturers or the perceived ‘fit’ of study requirements etc. (see below). If a person has the impression that she/he can benefit from and grow in a certain situation, this enhances the long-term processes of internalization and integration and thereby influences the development or stability of intrinsic motivation.

Social support: Deci and Ryan further postulate that the integration of external motivation is supported by an interpersonal interaction (with significant others such as parents, teachers, his/her boss etc.) or interaction with groups (“social relatedness”). In other words, intrinsic motivation will increase with a positive perception of the social (learning) environment, when individuals are being taken seriously, which in turn leads to the feeling of being part of a group.

This natural tendency of transformation of external regulation into self-determined regulation makes the theory particularly interesting for educational research (see e.g., Deci & Ryan, 1994; Deci et al., 1991; Reeve, 2002). The quality of motivation, however, does not only depend on the learning environment. Rather, it has to be viewed as an interdependent function of the individual and the environment. For example, personal goals and interests are of importance, too. Thus, the quality of the learning motivation is always the result of the relation between a person and his/her environment.

METHOD

Study design

As illustrated in Figure 2, the longitudinal study compares the motivation, as postulated by Deci and Ryan, as well as the basic needs for autonomy, competence and social relatedness at three time points. This design allows us to analyze the relations between motivational regulatory styles and the basic needs at the respective time points. Furthermore, it is investigated how learning motivation corresponds with the basic needs at the three different stages. Following the assumptions of the SDT perceived basic needs should be positively correlated with self-determined regulatory styles (intrinsic and identified) and negatively with external regulation or amotivation. We expect a zero correlation for the association between basic needs and the introjected regulatory style.

The analysis, hence, focuses on two lines. First, we examine the basic needs at the three time points as independent variables and the motivation as dependent variables (solid lines). However, it is possible that the regulatory styles of motivation preform the perception of the support of the basic needs. Therefore, we have to analyze in a second step a model which views the basic needs as mediating variables between the learning motivations (dashed lines).

Furthermore, it has to be pointed out that the psychological basic needs – depending on the setting – may also intercorrelate and therefore cannot be regarded as independent concepts (Deci & Ryan, 2002). It is plausible, for instance, that the perceived autonomy in a learning setting is linked to the perceived possibility to increase one’s skills and competences (support of competence). For example, studies of learning environments observed that a positive perception of the social climate does not only foster the academic and social self-concept, but also increases the students’ competence beliefs (Eder, 2002).

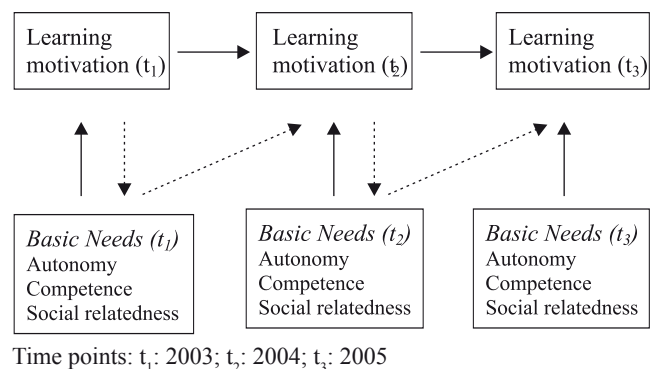

Figure 2. Design of the longitudinal analysis

Instruments

In the following, the variables are listed and for a better comprehensibility a few item examples are introduced:

The instrument for the assessment of learning motivation is based on a questionnaire by Vallerand and others (Vallerand et al., 1992). The questionnaire for the perceived basic needs follows Prenzel (1996), as well as Müller and Louw (2003). The items were formulated to refer explicitly to the learning situation in the students' major subject².

The first version of the assessment instrument was translated from English into Croatian. To prevent translation inaccuracy, as well as potential difficulties in understanding the items, the Croatian version was then re-translated into English and a few lingual adjustments of some items were made (see Müller & Palekčić, 2005; Palekčić & Müller, 2004).

Extrinsic motivational styles (following Vallerand et al., 1992):

- 1.) Amotivation (3 items, Alpha: .79)
 - "I am very uncertain whether I have chosen the proper field of study."
- 2.) External regulation (3 items, Alpha: .65)
 - "Without pressure from outside I would do less."
- 3.) Introjected regulation (2 items, Alpha: .63)
 - "I do my work, because it is the right and proper thing for a good student to do."
- 4.) Identified regulation (2 items, Alpha: .73)
 - "I am committed in my studies, because I want to realize the goals I set myself."
- 5.) Intrinsic motivation (3 items, Alpha: .89)
 - "I find that learning here is really exciting."

Perceived basic needs, relating to learning at university (see also, Prenzel, 1996):

- 1) *Support of autonomy* (3 items, Alpha: .78)
 - "It is possible to organize the studies in accordance with one's own ideas and interests."
- 2) *Support of competence* (3 items, Alpha: .78)
 - "The advice provided by the lecturers is very helpful for my own learning process."
- 3) *Social support* (4 items, Alpha: .74)
 - "The lecturers do actually not take care of the students' interests." (-)

Participants

In 2003, 2004 and 2005, the forms were presented to 724 students of Humanities and Social Sciences at the Univer-

sity of Zadar (Croatia). A sample of 104 students provided complete data over the three years and was used in the longitudinal study. These students had a mean age of 20 years, and the majority was female (80%). In 2003, almost all of them (95%) were in their first year at university. A majority of 87% were able to actually enroll for the course of studies they desired, compared to 13% who had to decide on another course of studies. For all time points, no significant differences on any scale were found between the final 104 participants and 620 students from the cross sectional study ($N=724$: overall; $n=104$: longitudinal study).

Procedure

The students completed the questionnaires during a scheduled lecture period. Students were told that the participation is voluntary and they were assured that their data would remain anonymous. The questionnaires were completed under the supervision of an experienced researcher. To be able to guarantee the correct assignment of a questionnaire at the three time points to the respective case, we introduced a 4 figure code and thereby ensured a definite assignment for all cases.

Data analysis

Besides descriptive statistics we used structural equation modeling (Byrne, 2001) to test the relations between basic needs and the motivational qualities at the three time points. The statistical analysis was conducted with the Amos 4.0 program (Arbuckle, 2003).

RESULTS

Overall, the students show clearly stronger autonomous than controlled motivation for all three time points. This can be summarized by the so-called self-determination index (SDI) (Levesque et al., 2004; Vallerand, 1997), which is calculated as follows:

$SDI = (2 \times \text{intrinsic motivation}) + \text{identified regulation} - \text{introjected regulation} - (2 \times \text{external regulation})$.

The self-determination index can reach a maximum score of +12 and a minimum score of -12. The SDI can therefore summarize self-determined motivation (positive scores) or controlled regulation (negative scores). The index was calculated separately for all three time points and remained relatively stable over the three years (see Table 1).

If we take a closer look now at the specific regulatory styles in a longitudinal analysis, we can observe a high stability of the scales over the period of three years (see Table 1). The students are hardly amotivated and their score for external regulation lies below the middle of the scale. Further, the group can be described as clearly introjectedly

² For a full version of the questionnaire please contact the authors.

regulated or intrinsically motivated. In general, those identified with the study targets score highly on the scale.

In addition, Table 1 indicates that identified regulation as well as intrinsic motivation significantly decreases in 2004 (significant variation between t_1 and t_2 for both variables), but that we can no longer find significant differences between the first and the third year. One reason for the decrease of identified regulation and intrinsic motivation can be seen in the students' focus on examinations. In fact we found higher scores for the item "I am learning primarily for the examinations" for second year students than for first year students (first year $M = 3.26$, $SD = 1.04$; second year $M = 3.49$, $SD = 1.09$; $t(93) = 2.41$, $p < .05$).

We found significant differences in intrinsic motivation in the year of 2003 between those students who enrolled the studies they desired and those who could not ($n=10$). Students who would have preferred to study something else are less intrinsically motivated ($M = 3.24$, $SD = 0.30$) than students who were able to study their desired subject ($M = 3.56$, $SD = 0.90$; $t(101) = 2.98$, $p < .02$). As for the gender differentiation, the only significant difference was found on scores for introjected regulation (2005), with women scoring higher ($M = 3.49$, $SD = 0.86$) compared to the male students ($M = 2.43$, $SD = 0.53$). However, this result can

only be taken as a tendency, because women were clearly over-represented in this sample.

In general, the motivational regulatory styles remained relatively stable over the three years. Over the years, the perceived support of autonomy and competence gradually shows a significant decline (see Table 2). The decrease for the support of autonomy and competence between the second and the third year is particularly high (autonomy: $t(99) = 2.73$, $p < .01$; competence: $t(100) = 2.53$, $p < .02$). We can assume that the students' need for autonomy grows during their years of education and that they long for more support from their lecturers than they actually get in their third year at the Croatian university. It is also possible that the students develop a more critical perspective on the teaching-learning environment over the years. The social relatedness regarding the quality of relations between the students, as well as between students and lecturers, remains stable on a high level (cf. Table 2).

Social relatedness also appears as the dominant variable in the longitudinal study. But in the third year, we also found significant correlation of the perception of autonomy ($r = .25$, $p < .05$) and competence ($r = .31$, $p < .01$) with the SDI, although the scores for the support of autonomy and competence have clearly decreased for the third year at university (Figure 3).

By use of path analysis, we aimed to find out how the relation between the basic needs and the motivation can be presented in a longitudinal model. We started by calculating a basic model, which models a path for the SDI for all three

Table 1

Descriptive statistics of the motivational variables ($n=104$)

	(2003)		(2004)		(2005)	
	M_1	SD	M_2	SD	M_3	SD
Amotivation	1.58	0.75	1.62	0.75	1.60	0.86
External	2.73	0.94	2.71	0.92	2.68	0.85
Introjected	3.46	0.78	3.54	0.81	3.37	0.86
Identified	4.41	0.65	4.17	0.72	4.28	0.84
Intrinsic	3.52	0.85	3.29	0.90	3.50	0.84
Self-determination index (SDI)	2.50	3.13	1.79	3.46	2.56	3.49

Note. Scales: 1= disagree, 5= agree (does not apply to SDI!); After a confirmatory factor analysis, the items of motivation (not including SDI) present a clear four-factor solution and together explain 71% of the variance. The items of the scales "Amotivation" (minus sign) and "Intrinsic Motivation" (plus sign) are loading on the same factor. So we can assume that there exists a five factor structure.

Table 2

Descriptive statistics of perceived learning environment: basic needs ($n=104$)

	(2003)		(2004)		(2005)	
	M_1	SD	M_2	SD	M_3	SD
Support of autonomy	3.19	0.84	2.99	0.83	2.58	0.86
Support of competence	3.50	0.80	3.36	0.81	3.05	0.76
Social relatedness	3.64	0.67	3.61	0.73	3.68	0.72

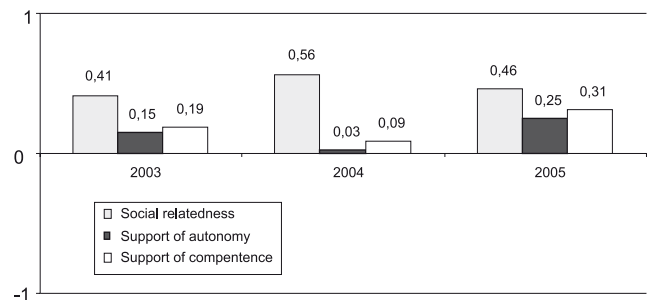

Figure 3. Pearson correlations between perceived basic needs and self-determination index (SDI), from a longitudinal perspective ($n=104$)

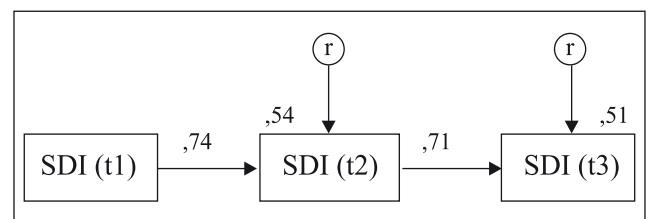

Figure 4. Path diagram for self-determination index (SDI) ($t_1 - t_3$)

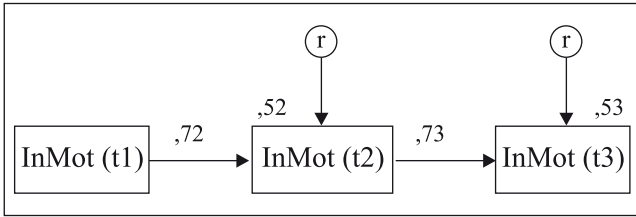

Figure 5. Path diagram for intrinsic motivation (InMot) ($t_1 - t_3$)

time points. The results again confirm the stability of self-determined motivation (Figure 4). The SDI (t_1) accounts for 54% of the variance of SDI (t_2) and 51% of the SDI (t_3) can be explained. The fit of this first model is relatively good ($\chi^2(1, N = 104) = 3.0, p = n.s.; CFI=0.98$). This means that it is very likely that students who are autonomously motivated at the beginning of their studies will remain so in their second and third year at university.

For the different styles of regulation according to the self-determination theory (external regulation, introjected, identified and intrinsic motivation) we also find good fit indexes (CFI) between 0.985 and 1.00 (see for example for intrinsic motivation: Figure 5; $\chi^2(1, N = 104) = 0.62, p=n.s.; CFI=1.00$). An exception here is the introjected regulation for which a satisfactory fit in the longitudinal study was not obtained ($\chi^2(1, N = 104) = 4.11, p=.04; CFI=0.82$).

The central aim of this analysis is to draw conclusions about how the basic needs can additionally explain self-determined motivation in a longitudinal investigation. This can be achieved by an examination of a diagram, which considers the three basic needs for autonomy, competence and social relatedness at the three time points.

When the three basic needs at the respective time point were integrated into the path diagram (see Figure 6), no satisfactory fit for the model was found ($\chi^2(46, N = 104)=139, p < .001; CFI=0.77$). Furthermore, only social relatedness achieved significant path indexes ranging from .15 to .44 for all three time points (t_1 to t_3). At no time point, the support of autonomy and competence can be identified as significant for the SDI. The three basic needs intercorrelate between the time points on a medium to high level (between .36 and .78). 20% of the variance of the self-determination index (SDI (t_1)) can be explained, as well as 60% of the SDI (t_2) and 51% of the SDI (t_3). Compared to the basic model (Figure 6) the explanation for the variance of the SDI increases in the second year (SDI (t_2), rising 6% from $R^2=.54$ to $R^2=.60$). The variance for SDI (t_3) could not be improved by the model which integrates all three basic needs.

With the findings of this path analysis (Figure 6), social relatedness shows a strong prediction for the analysis of self-determined motivation at all three time points. We found reasonable, therefore, to examine a model which focuses singularly on social relatedness (see Figure 7). The

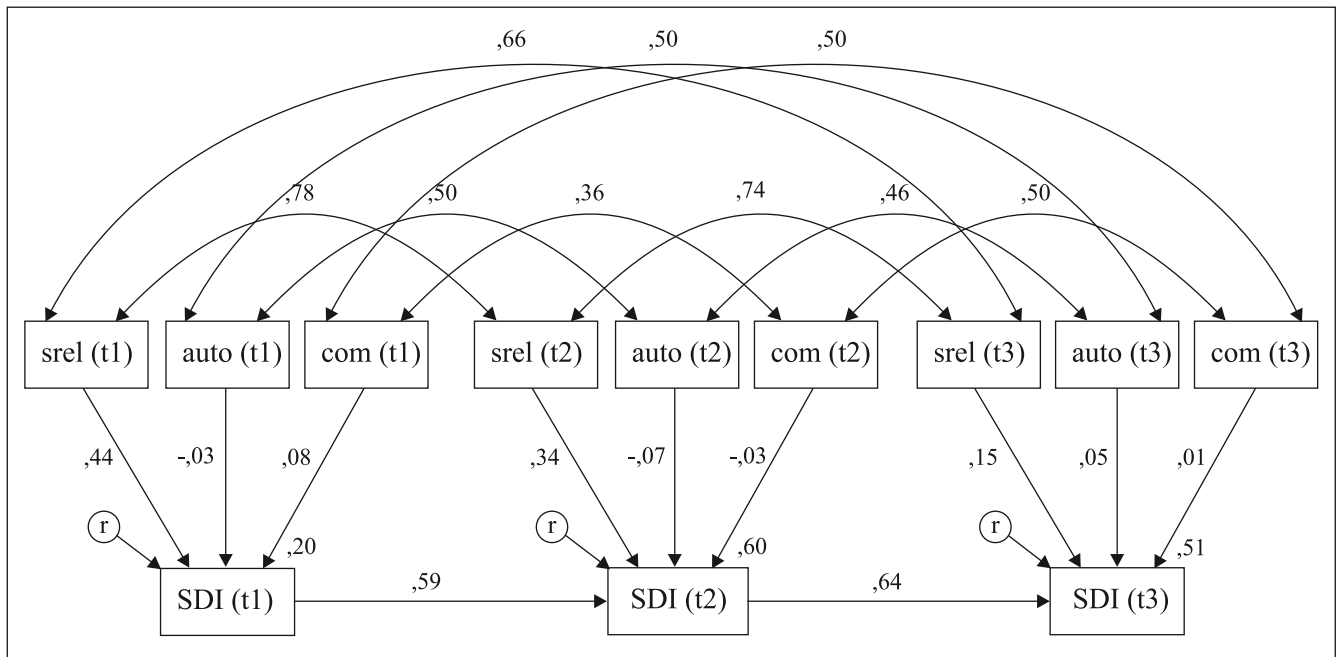

Figure 6. Path diagram with SDI and basic needs

Note. SDI = self-determination index; auto = perceived support of autonomy; com = perceived support of competence; srel = perceived social relatedness.

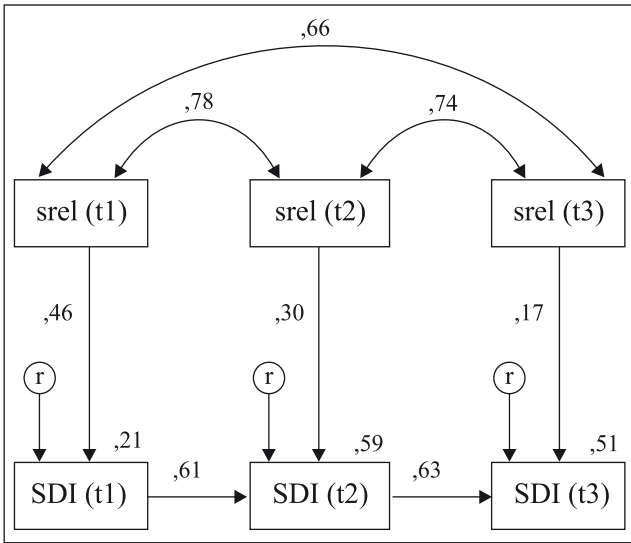

Figure 7. Path model with SDI (t_1 to t_3) and social relatedness (t_1 to t_3)

Note. SDI = self-determination index; *srel* = perceived social relatedness (4 items).

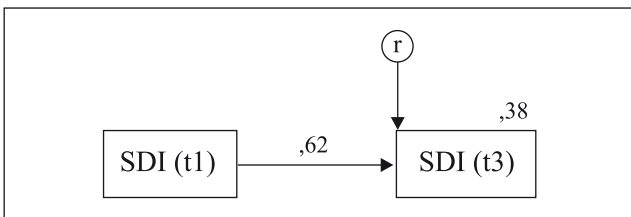

Figure 8. Basic path model with SDI (t_1 and t_3)

Note. SDI = self-determination index (t_1 and t_3).

new model provides a good fit index ($\chi^2(7, N = 104) = 11.1, p = .n.s.; CFI=0.98$). 21% of the variance of the self-determination index (SDI (t_1)) can be explained, 59% of the SDI (t_2) and 51% of the SDI (t_3). The path coefficients of social relatedness to the SDI are significant at all three time points. Yet, in the third year (t_3) the scores of social relatedness for the explanation of the self-determination index (t_3) is lower (.17). Over the years, the relevance of social relatedness for the explanation of self-determined motivation decreases. However, this can be explained by the fact that social relatedness remains relatively stable over the period of time (see intercorrelations in Figure 7) and therefore does not provide additional explanation for the self-determination index (t_3).

Furthermore, the paths from *srel* (t_1) to SDI (t_2), as well as the path from *srel* (t_2) to SDI (t_3) were examined (see also the dashed lines in Figure 2). However, this did not produce additional explanation or significant path coefficients.

In the models presented above, perceived social relatedness was conceived as a condition of self-determination. Therefore, the arrows in the path model point from social relatedness to the SDI. From a theoretical perspective, however, it is quite possible that the SDI influences the basic needs. Students who show a high level of self-determined motivation at the beginning of their studies should perceive their relations to fellow students or lecturers more positively than students with a low level (see Lewalter, 2002). In this sense, social relatedness becomes the mediating variable between self-determination for example in the first and the third year at university. Figure 8 illustrates that the self-determination index (t_1) can explain 38% of the variance of the SDI (t_3).

Social relatedness is now introduced into the model as a latent variable (social relatedness at all three time points) in the sense of a mediating variable (Figure 9). The model reaches a very good fit index ($\chi^2(3, N = 104) = 2.36, p = .n.s.; CFI=1.00$) and illustrates that overall 40% of the SDI (t_3) can be explained. Thus, the perceived 'social relatedness' presents a significant predictor for self-determined motivation. This means that students who perceive themselves as socially integrated during their time at university show a higher degree of self-determined motivation at the end of their studies than their fellow students with a lower level of social relatedness. Students who are already highly self-determined motivated at the beginning of their studies will also have a more positive perception of their social environment during their years at university and it is therefore easier for them to maintain or even increase the quality of their

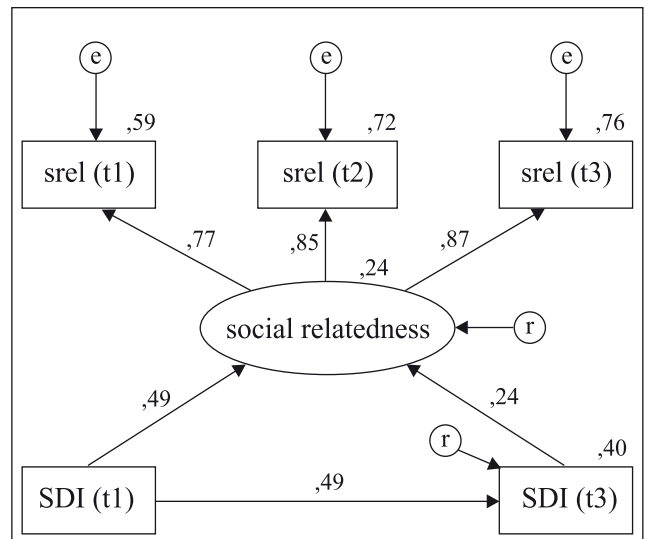

Figure 9. Path model with SDI (t_1 and t_3) and social relatedness

Note. SDI = self-determination index (t_1 and t_3); *srel* = perceived social relatedness (*srel* (t_1)) to *srel* (t_2)).

motivation. This is indicated in Figure 9, where the SDI (t_1) can explain 24% of the social relatedness during the course of studies. The significant path coefficient between SDI (t_1) and social relatedness amounts to .49, just as the coefficient between SDI (t_1) and SDI (t_3).

In general, the path models reveal that self-determined motivation remains relatively stable over the period of three years. Only social relatedness provides a significant contribution to the assessment of self-determined motivation. The basic needs, support of autonomy and support of competence, are not relevant for the motivational regulation in this longitudinal study. Social relatedness acts as mediating variable, but also provides its own explanation for the self-determination index.

DISCUSSION AND CONCLUSION

The aim of this paper was to describe self-determined motivation in a three-year longitudinal study and to analyze the significance of the basic needs in this relation.

The results indicated that the participants were highly intrinsically motivated and they showed a higher score for introjected and identified regulatory styles compared to external regulation. Particularly high scores were obtained for identified regulation, whereas the perceived amotivation was very low in all three time points. These findings for perceived motivational qualities indicate overall good conditions for high quality learning. On average, the students can be described as highly identified with the goals and contents of their respective course of studies.

From a longitudinal perspective, the motivational regulatory styles show a high stability over the three years. Only intrinsic motivation and identified regulation slightly decrease between the first and the second year. One reason for this result can be seen in students' focus to examinations. A hint for this interpretation can be found in the means for the item "I am learning primarily for the examinations" in the first and second year of study (first year: $M = 3.26$; second year: $M = 3.49$). In the third year, however, the mean scores of these two regulatory styles tend to increase again.

At the beginning of this study it was pointed out that for educational institutions it is more likely to observe a decline of intrinsic or self-determined motivation and subject-related interest. However, this did not prove to be the case for the students at the Croatian university. Fazey and Fazey (1998) already showed that the qualities of motivation can remain relatively stable over the years at university.

According to Deci and Ryan's SDT, the stability or instability of motivational processes should depend upon the satisfaction of the basic needs. Our analysis could only confirm the relevance of social relatedness for the explanation of the self-determination index. Social relatedness appears as mediating variable, but also provides its own explanation for self-determination in the third year at university. It is

therefore an important condition for the motivational regulation of the students at the University of Zadar.

Why our findings do not show a correspondence between the support of autonomy and competence and self-determined motivation, as the SDT's hypotheses predicts? Similar findings also appeared in a cross-sectional analysis (see Müller & Palekčić, 2005). Furthermore, the perceived support of autonomy and competence decreased significantly in the second and third year at university. Yet, the decline of these two perceived basic needs proved to be insignificant in the structural equation model for the students' motivation. This comes as a surprise particularly for the support of competence in the field of education, where the development of competence is emphasized. How can these findings now be interpreted?

One possible explanation could be derived from the fact that on average motivational orientations stabilized on a relatively high level. The students' subject choice is mainly influenced by their own personal interests (Bargel, Ramm, & Multrus, 2001; Krapp, 1997; Palekčić & Müller, 2004) and we can therefore assume that the motivation remains stable relatively independently from the teaching-learning environment. For the Croatian sample this effect may be even stronger, because 87% of the participants were able to study the course of studies they desired. It is also important to consider the fact that to study at university is still a privilege in Croatia and only 7% of an age-cohort actually enrolls at university. It is very likely that this contributes to the high level of motivation at the beginning of the studies and its stability, although the conditions of the environment are not always perceived as very positive (cf. autonomy and competence).

We believe it is also important to consider that the low statistical relevance of the perceived environment (support of competence and autonomy) for motivational processes on a summative level does not necessarily mean that the study environment hardly influences motivation. Several experimental studies show that the opposite, namely the limitation of the support of autonomy and competence, undermines existing self-determined motivation (e.g., Deci & Ryan, 2000; Deci et al., 1999; Prenzel, 1997). To gain more knowledge about this context it is important to conduct more ecological experiments. They could for instance analyze the effects of deliberate changes of the learning environment on motivation.

The importance of social relatedness for the motivation of the Croatian students could also be interpreted on the basis of cultural differences. It has been much disputed whether autonomy is of relevance only in individualistic Western societies and is of low or no relevance in more collectivistic societies. This would entail a fundamental criticism of the hypothesis that basic needs are of universal significance for the regulation of actions and experiences. In particular, the basic need of autonomy has been repeatedly challenged and

its critics pointed at intercultural differences (Lepper et al., 2002; Lepper, Henderlong, & Iyengar, 2005; Miller, 1997).

Deci and Ryan strongly object their critics and emphasize the importance of defining the term autonomy (see above). They do not use autonomy synonymously with independence or individualism. Rather, the SDT places autonomy in an orthogonal relation to independence and individualism. We believe it would be premature for such a theoretical fundamental criticism on the basis of the data obtained. First it has to be tested if an experimental enhancement of the range of autonomy at university or the improvement of arrangements for the support of competence will actually lead to changes of the students' motivation.

Furthermore, it needs to be clarified whether the differences between academic disciplines could be more relevant than general cultural differences. It is quite possible that only the participating students of Humanities and Social Sciences perceived social relatedness as more relevant than autonomy. A study of students of Natural Sciences or Engineering in South-Eastern Europe has yet to be conducted.

On the one hand it has to be mentioned that the means of the 104 students analyzed in the longitudinal study are relatively similar with the results of the cross-sectional analysis ($N = 724$). On the other hand it is difficult to generalize the results of our longitudinal study due to the relatively high gender homogeneity. As already shown, the participants were exclusively students of Humanities and Social Sciences. It also has to be considered that the data refer to the perceptions of the entire course of studies, therefore allowing no differentiation between subjects or individual lectures. Yet, here we should also find considerable variations of motivation and its conditions.

In our opinion, the assessment of motivational processes should pursue the following research approaches. First, the research designs need to integrate further, person-related variables in addition to the basic needs. These could refer to the personality of the students (see e.g., Müller & Louw, 2003; Palekčić & Müller, 2004), to individual strategies concerning studying and coping with demands or biographical aspects of motivational orientation (e.g. family-orientated variables; Wild & Hofer, 2000). Longitudinal analyses, which have been rarely conducted, are to be favored. Second, it is important to conduct more specific studies regarding the different subjects. These would incorporate for instance variations of different teaching styles, consulting contexts or examination traditions. Furthermore, aspects of individual lectures and classes can be integrated in this context (see e.g., Lewalter, 2002, Prenzel, et al., 1993). Third, it is important to consider the traditions and variations of internal teaching and learning environments before interpreting the results as general cultural differences.

Finally, we need to assume that socio-political or socio-economic aspects influence the learning motivation and the interest in education directly or indirectly (Dörnyei,

1994; Ferrari & Mahalingam, 1998; Guay & Vallerand, 1997; McInerney & Etten, 2001; Noels, 2001). It is therefore necessary to identify these conditions and to consider them in empirical designs. Overall, we believe it is important to focus on various motivation-relevant issues in the design of future research concerning learning motivation: on the person him/herself, on the learning environment, on the general structural and administrative conditions of the institution and on external social conditions. This seems to be the adequate way to identify the practical possibilities and limitations of the support of motivation – not only for higher education.

REFERENCES

- Anderman, E., & Maehr, M. L. (1994). Motivation and Schooling in the Middle Grades. *Review of Educational Research*, 64, 287-309.
- Arbuckle, J. L. (2003). *Amos 5* (Computer software). Chicago: SmallWaters.
- Baker, S. R. (2003). A prospective longitudinal investigation of social problem-solving appraisals on adjustment to university, stress, health, and academic motivation and performance. *Personality and Individual Differences*, 35, 569-591.
- Bargel, T., Ramm, M., & Multrus, F. (2001). *Studiensituation und studentische Orientierungen* [Conditions of studying and students' orientation]. Bonn: Bundesministerium für Bildung und Forschung.
- Baumert, J., & Köller, O. (1998). Interest research concerning secondary level I: An overview. In L. Hoffmann, A. Krapp, K. A. Renninger & J. Baumert (Eds.), *Interest and learning: Proceedings of the Seeon-conference on interest and gender* (pp. 241-256). Kiel: IPN-Schriftenreihe.
- Black, A. E., & Deci, E. L. (2000). The Effects of instructors' autonomy support and students' autonomous motivation on learning organic chemistry: A self-determination theory perspective. *Science Education*, 84, 740-756.
- Byrne, B. M. (2001). *Structural equation modeling with Amos*. Mahwah: Lawrence Erlbaum Associates, Publishers.
- Chirkov, V. I., & Ryan, R. M. (2001). Parent and teacher autonomy-support in Russian and U.S. Adolescents. Common effects on well-being and academic motivation. *Journal of Cross-Cultural Psychology*, 32, 618-635.
- Chirkov, V. I., Ryan, R. M., Kim, Y., & Kaplan, U. (2003). Differentiating autonomy from individualism and independence: a self-determination theory perspective on internalization of cultural orientations and well-being.

- Journal of Personality and Social Psychology*, 84, 97-110.
- Deci, E. L. (1975). *Intrinsic motivation*. New York: Plenum Press.
- Deci, E. L., & Ryan, R. M. (1994). Promoting self-determined education. *Scandinavian Journal of Educational Research*, 38, 3-14.
- Deci, E. L., & Ryan, R. M. (2000). The "what" and "why" of goal pursuits: Human needs and the self-determination of behavior. *Psychological Inquiry*, 11, 227-268.
- Deci, E. L., & Ryan, R. M. (2002). Overview of self-determination theory: An organismic dialectical perspective. In E. L. Deci & R. M. Ryan (Eds.), *Handbook of self-determination research* (pp. 3-33). Rochester: University of Rochester Press.
- Deci, E. L., Ryan, R. M., Gagné, M., Leone, D. R., Usunov, J., & Konrathzheva, B. P. (2001). Need satisfaction, motivation and well-being in the work organization for a former Eastern Bloc country. *Personality and Social Psychology Bulletin*, 27, 930-942.
- Deci, E. L., Ryan, R. M., & Koestner, R. (1999). A meta-analytic review of experiments examining the effects of extrinsic rewards on intrinsic motivation. *Psychological Bulletin*, 125, 627-668.
- Deci, E. L., Vallerand, R. J., Pelletier, L. G., & Ryan, R. M. (1991). Motivation in education: The self-determination perspective. *Educational Psychologist*, 26, 325-346.
- Dörnyei, Z. (1994). Motivation and motivating in the foreign language classroom. *Modern Language Journal*, 78, 273-284.
- Eder, F. (2002). Unterrichtsklima und Unterrichtsqualität [Educational climate and quality]. *Unterrichtswissenschaft*, 30, 213-228.
- Fazey, D., & Fazey, J. (1998). Perspectives on motivation: The implications for effective learning in higher education. In S. Brown, S. Armstrong & G. Thompson (Eds.), *Motivating students* (pp. 59-72). London: SEDA: Staff and Educational Development Series.
- Ferrari, M., & Mahalingam, R. (1998). Personal cognitive development and its implications for teaching and learning. *Educational Psychologist*, 33, 35-44.
- Gottfried, A. E., Fleming, J., & Gottfried, A. W. (2001). Continuity of academic intrinsic motivation from childhood through late adolescence: A longitudinal study. *Journal of Educational Psychology*, 93, 3-13.
- Guay, F., & Vallerand, R. J. (1997). Social context, students' motivation and academic achievement: Towards a process model. *Social Psychology of Education*, 1, 211-233.
- Hardt, B., Zaib, V., Kleinbeck, U., & Metz-Göckel, H. (1996). Unterrichtsziele und Lernmotivation im Kontext kaufmännischen Unterrichts [Aims of teaching and learning motivation in context of mercantile education]. *Unterrichtswissenschaft*, 16, 235-249.
- Harter, S. (1981). A new self-report scale of intrinsic versus extrinsic orientation in the classroom: Motivational and informational components. *Developmental Psychology*, 17, 300-312.
- Helmke, A. (1993). Die Entwicklung der Lernfreude vom Kindergarten bis zur 5. Klasse [Development of learning motivation from kindergarten to fifth grade]. *Zeitschrift für Pädagogische Psychologie*, 7, 77-86.
- Krapp, A. (1992). Das Interessenkonstrukt. Bestimmungsmerkmale der Interessenhandlung und des individuellen Interesses aus der Sicht einer Person-Gegenstands-Konzeption. In A. Krapp & M. Prenzel (Eds.), *Interesse, Lernen, Leistung* (pp. 297-329). Münster: Aschendorf.
- Krapp, A. (1997). Interesse und Studium [Interest and study]. In H. Gruber & A. Renkl (Eds.), *Wege des Könnens* (pp. 45-58). Bern/Göttingen: Huber.
- Krapp, A. (1998). Entwicklung und Förderung von Interessen im Unterricht [Development and facilitation of motivation in education]. *Psychologie und Erziehung im Unterricht*, 45, 185-201.
- Krapp, A. (2002). An educational-psychological theory of interest and its relation to self-determination theory (SDT). In E. L. Deci & R. M. Ryan (Eds.), *Handbook of self-determination research* (pp. 405-427). Rochester: University of Rochester Press.
- Lepper, M. R., Henderlong, J., & Iyengar, S. S. (2002). *Intrinsic and extrinsic motivational orientations in the classroom: Age differences and academic correlates*. Retrieved August 11, 2005, from http://www.columbia.edu/~ss957/Lepper_Corpus_Iyengar.pdf
- Lepper, M. R., Henderlong, J., & Iyengar, S. S. (2005). Intrinsic and extrinsic motivational orientations in the classroom: Age differences and academic correlates. *Journal of Educational Psychology*, 97, 184-196.
- Levesque, C., Zuehlke, A. N., Stanek, L. R., & Ryan, R. M. (2004). Autonomy and competence in German and American university students: A comparative study based on the self-determination-theory. *Journal of Educational Psychology*, 96, 68-84.
- Lewalter, D. (2002). *Emotionales Erleben und Lernmotivation. Theoretische und empirische Analyse des Zusammenhangs von Emotionen und Motivation in pädagogischen Kontexten: Unveröffentlichte Habilitationsschrift* [Emotional experience and motivation for learning: Theoretical and empirical analysis of relationship between emotions and motivation in pedagogical context. Unpublished dissertation]. München: Fakultät für Pädagogik.
- Lewalter, D., Wild, K.-P., & Krapp, A. (2001). Interessenentwicklung in der beruflichen Ausbildung [Development of interest in professional education]. In K. Beck & V.

- Krumm (Eds.), *Lehren und Lernen in der beruflichen Erstausbildung. Grundlagen einer modernen kaufmännischen Berufsqualifizierung* (pp. 11-36). Opladen: Leske & Budrich.
- McInerney, D. M., & Etten, v., S. (Eds.). (2001). *Research on sociocultural influences on motivation and learning* (Vol. 1). Greenwich: Age Publishing.
- Miller, J. G. (1997). Cultural conceptions of duty: Implications for motivation and morality. In D. Munro, F. J. Schumaker & A. C. Carr (Eds.), *Motivation and culture* (pp. 178-192). Boston: Routledge Kegan Paul.
- Müller, F. H., & Louw, J. (2003). *Conditions of learning motivation and study interest*. Paper presented at the European Conference of Educational Research, Hamburg, Germany.
- Müller, F. H., & Louw, J. (2004). Learning environment, motivation and interest: perspectives on self-determination theory. *South African Journal of Psychology, 34*, 169-190.
- Müller, F. H., & Palekčić, M. (2005). Bedingungen und Auswirkungen selbstbestimmt motivierten Lernens bei kroatischen Hochschulstudenten [Conditions and effects of self-determined learning motivation in Croatian students]. *Empirische Pädagogik, 19*, 134-165.
- Noels, K. A. (2001). Learning Spanish as a second language: Learners orientations and perceptions of their teachers communication style. *Language Learning, 51*, 107- 144.
- Otis, F., Grouzet, M. E., & Pelletier, L. G. (2005). Latent motivational change in an academic setting: A 3-year longitudinal study. *Journal of Educational Psychology, 97*, 170-183.
- Palekčić, M., & Müller, F. H. (2004). Uvjeti i efekti interesa i motiva za izbor studija kod hrvatskih i njemačkih studenata [Conditions and effects of interest and motives for choice of study in Croatian and German students]. *Pedagogijska istraživanja, 1*, 160-193.
- Palekčić, M., Radeka, I., Petani, S., & Müller, F. H. (2004). Interes za studij. Empirijsko istraživanje uvjeta i učinaka interesa za sveučilišni studij [Study interest: Empirical research of conditions and effects of interest for study]. *Napredak, 145*, 389-404.
- Prenzel, M. (1996). Bedingungen für selbstbestimmt motiviertes und interessiertes Lernen im Studium [Prerequisites for intrinsic motivation and motivated learning in university]. In J. Lompscher & H. Mandl (Eds.), *Lehr- und Lernprobleme im Studium* (pp. 11-22). Bern: Huber.
- Prenzel, M. (1997). Sechs Möglichkeiten, Lernende zu demotivieren [Six ways to demotivate students]. In H. Gruber & A. Renkl (Eds.), *Wege des Könnens* (pp. 32-44). Bern/Göttingen: Huber.
- Prenzel, M., Eitel, F., Holzbach, R., Schoenheinz, R. J., & Schweiberer, L. (1993). Lernmotivation im studentischen Unterricht in Chirurgie [Learning motivation in training of surgery students]. *Zeitschrift für Pädagogische Psychologie, 7*, 125-137.
- Prenzel, M., Kramer, K., & Drechsel, B. (2001). Selbstbestimmt motiviertes und interessiertes Lernen in der kaufmännischen Erstausbildung: Ergebnisse des Gesamtprojektes [Intrinsic motivation and motivated learning in primary mercantile education: Results of the complete project]. In K. Beck & V. Krumm (Eds.), *Lehren und Lernen in der beruflichen Erstausbildung. Konzepte für eine moderne kaufmännische Berufsqualifizierung* (pp. 37-61). Opladen: Leske + Budrich.
- Reeve, J. (2002). Self-determination theory applied to educational settings. In E. L. Deci & R. M. Ryan (Eds.), *Handbook of self-determination research* (pp. 184-203). Rochester: University of Rochester Press.
- Ryan, R. M., Connell, J. P., & Grolnick, W. S. (1992). When achievement is not intrinsically motivated: A theory of internalization and self-regulation in school. In A. K. Boggiano & T. S. Pittman (Eds.), *Achievement and motivation: A social development perspective* (pp. 176-188). New York: Cambridge University Press.
- Ryan, R. M., & Deci, E. L. (2000). Self determination theory and the facilitation of intrinsic motivation, social development, and well-being. *American Psychologist, 55*, 68-78.
- Todt, E. (1990). Entwicklung des Interesses [Development of interests]. In H. Hetzer (Ed.), *Angewandte Entwicklungspsychologie des Kindes- und Jugendalters* (pp. 213-264). Heidelberg: Quelle & Meyer.
- Vallerand, R. J. (1997). Toward a hierarchical model of intrinsic and extrinsic motivation. In M. P. Zanna (Ed.), *Advances in experimental social psychology* (Vol. 29, pp. 271-360). San Diego: Academic Press.
- Vallerand, R. J., & Bissonnette, R. (1992). Intrinsic, extrinsic, and amotivational styles as predictors of behavior: A prospective study. *Journal of Personality, 60*, 599-620.
- Vallerand, R. J., Pelletier, L. G., Blais, M. R., Briere, N. M., Senecal, C., & Vallieres, E. F. (1992). The Academic Motivation scale. A measurement of intrinsic, extrinsic, and amotivation in education. *Educational and Psychological Measurement, 52*, 1003-1017.
- Wigfield, A., & Harold, R. D. (1997). Change in children's competence beliefs and subjective task values across the elementary school years: a 3- year study. *Journal of Educational Psychology, 89*, 451-469.
- Wild, E., & Hofer, M. (2000). Elterliche Erziehung und Veränderung motivationaler Orientierungen in der gymnasialen Oberstufe und der Berufsschule [Parental upbringing and shift in orientation of motivation in

- gymnasium and vo-tech school]. In U. Schiefele & K.-P. Wild (Eds.), *Interesse und Lernmotivation* (pp. 53-72). Münster: Waxmann.
- Wild, K.-P., & Krapp, A. (1996). Die Qualität subjektiven Erlebens in schulischen und betrieblichen Lernumwelten: Eine Untersuchung mit der Erlebens-Stichproben-Methode [The quality of subjective experience in school and real environment: analysing the experience in random samples]. *Unterrichtswissenschaft*, *16*, 195-216.
- Williams, G. C., & Deci, E. L. (1998). The importance of supporting autonomy in medical education. *Annals of Internal Medicine*, *129*, 303-308.
- Wong, E. H., Wiest, D. J., & Cusick, L. B. (2002). Perceptions of autonomy support, parent attachment, competence and self-worth as predictors of motivational orientation and academic achievement: An examination of sixth- and ninth-grade regular education students. *Adolescence*, *37*, 255-266.

