

Igor Štambuk
 Center for Defense and Strategic Studies
 Croatian Defense Academy “Dr. Franjo Tuđman”,
 Zagreb, Croatia, istambuk.edu@gmail.com

Precision Automated Measuring System for Accurate Comparison of Resistance Standards and Shunts

Summary

In this paper we will present a development of Measurement system for accurate comparison of low resistance standards and AC shunts ranging from 0.1 mΩ to 10 Ω as well as system testing and use. The system consists of a specially built current source, range selector, current reversal module and low cost analog to digital converter. The entire measurement procedure is automated and controlled by LabVIEW program. Subsequent testing has shown that the realized precision resistance measurement system has achieved precision comparable to more expensive commercial devices. The system or system elements can be used both in smart grid applications and in military laboratories for testing new technologies.

Key words: digital multimeters, measurement method, resistant standard, virtual instrumentation

Introduction

Precise impedance measurement is a key factor in many areas of science, and so far different measurement systems have been proposed: combination of commercial equipment and specific electronic circuits [1,2] and combinations of scientific commercial instruments [3,4,5] or specific systems [6,7]. However, the main difficulty in measuring mostly impedance comes when high precision is required. In this case, the width of the range is always problematic i.e., it is difficult to design a device that can meet different purposes in a wide range of resistances. There are works that have provided quality solutions for areas of 100 kΩ to 100 MΩ [8,9] and 10 kΩ to 1 TΩ [10]. For areas ranging from 0.1 mΩ to 10 Ω [11], Measurement System for accurate comparison of low resistance standards was recently developed. System is carefully designed and all electronic components used in the measuring circuit have been carefully evaluated in various situations, especially when the instruments must work properly for different metering, temperature ranges and humidity.

Labview Application for Controlling the Measurement Process

The program for controlling the measurement of small resistance of the IGMMMO is made on the LabVIEW 10.0 software platform. LabVIEW (Laboratory Virtual Instrument Engineering Workbench) is one of the most well-known development software applications from National Instruments Corporation. [12]

The IGMMMO program that communicates with the IGUS controller was implemented with the VI module »Out Port.vi« via the parallel PC interface. In normal use, the parallel port (parallel port) is most commonly used for writing to a printer or some other device connected to a computer. It sends data in a format of 8-bit or one byte in parallel at a specific time.

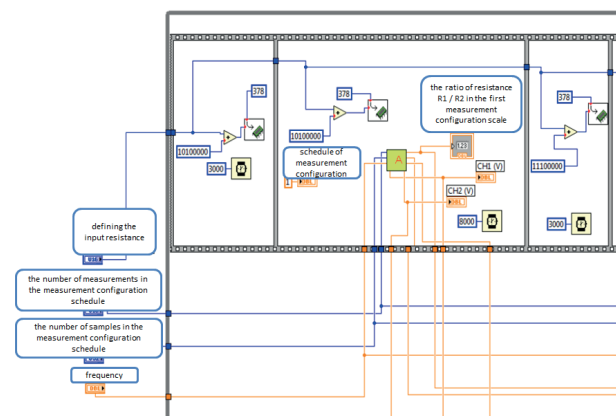

Figure 1. Labview programming time sequences

Current level for the measuring circuit

The current circuit power can be controlled automatically via the IGUS controller. With the IGMMMO measurement program, we can turn on and off the current to the resistances in the IGUS Module Control Module circuit by entering the corresponding four-digit combination into the main program. For example, for the inclusion of current to resistance of 1.5 Ω, the combination 1110 is written in a data combination that is addressed to the Module for Measurement Areas via the "Out port module. [12]

Measurement System Igmmmo

The IGMMMO method [11,13] is a specialized measurement method for measuring low resistance ratios. The method is fully automated and the resistance range that can be measured with a standard deviation of less than $1 \cdot 10^{-5}$ is from 1 mΩ to 10 Ω of rated resistance.

In order to measure the correctness, it is important to carry out the documented procedure. This procedure was followed by a series of successive measurements and tests with a new measurement system for the measurement of low resistance IGMMMO.

Figure 2. shows the basic structure of the IGMMMO measurement system.

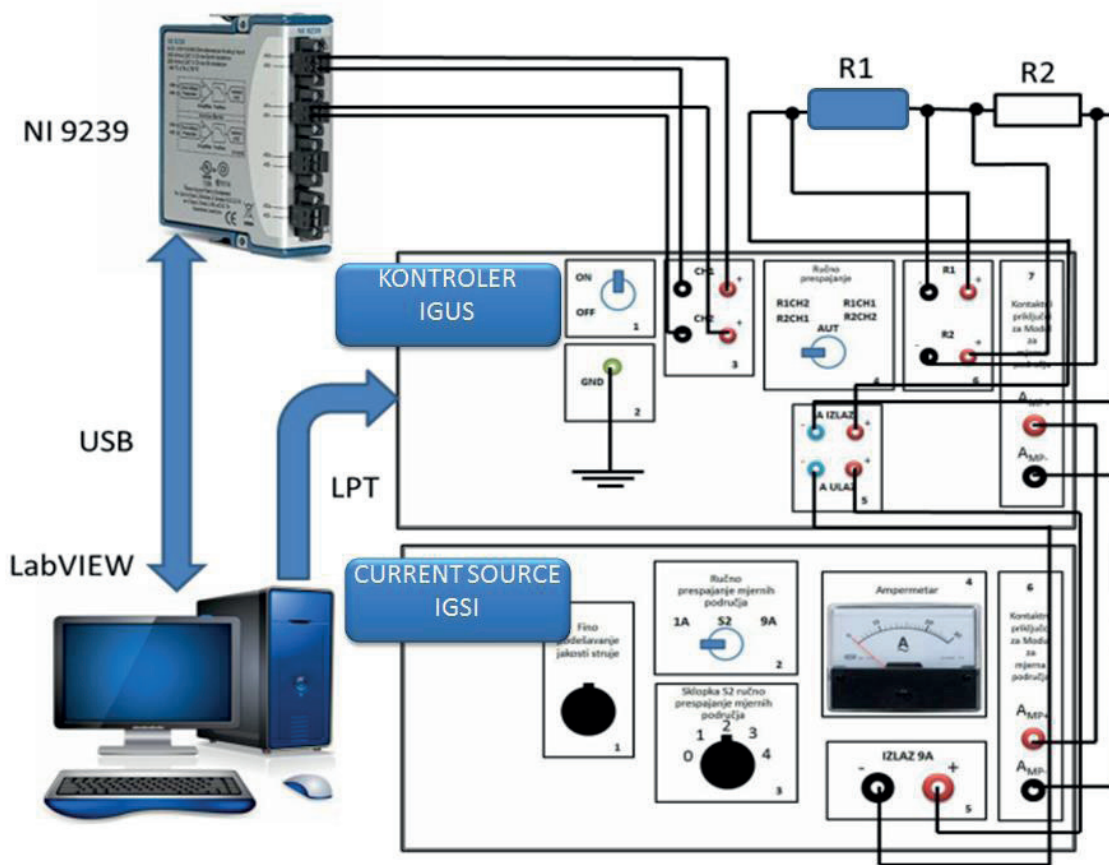

Figure 2. Measuring system IGMMMO

The system is designed to measure low resistance ratio, including the measurement resistance R1 and the known reference resistance R2. Most commonly, a known resistor is the resistance standard. The resistance of an unknown four-terminal resistor R1 is determined by measurement with the digital 24-bit A/D DAQ. It is desirable to have a standard resistor as a reference standard with four terminals, approximately the same nominal value as the resistor to be measured. The resistors are usually immersed in oil bath [14], in which the oil is stirred at a working temperature of 23 °C, monitored by mercury glass thermometer. If we calibrate resistors that are not immersed in an oil bath to maintain the same temperature level it is desirable that the temperature in the laboratory does not vary and is maintained at 23°C. The connections of each resistor (R+, R-) are connected, via the DAQ Module for changing position of DAQ measuring channels. The measurement current is derived from a personally constructed IGSI power source and is automatically regulated through the measuring range modules. It has been determined that the measurement current is large enough for the accurate voltage drops reading at low resistances of 1 mΩ and on the other hand, it will be small enough to not cause self-heating of

the resistor. The current source of IGSI is capable of producing electricity up to 9 A.

The measurement system is coupled according to Figure 2. If we measure the temperature of the resistors and in the measuring environment then we will add another DAQ measuring device with the adaptive circuit [11] and set NTC thermistor sensors to the corresponding DAQ channel. On measuring cables, i.e. cables leading to the DAQ measuring device (in our case NI 9239) it is desirable to shield and twist cable cables in order to minimize electromagnetic interference as well as external noise of the 50 Hz network.

Igus Kontroler

the most important part of the IGMMMO measuring system [12,] is the device for automated measurement control and is called the IGUS (IG controller). The device has three main purposes. Its first purpose is to regulate the power of the current through the measuring module, the second is to change the direction of the current in the measuring circuit, and the third is to change channel position of the DAQ measuring device.

The IGUS controller consists of the following modules that are separated by functional areas:

- Power Supply Module
- Measuring range module
- Module for changing direction of current
- Module for changing position of DAQ measuring channels

All these modules are built into a specially designed casing with fan cooling system and specially designed connectors for connecting with other elements of the IGMMMO measuring system.

Module for changing direction of current Module for changing position of DAQ measuring channels

Module for changing the direction of current [12,15] has the function of changing direction of current passing through measuring and reference resistor. The module is shown in Figure 3.

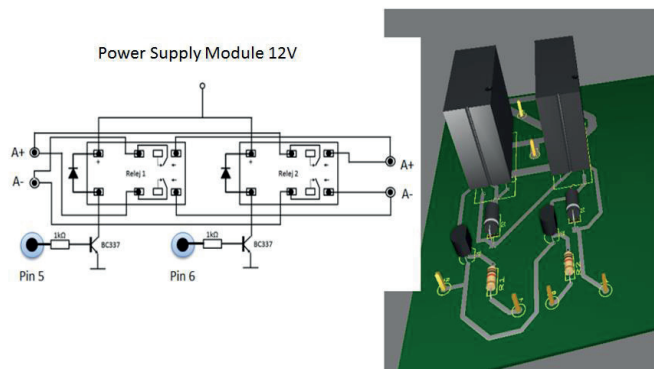

Figure 3. Current direction change module in 3D projection.

The IGUS controller is designed to affect the measurement accuracy as little as possible. The picture also shows 3D projection created using the National Instruments Ultiboard software. The IGMMMO current-changing module can be controlled via the LPT port with IGMMMO LabVIEW program. The two pins (4 and 5) control the duration of the positive and negative half-wave current as well as the duration of the non-current period.

Table I. Combinations of bits used to control the current commutation module

combination of pins		current direction
pin 4	pin 5	
0	1	positive current direction
1	0	negative current direction

Measuring the Temperature Oscillations of the Measuring Range Modul

In order to determine the temperature characteristics of the IGUS Control Unit in the measurement process in this subdivision, the results of the measurement of temperature oscillations of individual components, which are essential for proper operation of the control device, are given. Measurements were made [12] with an infrared red FLIR i7 thermo camera [16], for different loads of the measuring circuit i.e. for different current values. The results of the temperature oscillation measurement are shown for the IGUS Measuring range Module because it is subjected to the highest heating since it flows through the current I0 which is approximately the same as the measurement current, while the other modules have no significant oscillation temperature. The highest heating in the module is expected to take place on module energy resistors.

If the control bit combination (1101) is sent to the Measuring range Module, pins 1, 3 and 4 will cause a logic unit 1 to the base of the T1, T3 and T4 transistors, i.e. the voltage at which transistors will be activated and they activate the relays 1, 3 and 4. The heating of the Measuring range module in the case of a combination (1101), i.e. if the relays 1, 3 and 4 are switched on and the measuring circuit flows is 1 A, is recorded with the FLIR i7 thermo camera and the recording results are shown in Figure 4.

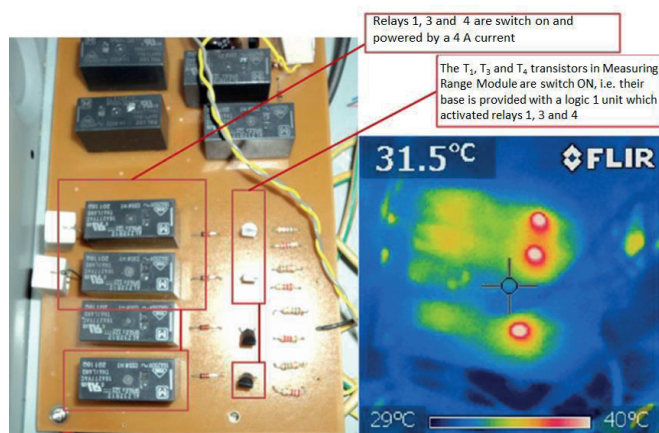

Figure 4: Thermo picture of warming up the Measuring Range Module with control panel combination (1101)

Measurement and Results Conclusion

One of the key experiments is to determine the accuracy of low-resistance measurements [12, 15, 17, 18, 19, 20, 21, and 22]. For this purpose, the IGMMMO measured the voltage drop of current shunts with nominal values of 1 mΩ and 2 mΩ. After the measurements [21], the following results were obtained - the arithmetic mean of the ratio of voltage drops on resistors was $r = 0.4376$, experimental standard deviation was $s(r) = 7.69 \cdot 10^{-6}$, and the standard deviation of the arithmetic mean of the ratio of resistance was $u(r) = 7.69 \cdot 10^{-7}$. Measurements at stable temperature conditions generally have lower standard deviations. In conclusion, we see that differences in results (standard deviation), when these two measurements are compared, are small, about $0.5 \mu\Omega/\Omega$. The temperature oscillations of the first measurement were within the range of 30.0°C to 30.2°C , while in the other experiment it was $23^\circ\text{C} \pm 0.1^\circ\text{C}$. The similarity between the results can be explained by the parallel rise in temperature of both measuring resistors, which have been heated proportionally, so their ratio did not oscillate as well. Table II summarizes the several methods available.

Table II. Comparison of tested methods

measured resistor	DV method (method with digital voltmeters)	DAQ method IGMMMO (a method with a DAQ measuring device)	DAQ method IGMMMO with current source IGSI
up to 1 mΩ	it is not good because of small voltage drops on measuring resistances	does not fully satisfies due to small voltage drops on measured resistors	satisfies because of the possibility of generating higher current through the measuring circuit and thus a higher voltage drop on measured resistors
1 mΩ - 1 Ω	the results are weaker than the DAQ method results	good (the results are better than the DV method) but it does not fully satisfies due to small voltage drops on measured resistors	very good (the results are better than the DV method)
1 Ω - 1 kΩ	very good	good (results are similar to those obtained with the DV method) more measurement ranges are used	very good (the results are similar to the DV method)

Based on the measurements shown in doctoral thesis[12], the measurement methods presented can be characterized by the nominal values of the resistors we measure. Comparison of measurement methods with digital voltmeters (DV method) of empirical methods with DAQ measuring devices (DAQ method) with and without connected current IGSI current strength up to 9 A, was conducted. From this comparison, it is visible that the IGMMMO DAQ method with the IGSI current source has very good results for almost all the ranges of the measured resistance shown in Table 2, while for a resistance range of 1 mΩ - 1 Ω, the results are even better than the DV method with digital voltmeters, enabling wider application of DAQ measuring devices as a replacement for expensive high-accuracy voltmeters.

Conclusion

The measurements were periodically repeated, usually one time per month, to estimate the time stability of the measuring system when measuring the resistance standards. During the test period, and according to the obtained results, it can be seen that there is very little deviation in measurement results at all-time intervals, although the results show time-nonlinear behavior, which suggests that the IGMMMO measurement system has a satisfactory time stability.

Based on the obtained results, the results of the standard deviation, and the comparison of the obtained results with the previously determined resistance values and resistance standards, we see that the IGMMMO system fully satisfies its primary task of measuring ratio of low voltage resistances of rated values in the range of 1 mΩ - 1 Ω, with a standard deviation of lower than $8 \mu\Omega / \Omega$.

References

- Putta, S.; Vaidyanathan, V.; Chung, J.; Development and testing of a nodal resistance measurement (NRM) system for composite structures, *Measurement* 2008, 41, 763–773. [Google Scholar] [CrossRef]
- Silvia Casans, Alfredo Rosado-Muñoz and Taras lakymchuk; 'Novel Resistance Measurement Method: Analysis of Accuracy and Thermal Dependence with Applications in Fiber Materials'
- Kandala, C.; Nelson, S.; RF Impedance method for estimating moisture content in small samples of In-Shell peanuts. *IEEE Trans. Instrum. Meas.* 2007, 56, 938–943. [Google Scholar] [CrossRef]
- Isaksson, T.; Thelandersson, S. Experimental investigation on the effect of detail design on wood moisture content in outdoor above ground applications. *Build. Environ.* 2013, 59, 239–249. [Google Scholar] [CrossRef]
- Brischke, C.; Lampen, S.C. Resistance based moisture content measurements on native, modified and preservative treated wood. *Eur. J. Wood Wood Prod.* 2014, 72, 289–292. [Google Scholar] [CrossRef]
- Fan, D.; Xue, J. The design of intelligent automatic test system for wood moisture content test. In *Proceedings of the 2010 International Conference on Computer Design and Applications (ICCCA)*, Qinhuaangdao, China, 25–27 June 2010; Volume 3, pp. 314–316.
- Zhang, J.; Wang, P. Online monitoring and detecting of wood drying kilns' parameters based on embedded system. In *Proceedings of the 2013 25th Chinese Control and Decision Conference (CCDC)*, Guiyang, China, 25–27 May 2013; pp. 4189–4193.
- Tadros, N.N.; Ali, R.S.M. Automated accurate high value resistances measurement in the range from 100 k Ω to 100 M Ω at NIS. *Measurement* 2012, 45, 988–992. [Google Scholar] [CrossRef]
- Tadros, N.N.; Ali, R.S.M. Improved system for the automatic calibration of standard resistors in the meg-ohm range. *Measurement* 2013, 46, 2077–2081. [Google Scholar] [CrossRef]
- Galliana, F.; Capra, P.P.; Gasparotto, E. Metrological management of the high DC resistance scale at INRIM. *Measurement* 2009, 42, 314–321. [Google Scholar] [CrossRef]
- Štambuk, I.; Malaric R.; Measurement system for precise comparison of low ohmic resistance standards. *Measurement* 2013, 46, 161–167
- Štambuk, I.; Mjermi sustav za preciznu usporedbu etalona otpora malih nazivnih vrijednosti, PhD, FER, Zagreb, 2014.
- I. Štambuk, R. Malaric', Development of 9 A current source for precise resistance measurement method, *Rev. Sci. Instrum.* 83 (2012).
- R. Malaric', Maintenance of the Group Resistance Standards of the Primary Electromagnetic Laboratory, PhD, FER, Zagreb, 2001.
- Štambuk I.; Automated low resistance measurement system suitable for DC characterization of AC shunts // *Proceedings of First International Colloquium on Smart Grid Metrology 2018 (SMAGRIMET 2018)* / Ivšić, Branimir; Jurčević, Marko (ur.).
- Technical Specifications, FLIR i7 Thermal Imaging Camera 120 120 Resolution <<http://www.amazon.com/FLIR-i7-Thermal-Imaging-Resolution/dp/B003V4BE20>> (02.lipnja.14).
- Braudaway, D., »Precision Resistors: A review of the techniques of measurement, Advantages, Disadvantages and Practical Approach«, *IEEE Trans. Instrum. Meas.* Vol.48, No. 5, pp. 884–888', October 1999.
- Guidline Instruments Limited, *Advances in High Current and Resistance Measurements*, 2011 <<http://www.guidline.com/Data-sheet/Guidline6625ADatasheet.pdf>>.
- H. Hegeduš, R. Malaric', P. Mostarac, I. Štambuk, Measurement of resistance ratios with digital voltmeter and DAQ Card – A comparison, *CPEM Digest/Yang Sup Song* (ur.). – Daejeon: IEEE, 2010, pp. 645–646.
- Gert Rietveld, Jan van der Beek, and Ernest Houtzager, DC characterization of AC current shunts for wideband power applications, http://projects.npl.co.uk/power_energy/docs/5%20DC%20characterization%20of%20AC%20current%20shunts.pdf
- David Deaver, Neil Faulkner, Characterization of the Power Coefficient of AC and DC Current Shunts
- G. Rietveld, Ernest Houtzager, DC characterisation of ac current shunts for wideband power applications
- EA-4/02, Evaluation of the Uncertainty of Measurement in Calibration, September 2013.
- Hewlett-Packard, »Hewlett-Packard 3458A Multimeter Calibration Manual«.
- Kessler-electronic, »Relais F4052-12«, dostupno na: [http://www.kessler-electronic.de/Elektromechanik/Relais/Finder/Serie_4052/F4052-12_i1362_31582_0.htm](http://www.kessler-electronic.de/Elektromechanik/Relais/Elektromechanische_Relais/Finder/Serie_4052/F4052-12_i1362_31582_0.htm), (10. siječnja 2014.)
- National instruments, »User guide and specifications: NI USB-9229/9239«, dostupno na: www.ni.com/Pdf/Manuals/372409a.pdf, (17. kolovoza 2010.)