

DESIGN OPTIMIZATION OF A DISC BRAKE BASED ON A MULTI-OBJECTIVE OPTIMIZATION ALGORITHM AND ANALYTIC HIERARCHY PROCESS METHOD

Summary

Multiple optimization objectives and the Pareto set often arise from engineering structural optimization. Normalization methods (such as the weighting method) have the disadvantage that the weighted value is not set by the decision maker but the designer and is greatly influenced by the opinion of the designer. On this basis, in this paper a non-dominated sorting genetic algorithm - analytic hierarchy process (NSGA-AHP) method is proposed for decision making and analysis of the Pareto solution set of the multiple-objective optimization in a structural optimal model. In addition, illustrated by the example of a disc brake, a multiple-objective optimization model for a disc brake has been here developed. Besides, the NSGA-AHP method is adopted for the analysis optimization. The research results show that the NSGA-AHP method can be utilized to select the Pareto solution set in an effective way and that this method is effective in solving a multiple-objective problem in the structural optimization design.

Key words: disc brake; multiple-objective optimization; Pareto set; analytic hierarchy process; NSGA-II

1. Introduction

The multiple-objective optimization has attracted increasing attention in recent years. Multiple optimization objectives and the Pareto set often arise from engineering structural optimization. In most existing algorithms, multiple objective functions are normalized so that multiple objectives are turned into a single objective. The normalization-based methods (such as the weighting method) have the disadvantage that the weighted value is not set by the decision maker but by the designer and is greatly influenced by the opinion of the designer. As opposed to the single objective algorithm, the multiple-objective optimization NSGA-II adopts the non-normalization method and does not convert multiple objectives into a single objective. This non-normalization method can achieve more solution sets for the leading edge and the Pareto set. But the solutions of the Pareto set are uncertain and non-unique.

The Pareto solution set is always of utmost important in the multiple-objective optimization. Aiming at the Pareto solution set of multiple-objective optimization, the weight analysis methods are mainly adopted in structural optimization such as those presented in [1-10]. The idea that the weight is related to the slope of the Pareto curve in the objective space in a way that an even spread of Pareto points actually corresponds to often very uneven distributions of weights has been proposed [1]. The paper [2] presented a method for predicting a relative objective weighting scheme necessary to cause members of a Pareto set to become optimal. The papers [3] proposed a max-min algorithm and a weighted sum method to achieve balance for multiple objectives aiming at multiple-objective optimization. The paper [5] conducted multiple-objective optimization by restraining the minimum weight of a ship with the finite element analysis technology. A multiple-objective optimization problem in uncertain environment and a multiple-objective optimization method aiming at problems of optimal structural design with incomplete data concerning applied external loads have been proposed [7,8], but the solutions of the Pareto set are still not confirmed .

Due to a series of advantages such as their simple and compact structure, favorable heat stability and water stability and a small possibility of formation of hot tearing and hotspots at high temperatures, disc brakes have been widely applied in engineering machinery and automobiles. The optimization of a disc brake of an automobile is actually a multiple-objective optimization problem [11,12]. The papers [13,14] proposed a reliable optimization method for the disc brake. A multidisciplinary design optimization (MDO) procedure to obtain optimal design parameters of a brake disc was proposed in [15]. Multi-objective optimization of a disc brake system of a heavy truck by using the evolutionary multi-objective optimization and radial basis function networks (RBFNs) was presented for three conflicting objectives [12]. The studies [16-18] conducted related research on the disc brake by utilizing the finite element method for the structural optimization. An efficient approach to simulate thermal stresses due to temperature variations in disc brakes was also presented [19]. A genetic algorithm was applied for the parameterized optimization procedure of a brake disc [18-20]. In addition, the Monte-Carlo method combined with genetic algorithm was used to translate multiple objectives into a single objective [20]. The above studies optimize the disc brake mainly with two optimization methods: the first is the optimization of the disc brake by utilizing the finite element-based method; the second method is the multiple-objective optimization-based optimization strategy, which converts multiple objectives into a single objective, with no explanation of the Pareto principle.

On this basis, in this paper a non-dominated sorting genetic algorithms-analytic hierarchy process (NSGA-AHP) method is proposed for decision making and analysis of the Pareto set of the multiple-objective optimization in the structural optimization model. By taking a disc brake as an example, a multiple-objective optimization model of a disc brake is developed. Optimization objectives in the design of a disc brake are minimum braking time, minimum thickness of the brake disc and minimum temperature rise in the brake disc. The Pareto solution set of the disc brake is acquired, and the hierarchical analysis algorithm is adopted to conduct decision making and selection of the Pareto solution.

The structure of the paper is as follows: The first part introduces a multiple-objective optimization algorithm. The second part presents a multiple-objective optimal model of the disc brake structure. The third part introduces the application of the hierarchical analysis to the multiple-objective optimization of the disc brake. The fourth part includes tests and analysis.

2. Multiple-objective optimization

The mathematical model of the multiple-objective optimization design is generally expressed as follows:

$$\begin{cases} \text{Min: } \mathbf{F}(\mathbf{x}) = \{f_1(\mathbf{x}), f_2(\mathbf{x}), \dots, f_m(\mathbf{x})\} \\ \text{s.t. } g_j(\mathbf{x}) \leq 0 \quad j = 1, \dots, q \\ h_k(\mathbf{x}) = 0 \quad k = 1, \dots, p \end{cases} \quad (1)$$

in which, $\mathbf{x} = [x_1, x_2, \dots, x_n]^T \in R^n$ is a n-dimensional design variable; $\mathbf{F}(\mathbf{x})$ is the objective function vector of the optimization model; $f_i(\mathbf{x})$ is the i^{th} sub-objective function; m is the number of the sub-objective functions; $g_j(\mathbf{x})$ is the j^{th} inequality constraint; q is the number of the inequality constraints; $h_k(\mathbf{x})$ is the k^{th} equality constraint; p is the number of the equality constraints.

It is difficult to achieve optimization for all the objectives set for the above problem of objective function optimization. Especially when there are conflicts among various objectives; i.e., when there are conflicts among the solutions to various problems, it is applicable to expect overlapping of minimal points; i.e., it is impossible to achieve the optimal solutions to all problems at the same time. Therefore, it is necessary to coordinate among optimal solutions to various problems, to make appropriate “compromises”, so as to acquire the optimal global scheme.

3. Multiple-objective optimal model of a disc brake

In order to analyze the problem in a convenient way, the following assumptions have been made: (1) A solid disc is adopted for the disc brake; (2) The brake caliper floats, so as to eliminate the bending stress on the disc; (3) The brake block is a circle, with a dimension not necessarily equal to the diameter of the loaded oil cylinder; (4) The absorbed friction heat is distributed uniformly on the whole brake.

3.1 Development of the objective function model

It is critical to improve the working efficiency of the brake and shorten the braking time so as to ensure the driving safety of an automobile. Therefore, the minimum braking time is taken as the objective of the optimal design of the brake. In addition, the minimum thickness and the minimum temperature rise in the disc brake can be taken as other two objectives to be achieved by the optimal design. The structural relationship between the caliper and the brake disc is shown in Fig. 1. The circular friction surface of the friction lining is dispersed to the concentric arc circle with the disc, as shown in Fig. 2.

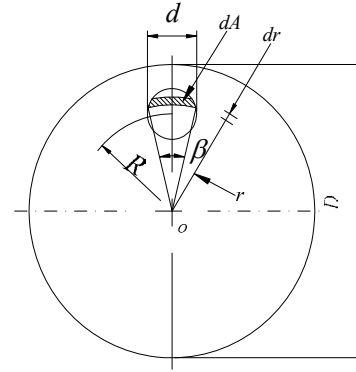
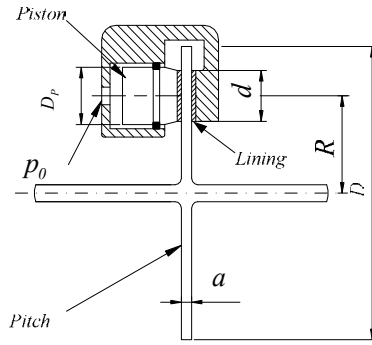

Fig. 1 Structural drawing of the disc brake caliper

Fig. 2 Calculation chart of the brake

R - distance between the center of the friction lining pad and the brake disc shaft; d - diameter of the friction lining; D - diameter of the brake disc; D_p - diameter of the piston; a - thickness of the brake disc; p_0 - oil pressure in the brake cylinder.

3.1.1 Braking time

Considering that the uneven wear process will make the Pv value (unit pressure \times trackslip speed) tend to become uniform on the whole friction surface, the following equation can be obtained [21]:

$$pr = C \quad (2)$$

The acting force of the whole lining to the disc F_0 is:

$$F_0 = \int p dA = \int \frac{C}{r} dA = \int_{R-d/2}^{R+d/2} \frac{C}{r} l dr \quad (3)$$

in which: l is the arc length of the unit; according to the geometric relationship presented in Figure 2:

$$l = r \cdot \beta = 2r \cdot \cos^{-1} \left(\frac{R^2 + r^2 - (d/2)^2}{2Rr} \right) \quad (4)$$

The friction torque during braking T_f is:

$$T_f = 2 \int_{R-d/2}^{R+d/2} \mu p r dr = 2 \int_{R-d/2}^{R+d/2} \mu \frac{F}{I_1 r} r l dr = 2 \mu F \int_{R-d/2}^{R+d/2} \frac{l}{I_1} dr = 2 \mu F I_2 \quad (5)$$

in which, μ is the friction coefficient between the brake disc and the lining; F is the piston thrust of the high pressure oil cylinder; $I_1 = \int_{R-d/2}^{R+d/2} \frac{l}{r} dr$, $I_2 = \int_{R-d/2}^{R+d/2} \frac{l}{I_1} dr$

The power consumed by the friction torque in each full rotation of the brake disc during braking is:

$$H = T_f \cdot 2\pi = 4\pi F \mu I_2 \quad (6)$$

If n_0 is the revolving speed of the brake disc or the automobile wheel before braking (r/min) and t is the time from the start of the braking to the full stop of the vehicle, i.e., the braking time (min), the total lap speed of the brake disc or the automobile wheel during the braking process is:

$$n_s = \frac{n_0}{2} t \quad (7)$$

Therefore, the total power consumed by the friction torque between the lining and the brake disc during the braking process is:

$$E = n_s \cdot H = 2\pi F \mu n_0 t I_2 \quad (8)$$

Friction consumes the kinetic energy of automobiles; therefore:

$$E = \frac{1}{n} \frac{W_a \cdot v^2}{2g} \quad (9)$$

Substitute it into formulae (8, 9) to obtain the braking time (the total power consumed between the lining and the brake disc during the braking process is equal to the kinetic energy of the vehicle).

$$t = \frac{W_a \cdot v^2}{4\pi F \mu I_2 \cdot n_0 m g} \quad (10)$$

where W_a is the total weight of the vehicle; v is the initial velocity of the vehicle during braking; n_0 is the number of automobile wheels or brakes; g is the gravitational acceleration.

Whereby the piston thrust of the high pressure oil cylinder F is as follows:

$$F = \frac{\pi}{4} D_p^2 \cdot p_0 \quad (11)$$

where D_p is the diameter of the piston; p_0 is the oil pressure in the oil cylinder.

3.1.2 Temperature rise in the brake disc

The temperature rise in the disc after braking can be obtained according to the heat equivalent of work:

$$\frac{E}{J} = (t_f - t_i) c \rho \frac{\pi D^2 a}{4} \quad (12)$$

The temperature of the brake disc after braking is:

$$t_f = \frac{4E}{J\pi c \rho D^2 a} + t_i \quad (13)$$

$$\Delta t = t_f - t_i = \frac{4E}{J\pi c \rho D^2 a} \quad (14)$$

where t_f is the temperature of the brake disc after braking; t_i is the initial temperature or air temperature of the brake disc; c is the specific heat of the brake disc; ρ is the density of the brake disc; J is the mechanical equivalent of heat.

Therefore, the objective function of the disc brake is:

$$F(x) = \text{Min} \{f_1(x), f_2(x), f_3(x)\} \quad (15)$$

where, $f_1(x) = t, f_2(x) = a, f_3(x) = \Delta t = \frac{4E}{J\pi c \rho x_3^2 x_5}$.

3.2 Design variables

$X = [x_1, x_2, x_3, x_4, x_5, x_6] = [R, d, D, D_p, a, p_0]$; please refer to Figure 1 for various parameters.

3.3 Definition of constraint conditions

The following optimization restraint equation is established:

$$s.t. \quad \left\{ \begin{array}{l} x_1 + x_2/2 + D_h/2 \leq 0 \\ x_1 + \frac{1}{2}x_2 - \frac{1}{2}x_3 \leq 0 \\ -x_1 + \frac{1}{2}x_4 + t_c + \frac{1}{2}D_h \leq 0 \\ \frac{\pi x_4^2 x_6}{4I_1(x_1 - \frac{x_2}{2})} - [p_{max}] \leq 0 \\ 2FI_2 - W \cdot r\varphi \leq 0 \\ \frac{4E}{J\pi c \rho x_3^2 x_5} + T_i - [T_{max}] \leq 0 \end{array} \right. \quad (16)$$

4. Applications of the hierarchical analysis method in the multi-objective optimization of the disc brake

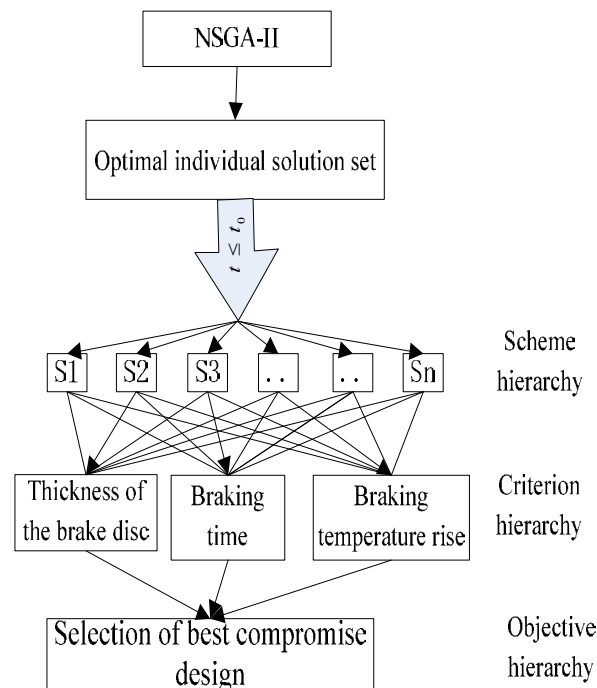

Fig. 3 Flowchart of multiple-objective optimization of a disc brake using the analytic hierarchy process method

The flowchart of the multiple-objective optimization of a disc brake using the analytic hierarchy process method is illustrated in Fig. 3.

Step one: the multiple-objective optimization model of a disc brake is developed, and the multiple-objective optimal model is solved by utilizing the NSGA-II. It mainly includes: generation of initial population, setting of computing fitness, selection, crossover and mutation parameters, and the Pareto solution set satisfying the optimization criterion is acquired.

Step two: selection of the best compromise design by utilizing the analytic hierarchy process. It mainly includes the following procedures: 1) the selection problem of the designer is expressed with a hierarchical structure model. The first hierarchy is the scheme hierarchy (with various designs), the scheme hierarchy is the Pareto set which is a result of the NSGA-II optimization and the second hierarchy is the criterion hierarchy (braking time, thickness of the brake disc and temperature rise during braking), and the third hierarchy is the objective hierarchy (the optimal scheme). 2) the weight of the elements of the same hierarchy with respect to the superior hierarchy is calculated and determined. The geometric mean w_i and weight U_i of the elements of each line of the judgment matrix are further calculated and judged. 3. The judgment matrix is constructed. 4. The total hierarchy ordering vector is calculated. 5. The optimal scheme is selected [22,23].

Firstly, the criterion for the pair-wise comparison of factors is established, as shown in Table 1. Then, the judgment matrix of the pair-wise comparison of the factors of the criterion hierarchy is established, as shown in Table 2.

Table 1 Method for judgment of the scale of the matrix element a_{ij}

Scale	Definition
1	The same importance
3	Minor importance
6	Significant importance
9	Absolute importance
Reciprocal of the above numbers	The comparison between the element j and i yields, b_{ji} if the comparison between the element i and j yields b_{ij} .

Table 2 Judgment matrix

Criterion	Braking thickness a	Braking time t	Braking temperature rise ΔT
Braking thickness a	1	$\frac{1}{9}$	$\frac{1}{6}$
Braking time t	9	1	1
Braking temperature rise ΔT	6	1	1

$$w_i = \sqrt[n]{\prod_{j=1}^n a_{ij}} \quad (17)$$

$$U_i = w_i / \sum_{i=1}^n w_i \quad (18)$$

where a_{ij} is the value of the judgment matrix of the pair-wise comparison between the i^{th} line and the j^{th} line; w_i is the sum of the geometric mean; U_i is the relative weight of various factors.

It is set that the n designs of the scheme hierarchy correspond to certain index in the criterion hierarchy; the following judgment matrix B_j can be constructed according to the pair-wise comparisons of the designs:

$$B_j = [b_{ik}^j]_{n \times n} \quad (j = 1, 2, \dots, m_0) \quad (19)$$

where m_0 is the number of objectives. The following three conditions for the adoption of values of b_{ik}^j in the formula are:

(1) Provided that G_j is a positive index, a higher index value is more beneficial to the scheme. That is to say, the priority of the designs can be determined according to the magnitude of the index values.

$$b_{ik}^j = \frac{a_{ij}}{a_{kj}} \quad (a_{kj} > 0) \quad (20)$$

(2) Provided that G_j is a negative index, a higher index value is more unfavourable to the scheme. But a higher reciprocal value of the index value is more beneficial to the scheme. Therefore, according to formula (20):

$$b_{iK}^j = \frac{1/a_{ij}}{1/a_{Kj}} = \frac{a_{Kj}}{a_{ij}} \quad (a_{ij} > 0) \quad (21)$$

(3) Provided that G_j is a central index, a smaller difference to the central value (recorded as a_{Fj}) is more beneficial to the scheme; otherwise it is more unfavorable to the scheme, which can be described with the following normalization formula. Larger index a'_{ij} is more beneficial to the scheme. Based on formula (20):

$$a'_{ij} = \frac{a_{Fj}}{a_{Fj} + |a_{ij} - a_{Fj}|} \quad (22)$$

$$b_{iK}^j = \frac{a'_{ij}}{a'_{Kj}} = \frac{a_{Fj} + |a_{Kj} - a_{Fj}|}{a_{Fj} + |a_{ij} - a_{Fj}|} \quad (a_{ij} > 0) \quad (23)$$

According to the definition of the consistency matrix, it is easy to prove the consistency of the judgment matrix B_j constructed according to the above method. As for the consistency judgment matrix B_j , the corresponding weight vector is set as $W = [W_1, W_2, \dots, W_n]^T$:

$$\begin{bmatrix} \frac{W_1}{W_1} & \frac{W_1}{W_2} & L & \frac{W_1}{W_n} \\ \frac{W_2}{W_1} & \frac{W_2}{W_2} & L & \frac{W_2}{W_n} \\ \frac{W_1}{W_1} & \frac{W_2}{W_2} & L & \frac{W_2}{W_n} \\ L & L & L & L \\ \frac{W_n}{W_1} & \frac{W_n}{W_2} & L & \frac{W_n}{W_n} \end{bmatrix} = \begin{bmatrix} b_{11}^j & b_{12}^j & L & b_{1n}^j \\ b_{21}^j & b_{22}^j & L & b_{2n}^j \\ L & L & L & L \\ b_{n1}^j & b_{n2}^j & L & b_{nn}^j \end{bmatrix} \quad (24)$$

All the elements of the above columns summed are as follows:

$$\left[\frac{\sum_{i=1}^n W_i}{W_1}, \frac{\sum_{i=1}^n W_i}{W_2}, \dots, \frac{\sum_{i=1}^n W_i}{W_n} \right] = \left[\sum_{i=1}^n b_{i1}^j, \sum_{i=1}^n b_{i2}^j, \dots, \sum_{i=1}^n b_{in}^j \right] \quad (25)$$

It is obvious that:

$$\frac{\sum_{i=1}^n W_i}{W_K} = \sum_{i=1}^n b_{iK}^j \quad (K = 1, 2, \dots, n) \quad (26)$$

The normalized weight value is:

$$\bar{W}_{Kj} = \frac{W_K}{\sum_{i=1}^n W_i} = \frac{1}{\sum_{i=1}^n b_{iK}^j} \quad (K = 1, 2, \dots, n; j = 1, 2, \dots, m) \quad (27)$$

In conclusion, the calculating procedures for solving quantitative multiple-objective decision problems can be concluded as follows [24,25]:

- (1) The index matrix is established $A = [a_{ij}]_{n \times n}$ ($a_{ij} > 0$);
- (2) The judgment matrix is constructed $B_j = [b_{iK}^j]_{n \times n}$ ($j = 1, 2, \dots, m$);
- (3) The feature vector matrix is solved $\bar{W} = [\bar{W}_1, \bar{W}_2, \dots, \bar{W}_n] = [\bar{W}_{Kj}]_{n \times n}$;
- (4) The total hierarchy ordering vector is calculated $V = [V_1, V_2, \dots, V_n]^T = \bar{W}U$ (28)
- (5) The optimal scheme is selected, if $V_{i1} \geq V_{i2} \geq \dots \geq V_{in}$

The optimal ordering is:

$$A_{i1} \geq A_{i2} \geq \dots \geq A_{in}$$

5. Test and analysis

Firstly, the optimal solution is solved in this paper by adopting the conventional weighing method first, and then the optimal Pareto solution is solved by adopting the hierarchical analysis method-based multiple-objective decision method. Then, the feasibility of the scheme is verified by making comparisons between the two designs. The parameters related to the disc brake are: steel versus cast iron: $c=0.113$ kcal/(kg°C); $\rho = 7.85$ (kg/mm³); $J=4180$ N·m/kcal

5.1 Weighting method

Taking the differences among braking time, thickness of the brake disc and braking temperature rise into consideration, the weighting factor can be introduced and integrated into the total objective function. Considering also that different people have different importance degrees with respect to the three indexes and there is no specific criterion for weight selection, three groups of different weighting factors are selected to acquire optimal values after comparison.

$$\text{Group A1: } w_A = [0.25, 0.3, 0.45] ;$$

$$\text{Group A 2: } w_B = [0.61, 0.32, 0.07] ;$$

$$\text{Group A 3: } w_C = [0.35, 0.64, 0.01] ;$$

The objective function is:

$$F(x) = \begin{cases} F_{A1}(x) = 0.25t + 0.3a + 0.45(t_f - t_i) = 0.25 \frac{W_a V^2}{4\pi F \mu_0 I_2 mg} + 0.3a + 0.45 \frac{4E}{J\pi \rho x_3^2 x_5} \\ F_{A2}(x) = 0.61t + 0.32a + 0.07(t_f - t_i) = 0.61 \frac{W_a V^2}{4\pi F \mu_0 I_2 mg} + 0.32a + 0.07 \frac{4E}{J\pi \rho x_3^2 x_5} \\ F_{A3}(x) = 0.35t + 0.64a + 0.01(t_f - t_i) = 0.35 \frac{W_a V^2}{4\pi F \mu_0 I_2 mg} + 0.64a + 0.01 \frac{4E}{J\pi \rho x_3^2 x_5} \end{cases} \quad (29)$$

Parameters of the weighting method scheme are illustrated in Table 3 after the program execution.

Table 3 Parameters of the weighting method scheme

Optimal scheme	R (mm)	d (mm)	D (mm)	D_p (mm)	p_0 (MPa)	a (mm)	t (s)	ΔT (°C)
Original parameters	105	40	256	48	2.5	12	11.41	150.57
A1	107.71	49.63	280	47.64	2.52	12.58	11.2	120.06
A2	105.82	43.07	280	47.58	1.95	12.93	14.65	116.83
A3	108.30	50.88	280	47.95	2.59	12.99	10.71	116.23

According to the objective function values of the three groups of data, A1, A2 and A3, and considering the importance of braking time and braking temperature rise, it is obvious that the results of the group A3 data are optimal. That is, when the radius of the central circle of the friction lining, R , is 108.30 mm, the diameter of the friction lining, d , is 50.88 mm, the brake disc diameter, D , is 280 mm, the piston diameter D_p is 47.95 mm; the thickness of the brake disc, a , is 12.99 mm and the oil pressure in the oil cylinder, p_0 , is 2.59 MPa, optimal objective functions are listed as follows: braking time, t , is 10.71 s; thickness of the brake disc, a , is 12.99 mm; temperature rise in the brake disc, ΔT , is 116.23°C.

5.2 Analytic hierarchy process based multiple-objective decision

The NSGA-II algorithm is utilized for optimizing the disc brake model. The parameters of NSGA-II are set as shown in Table 4. A Pareto leading edge diagram is drawn to determine the optimal discrete point set. A three-dimensional Pareto leading edge diagram is shown in Fig. 4.

Table 4 NSGA-II algorithm parameter setting

Population size	Stop algebra	Fitness function value deviation	Optimal front end individual coefficient	Maximum iterative algebra
500	200	1e-100	0.3	200

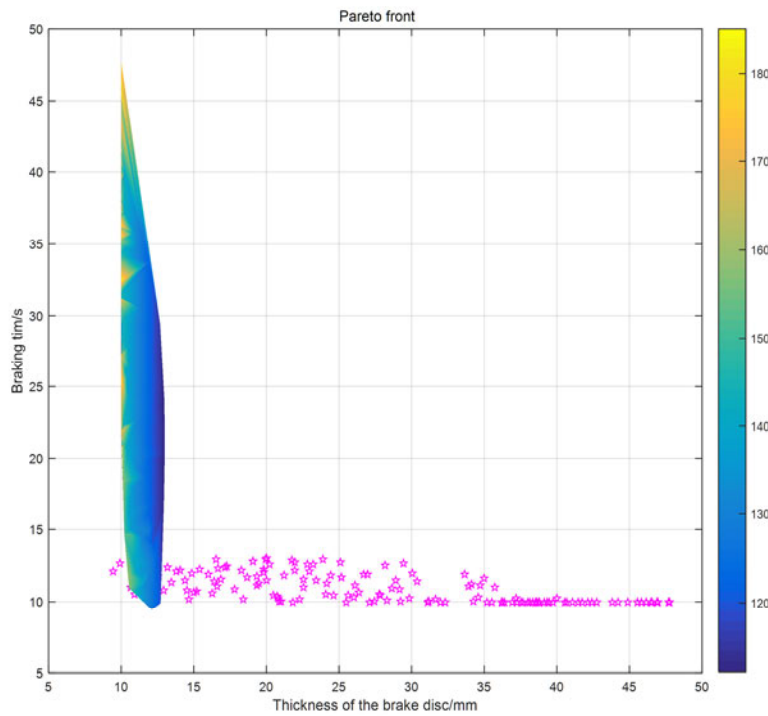

Fig. 4 Three-dimensional Pareto leading edge diagram

There are totally 150 groups of solutions meeting corresponding conditions. According to the standard GB7258-2012 for brake braking time, set $t \leq t_0$. In total, six groups of designs are acquired with $t \leq t_0$ and $t_0 = 12$ s due to the limitation of the braking time: S1, S2, S3, S4, S5 and S6. Scheme parameters are given in Table 5.

Table 5 Parameters of the designs

Optimal scheme	Design variable					Objective function		
	R (mm)	d (mm)	D (mm)	D_p (mm)	p_0 (MPa)	a (mm)	t (s)	ΔT (°C)
S1	115.23	35.93	279.51	44.02	2.87	12.35	10.76	122.77
S2	111.96	41.30	277.23	46.20	2.85	11.37	10.14	135.49
S3	113.20	39.96	279.52	46.50	2.44	11.63	11.56	130.35
S4	115.30	35.96	279.54	44.02	2.90	12.28	10.64	123.37
S5	115.16	36.71	279.51	44.09	2.69	12.20	11.43	124.75
S6	114.95	36.52	280.45	44.33	2.76	12.01	11.07	125.39

Based on formulae (17, 18), the standard weight of various indexes can be calculated as follows: $w = [0.246, 2.0801, 1.8171]^T$, $U = [0.0636, 0.4998, 0.4366]^T$.

Each objective is examined as follows:

① The thickness index G_1 is a negative index; i.e., greater thickness is more unfavorable to the scheme. Therefore, the judgment matrix is established according to formula (21), as shown in Table 6.

② The time index G_2 is a negative index; i.e., longer time is more unfavorable to the scheme. Therefore, the judgment matrix is established according to formula (21), as shown in Table 7.

③ The time index G_3 is a negative index; i.e., higher temperature rise is more unfavorable to the scheme. Therefore, the judgment matrix is established according to formula (21), as shown in Table 8.

Table 6 Pair-wise comparison of alternatives in terms of thickness

G_1	S1	S2	S3	S4	S5	S6	Local priority
S1	1	$\frac{11.37}{12.35}$	$\frac{11.63}{12.35}$	$\frac{12.28}{12.35}$	$\frac{12.20}{12.35}$	$\frac{12.01}{12.35}$	0.1614
S2	$\frac{12.35}{11.37}$	1	$\frac{11.63}{11.37}$	$\frac{12.28}{11.37}$	$\frac{12.20}{11.37}$	$\frac{11.01}{11.37}$	0.1754
S3	$\frac{12.35}{11.63}$	$\frac{11.37}{11.63}$	1	$\frac{12.28}{11.63}$	$\frac{12.20}{11.63}$	$\frac{12.01}{11.63}$	0.1714
S4	$\frac{12.35}{12.28}$	$\frac{11.37}{12.28}$	$\frac{11.63}{12.28}$	1	$\frac{12.20}{12.28}$	$\frac{12.01}{12.28}$	0.1624
S5	$\frac{12.35}{12.20}$	$\frac{11.37}{12.20}$	$\frac{11.63}{12.20}$	$\frac{12.28}{12.20}$	1	$\frac{12.01}{12.20}$	0.1634
S6	$\frac{12.35}{12.01}$	$\frac{11.37}{12.01}$	$\frac{11.63}{12.01}$	$\frac{12.28}{12.01}$	$\frac{12.20}{12.01}$	1	0.1660

Table 7 Pair-wise comparison of alternatives in terms of time

G_2	S1	S2	S3	S4	S5	S6	Local priority
S1	1	$\frac{10.14}{10.76}$	$\frac{11.56}{10.76}$	$\frac{10.64}{10.76}$	$\frac{11.43}{10.76}$	$\frac{11.07}{10.76}$	0.1690
S2	$\frac{10.76}{10.14}$	1	$\frac{11.56}{10.14}$	$\frac{10.64}{10.14}$	$\frac{11.43}{10.14}$	$\frac{11.07}{10.14}$	0.1794
S3	$\frac{10.76}{11.56}$	$\frac{10.14}{11.56}$	1	$\frac{10.64}{11.56}$	$\frac{11.43}{11.56}$	$\frac{11.07}{11.56}$	0.1573
S4	$\frac{10.76}{10.64}$	$\frac{10.14}{10.64}$	$\frac{11.56}{10.64}$	1	$\frac{11.43}{10.64}$	$\frac{11.07}{10.64}$	0.1709
S5	$\frac{10.76}{11.43}$	$\frac{10.14}{11.43}$	$\frac{11.56}{11.43}$	$\frac{10.64}{11.43}$	1	$\frac{11.07}{11.43}$	0.1591
S6	$\frac{10.76}{11.07}$	$\frac{10.14}{11.07}$	$\frac{11.56}{11.07}$	$\frac{10.64}{11.07}$	$\frac{11.43}{11.07}$	1	0.1643

Table 8 Pair-wise comparison of alternatives in terms of temperature rise

G_3	S1	S2	S3	S4	S5	S6	Local priority
S1	1	$\frac{135.49}{122.77}$	$\frac{130.35}{122.77}$	$\frac{123.37}{122.77}$	$\frac{124.15}{122.77}$	$\frac{125.39}{122.77}$	0.1722
S2	$\frac{122.77}{135.49}$	1	$\frac{130.35}{135.49}$	$\frac{123.37}{135.49}$	$\frac{124.15}{135.49}$	$\frac{125.39}{135.49}$	0.1561
S3	$\frac{122.77}{130.35}$	$\frac{135.49}{130.35}$	1	$\frac{123.37}{130.35}$	$\frac{124.15}{130.35}$	$\frac{125.39}{130.35}$	0.1622
S4	$\frac{122.77}{123.37}$	$\frac{135.49}{123.37}$	$\frac{130.35}{123.37}$	1	$\frac{124.15}{123.37}$	$\frac{125.39}{123.37}$	0.1714
S5	$\frac{122.77}{124.15}$	$\frac{135.49}{124.15}$	$\frac{130.35}{124.15}$	$\frac{123.37}{124.15}$	1	$\frac{125.39}{124.15}$	0.1695
S6	$\frac{122.77}{125.39}$	$\frac{135.49}{125.39}$	$\frac{130.35}{125.39}$	$\frac{123.37}{125.39}$	$\frac{124.15}{125.39}$	1	0.1686

The weight vector calculated according to formula (27) is as follows:

$$\bar{W}_1 = [0.1614, 0.1754, 0.1714, 0.1624, 0.1634, 0.1660]^T ;$$

$$\bar{W}_2 = [0.1690, 0.1794, 0.1573, 0.1709, 0.1591, 0.1643]^T ;$$

$$\bar{W}_3 = [0.1722, 0.1561, 0.1622, 0.1714, 0.1695, 0.1686]^T .$$

According to comprehensive considerations of the above three indexes, the total hierarchy ordering is acquired as follows based on formula (28):

$$V = \bar{W}U = [0.1699, 0.1689, 0.1603, 0.1705, 0.1642, 0.1662]^T$$

The priority ranking of the designs is:

$$S4 > S1 > S2 > S6 > S5 > S3$$

Therefore, S4 is the optimal scheme.

5.3 Comparisons and discussion

Table 9 Comparisons of optimization results between two designs

Optimal scheme	Design variable					Objective function		
	R (mm)	d (mm)	D (mm)	D_p (mm)	p_0 (MPa)	a (mm)	t (s)	ΔT (°C)
Original parameters	105	40	256	48	2.5	12	11.41	150.57
Weighting method	108.30	52.8764	280	47.95	2.60	12.99	10.68	116.23
NSGA-AHP	115.30	35.96	279.54	44.02	2.90	12.38	10.43	123.37

Based on Table 9 and compared with the original parameters, the thickness of the brake disc in the weighting method is increased by 8.25%; the braking time is shortened by 6.40%; the braking temperature rise is significantly decreased by 22.80%; it has favourable heat fading resistance. Compared with the original parameters, the thickness of the brake disc obtained by the hierarchy decision method is increased by 3.17%; the braking time is shortened by 8.59%; the braking temperature rise is significantly decreased by 18.06%.

The braking time and the thickness of the braking disc acquired from the hierarchy decision method are both smaller than the optimization results acquired from the weighting method; although there is a rise in the braking temperature, it is within the allowable range. The weighting method is greatly dominated by artificial factors; the analytic hierarchy method is utilized to acquire the only group of solutions by quantizing the problem in a scientific way. In addition, the multiple-objective optimization of the disc brake achieved by applying the hierarchy decision method is superior to that achieved with the weighting method.

6. Conclusion

Aiming at the Pareto solution set of the multiple-objective optimization, an NSGA-AHP method is proposed in this paper, which conducts decision making and analysis on the Pareto solution set of the multiple-objective optimization in the structural optimization. In addition, by taking an example of a disc brake, a disc brake multiple-objective optimal model is also developed. Minimum braking time, minimum thickness of the braking disc and minimum temperature rise of the brake disc are taken as the optimization objectives. The multiple-objective optimization is established for the disc brake, and an analysis is conducted on the structural objective by utilizing the NSGA-AHP method. A test and analysis are carried out based on the comparisons with the conventional weighting method. According to the research results, the new method is applicable to the structural optimization of disc brakes; at the same time, it provides a reference for the optimization of other mechanical structures.

The advantages of the NSGA-AHP method are systemic and considerable. It provides an effective judgment about the Pareto set of the NSGA. The disadvantages of the NSGA-AHP method are that the judgment of the scale of the matrix element is done by the designer, and there is certain randomness in the evaluation of the scales of the judgment matrix. This method is applicable to individual decision making but in the case of decisions made by many people, conflicts may arise.

ACKNOWLEDGEMENT

This work study is supported by the Artificial Intelligence Key Laboratory of Sichuan Province under Grant No 2017RYY04 ; the Technology Department of Sichuan Province under Grant No 2017JY0148 ; the Project of Sichuan Provincial Department of Education under Grant No 18ZB0423; the Sichuan Provincial Key Lab of Process Equipment and Control under Grant No GK201806; Educational Commission of Sichuan Province of China under Grant No 17ZA0260; Talent Project of Sichuan University of Science and Engineering under Grant No 2017RCL42.

Nomenclature

a thickness of the brake disc

a_{ij} value of the judgment matrix of the pair-wise comparison between the i^{th} line and the j^{th} line

A index matrix

- B_j judgment matrix
- d diameter of the friction lining
- D diameter of the braking disc
- D_p piston diameter
- E total power consumed by the friction torque between the lining and the brake disc during the braking process
- F the piston thrust of the high pressure oil cylinder
- F_0 force of the whole lining acting on the disc
- $F(\mathbf{x})$ objective function vector
- $f_i(\mathbf{x})$ i^{th} sub-objective function
- g gravitational acceleration
- $g_j(\mathbf{x})$ j^{th} inequality constraint
- H power consumed by friction torque for each rotation of the brake disc during braking
- $h_k(\mathbf{x})$ k^{th} equality constraint
- J mechanical equivalent of heat
- l arc length of the unit
- m number of sub-objective functions
- n_0 number of automobile wheels or brakes
- p number of equality constraints
- R distance between the center of the friction lining pad and the brake disc shaft
- p_0 oil pressure in the brake cylinder
- q number of inequality constraints
- T_f friction torque during braking
- t time needed from the start of the braking to the full stop
- t_f temperature of the brake disc after braking
- t_i initial temperature or air temperature of the brake disc
- U_i relative weight of various factors.
- v initial velocity of the vehicle during braking
- V total hierarchy ordering vector
- w_i sum of the geometric mean
- W_a total weight of the vehicle
- W weight vector
- \overline{W} feature vector matrix
- μ friction coefficient
- c specific heat of the brake disc
- ρ density of the brake disc

REFERENCES

- [1] Das I; Dennis JE. A closer look at drawbacks of minimizing weighted sums of objectives for Pareto set generation in multicriteria optimization problems. *Structural Optimization* **1997**,14: 63-69. <https://doi.org/10.1007/bf01197559>
- [2] Kasprzak E; Lewis K. A Method to Determine Optimal Relative Weights for Pareto Solutions Sets. In, *World Congress of Structural and Multidisciplinary Optimization*; 1999
- [3] Ivvan S; Peña V; Rionda SB et al. The Max-Min algorithm for maximizing the spread of Pareto fronts applied to Multiobjective Structural Optimization. *VelosOltmechntuagr* **2006**:1-3
- [4] Mikhailov L; Knowles J. Priority Elicitation in the AHP by a Pareto Envelope-Based Selection Algorithm. *Lecture Notes in Economics & Mathematical Systems* **2008**,634: 249-257.
- [5] Logist F; Houska B; Diehl M et al. Fast Pareto set generation for nonlinear optimal control problems with multiple objectives. *Structural & Multidisciplinary Optimization* **2010**,42: 591-603. <https://doi.org/10.1007/s00158-010-0506-x>
- [6] Frischknecht BD; Peters DL; Papalambros PY. Pareto set analysis: local measures of objective coupling in multiobjective design optimization. *Structural & Multidisciplinary Optimization* **2011**,43: 617-630. <https://doi.org/10.1007/s00158-010-0599-2>
- [7] Banichuk NV; Ragnedda F; Serra M. Several Examples of Application of Nash and Pareto Approaches to Multiobjective Structural Optimization with Uncertainties. *Mechanics Based Design of Structures & Machines* **2014**,42: 56-69. <https://doi.org/10.1080/15397734.2013.823828>
- [8] Deng W; Zhao H; Zou L et al. A novel collaborative optimization algorithm in solving complex optimization problems. *Soft Computing* **2017**,21: 4387-4398. <https://doi.org/10.1007/s00500-016-2071-8>.
- [9] Jiang S; Lian M; Lu C et al. Ensemble Prediction Algorithm of Anomaly Monitoring Based on Big Data Analysis Platform of Open-Pit Mine Slope. *Complexity* **2018**,1048756: 1-13. <https://doi.org/10.1155/2018/1048756>.
- [10] Zhou J; Du Z; Liao Y et al. An optimization design of vehicle axle system based on multiobjective cooperative optimization algorithm. *Journal of the Chinese Institute of Engineers* **2018**,41: 635-642. <https://doi.org/10.1080/02533839.2018.1534559>.
- [11] Yang XS; Karamanoglu M; He X. Multi-objective Flower Algorithm for Optimization. *Procedia Computer Science* **2013**,18: 861-868. <https://doi.org/10.1016/j.procs.2013.05.251>
- [12] Amouzgar K; Rashid A; Stromberg N. Multi-objective optimization of a disc brake system by using SPEA2 and RBFN. In, *ASME 2013 International Design Engineering Technical Conferences and Computers and Information in Engineering Conference*. Portland, USA: The American Society of Mechanical Engineers; 2013
- [13] Zhang Y; He X. Reliability multi-objective optimization design for caliper disc brake. *China Mechanical Engineering* **2004**,15: 175-177.
- [14] Zhang Y. Reliability-based design for automobiles in China. *Frontiers of Mechanical Engineering in China* **2008**,3: 369-376.
- [15] Karakoc K; Park EJ; Suleman A. Design considerations for an automotive magnetorheological brake. *Mechatronics* **2008**,18: 434-447. <https://doi.org/10.1016/j.mechatronics.2008.02.003>.
- [16] G.Ranjith Kumar ST, M. Rajasekhar Reddy, Dr. G. Harinath Gowd. Design Analysis & Optimization of an Automotive Disc Brake. *International Journal of Advanced Engineering Research and Science* **2014**,1: 24-29.
- [17] Meng GQ;Zhang ZL;Dai RQ. Disc Brake Optimization Design and Finite Element Analysis. *Advanced Materials Research* **2013**,811: 325-330. <https://doi.org/10.4028/www.scientific.net/amr.811.325>
- [18] Yaji K;Kitamura Y;Matsushima T et al. Structural Optimization of a Brake Disc. *Journal of the Japan Society for Precision Engineering* **2014**,80: 763-770. <https://doi.org/10.2493/jjspe.80.763>
- [19] Strömberg N;Rashid A. An Efficient Sequential Approach for Simulation of Thermal Stresses in Disc Brakes. *Nordic Symposium on Tribology, Nordtrib* , **2013**.
- [20] Lü H;Yu D. Optimization design of a disc brake system with hybrid uncertainties. *Advances in Engineering Software* **2016**,98: 112-122. <https://doi.org/10.1016/j.advengsoft.2016.04.009>.
- [21] Committee E. *Automobile Engineering Handbook*. Beijing: People's Communication Edition; 2001
- [22] García-Cascales MS;Lamata MT. Selection of a cleaning system for engine maintenance based on the analytic hierarchy process. *Computers & Industrial Engineering* **2009**,56: 1442-1451. <https://doi.org/10.1016/j.cie.2008.09.015>.

- [23] Hou Y. Optimization Model for Uncertain Statistics Based on an Analytic Hierarchy Process. *Mathematical Problems in Engineering* **2014**,2014: 1-6. <https://doi.org/10.1155/2014/594025>.
- [24] Akbarian D. Ranking All DEA-Efficient DMUs Based on Cross Efficiency and Analytic Hierarchy Process Methods. *Journal of Optimization* **2015**,2015: 1-10. <https://doi.org/10.1155/2015/594727>.
- [25] Singh SP;Prakash T;Singh VP et al. Analytic hierarchy process based automatic generation control of multi-area interconnected power system using Jaya algorithm. *Engineering Applications of Artificial Intelligence* **2017**,60: 35-44. <https://doi.org/10.1016/j.engappai.2017.01.008>.

Submitted: 22.8.2017

Accepted: 08.5.2018

Junchao Zhou
zhou1987g@163.com
School of Mechanical Engineering and
Artificial Intelligence Key Laboratory of
Sichuan Province, Sichuan University of
Science and Engineering, Zigong
Sichuan 643000, P. R. China
Jianjie Gao*
jianjiecq@163.com
Department of Road Traffic Management ,
Sichuan Police College,
Luzhou Sichuan 646000, P. R. China
Kaizhu Wang
School of Mechanical Engineering,
Sichuan University of Science &
Engineering, Zigong Sichuan 643000,
P. R. China
Yinghua Liao
School of Mechanical Engineering,
Sichuan University of Science &
Engineering, Zigong Sichuan 643000,
P. R. China
*Corresponding author,
jianjiecq@163.com