

RESEARCH ON THE REDUCTION OF COOPER SLAG USING AN ALTERNATIVE COAL RANGE

Received – Primljeno: 2019-12-04

Accepted – Prihvaćeno: 2020-03-06

Preliminary Note – Prethodno priopćenje

Blister copper smelting in a flash furnace results in the generation of slag with a Cu content greater than 15 percent. In the process of reduction in an electric furnace, coke or coke breeze is used as a carbon-bearing material. The presented work shows the results of studies on the reduction of the slag with a carbon flotoconcentrate as a substitute for coke breeze. The microstructure, chemical composition and phase composition of slag samples were analyzed. Based on the results of chemical composition of the Cu-Pb-Fe alloy and the post-reduction slag, it was shown that carbon flotoconcentrate might be considered as an alternative for currently used reducers.

Key words: flash furnace, Cu-Pb-Fe, copper slag, carbon flotoconcentrate, reduction

INTRODUCTION

Typical copper slag from the pyrometallurgical production of copper contains about 1 % Cu. Many times of research with the aim from recycling and reusing these slags inducted in the past few decades [1-13]. The one stage Outokumpu process for copper blister combines two technological operations, i.e. smelting of the copper mattes and its converting. The main advantages of this process are the possibility of full utilization of process gases as well as the relatively low unit energy input. On the other hand, the biggest disadvantage of such process is the production of slags with a high copper content (up to 15 % by mass), which processing carried out in the electric furnaces is very expensive. The coke breeze added to the slag as one of the electric furnace feed components, participates in the direct reduction of metal oxides and on the other hand plays role in the formation of CO oxide acting as a gas reducer. One of the possible approaches of reduction of the process costs is to replace coke breeze with a cheaper carbonaceous material, like pellets of coal flotoconcentrate, as shown in the presented work.

MATERIALS

Based on the preliminary works carried out in the resistance furnace. The investigations in the electric furnace were conducted using as a reducer, pellets with flotoconcentrate. Additionally, the comparative tests were run with the coke breeze, i.e. commonly used industrial reducer material. The flash furnace contained 11,6 % wt. Cu; 10,63 % wt. Fe and 3,25 % wt. Pb.

APPARATUS

The experiments were run in a single-electrode arc furnace (Figure 1). Here, the direct high-current arc between the graphite electrode and the liquid workpiece was applied.

Arc heating is electrical heating based on the Joule effect in gases flowing freely into the discharge space. Hence, the arc is primarily heat source, but also a source of electromagnetic radiation and noise. The workpiece is a part of the circuit. The arc was supplied from the transformer (5) lowering the voltage down to 40 V. The arc currents did not exceed 1,2 kA. The graphite electrode (2) had a diameter of 40 mm. The crucible (1) was made of graphite, and was lined with a special refractory material made of high-aluminum refractory cement. Due to this construction, liquid metal and slag did not have direct contact with graphite. At the bottom of the crucible, a molybdenum plate (3) was placed on the

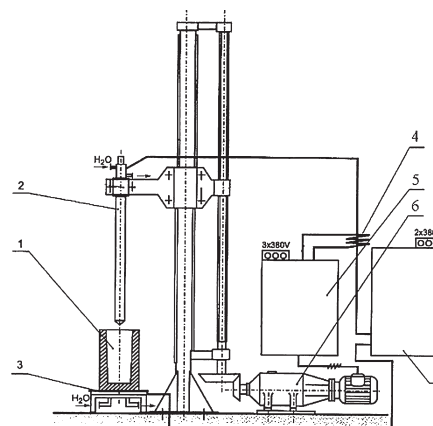

Figure 1 Diagram of a single-electrode arc furnace:
1 - crucible, 2 - graphite electrode, 3 - conducting plate, 4 - measuring system, 5 - power transformer, 6 - drive with speed reducer, 7 - control system

L. Blacha: leszek.blacha@polsl.pl, J. Łabaj, M. Jodkowski, A. Smalcerz - Silesian University of Technology, Faculty of Materials Science, Katowice, Poland

refractory lining, enabling the flow of current. The device also had loading and unloading elements, the cooling system, as well as measuring system (4, 7).

RESEARCH METHODOLOGY

According to research methodology, the copper slag was melted in an induction furnace, after which it was poured into a crucible placed in an electric furnace. The small amount of the same melted slag and technological additives, i.e. a carbon reducer (flotoconcentrate or coal breeze) and limestone were put at the bottom of this crucible. In few cases, an additional layer of carbonaceous material was used, which was placed on the surface of the liquid slag immediately after charging it into the electric furnace. The next step was the introduction of the electrode into the liquid slag and this was set as the beginning of the smelting process. After a specified time, the obtained metal and slag were cast into a ingot mold. The samples of these materials were subjected to chemical analysis in order to determine the content of basic metals, i.e. Cu, Pb and Fe. The initial slag and after the reduction process were subjected to metallographic tests, in order to assess their microstructure, composition and phase. The microstructure, chemical composition and phase composition of each of slag sample was analysed. The first analysis was performed with the use of a HITACHI – 3 400 N scanning microscope (Scanning Electron Microscopy - SEM) fitted with a Thermo Noran energy dispersive x-ray spectrometer (EDS) and an electron probe microanalysis (EPMA) system. The phase composition analysis was carried out by means of the X-ray diffraction (XRD) method using a JEOL JDX-7S diffractometer.

RESULTS AND DISCUSSION

The results of reducing melts carried out in an electric furnace are given below. Table 1 shows the results of tests using a loose-type reducer. Table 2 shows the results of tests conducted using reducing pieces (pellets).

Table 1 **Chemical composition of the Cu-Pb-Fe alloy (reducing agent in loose form)**

Type of reducer	Chemical composition* / % weight		
	Cu	Fe	Pb
coke breeze	70,10	1,34	17,56
coal flotoconcentrate	73,4	2,11	13,34

* mean values

Table 2 **Chemical composition of the Cu-Pb-Fe alloy (reducing agent in pellets)**

Type of reducer	Chemical composition* / % weight		
	Cu	Fe	Pb
coke breeze	73,68	4,14	8,65
coal flotoconcentrate - pellets	83,68	2,45	6,11

* mean values

The obtained results confirm that during the smelting of the flash copper slag to remove Cu and Pb in semi-technical scales in the electric furnace, the coke and coke breeze traditionally used in this process can be effectively replaced with the pellets of coal flotoconcentrate. The observed compositions of Cu-Pb-Fe alloys and the fraction of transition of metals to alloys were within the limits obtained in industrial conditions. The copper and lead contents in the waste slag received in the investigated process were below 0,5% by weight (Table 3).

The characterization of the copper slag microstructure suggest their complex and non-uniform morphology. This is particularly observed in the case of slag particle size, which varied from several hundred nanometers to micrometers. Particle sizes in the tested slags were different for all samples. The morphology of the slag particles also changed, from particles with clearly defined flat surfaces to rounded and spherical ones., as shown in Figures 2, 5, 6.

The analysis of slag sample diffractograms indicate that in the slags, iron mainly occurred in the form of Fe_3O_4 and Fe_2O_3 , while copper was found in the form of Cu_2O (Figures 3, 4)

Table 3 **Chemical composition of waste slag***

Type of reducer	Chemical composition of waste slag* / % weight			Fraction of Cu transferred to alloy Cu-Fe-Pb
	Cu	Fe	Pb	
coke breeze	0,55	10,13	1,18	96,14 - 98,11
coal flotoconcentrate - pellets	0,39	2,56	0,49	96,06 - 98,01

* mean values

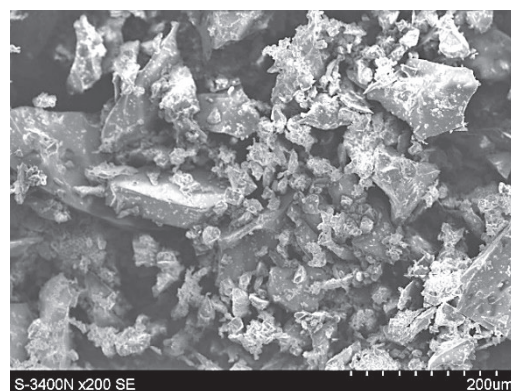
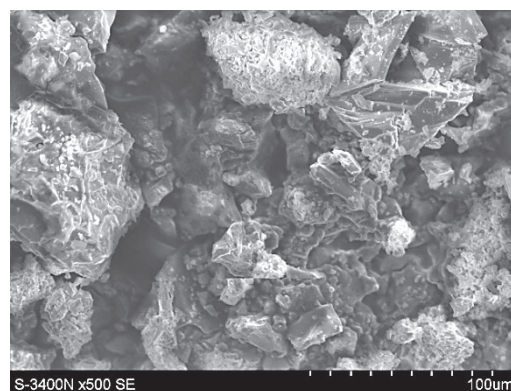

Figure 2 Images of the initial slag microstructure [14]

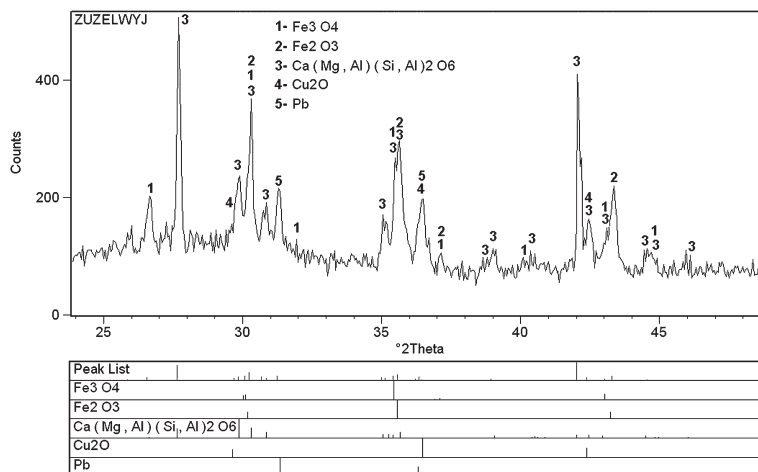

Figure 3 Part of the x-ray diffractogram of the initial slag [15]

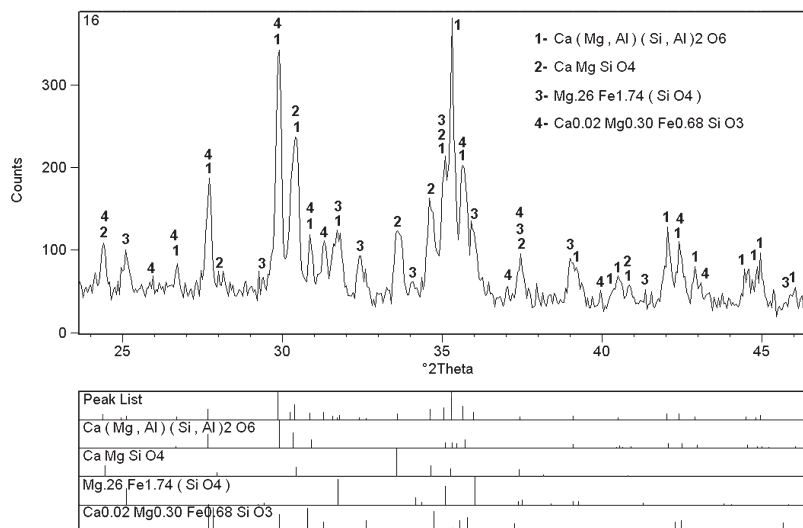

Figure 4 Part of the x-ray diffractogram of the post-reduction slag (reducer coal flotoconcentrate – pellets)

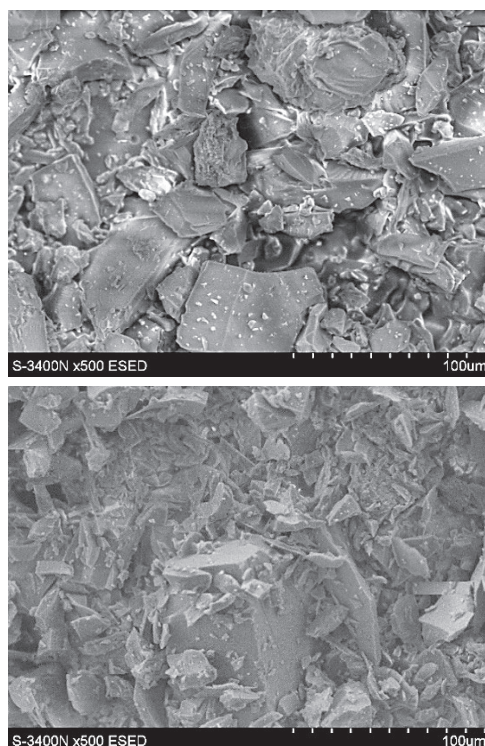
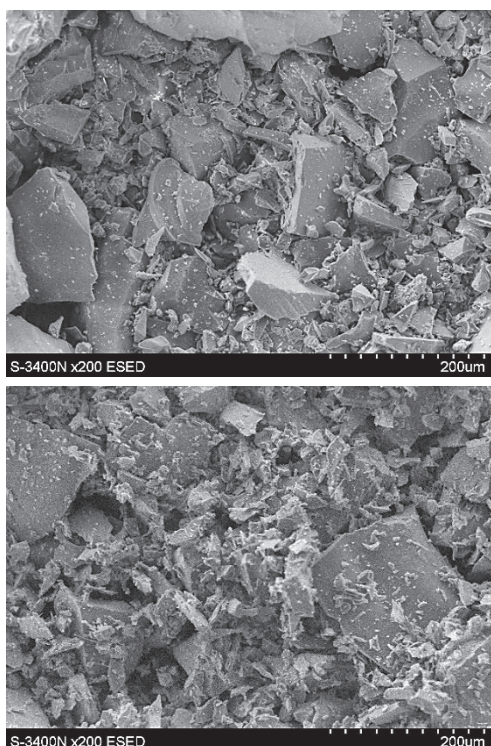

Figure 5 Images of the microstructure post-reduction slag (reducer coal breeze)

Figure 6 Images of the microstructure post-reduction slag (reducer coal flotoconcentrate – pellets)

CONCLUSIONS

- The results of reducing remelting copper flash slag in an electric furnace confirmed the possibility of full replacement of the commonly used coke breeze with carbon float concentrate as reducing agent.
- The obtained compositions of Cu-Pb-Fe alloys and the fraction of transition of metals to alloys were within the limits typically observed in industrial conditions
- Waste slag consisted in below 0,4 weight % for copper and below 0,5 % for lead which made this slag waste material.
- The most beneficial was the introduction of carbon pellets as a component of the lower backfill of the furnace. As the second (top) backfill layer, it is advisable to use coke breeze in the technological process.
- No influence of the type and form of the reducer used on the structure and phase composition of waste slag was observed.

REFERENCES

- [1] Z. Huaiwei, S. Xiaoyan, Z. Bo, H. Xin. Reduction of molten copper slags with mMixed CO-CH₄-Ar gas. *Metallurgical and Materials Transactions B* 45 (2014), 582-589.
- [2] A. Warczok, G. Riveros, P. Echeverría, C.M. Díaz, H. Schwarze, G. Sánchez. Factors governing slag cleaning in an electric furnace. *Canadian Metallurgical Quarterly* 41 (2002), 465-473.
- [3] M. Kucharski, T. Sak, P. Madej, M. Wędrychowicz, W. Mróz. A Study on the copper recovery from the slag of the outokumpu direct-to-copper process. *Metallurgical and Materials Transactions B* 45 (2014), 590-602.
- [4] S. Wang, W. Ni, C.L. Wang, D.Z Li, H.Y. Wang. Study of deep reduction process for iron recovery from copper slag. *Metal Mine* 453 (2014), 156-160.
- [5] Z.K. Li, Y.X. Wen, J. Su. Directive reducing of iron minerals from copper slag with anthracite as reductant. *Inorganic Chemistry: An Indian Journal* 45 (2014), 51-55.
- [6] Y. Wang, R. Zhu, Y.G. Guo, M. Zhou, M.W. Guo, C.F. Zhou. Experimental study on the copper slag reduction process. *Nonferrous Metals* 5 (2014), 61-67.
- [7] H.F. Yang, L.L. Jing, C Dang. Iron recovery from copper-slag with lignite-based direct reduction followed by magnetic separation. *Chinese Journal of Nonferrous Metal* 21 (2011), 1165-1170.
- [8] K. Rogóż, M. Kucharski. *Kinetyka redukcji żużla z procesu zawieszinowego z zastosowaniem różnych postaci reduktora grafitowego*. Wydawnictwo Naukowe AKAPIT. Kraków (2010) 83-93.
- [9] M. Kucharski. Effect of thermodynamic and physical properties of flash smelting slags on copper losses during slag cleaning in an electrical furnace. *Archives of Metallurgy* 32 (1987) 3, 307-319.
- [10] S. Zhou, Y. Wei, S. Zhang, N. Li, H.Wang, Y. Yang, M. Baratic. Reduction of copper smelting slag using waste coking oil. *Journal of Cleaner Production* 236 (2019), 1-10.
- [11] P. Sarfo, A. Das, G. Wyss, C. Young. Recovery of metal values from copper slag and reuse of residual secondary slag. *Waste Management* 70 (2017), 272-281.
- [12] L. Li. Study on smelting reduction ironmaking of copper slag. *The Chinese Journal of Process Engineering* 11 (2011) 1, 65-71.
- [13] T. Rzychoń, T. Matuła, B. Chmiela, J. Łabaj, K. Rogóż. Modifications of the chemical composition and microstructure of flash smelting cooper slags in the process of their reduction. *Metalurgija* 54 (2015) 1, 151-153.
- [14] G. Siwec, M. Sozańska, L. Blacha, A. Smalcerz. Behaviour of iron during reduction of slag obtained from cooper flash smelting. *Metalurgija* 54 (2015) 1, 113-115.

Note: The responsible translator for English language is Ling House. Poland.