

Automatika

Journal for Control, Measurement, Electronics, Computing and Communications



ISSN: 0005-1144 (Print) 1848-3380 (Online) Journal homepage: <https://www.tandfonline.com/loi/taut20>

Analysis of time delays in scheduled and unscheduled communication used in process automation

S. M. A. K. Azad & K. Srinivasan

To cite this article: S. M. A. K. Azad & K. Srinivasan (2020) Analysis of time delays in scheduled and unscheduled communication used in process automation, *Automatika*, 61:1, 109-116, DOI: [10.1080/00051144.2019.1687194](https://doi.org/10.1080/00051144.2019.1687194)

To link to this article: <https://doi.org/10.1080/00051144.2019.1687194>



© 2019 The Author(s). Published by Informa UK Limited, trading as Taylor & Francis Group



Published online: 10 Nov 2019.



Submit your article to this journal [↗](#)



Article views: 246



View related articles [↗](#)



View Crossmark data [↗](#)



Analysis of time delays in scheduled and unscheduled communication used in process automation

S. M. A. K. Azad and K. Srinivasan

Department of Instrumentation and Control Engineering, National Institute of Technology, Trichy, India

ABSTRACT

This paper introduces a network model for analysing the time delays of scheduled and unscheduled communication services among field devices used in process automation. The proposed model is implemented by configuring multiple control loops of real-time field devices into a network. The consensus of the network is designed using segment checker™ simulation software. The simulated network of the field devices is re-configured for the proposed network model by mapping virtually. Every device is treated as a node in the network model and the real-time data is accessed. The time delays recorded for both scheduled and unscheduled communication of field-bus topology in simulation environment and the performance is compared with scheduled communication delay. The better bandwidth utilization and assignment of field device is achieved by introducing the unscheduled communication time delays in the network. It helps in the improvement of network capacity by accommodating more devices and reduces the commissioning cost.

ARTICLE HISTORY

Received 10 February 2018
Accepted 29 October 2019

KEYWORDS

Industrial communication;
communication protocols;
networked control systems;
delay systems; scheduling;
data acquisition

1. Introduction

The real-time communication among the devices connected in a network is becoming more challenging in industrial control process automation. The communication or accessing the data is generally categorized as scheduled and unscheduled communication. Scheduled communication, sometimes also known as periodic service is a type of real-time data access in which time for data transfer is fixed. Unscheduled communication, also known as aperiodic service is priority-based data access during maintenance of the network configured with several field devices. The combination of scheduled and unscheduled establishes complete communication in a control loop. The time delays in the data access are very much essential for maintaining the better performance of the network.

Till now, many literature have been studied different methods on the scheduled communication with time delay. In 1979, Kuehn started scheduled services for data analysis in the multi-queue system with continuous cyclic service [1]. Further, Levy and Siddi used scheduled services with time delays for modelling and optimization for polling systems [2]. This cyclic service system is extended to discrete-time analysis with gated service by Dittmann and Hubner [3]. Furthermore, Tovar et al. has developed analytical models for token passing based systems by again utilizing the scheduled communication [4].

Foundation Fieldbus (FF) is one of the popular field buses used to access real-time data in process control applications [5]. FF incorporates the Data link layer (DLL) for the token-passing protocol in both scheduled and unscheduled communication among multiple devices establishing a dynamic network [5]. Scheduling the devices on the network for real-time data access is related to time response of the device and data transmission rate. The presence of the time delay in the network reduces the performance of the network and leads the process out of control. The analysis of time delays has become more essential in all event-based system to maintain better results of transmission when multiple closed-loop systems are shared on a network to send real-time data with their corresponding controllers.

The research on the time delay in control communication of the process industry is limited to only periodic service in the literature [6–11]. Hong et al. introduced a bandwidth allocation scheme for FF which has self-diagnostics features [12,13] with scheduled data in DLL of FF [14]. Further, Hong et al. continued the evaluation of bandwidth allocation for FF [15]. In 2004, Tian et al. discussed the stability of Internet congestion control with diverse delays [16]. Though the research extended to multi-agent systems with a time delay approach but still limited to scheduled service only [17,18]. As FF

DLL works on token passing service, the transmission of urgent, normal and time available data with priority to get more flexible data transmission [11]. Hong Hee Lee and Seung Ho Hong introduced the concept of virtual token rotation time (VTTRT) for improving the delay analysis [19]. Real-time data transfer in time token protocol is categorized into synchronous and asynchronous messages. The data is periodic and being accessed at regular intervals is termed as synchronous and the messages are non-periodic and have no delivery time constraints are termed as asynchronous messages [20]. The concept of scheduled communication is revolted towards sampled-data synchronization for complex dynamical network in which the probabilistic delays and deterministic time-varying delay with the stochastic parameter by constructing a new Lyapunov – Krasovskii function [21]. Then researchers started working on the performance of the network with many techniques and for instance, Bianchi's approximation technique to analyse the performance of a network of adaptive event-based systems to a higher accurate degree [22]. The field of scheduled services then directed with event-triggered control methods for integrating the average consensus problem in multi-agent systems [23]. The existence of time delays in data transition among agents is considered as undirected and connected with graph theory. Large and continuous networks with mixed mode-dependent time delays have been investigated by finite-time synchronization with Lyapunov–Krasovskii function [24] and the analysis on both the constant and fast varying delays has done depending on decreasing Lyapunov–Krasovskii function [25].

From the above literature survey, it is found that the analysis of time delays is essential for network communication to improve performance. The above literature fails to include unscheduled communication services and its time delay. A mathematical model for analysing the delay time for critical data in FF introduced by Hong and Jang [7] was based on assumptions that token rotation time is independent and identical random variable [26] is not considered for unscheduled time delays. The Present paper introduces a network model for the analysis of delay time in both scheduled and unscheduled services for the FF network designed with a network simulator to get a more realistic approach. The time delays are compared with the proposed model and mathematical model. In this paper, the unscheduled events are generated with a priority at random time during scheduled service. When the network is accessed for unscheduled service, the scheduled service waits and delay increased. The total time of transmission with time delays are recorded for a particular TTRT. It is found that the saturation of the delay at TTRT increased in the present network model compared with the mathematical models of the literature. The improved delay time analysis helps in adjusting the configuration of the

segment with devices interconnected for better bandwidth allocation.

2. Foundation Fieldbus

Foundation Fieldbus (FF) is one of the leading communication protocol used for remote control in industrial process automation. FF is a digital and multi-drop communication that supports interoperability where FF devices are operated remotely. Transmitter or actuator with a control unit embedded in it is called a smart device, used to control the process remotely [26]. The FF communication protocol is similar to the OSI model with four layers out of which, data link layer (DLL) plays a vital role in accessing the data. The configuration of Foundation Fieldbus devices and their medium access satisfies IEC61158 standards. FF is a communication channel between the DeviceNet and Host system (Control System) for measuring the process value of multiple control loops connected in the network for a specified time slot [27]. The typical architecture of the communication network for FF is as shown in Figure 1.

In process control system, the configuration of FF is done by anyone of the host systems like programmable logic controller (PLC), distributed control system (DCS), etc. The interfacing of the host system with the FF segment through medium access control is supported by link active scheduler (LAS). An FF network is categorized into four segments and each segment can accommodate a minimum number of 2 FF devices and a maximum number of 32 FF devices. Scheduling the time period among the devices for real-time data access over the network is a challenging task. Each control loop executes and publishes the data with a transmission speed of 31.25Kbps for a fixed time period in periodic data transfer of a DLL in FF called Actual Token Rotation Time (ATRT) [19]. Urgent transmission of data is a priority-based access of a network during configuration of the new FF device for maintenance purpose and the time required by a token for urgent transmission of priority-based data is called Virtual Token Rotation Time (VTTRT) [19]. In practical applications of process control, the FF network is reserved for a particular duration of time to complete urgent data transfer besides periodic data messages known as target token rotation time (TTRT). The sum of ATRT and VTTRT should not exceed the target token rotation time, TTRT. Scheduling of medium access for real-time data transmission among FF devices is controlled by link active scheduler (LAS). In case of failure of LAS, FF devices with LAS functionalities will take care of the medium access control and those FF devices are called Link master devices (LMDs) whereas basic devices (BDs) are used for only data acquisition [5,18]. There exists a latency during control transfer from active mode to standby mode of LAS during the failure of active LAS [2]. Based on the FF segment design,

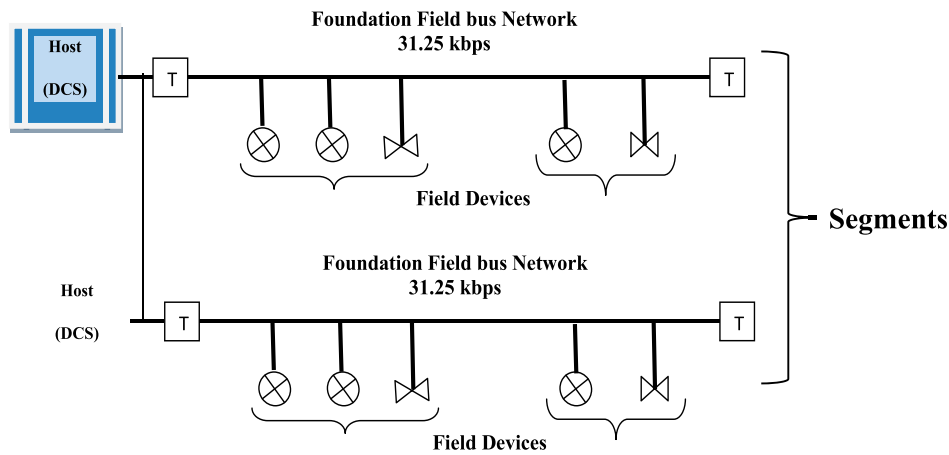

Figure 1. Schematic diagram of Foundation Fieldbus Segment.

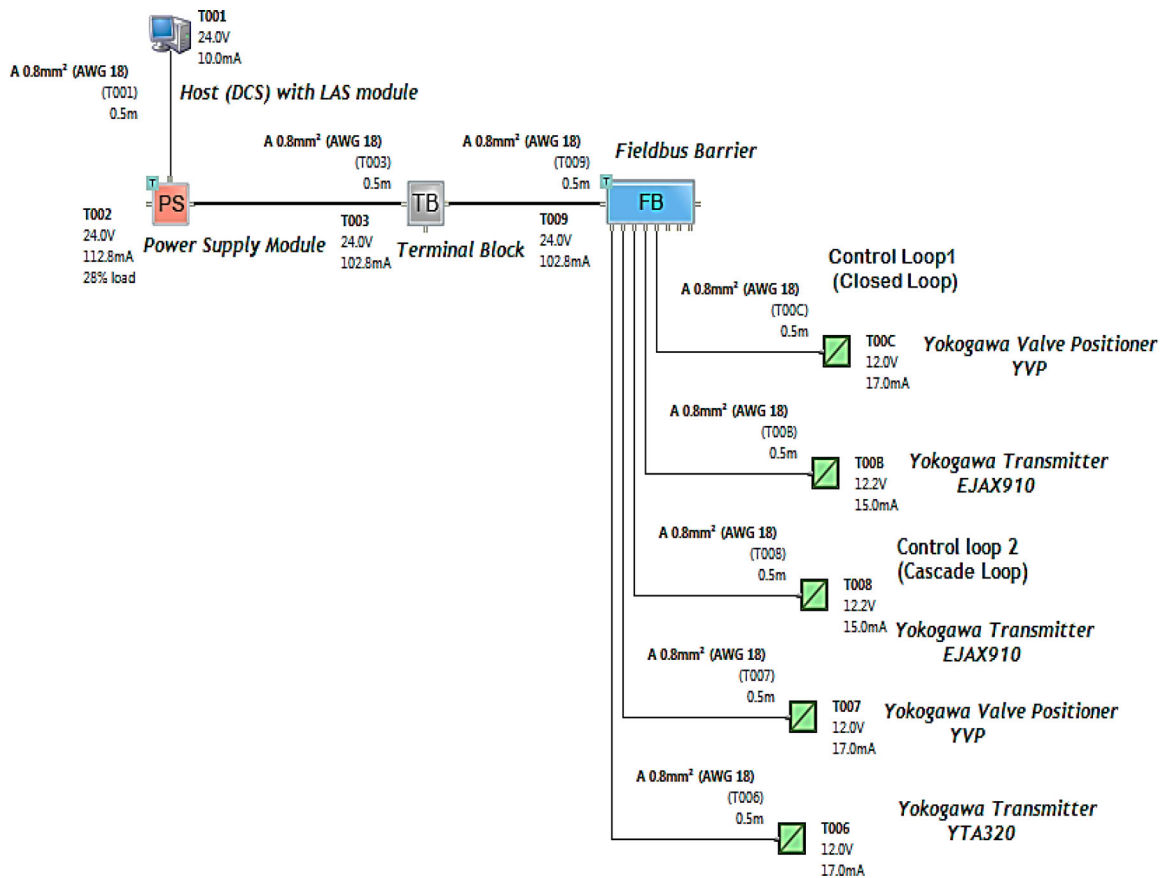

Figure 2. Simulation of FF segment.

the topology of the network is validated using a segment checker simulation in section III.

3. FF segment model

The segment considered for the proposed model is designed in segment checkerTM for control loops with FF devices as shown in Figure 2. In scheduled communication, two message frames namely a pass token (Pt) and compels data (Cd) transmits by LAS to the basic devices for passing a token. The LAS sends the Cd message frame when scheduled service initiated by the control loop in a segment. The BD that receives

the Cd message frame starts transmitting the real-time data packet of periodic message and returns the token to LAS. In unscheduled service, the token passing service includes event triggered data transmission based on priority. The priorities are categorized as “0” for time critical and “1” for the time available respectively, and priority 1 is high as it is used for data access, the configuration of FF devices and another maintenance purpose [18]. The LAS evaluates ATRT for every complete cycle of transmitting the pass token frames to all the devices in a segment of the FF network and estimates the TTRT. The accuracy in the estimation of TTRT helps in the optimization of the network time

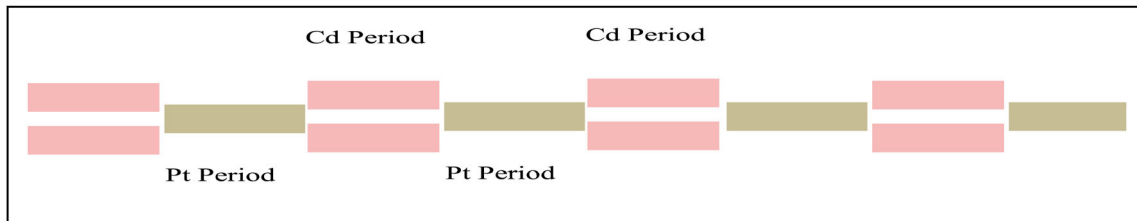

Figure 3. Band width allocation of segment.

and improves the configuration of the number of FF devices on each segment so that commissioning cost is reduced to a greater extent. In order to analyse the optimal time, the study of the delay time in FF is much more essential. The proposed network model gives a realistic approach for finding the time delays for both scheduled and unscheduled services with real-time FF devices connected in a segment.

As Fieldbus is constrained to a rate of 31.25 Kbps, the only way to transmit additional information is to increase the cycle time. Bandwidth allocation for the segment model is shown in Figure 3. Bandwidth for periodic data transmission is purely based on the BD or LMD configured to the segment with the corresponding address in a segment. The total bandwidth required can be estimated using the formula as shown in Equation (1).

$$T_L = (N_p + N_c) * 50 \quad (1)$$

where T_L is time to execute all function blocks in loops, N_p is the number of devices on the network, N_c is number of communications with the HMI

As per the statistics, the significant percentage of communication on H1 network relies on unscheduled communication and the minimum event-based communication time is 70% to 80% for a newly commissioned segment. Scheduled traffic time may be determined by the summation of the individual function block execution time and the publish time on the network. The Execution time of FF devices used for the proposed network is tabulated in Table 1. Network-based FF segment model is developed in section IV, configuring all the FF devices as nodes in the segment. The delay times and the network topology is incorporated in the model for better analysis.

4. Proposed network model

Hong and Ko developed a simulation model [8] and Kelton et al. developed ARENA in 2002 [9] on FF network to investigate network performance characteristics. Later in 2010, Lee and Hong developed a computer simulation model [18] using event scheduling scheme. Cassandras and Lafortune introduced discrete time systems for event scheduling developed in C# and run by PC [17]. However, the schemes involved in

Table 1. Execution Time of FF network devices.

Device	Tag	Execution Time (ms)
Host System (PID circulation time)	Not Applicable	15
Compel Data Device 1 – AI (Analog input)	Not Applicable (Temperature Transmitter) TT-1	25
Device 2 – PID	(Temperature Controller) TC-1	90
Device 3 – PID	(Pressure Controller) PC-2	80
Device 4 – PID	(Temperature Control Valve) TCV-1	40
Device 5 – AO (Analog Output)	(Pressure Valve) PV-2	75

previous research are purely based on the mathematical approach with static time delays. Also, simulation results on C# fail to introduce the unscheduled time delay to develop real-time model of the Data Link Layer of the FF Segment. The present network-based model is developed for the FF segment as per the standards of Foundation Fieldbus for a better analysis of time critical and time available data transmission services. The network model is derived from the FF segment simulation of Figure 2 and all the FF devices are configured as the nodes in the network simulator (NS2) environment with real-time parameters of FF devices for scheduled and unscheduled data transmission as shown in Figure 5. The network simulator provides the real-time approach to measure the time delay for all network topologies with more accuracy in real-time applications [8,21,28]. This simulator is exclusively used to measure the delay time of data transmission in different communication protocols [21,28]. In the proposed network model, two control loops are configured with five FF devices and their description is given in Table 2. The host device is labelled as T001 in the segment model is mapped as node “0” and named as LAS in the network model.

Similarly, the tags T006, T007, T008, T00B and T00C in the segment model are mapped with the nodes 3,5,4,1 and 2 respectively constituting multi-agent control loops on the network. Also, it is assumed that the tags T002, T003, and T009 as dummy nodes in the segment model are not configured in the network model as these nodes do not offer any delays on the network. The Mapping of tags with corresponding segment devices is tabulated in Table 2. Bus topology and token passing service are embedded among the nodes created in the

Table 2. FF Devices with Model and Tag Names of Proposed Segment.

Device model	Device type	Quantity	Tag name	Network model nodes
EJX910	Yokogawa Flow Transmitter	2	T00B,T008	1 and 4
Host	(DCS) LAS	1	T001	0
Power Supply	Power Supply Module (24.0 V)	1	T002	NA*
R4D0-FB-IA8	Fieldbus Barrier	1	T009	NA*
Terminal Block	Terminal Block Module	1	T003	NA*
YTA320	Yokogawa Temperature Transmitter	1	T006	3
YVP	Yokogawa Valve Positioner	2	T00C,T007	2 and 5

Note: *Not applicable.

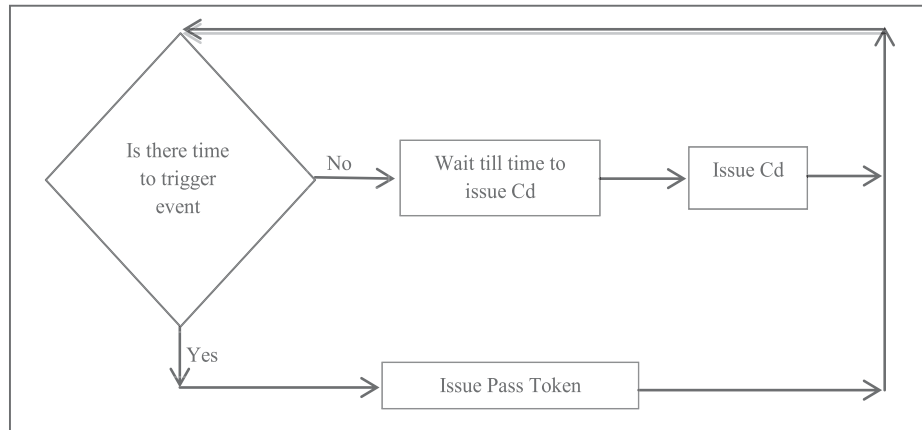
**Figure 4.** Flow chart of LAS used in network model.

proposed network. Scheduled data transmission occurs once LAS starts sending token and Compel data to one of the basic device, say “BD1” in a segment and BD1 receives token “Pt” and returns the token with the data packet to LAS. The allocation of time slots for Cd and Pt is explained in Figure 3 which is known as Bandwidth. During this transmission of data between any two nodes, the other nodes can not access the network but, they can execute internally and wait for the next Cd. The flow of token transmission on the network is described in the flow chart of Figure 4. It has assumed that when time critical or scheduled service

is commenced, no other data transmission is allowed except event based or unscheduled service since it is considered as high priority services. Both priorities are considered and the effect of performance is discussed in this paper.

5. Results and discussions

The results obtained from the proposed network model of the FF segment are compared with the results obtained from the mathematical model of Hong and Jang [7], a simulation model of Hong and Ko [8] and the

**Figure 5.** Network model in network simulator.

Table 3. Network parameters for delay investigation.

b_0 (ms)	b_1 (ms)	l_0 (ms^{-1})	l_1 (ms^{-1})	T_0 (ms)
19.2	68.352	0.00057	0.00016	410.1/600

revised mathematical model of Yong H. Lee and Seung Ho Hong [18]. With respect to the FF segment, network model is developed using network simulator and the delays for both time critical and time available services as shown in Figure 5. The time delays of both time critical and time available data are functions of TTRT irrespective of the number of priority queues since the priority is considered as either “1” or “0” for LAS provides token passing service. The network parameters used for the mathematical model [11] shown in Table 3 are considered for the present network-based model in this paper for a better comparison of the results.

The traffic load on network is defined as in Equation (2)

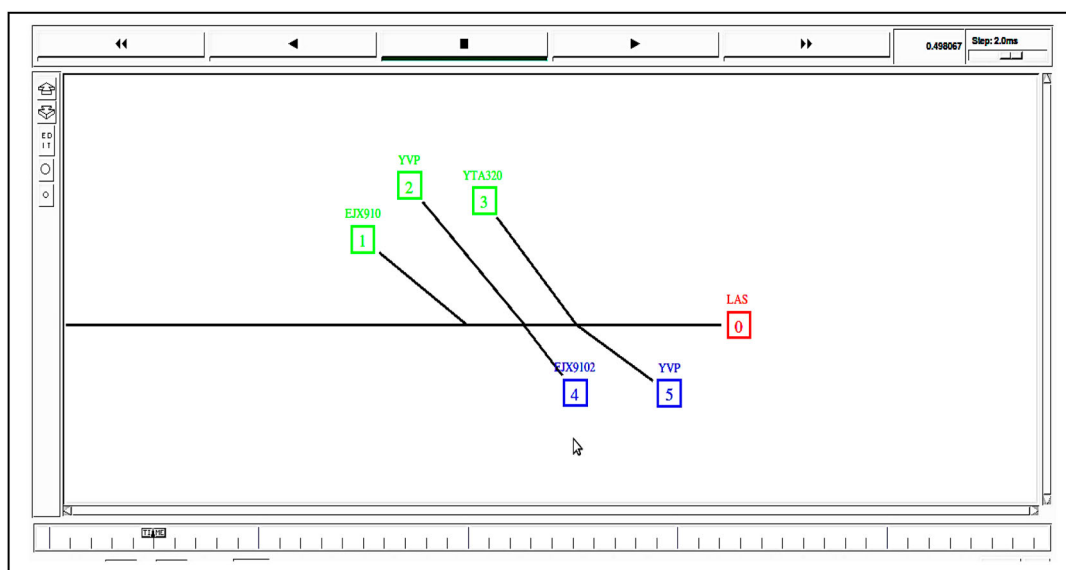
$$T_L = a_0 l_0 b_0 + a_1 l_1 b_1 \quad (2)$$

where a , number of both priority queue; a_0 , number of priority “0” queue; a_1 , number of priority “1” queue; l_0 , arrival rate of priority “0”; l_1 , Arrival rate of priority “1”; T_L , Traffic Load; b_0 , Transmission time of period of priority “0”; b_1 , Transmission time of period of priority “1”; $T_0 = D_r + D_p$, Token overhead time of a token, D_r , Residual delay; D_p , Propagation delay.

For network model,

$$T_L = a(l_0 b_0 + l_1 b_1) \quad (3)$$

In the present network model, $a = a_0 = a_1$ as the traffic load is purely depending on the arrival rate of

priorities, but not on the number of priorities. It is observed that “ a ” is almost same for the priority queues from the network model simulation and T_L is proportional to the sum of products of arrival rate and transmission period for both priorities.

The comparison of time delays with reference to TTRT of network-based model (NBM) with simulation model (SM) [11], mathematical model (HJMM) [8] and revised mathematical model (LHMM) [10] are shown in Figure 6 for time-critical data and in Figure 7 for time available data respectively. In [11], when TTRT is less than $T_0 = 410.1$ ms only time-critical data is transmitted with a delay of 570 ms whereas, from NBM, it is observed that till TTRT reaches $T_0 = 700$ ms, the time-critical data are transmitted with the delay time as per schedule in the network. When TTRT is greater than 700 ms, the FF network is allowed to share time available data based on unscheduled communication as the event triggered by accessing live list data which results in an increase in delay time at that instant.

Also, TTRT at 1000 ms, the time delay for time-critical data service is 560 ms for LHMM and HJMM whereas 470 ms for NBM. Again at 1500 ms of TTRT, the time delay for time-critical data service is 540 ms for LHMM and HJMM whereas, 620 ms for NBM. The slight difference of 90 and 80 ms is observed till 1500 ms of TTRT. After 1500 ms, the delay time starts saturating for LHMM and LHMM as the time delays are fixed and scheduled for all control loops. But in the case of NBM, the delay time continues to increase as the delays are dynamic due to the existence of events on the network.

Saturation starts after 2000 ms of TTRT for NBM which is observed in Figure 6. In case of time available data service, a small change in TTRT effects more delay

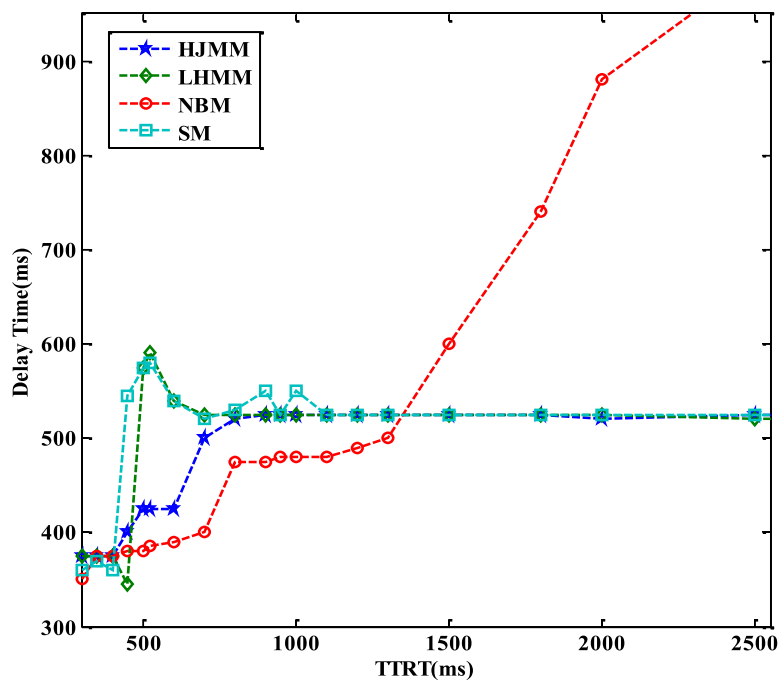
**Figure 6.** Delay of time-critical data.

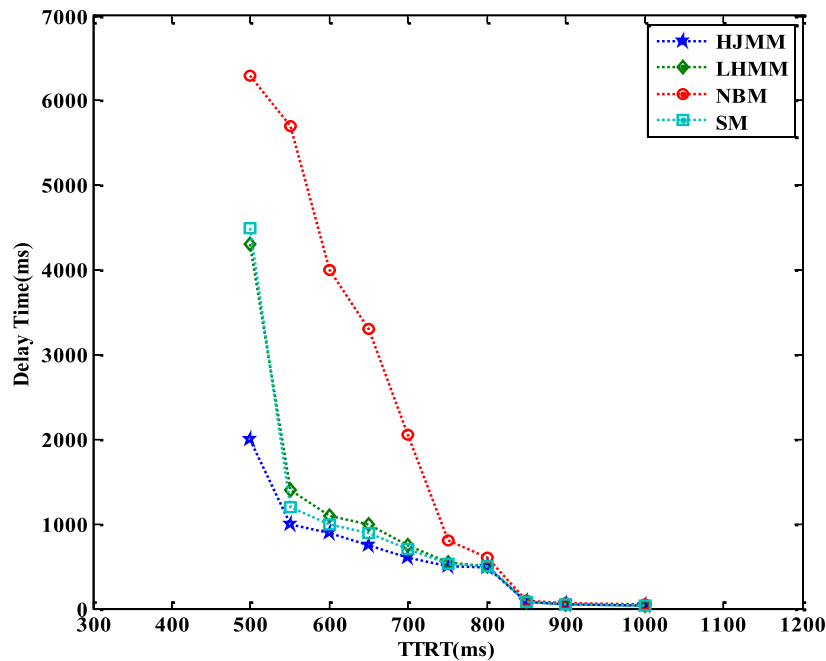

Figure 7. Delay time of time available data.

time for LHMM, HJMM and SM which is observed in Figure 7. When TTRT is around 500 ms, the delay time for LHMM, HJMM and SM reaches their maximum of 4400, 2000 and 4600 ms respectively whereas for NBM the maximum time delay is 6400 ms. It is also observed in the simulation model that the traffic load increases with the number of nodes in the network. But in practice, the number of nodes in the FF segment is designed in such a way that the increase in traffic load is negligible as the data transmission on the network is allowed only between one node to LAS or node to node at a time. No other node is allowed to publish the data on the network during the data transmission in DLL of FF. In general, TTRT is fixed for an FF segment accommodating a minimum of 2 devices to a maximum of 32 devices. The configuration of devices is improved with the optimal allocation of the delays which is achieved with the analysis of based model analysis.

6. Conclusion and future work

The Proposed network-based model used for time delay analysis of a network segment for FF is simulated by introducing unscheduled communication and scheduled services in real-time data transmission. Unlike the previous study in [8,10,11], the proposed network model introduced unscheduled communication in addition to scheduled communication to evaluate the time delays in time critical and time available data. The time delays for time critical and time available services are analysed and compared with the mathematical and simulation models. It is found that the difference in delay time is countable for TTRT greater than 700 and 1000 ms respectively. The time delay saturation points at TTRT are discussed and the validation of the

network model segment is done using the network simulator. The Bandwidth improvement will be achieved by using the proposed approach which helps in accommodating more field devices and hence it reduces the installation cost.

Disclosure statement

No potential conflict of interest was reported by the authors.

ORCID

S. M. A. K. Azad  <http://orcid.org/0000-0003-0517-2488>

References

- [1] Kuehn PJ. Multiqueue systems with nonexhaustive cyclic service. *Bell Syst Tech J.* 1979;58(3):671–698.
- [2] Levy H, Sidi M. Polling systems: applications, modeling, and optimization. *IEEE Trans Commun.* 1990;38(10):1750–1760.
- [3] Dittmann R, Hübner F. Discrete-time analysis of a cyclic service system with gated limited service. 1993.
- [4] Tovar E, Vasques F, Burns A. Supporting real-time distributed computer-controlled systems with multi-hop P-NET networks. *Control Eng Pract.* 1999;7(8):1015–1025.
- [5] Specifications, F. O. U. N. D. A. T. I. O. N. T. M. Data link protocol specifications. 1997.
- [6] Åström KJ, Bernhardsson B. Comparison of periodic and event based sampling for first-order stochastic systems. In *Proceedings of the 14th IFAC World congress*, 11; Citeseer; 1999. pp. 301–306
- [7] Hong SH, Jang BD. Time-critical data transmission in the Foundation Fieldbus. In *ISIE 2001. 2001 IEEE International Symposium on Industrial Electronics Proceedings (Cat. No. 01TH8570)*, 1, IEEE; 2001. pp. 555–559.
- [8] Hong SH, Ko SJ. A simulation study on the performance analysis of the data link layer of IEC/ISA fieldbus. *Simulation.* 2001;76(2):109–118.

- [9] Kelton WD. Simulation with ARENA. McGraw-hill; 2002.
- [10] Otanez PG, Moyne JR, Tilbury DM. Using deadbands to reduce communication in networked control systems. In Proceedings of the 2002 American Control Conference (IEEE Cat. No. CH37301), 4, IEEE; 2002. pp. 3015–3020.
- [11] Wang J, Zhang S, Maple C. Guaranteeing the timely transmission of periodic messages with arbitrary deadline constraints using the timed token media access control protocol. IET Commun. 2011;5(4):519–533.
- [12] Tian Y-P, Liu C-L. Consensus of multi-agent systems with diverse input and communication delays. IEEE Trans Automat Contr. 2008;53(9):2122–2128.
- [13] Lin P, Jia Y. Average consensus in networks of multi-agents with both switching topology and coupling time-delay. Physica A. 2008;387(1):303–313.
- [14] Pinceti P. Fieldbus: more than a communication link. IEEE Instrum Meas Mag. 2004;7(1):17–23.
- [15] Hong SH, Choi IH. Experimental evaluation of a bandwidth allocation scheme for foundation fieldbus. In IMTC 2001. Proceedings of the 18th IEEE Instrumentation and Measurement Technology Conference. Rediscovering Measurement in the Age of Informatics (Cat. No. 01CH 37188), 2, IEEE; 2001. pp. 833–838.
- [16] Tian Y-P, Yang H-Y. Stability of the Internet congestion control with diverse delays. Automatica (Oxf). 2004;40(9):1533–1541.
- [17] Cassandras CG, Lafortune S. Introduction to discrete event systems. Springer Science & Business Media; 2009.
- [18] Lee YH, Hong SH. Dependency on prioritized data in the delay analysis of foundation fieldbus. Control Eng Pract. 2010;18(8):845–851.
- [19] Verhappen I, Pereira A. Foundation Fieldbus. ISA; 2008.
- [20] Rakkiyappan R, Sakthivel N. Pinning sampled-data control for synchronization of complex networks with probabilistic time-varying delays using quadratic convex approach. Neurocomputing. 2015;162:26–40.
- [21] Luo Q, Wang J, Wang X, et al. Aero-Sim: an NS-2 based simulator for aeronautical Ad Hoc networks. KSII T Internet Info. 2015;9(7):2548–2567.
- [22] Ramesh C, Sandberg H, Johansson KH. Performance analysis of a network of event-based systems. IEEE Trans Automat Contr. 2016;61(11):3568–3573.
- [23] Wang A. Event-based consensus control for single-integrator networks with communication time delays. Neurocomputing. 2016;173:1715–1719.
- [24] Li B, Chen Z-q, Liu Z-x, et al. Containment control of multi-agent systems with fixed time-delays in fixed directed networks. Neurocomputing. 2016;173:2069–2075.
- [25] Schiffer J, Dörfler F, Fridman E. Robustness of distributed averaging control in power systems: time delays & dynamic communication topology. Automatica (Oxf). 2017;80:261–271.
- [26] Lavrov KG, et al. Development of FOUNDATION TM Fieldbus technology for coke oven plants. Coke and Chemistry. 2018;61(7):270–273.
- [27] Foundation FB H1 design specification. Segment Checker. pepperl + Fuchs. 2001.
- [28] Mishra V, Jangale S. Analysis and comparison of different network simulators. IJAIEM. 2014.