

# METODA PRORAČUNA MTU SIGNALA U 110 KV MREŽI A METHOD FOR CALCULATING THE RIPPLE CONTROL SIGNAL IN A 110 KV NETWORK

Lahorko Wagmann - Srđan Žutobradić - Milan Puharić, Zagreb,  
Hrvatska

U članku je prikazana metoda proračuna širenja MTU signala u 110 kV mreži. Opisan je frekvencijski ovisan model mreže za proračun širenja MTU signala. Prezentirana je usporedba rezultata proračuna širenja MTU signala s rezultatima odgovarajućih mjerenja u mreži 110 kV.

In the article, a method is presented for the calculation of the propagation of the ripple control signal in a 110 kV network. A frequency dependent network model is described for the calculation of the propagation of the ripple control signal. A comparison of the results of the calculation of the propagation of the ripple control signal and the results of corresponding measurements in a 110 kV network are presented.

**Ključne riječi:** frekvencijska domena, model mreže, mrežno ton-frekvencijsko upravljanje energije.

**Key words:** frequency domain, network model, ripple control

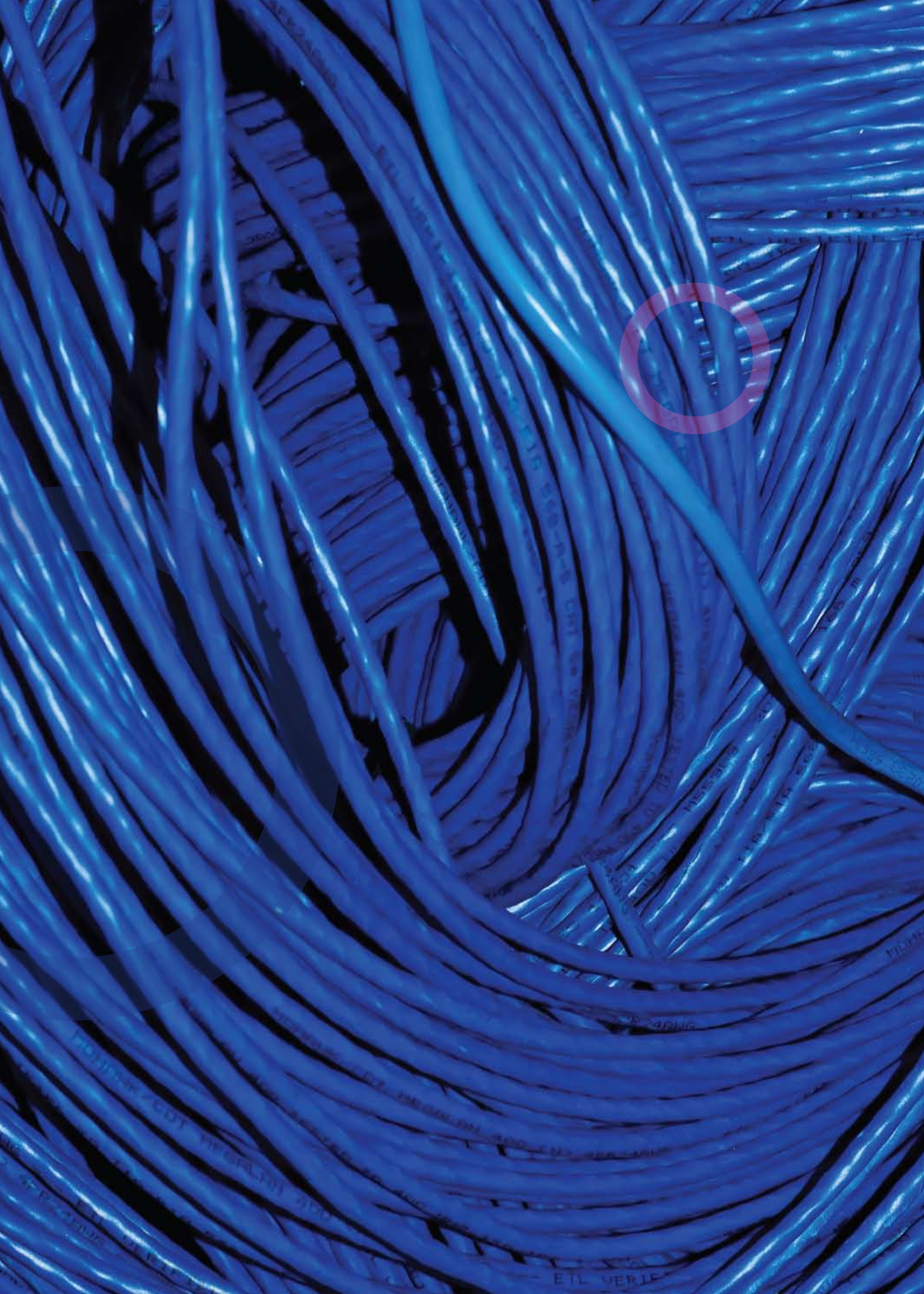



## 1 UVOD

Mrežno ton-frekvencijsko upravljanje (MTU) jedna je od najrasprostranjenijih metoda za upravljanje brojilima u elektrodistribucijskom sustavu. Do nedavno je u Hrvatskoj postojao tek MTU sustav s injektiranjem na srednjonaponskoj razini. Situacija se tek nedavno promijenila ugradnjom dvaju postrojenja na naponskoj razini 110 kV, jednog u Zagrebu (TS Botinec) i jednog u Splitu (TS Vrboran). Pritom, takvo tehničko rješenje otvara mnoga pitanja u pogledu odabira najpovoljnije lokacije postrojenja, tehničke izvedivosti, potrebne snage i ostalih parametara postrojenja, jačine MTU signala u svim čvorištima mreže, međusobnog utjecaja MTU signala i komponenta mreže, kao što su posebice paralelni filtri, itd.

Kako bi se na takva pitanja moglo odgovoriti, potrebno je prije ugradnje samog postrojenja za utiskivanje MTU signala, još u fazi planiranja čitavog sustava, napraviti proračune širenja MTU signala. Proračun širenja MTU signala dakle, služi za određivanje značajki MTU postrojenja, odabir najpovoljnije lokacije MTU odašiljača u mreži, odabir najpovoljnije frekvencije za utiskivanje MTU signala, procjene pokrivenosti mreže MTU signalom te ocjene utjecaja pojedinih parametara elektroenergetskog sustava [1] i [2].

Za proračun širenja MTU signala potrebno je imati nadomjesnu shemu mreže koja uvažava frekvencijsku ovisnost realnih i imaginarnih dijelova impedancije pojedinih elemenata mreže, slično kao i kod proračuna širenja harmonika. Naročito važan utjecaj na točnost proračuna širenja MTU signala ima model opterećenja, zbog toga što se u modelu mreže javlja kao poprečni element, koji ima najveći utjecaj na iznos Theveninove impedancije pa samim time i na iznos izračunatog MTU signala.

Budući da su nakon izgradnje postrojenja za utiskivanje MTU signala u spomenute 110 kV transformatorske stanice napravljena mjerenja signala u čvorovima 110 kV mreže, omogućena je i usporedba rezultata proračuna s izmjerenim veličinama MTU signala. Usporedbom izmjerenih i proračunatih vrijednosti verificira se model mreže i metoda proračuna MTU signala u 110 kV mreži. Temeljem prikazanog modela proračuna napravljen je i poseban modul za proračun MTU signala kao dodatak programskom paketu NetHarmo v.5.0, koji se inače koristi za proračun širenja harmonika u elektroenergetskim mrežama. Navedeni programski paket omogućuje jednostavnu

## 1 INTRODUCTION

Ripple control is one of the most widely used methods for the control of meters in electrical distribution systems. Until recently in Croatia, there was only a ripple control system installed at the medium voltage level. The situation has recently changed with the construction of two plants at the voltage level of 110 kV, one in Zagreb (Botinec Substation) and one in Split (Vrboran Substation). Such a technical solution opens many questions in respect to the choice of the most suitable locations for the plants, technical feasibility, the necessary power rating and other parameters of the plants, the strength of the ripple control signal in all the network nodes, interaction between the ripple control signal and the network components, particularly parallel filters etc.

In order to be able to answer such questions, it is necessary to calculate the propagation of the ripple control signal during the planning phase of the entire system before installing the plant for the injection of the ripple control signal. Calculation of the propagation of the ripple control signal is therefore used for the determination of the properties of the ripple control signal and evaluation of the most suitable locations for the injection of the ripple control signal into the network, the selection of the most suitable frequency of the injection signal, estimation of the signal coverage area, and evaluation of the impact of individual parameters of the power system [1] and [2].

For the calculation of the propagation of the ripple control signal, it is necessary to have an equivalent circuit diagram of the network that takes into account the frequency dependence of the real and imaginary parts of the impedance of individual elements of the network, as in the calculation of the propagation of the harmonics. The load model has a particularly important influence upon the precision of the calculation of the propagation of the ripple control signal because it appears as a transverse component in the network model, which has the greatest impact on the value of Thevenin impedance and, therefore, on the value of the calculated ripple control signal.

Since signal measurement was performed in the nodes of the 110 kV network following the construction of the plants for the injection of the ripple control signal in the previously mentioned 110 kV substations, it was possible to compare the results of the calculation with the measured values of the ripple control signal. By comparing the measured and calculated values, the network model and method for the calculation of the ripple control signal in the 110 kV network are verified. Based upon the calculation model presented, a special module was devised for the calculation of the ripple control signal as supple-

analizu mreže s ciljem iznalaženja optimalnog tehničkog rješenja ugradnje MTU utiskivačkog postrojenja [1].

Načelo rada MTU slično je širenju radio signala s tom razlikom što se za prijenos signala koristi elektroenergetska mreža. Utiskivanje signala može se ostvariti paralelnim ili serijskim spojem na mrežu na visokom, srednjem ili niskom naponu. Tonfrekvencijski signal utiskuje se u mrežu pomoću odgovarajućih spojnih filtara ugođenih na određenu MTU frekvenciju. Kodirani signal unutar određenog dosega primaju MTU prijarnici koji su ugođeni na određenu MTU frekvenciju. Oni primljeni signal prevode u odgovarajuće upravljačke sklopne operacije, kao što je upravljanje tarifama, upravljanje potrošnjom, itd.

## 2 OPIS METODE ZA PRORAČUN ŠIRENJA MTU SIGNALA

Proračun širenja MTU signala radi se zbog određivanja značajki MTU postrojenja, odabira najpovoljnije lokacije odašiljača u mreži, procjene pokrivenosti mreže MTU signalom, ocjene utjecaja pojedinih parametara elektroenergetskog sustava. Za proračun širenja MTU signala u elektroenergetskoj mreži potrebne su dvije vrste proračuna. Prva je proračun frekvencijskog odziva mreže, kod kojeg se računa matrica impedancija čvorova za sve frekvencije od 50 Hz do 2 500 Hz u koracima od po 10 Hz (slika 1).

ment to the software package NetHarmo v.5.0, which is otherwise used for the calculation of the propagation of harmonics in power networks. This software package facilities simple analysis of a network with the goal of analyzing the optimal technical solution for the construction of ripple injection plants [1].

The principle of the operation of a ripple control system is similar to the propagation of a radio signal, with the difference that a power network is used for the transmission of the signal. Injection of the signal into the network can be achieved by a parallel or serial connection at high, medium or low voltage. The tone frequency signal is injected into the network using the suitable coupling filters tuned to a specific ripple control frequency. The coded signal within a certain range is received by ripple control receivers tuned to a specific ripple control frequency. They translate the signal received into respective control and switching operations, such as tariff management, consumption management etc.

## 2 DESCRIPTION OF A METHOD FOR THE CALCULATION OF THE PROPAGATION OF A RIPPLE CONTROL SIGNAL

The calculation of the propagation of a ripple control signal is performed in order to determine the characteristics of a ripple control plant, select the most suitable locations for transmitters in the network, estimate the signal coverage area and evaluate the impact of individual parameters of the power system. For the calculation of the propagation of the ripple control signal in a power network, two types of calculation are necessary. The first is the calculation of the frequency response of the network, whereby the node impedance matrix for all the frequencies from 50 Hz to 2 500 Hz is calculated in increments of 10 Hz (Figure 1).

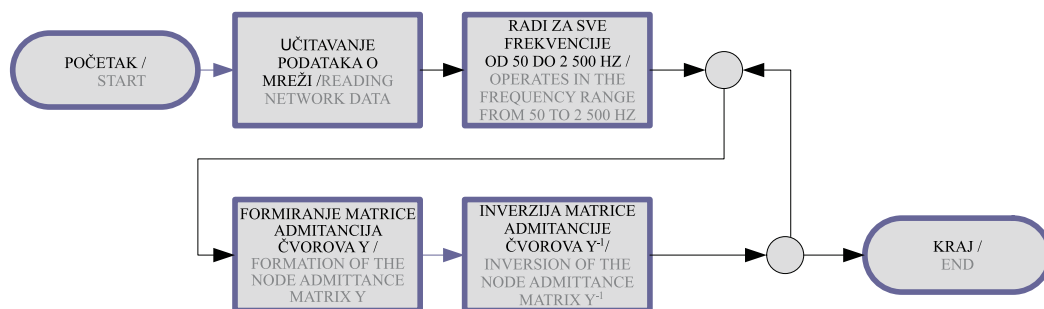

Slika 1 – Dijagram toka programa za proračun frekvencijskog odziva mreže  
Figure 1 – Program flow diagram for the calculation of the network frequency response

Proračunom frekvencijskog odziva mreže dobiva se za svaki čvor ovisnost iznosa i kuta Theveninove impedancije o frekvenciji, temeljem koje je moguće nacrtati anvelopu vektora impedancije u dijagramu s realnom i imaginarnom koordinatom, takozvani locus dijagram. Matrična jednadžba prema kojoj se računa Theveninova impedancija je:

By calculating the frequency response of the network, the relation between magnitude and phase angle of the Thevenin impedance as a function of frequency is obtained for every node, on the basis of which it is possible to draw an envelope curve of impedance vectors in a diagram with real and imaginary coordinates, a so-called locus diagram. The matrix equation according to which Thevenin impedance is calculated is as follows:

$$\begin{aligned} \mathbf{Z}_f &= \mathbf{Y}_f^{-1}, \\ f &= 50, 60, \dots, 2\,500 \text{ Hz}, \end{aligned} \tag{1}$$

gdje su:

$\mathbf{Z}_f$  - matrica impedancija čvorova za frekvenciju  $[\Omega]$ ,  
 $\mathbf{Y}_f$  - matrica admitancija čvorova za frekvenciju [S],  
 $f$  - frekvencija [Hz].

where:

$\mathbf{Z}_f$  - node impedance matrix for frequency  $[\Omega]$ ,  
 $\mathbf{Y}_f$  - node admittance matrix for frequency [S],  
 $f$  - frequency [Hz].

Drugim riječima do Theveninovih impedancija čvorova dolazi se inverzijom matrice admitancija, koja se dobiva koristeći prvi Kirchoff-ov zakon, postavljanjem jednadžbi za sve čvorove promatrane mreže:

In other words, it is possible to arrive at the Thevenin impedance of nodes with an inverse admittance matrix, which is obtained using Kirchoff's first law, writing equations for all four nodes of the network studied:

$$\begin{aligned} Y_{11} \cdot V_1 + Y_{12} \cdot V_2 + \dots + Y_{1n} \cdot V_n &= I_1 \\ Y_{21} \cdot V_1 + Y_{22} \cdot V_2 + \dots + Y_{2n} \cdot V_n &= I_2 \\ \dots & \\ Y_{n1} \cdot V_1 + Y_{n2} \cdot V_2 + \dots + Y_{nn} \cdot V_n &= I_n \end{aligned} \tag{2}$$

gdje su:

$n$  - broj čvorova u mreži,  
 $Y_{ij}$  - admitancija između čvorova  $i$  i  $j$  [S],  
 $V_i$  - napon  $i$ -tog čvora prema referentnom čvoru [V],  
 $I_i$  - struja  $j$ -tog čvora [A].

where:

$n$  - number of network nodes,  
 $Y_{ij}$  - admittance between nodes  $i$  and  $j$  [S],  
 $V_i$  - voltage between the  $i$ -th node and the reference node [V],  
 $I_i$  - current of the  $j$ -th node [A].

Struje  $I_1, \dots, I_n$  jednake su nuli osim u čvoru u kojem je MTU postrojenje. Naponi čvorova  $V_1, \dots, V_n$  su naponi MTU signala koji se određuju rješavanjem sustava  $n$  jednadžbi s  $n$  nepoznanica. Kod proračuna mreže računalima, praktično je jednadžbe mreže (2) moguće napisati u matričnom obliku.

Currents  $I_1, \dots, I_n$  are equal to zero except in the node with the ripple control plant. The voltages of the nodes  $V_1, \dots, V_n$  are the voltages of the ripple control signal that are determined by solving the system of  $n$  equations with  $n$  unknowns. It is practical to write the network equation (2) in matrix form when computers are used for the calculation of network parameters.

$$\begin{pmatrix} I_1 \\ I_2 \\ \cdot \\ \cdot \\ I_n \end{pmatrix} = \begin{pmatrix} Y_{11} & Y_{12} & \dots & Y_{1n} \\ Y_{21} & Y_{22} & \dots & Y_{2n} \\ \dots & \dots & \dots & \dots \\ Y_{n1} & Y_{n2} & \dots & Y_{nn} \end{pmatrix} \times \begin{pmatrix} V_1 \\ V_2 \\ \cdot \\ \cdot \\ V_n \end{pmatrix} \quad (3)$$

Gornja jednačba se simbolički piše kao:

The above equation is symbolically written as follows:

$$I = Y \times V \quad (4)$$

Matrica admitancija čvorišta  $Y$  je kvadratna matrica  $n \times n$ , gdje je  $n$  broj nezavisnih čvorišta u mreži. Članovi matrice admitancije čvorova dobivaju se na sljedeći način:

- dijagonalni član matrice admitancije čvorišta  $Y_{ij}$ ,  $i = 1, 2, \dots, n$ , jednak je sumi admitancija grana koje su vezane za  $i$ -to čvorište te se naziva vlastita admitancija čvorišta,
- izvandijagonalni član matrice admitancije čvorišta  $Y_{ij}$ ,  $i = 1, 2, \dots, n$ ,  $j = 1, 2, \dots, n$ ,  $i \neq j$ , jednak je negativnoj admitanciji grane koja povezuje čvorište  $i$  s čvorištem  $j$ .

Druga vrsta proračuna je analiza širenja MTU signala i određivanje njegove razine u svakom čvoru elektroenergetske mreže. Dijagram toka za proračun širenja MTU signala u elektroenergetskoj mreži prikazan je na slici 2.

The node admittance matrix  $Y$  is an  $n \times n$  square matrix, where  $n$  is the number of independent nodes in the network. Elements of the node admittance matrix are obtained in the following manner:

- the diagonal elements of the node admittance matrix  $Y_{ij}$ ,  $i = 1, 2, \dots, n$ , are equal to the sum of the admittances of the branches that are connected to the  $i$ -th node and are called node self admittances,
- the out of diagonal elements of the node admittance matrix  $Y_{ij}$ ,  $i = 1, 2, \dots, n$ ,  $j = 1, 2, \dots, n$ ,  $i \neq j$ , are equal to the negative admittance of a branch that connects node  $i$  to  $j$  node .

The second type of calculation is the analysis of the propagation of the ripple control signal and the determination of its level in every node of the power network. A flow diagram for the calculation of the propagation of the ripple control signal in a power network is presented in Figure 2.

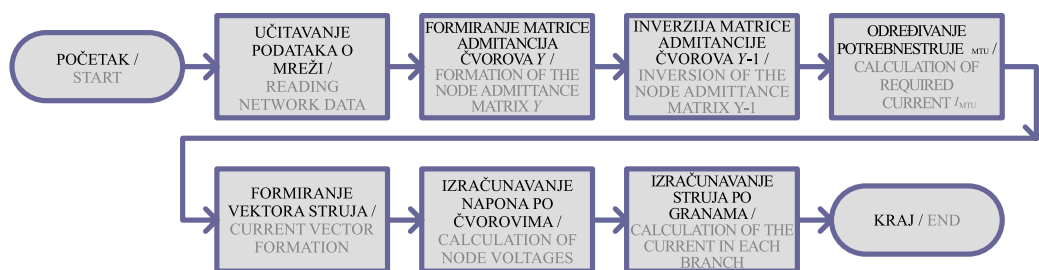

Slika 2 – Dijagram toka programa za širenje MTU signala

Figure 2 – Program flow diagram for the calculation of the propagation of the ripple control signal MTU

Ovim se proračunom prvo izračunava Theveninova impedancija mreže čvora u kojem se nalazi MTU postrojenje. Na temelju željene razine signala i Theveninove impedancije čvora izračunava se potrebni iznos struje MTU odašiljača, odnosno potrebna snaga postrojenja. Načelna shema utiskivanja MTU signala na 110 kV prikazana je na slici 3.

In this calculation, the Thevenin impedance of the network node with the ripple control plant is calculated first. On the basis of the desired signal level and the Thevenin impedance of the node, the required current of the ripple control transmitter is calculated, i.e. the required current of the ripple control plant. The principal diagram of the injection of the ripple control signal into 110 kV is presented in Figure 3.

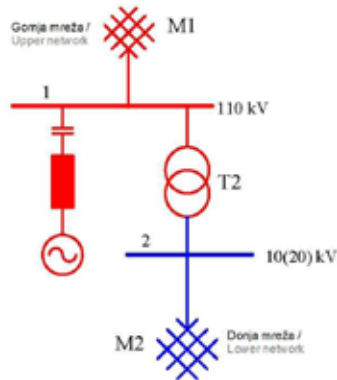

Slika 3 – Utiskivanje MTU signala na 110 kV  
Figure 3 – Injection of the ripple control signal MTU into 110 kV

Gornja se shema može nadomjestiti pomoću impedancija kao na slici 4.

The above diagram can be presented using impedances, as in Figure 4.

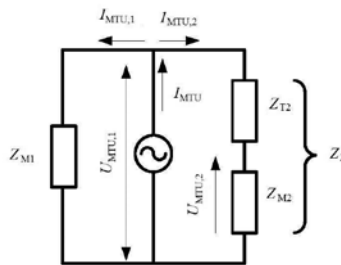

Slika 4 – Model proračuna MTU signala  
Figure 4 – Model of the calculation of the ripple control signal MTU

Ukoliko je razina signala određena u postocima potrebna struja signala određuje se na sljedeći način:

If the signal level is specified in percentages, it is necessary to determine the current of the signal in the following manner:

$$I_{MTU} = \frac{u_{MTU\%}}{100} \frac{U}{\sqrt{3}Z_{uk}} \quad [A], \quad (5)$$

gdje su:

where:

$u_{MTU\%}$  – zadana jačina signala u postocima nominalnog napona,  
 $U$  – referentni napon [kV],  
 $Z_{uk}$  – ukupna impedancija mreže [ $\Omega$ ].

$u_{MTU\%}$  – the given strength of the signal as a % of the rated voltage,  
 $U$  – reference voltage [kV],  
 $Z_{uk}$  – total network impedance [ $\Omega$ ].

Ukupna impedancija mreže u kompleksnom obliku određena je izrazom:

$$Z_{uk} = \frac{Z_{M1} \cdot Z_2}{Z_{M1} + Z_2} [\Omega], \quad (6)$$

$$Z_2 = Z_{T2} + Z_{M2} [\Omega], \quad (7)$$

gdje su:

$Z_{T2}$  – Impedancija transformatora preračunata na referentni napon  $[\Omega]$ ,  
 $Z_{M1}$  – Impedancija mreže višeg napona  $[\Omega]$ ,  
 $Z_{M2}$  – Impedancija mreže nižeg napona  $[\Omega]$ .

Struja MTU signala jednaka je zbroju struja koje odlaze u mrežu višeg i mrežu nižeg napona:

where:

$Z_{T2}$  – Impedance of the voltage transformer  $[\Omega]$ ,  
 $Z_{M1}$  – Impedance of the high voltage network  $[\Omega]$ ,  
 $Z_{M2}$  – Impedance of the low voltage network  $[\Omega]$ .

The current of the ripple control signal is equal to the sum of all the currents flowing out into the high and low voltage networks:

$$I_{MTU} = I_{MTU,1} + I_{MTU,2} [A]. \quad (8)$$

Omjer struja obrnuto je proporcionalan omjeru ukupnih impedancija mreže višeg i mreže nižeg napona:

The currents ratio is inversely proportional to the total high voltage and low voltage network impedances:

$$\frac{|I_{MTU,1}|}{|I_{MTU,2}|} = \frac{|Z_2|}{|Z_1|} \quad (9)$$

Budući da je ukupna impedancija mreže višeg napona dosta niža od ukupne impedancije mreže nižeg napona, većina signala odlazi u mrežu višeg napona. Impedancija mreže  $Z_{M2}$  smanjuje se s porastom opterećenja, što znači da će omjer struja biti povoljniji pri većem opterećenju mreže, ali će i potrebna snaga utiskivanja biti veća. Potrebna snaga utiskivanja izračunava se pomoću formule:

Since total high voltage network impedance is considerably lower than the total low voltage network impedance, most of the signal goes into the high voltage network. Network impedance  $Z_{M2}$  decreases with an increase in the load, which means that the current ratio will be more favorable when there is a higher network load, but the required injection power will be greater. The required injection power is calculated using the following formula:

$$S_{MTU} = \sqrt{3} |U_{MTU}| \cdot |I_{MTU}| [kVA]. \quad (10)$$

Tako izračunata struja uvrštava se u matricnu jednadžbu (3) i nakon njezinog rješavanja, dobivaju se iznosi razina napona MTU signala po svim čvorovima u elektroenergetskoj mreži. Invertiranjem matrice admitancija čvorova i množenjem s vektorom struja dobivaju se vrijednosti napona u svim čvorovima:

The current calculated in this way is inserted in the matrix equation (3). The solution to the equation yields the amounts of the voltage levels of the ripple control signal for all the nodes in the power network. By inverting the node admittance matrix and multiplying it by the current vectors, the voltage values in all the nodes are obtained:



$$\mathbf{Y}^{-1} \cdot \mathbf{I} = \mathbf{V} \quad (11)$$

Ukoliko se unaprijed zna snaga MTU odašiljačkog postrojenja moguće je u proračunu zadati struju MTU signala (npr. 150 A na 110 kV). To znači da ukoliko se željena razina signala postavi previsoko, a izračunata potrebna struja odašiljača bude viša od najveće zadane struje, program će MTU signal izračunati uz zadano ograničenje struje.

Struje u granama računaju se na sljedeći način:

In the calculation, it is possible to set the value of the ripple control current, e.g. 150 A at 110 kV, if the power rating of the ripple control plant is known in advance. This means that if the desired signal level is set too high and the calculated current required is higher than the maximum set current, the program will calculate the ripple control signal under the set limit.

Currents in branches are calculated in the following manner:

$$I_{ij} = (V_i - V_j) \cdot Y_{ij} \quad (12)$$

$$i = 1, 2, \dots, n, \quad j = 1, 2, \dots, n, \quad i \neq j,$$

gdje su:

$V_i$  – napon u  $i$ -tom čvoru [V],  
 $V_j$  – napon u  $j$ -tom čvoru [V],  
 $Y_{ij}$  – admitancija promatrane grane [S],  
 $i, j$  – indeks čvorova,  
 $n$  – broj čvorova.

where:

$V_i$  – voltage in the  $i$ -th node [V],  
 $V_j$  – voltage in the  $j$ -th node [V],  
 $Y_{ij}$  – admittance of the observed branch [S],  
 $i, j$  – node index,  
 $n$  – number of nodes.

### 3 MODELIRANJE MREŽE ZA PRORAČUN ŠIRENJA MTU SIGNALA

Za proračun širenja MTU signala potrebno je imati nadomjesnu shemu mreže koja uvažava frekvenzijsku ovisnost realnih i imaginarnih dijelova impedancije pojedinih elemenata mreže, slično kao i kod proračuna širenja harmonika. Pri promatranju širenja MTU signala uobičajeno je mrežu modelirati u direktnom sustavu simetričnih komponenata.

#### 3.1 Nadzemni vodovi i kabeli

Nadzemni vodovi i kabeli na nazivnoj se frekvenciji nadomještaju konvencionalnom  $\pi$ -shemom, koja sadrži radni i jalovi induktivni otpor serijski spojen između dva čvora, uz poprečno spojene kapacitete (slika 5a).

### 3 MODELING A NETWORK FOR THE CALCULATION OF THE PROPAGATION OF THE RIPPLE CONTROL SIGNAL

For the calculation of the propagation of the ripple control signal, it is necessary to have an equivalent diagram of the network that takes into account the frequency dependence of the real and imaginary parts of the impedance of individual network elements, similar to the calculation of the propagation of harmonics. When studying the propagation of a ripple control signal, it is customary to model the network in the direct system using the method of symmetrical components

#### 3.1 Overhead lines and cables

Overhead lines and cables at rated frequency are represented by the equivalent  $\pi$ -diagram, which contains active and reactive inductive resistance connected in series between two nodes, and capacitances connected in parallel (Figure 5a).

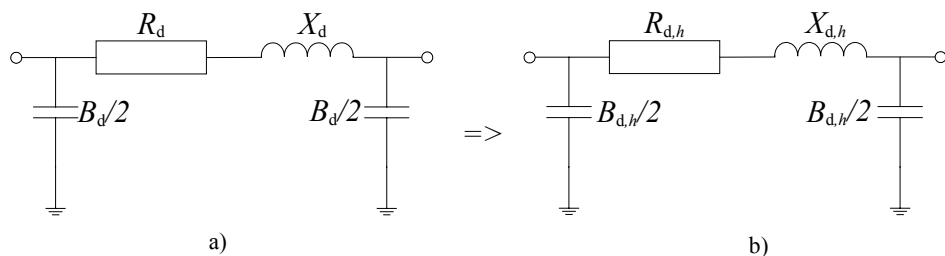

Slika 5 – Nadomjesna shema voda  
Figure 5 – An equivalent circuit of a power line

Na frekvencijama višim od nazivne, parametri voda mijenjaju se na sljedeći način:

At frequencies higher than the rated frequency, the parameters of the line change in the following manner:

$$R_{d,h} = \sqrt{h} \cdot R_d \quad [\Omega/\text{km}], \quad (13)$$

$$X_{d,h} = h \cdot X_d \quad [\Omega/\text{km}], \quad (14)$$

$$B_{d,h} = h \cdot B_d \quad [\text{S}/\text{km}], \quad (15)$$

gdje su:

where:

$R_d$  – jedinični radni otpor voda u direktnom sustavu  $[\Omega/\text{km}]$ ,

$R_d$  – per unit active resistance of a line in the direct system  $[\Omega/\text{km}]$ ,

$X_d$  – jedinična uzdužna reaktancija voda u direktnom sustavu  $[\Omega/\text{km}]$ ,

$X_d$  – per unit longitudinal reactance of a line in a direct system  $[\Omega/\text{km}]$ ,

$B_d$  – jedinična poprečna susceptancija voda u direktnom sustavu  $[\text{S}/\text{km}]$ .

$B_d$  – per unit transverse susceptance of a line in a direct system  $[\text{S}/\text{km}]$ .

Uzdužna impedancija cijele duljine promatranog voda u direktnom sustavu iznosi (slika 5b):

The transversal impedance of the entire length of the line studied in the direct system is as follows (Figure 5b):

$$Z_{d,h} = l \cdot R_{d,h} + j(l \cdot X_{d,h}) = l \cdot \sqrt{h} \cdot R_d + j(l \cdot h \cdot X_d) \quad [\Omega/\text{km}], \quad (16)$$

gdje su:

where:

$l$  – duljina voda  $[\text{km}]$ ,

$l$  – the length of the line  $[\text{km}]$ ,

$h$  – omjer promatrane i nazivne frekvencije.

$h$  – the ratio of the observed and the rated frequency.

Poprečna admitancija cijele duljine voda također se mijenja u ovisnosti o frekvenciji na sljedeći način:

The transversal admittance of the entire length of the line also varies, as a function of the frequency, as follows:

$$\frac{Y_{d,h}}{2} = j \left( l \cdot \frac{B_{d,h}}{2} \right) = j \left( l \cdot h \cdot \frac{B_d}{2} \right) \quad [\text{S}/\text{km}], \quad (17)$$

### 3.2 Model dugog voda

Kod dugih vodova na frekvencijama višim od nazivne, zbog valnog karaktera struje i napona, model voda s koncentriranim parametrima više ne zadovoljava. U takvim slučajevima vod se nadomješta s nekoliko serijski spojenih  $\pi$ -shema. Na taj način dobivaju se točnije vrijednosti napona i struja u proračunu. Tri  $\pi$ -sheme daju točnost do 1,2 % za četvrtinu valne duljine (1 500 km za 50 Hz). S porastom frekvencije potreban broj  $\pi$ -shema proporcionalno raste. Vod od 300 km zahtijeva 30  $\pi$ -shema da bi se postigla točnost od 1,2% za 50-ti harmonik. Blizu rezonantne frekvencije točnost modela drastično opada. Umjesto serijskog spajanja više  $\pi$ -shema, učinkovitije je računati s tzv. točnom, odnosno korigiranom  $\pi$ -shemom.

Vrijednosti impedancije i admitancije u direktnom sustavu množe se korekcijskim faktorima:

$$Z_{\pi,d,h} = Z_{\pi,i,h} = Z_{d,h} \frac{\text{sh} \theta_{d,h}}{\theta_{d,h}} \quad [\Omega], \quad (18)$$

$$\frac{Y_{\pi,d,h}}{2} = \frac{Y_{\pi,i,h}}{2} = \frac{Y_{d,h}}{2} \frac{\text{th} \left( \frac{\theta_{d,h}}{2} \right)}{\frac{\theta_{d,h}}{2}} \quad [\text{S}], \quad (19)$$

gdje su:

$Z_{d,h}$  – tavu na promatranoj frekvenciji [ $\Omega$ ],  
 $Y_{d,h}$  – poprečna admitancija voda u direktnom sustavu na promatranoj frekvenciji [S],  
 $\theta$  – bezdimenzionalna veličina.

Konstanta prodiranja ili valna konstanta voda na promatranoj frekvenciji iznosi:

where:

$Z_{d,h}$  – longitudinal line impedance in the direct system at the observed frequency [ $\Omega$ ],  
 $Y_{d,h}$  – transversal line admittance in the direct system at the observed frequency [S],  
 $\theta$  – nondimensional parameter.

The penetration constant or wave constant of the line at the observed frequency is as follows:

$$\gamma_{d,h} = \gamma_{i,h} = \sqrt{Z_{d,h} \cdot Y_{d,h}} \quad [1/\text{km}], \quad (20)$$

U računu je zgodno uzeti veličinu bez dimenzije:

In the calculation, it is convenient to use the non-dimensional parameter:

$$\theta = l \cdot \gamma, \quad (21)$$

gdje je:

$l$  – duljina voda [km].

where:

$l$  – the length of the line [km].

### 3.3 Sinkroni strojevi

Sinkroni stroj se u proračunu nadomješta subtranzijentnom reaktancijom i radnim otporom spojenom između čvora na koji je sinkroni stroj priključen i neutralne točke.

### 3.3 Synchronous machines

A synchronous machine is represented in the calculation by an equivalent circuit diagram with the subtransient reactance and active resistance connected between the node at which the synchronous machine is connected and a neutral point.



Slika 6 – Nadomjesna shema sinkronog stroja  
Figure 6 – Equivalent circuit diagram of a synchronous machine

Induktivni otpor sinkronog stroja na nazivnoj frekvenciji računa se pomoću formule:

The inductive resistance of a synchronous machine at rated frequency is calculated using the following formula:

$$X_d'' = \frac{x_d''}{100} \cdot \frac{U^2}{S_n} [\Omega], \quad (22)$$

gdje su:

$x_d''$  – relativna direktna subtranzijentna reaktancija [%],  
 $S_n$  – nazivna snaga sinkronog stroja [MVA],  
 $U$  – referentni napon [kV].

where:

$x_d''$  – relative direct subtransient reactance [%],  
 $S_n$  – rated power of the synchronous machine [MVA],  
 $U$  – reference voltage [kV].

S porastom frekvencije induktivni otpor se mijenja prema formuli:

With increasing frequency, inductive resistance varies according to the formula:

$$X_{d,h}'' = h \cdot X_d'' = h \cdot \frac{x_d''}{100} \cdot \frac{U^2}{S_n} [\Omega], \quad (23)$$

gdje je:

$h$  – omjer promatrane i nazivne frekvencije.

Radni otpor u ovisnosti o frekvenciji mijenja se prema formuli [3]:

where:

$h$  – the ratio of the observed and the rated frequency.

Active resistance as a function of frequency varies according to the formula [3]:

$$R_h = R \cdot (1 + 0,1 \cdot h^{1,5}) [\Omega]. \quad (24)$$

Za generatore s istaknutim polovima za inverznu reaktanciju vrijedi:

For salient pole generators, the inverse reactance is:

$$X_i'' = \frac{1}{2} (X_d'' + X_q'') [\Omega], \quad (25)$$

gdje je:

$X_q''$  – subtranzijentna poprečna reaktancija sinkronog stroja [ $\Omega$ ].

where:

$X_q''$  – subtransient transversal reactance of the synchronous machine [ $\Omega$ ].

Impedancija u direktnom sustavu na promatranoj frekvenciji iznosi:

Impedance in the direct system at the observed frequency is as follows

$$Z_{d,h} = Z_{0,h} = R_h + jX_{d,h}'' [\Omega]. \quad (26)$$

Impedancija u inverznom sustavu na promatranoj frekvenciji iznosi:

Impedance in the inverse system at the observed frequency is as follows:

$$Z_{i,h} = R_h + jX_{i,h}'' [\Omega]. \quad (27)$$

### 3.4 Asinkroni strojevi

Asinkroni stroj se, kao i sinkroni, u proračunu nadomješta reaktancijom i radnim otporom spojenom između čvora na koji je asinkroni stroj priključen i neutralne točke (slika 3).

Impedancija asinkronog stroja na nazivnoj frekvenciji određuje se pomoću formule:

### 3.4 Asynchronous machines

An asynchronous machine, like synchronous machines, is represented in the calculation by an equivalent circuit diagram with the subtransient reactance and active resistance connected between the node at which the asynchronous machine is connected and a neutral point. (Figure 3).

Impedance of the asynchronous machine at rated frequency is determined using the following formula:

$$Z = \frac{U}{\sqrt{3} \cdot I_{ks}} = \frac{I_n}{I_{ks}} \cdot \frac{U^2}{S_n} [\Omega], \quad (28)$$

gdje su:

$S_n$  – nazivna snaga asinkronog stroja [MVA],  
 $U$  – referentni napon [kV],  
 $I_{ks}$  – struja pokusa kratkog spoja asinkronog stroja [kA],  
 $I_n$  – nazivna struja asinkronog stroja [kA].

S porastom frekvencije impedancija asinkronog stroja se mijenja prema formuli:

where:

$S_n$  – rated power of the asynchronous machine [MVA],  
 $U$  – reference voltage [kV],  
 $I_{ks}$  – test short circuit current of the asynchronous machine [kA],  
 $I_n$  – rated current of the asynchronous machine [kA].

With increasing frequency, the impedance of the synchronous machine varies according to the formula:

$$Z_{d,h} = \sqrt{h} \cdot R + j(h \cdot X) [\Omega], \quad (29)$$

gdje su:

$R$  – radni otpor [ $\Omega$ ],  
 $X$  – jalovi induktivni otpor [ $\Omega$ ],  
 $h$  – omjer promatrane i nazivne frekvencije.

where:

$R$  – active resistance [ $\Omega$ ],  
 $X$  – reactive resistance [ $\Omega$ ],  
 $h$  – the ratio of the observed and the rated frequency.



### 3.5 Modeliranje opterećenja

Model opterećenja ima vrlo velik utjecaj na točnost proračuna harmonika. Zbog toga što se u proračunu u nadomjesnoj shemi mreže javlja kao poprečni element, jako utječe na iznos Theveninove impedancije pa tako i na iznos izračunatog MTU signala. Iznos impedancije, kojim se opterećenje modelira opada s porastom opterećenja mreže.

U literaturi postoji nekoliko predloženih frekvencijski ovisnih modela tereta. Nadomjesne sheme tereta mogu predstavljati pojedinog potrošača ili grupu potrošača na sabirnicama. Postoje velike razlike u promjeni impedancije s frekvencijom kod industrijskih potrošača i kućanstava. Industrijski potrošači često imaju kondenzatorske baterije za kompenzaciju jalove snage, što može uzrokovati serijsku i paralelnu rezonanciju. Nekoliko je predloženih modela tereta koji su prikazani na slici 7, [5].

### 3.5 Load modeling

A load model has a very great impact on the accuracy of the harmonics calculation. Because in the calculation in an equivalent network circuit diagram occurs as a transversal element, and has a great impact on the value of the Thevenin impedance and thus on the value of the calculated ripple control signal. The impedance value used to model the load decreases with increasing network load.

In the literature, there are several proposed frequency-dependent load models. An equivalent load diagram can represent an individual load (consumer) or a load group (group of consumers) connected to busbars. There are great differences in impedance variation as a function of frequency for industrial customers and households. Industrial customers frequently have capacitor banks to compensate for the reactive power, which can cause serial and parallel resonances. Several proposed load models are presented in Figure 7.

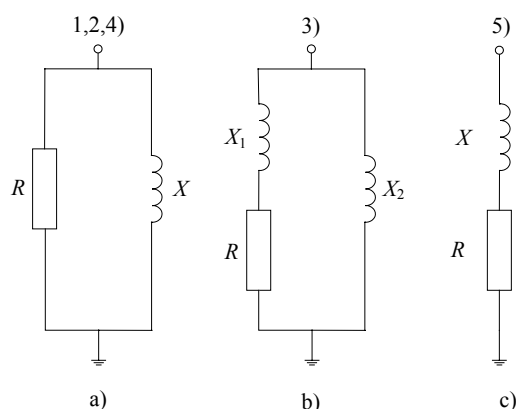

Slika 7 – Modeliranje tereta za proračun viših harmonika  
Figure 7 – Load modeling for the calculation of higher harmonics

Frekvencijski ovisne impedancije svakog od modela određuju se na sljedeći način:

A) U prvom modelu reaktancija i otpor ovisni su o frekvenciji (slika 7a):

The frequency dependent impedances of each of the models are determined in the following manner:

A) In the first model, reactance and resistance are frequency dependant (Figure 7a):

$$X_h = \frac{U^2}{k_h \cdot Q} [\Omega], \quad (30)$$

$$R_h = \frac{U^2}{k_h \cdot P} [\Omega], \quad (31)$$

$$k_h = 0,1 \cdot h + 0,9 \quad (32)$$

gdje su:

$h$  – omjer promatrane i nazivne frekvencije,  
 $U$  – referentni napon [kV],  
 $P$  – djelatna snaga na nazivnoj frekvenciji [MW],  
 $Q$  – jalova snaga na nazivnoj frekvenciji [Mvar].

where:

$h$  – the ratio of the observed and the rated frequency,  
 $U$  – reference voltage [kV],  
 $P$  – active power at the rated frequency [MW],  
 $Q$  – reactive power at the rated frequency [Mvar].

---

$$Y_{d,h} = \frac{1}{R_h} - j\left(\frac{1}{X_h}\right) [\text{S}]. \quad (33)$$

---

B) U drugom modelu reaktancija je frekvencijski ovisna, dok je paralelni otpor konstantan (slika 7a):

B) In the second model, reactance is frequency dependant, while the parallel resistance is constant (Figure 7a):

$$X_h = \frac{h \cdot U^2}{Q} [\Omega], \quad (34)$$

$$R = \frac{U^2}{P} [\Omega], \quad (35)$$

$$Y_{d,h} = \frac{1}{R} - j\left(\frac{1}{X_h}\right) [\text{S}]. \quad (36)$$

---

C) Treći model, koji se još naziva i CIGRÉ-in model, dobiven je mjerenjem tereta na srednjem naponu korištenjem tonfrekvencijskog generatora signala na frekvencijama 175 i 495 Hz (slika 7b):

C) The third model, which is also known as the CIGRÉ model, is obtained by measuring the medium voltage load using a tone frequency generator at frequencies of 175 and 495 Hz (Figure 7b):

$$R = \frac{U^2}{P} [\Omega], \quad (37)$$

$$X_{1,h} = 0,073 \cdot h \cdot R [\Omega], \quad (38)$$

$$X_{2,h} = \frac{h \cdot R}{6,7 \cdot \frac{Q}{P} - 0,74} [\Omega], \quad (39)$$

$$Y_{d,h} = \frac{1}{R + jX_{1,h}} - j\left(\frac{1}{X_{2,h}}\right) [\text{S}]. \quad (40)$$

---

D) Kod četvrtog modela impedancija je neovisna o frekvenciji i jednaka je impedanciji na osnovnoj frekvenciji (slika 7a):

D) In the fourth model, impedance is independent of frequency and equal to the impedance at the basic frequency (Figure 7a):

$$X_h = \frac{U^2}{Q} [\Omega], \quad (41)$$

$$R = \frac{U^2}{P} [\Omega], \quad (42)$$

$$Y_{d,h} = Y_{1,h} = Y_{0,h} = \frac{1}{R} - j \left( \frac{1}{X_h} \right) [S]. \quad (43)$$

E) Peti model je serijska kombinacija induktiviteta ovisnog o frekvenciji i otpora koji je neovisan o frekvenciji (slika 7c):

E) The fifth model is a serial combination of inductance, which is frequency dependent, and resistance, which is independent of frequency (Figure 7c):

$$X_h = h \cdot \frac{U^2}{S} \cdot \sin \varphi [\Omega], \quad (44)$$

$$R = \frac{U^2}{S} \cdot \cos \varphi [\Omega], \quad (45)$$

gdje su:

$S$  – prividna snaga opterećenja [MVA],  
 $\cos \varphi$  – faktor snage opterećenja.

where:

$S$  – apparent power load [MVA],  
 $\cos \varphi$  – power load factor.

$$Z_{d,h} = R + jX_h [\Omega]. \quad (46)$$

### 3.6 Kondenzatorske baterije

Kondenzatorska baterija prikazuje se susceptancijom spojenom između čvora u kojeg je spojena i referentne neutralne točke. U pojedinim izvedbama za zaštitu baterije, ispred kondenzatora se spaja prigušnica tako da nadomjesna shema izgleda kao i za uskopojasni filter (slika 11). Izraz za impedanciju kondenzatorske baterije glasi:

### 3.6 Capacitor banks

A capacitor bank is represented with the susceptance connected between the node to which it is connected and a reference neutral point. In some cases, an inductor is connected in front of a capacitor bank to protect it. In that case, the equivalent circuit diagram looks like the one for a narrow-band filter (Figure 11). The expression for the impedance of a capacitor bank is as follows:

$$Z_{d,h} = R + j(h \cdot X) - jB_h [\Omega], \quad (47)$$

gdje su:

$h$  – omjer promatrane i nazivne frekvencije,  
 $B_h$  – susceptancija kondenzatorske baterije u ovisnosti o frekvenciji [S],  
 $R$  – djelatni otpor prigušnice [ $\Omega$ ],  
 $X$  – jalovi otpor prigušnice [ $\Omega$ ].

where:

$h$  – the ratio of the observed and the rated frequency,  
 $B_h$  – susceptance of the capacitor bank as a function of frequency [S],  
 $R$  – active resistance of the inductor [ $\Omega$ ],  
 $X$  – reactive resistance of the inductor [ $\Omega$ ].

U slučaju spoja u zvijezdu, susceptancija kondenzatorske baterije određuje se iz njezine nazivne reaktivne snage, na temelju formule:

$$B = \frac{Q}{U^2} [\text{S}]. \quad (48)$$

In the case of a star connection, susceptance of a capacitor bank is determined from its rated reactive power, on the basis of the following formula:

U slučaju spoja u trokut susceptancija kondenzatorske baterije određuje se iz njezine nazivne reaktivne snage na temelju formule:

$$B = \frac{Q}{3 \cdot U^2} [\Omega], \quad (49)$$

In the case of a delta connection, the susceptance of a capacitor bank is determined from its rated reactive power on the basis of the following formula:

gdje su:

$Q$  – nazivna reaktivna snaga kondenzatorske baterije [Mvar],  
 $U$  – referentni napon [kV].

where:

$Q$  – rated reactive power of a capacitor bank [Mvar],  
 $U$  – reference voltage [kV].

Ovisnost o frekvenciji određuje se na temelju formule:

The frequency dependence of the susceptance is determined according to the following formula:

$$B_h = h \cdot B [\text{S}]. \quad (50)$$

### 3.7 Dvonamotni transformatori

Dvonamotni transformator se u ekvivalentnim shemama direktnog i inverznog sustava može prikazati na sljedeći način:

### 3.7 Two winding transformers

The equivalent circuit of a two winding transformer for the direct and inverse system can be represented in the following manner:

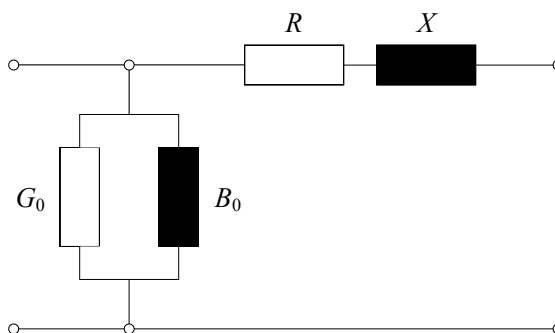

Slika 8 – Ekvivalentna shema dvonamotnog transformatora  
 Figure 8 – Equivalent circuit diagram of a two winding transformer

Uzdužnu impedanciju transformatora na nazivnoj frekvenciji  $Z = R + jX$  može se izračunati iz podataka transformatora, na sljedeći način:

The longitudinal impedance of a transformer at the rated frequency  $Z = R + jX$  can be calculated from the transformer data, in the following manner:

$$Z = \frac{u_k}{100} \cdot \frac{U^2}{S_n} [\Omega], \quad (51)$$

gdje su:

$u_k$  – napon pokusa kratkog spoja [%],  
 $U$  – referentni napon [kV],  
 $S_n$  – nazivna snaga [MVA].

Djelatna komponenta uzdužne grane transformatora računa se iz podataka o gubicima kratkog spoja:

where:

$u_k$  – short circuit voltage [%],  
 $U$  – reference voltage [kV],  
 $S_n$  – rated power [MVA].

The active component of the longitudinal transformer branch is calculated from data obtained from a short circuit test:

---

$$R = \frac{U^2}{S_n^2} \cdot P_{cu} \text{ [\Omega]}, \quad (52)$$

---

gdje su:

$P_{cu}$  – gubici u bakru [MW].

Nakon što je određena apsolutna vrijednost i realna komponenta impedancije transformatora, može se odrediti i reaktancija  $X$  pomoću formule:

where:

$P_{cu}$  – copper losses [MW].

After the absolute value and real components of the transformer impedance are determined, it is also possible to determine reactance  $X$  using the following formula:

---

$$X = \sqrt{Z^2 - R^2} \text{ [\Omega]}. \quad (53)$$

---

Apsolutna vrijednost admitancije poprečne grane računa se iz podatka o struji praznog hoda:

The absolute value of the admittance of the transversal branch is calculated according to data from the no-load test:

---

$$Y_0 = \frac{S_n}{U^2} \cdot \frac{i_0}{100} \text{ [S]}, \quad (54)$$

---

gdje je:

$i_0$  – struja praznog hoda [%].

Djelatna komponenta poprečne grane proizlazi iz podataka o gubicima praznog hoda:

where:

$i_0$  – no-load current [%].

The active component of the transversal branch results from the no-load losses:

---

$$G_0 = \frac{P_{Fe}}{U^2} \text{ [S]}, \quad (55)$$

---

gdje su:

$P_{Fe}$  – gubici u željezu [MW].

Susceptancija se može odrediti iz relacije:

where:

$P_{Fe}$  – iron losses [MW].

Susceptance can be determined from the following expression:

---

$$B_0 = \sqrt{Y_0^2 - G_0^2} \text{ [\Omega]}. \quad (56)$$

---



Umjesto s  $\Gamma$ -shemom moguće je koristiti  $\pi$ -shemu. Razlika je jedino u tome što će poprečna grana biti podijeljena na dvije poprečne grane.

U poprečnoj grani vrijednosti impedancije daleko su veće nego u uzdužnoj grani pa se stoga mogu zanemariti, što uz praktički nesmanjenu točnost, omogućava formiranje jednostavnije ekvivalentne sheme.

Unutarnja rezonantna frekvencija transformatora javlja se daleko iznad frekvencijskog dosega promatranja. Kapacitivnost među namotima i kapacitivnost prema zemlji imaju vrlo mali utjecaj na točnost rezultata.

Radni otpor transformatora na promatranoj frekvenciji određuje se po formuli [4]:

$$R_h = R \cdot (1 + k \cdot h^x) [\Omega], \quad (57)$$

gdje su:

- $k$  – faktor koji se kreće od 0,1 do 0,2 kod srednjo naponskih i visokonaponskih transformatora,
- $x$  – eksponent koji se kreće od 1,2 do 1,5 ovisno o snazi transformatora,
- $h$  – omjer promatrane i nazivne frekvencije napona.

Uzdužna reaktancija transformatora na promatranoj frekvenciji određuje se po formuli:

$$X_h = h \cdot X [\Omega]. \quad (58)$$

Susceptancija poprečne grane na promatranoj frekvenciji određuje se po formuli:

$$B_{0,h} = \frac{B_0}{h} [\Omega]. \quad (59)$$

Izraz za uzdužnu impedanciju transformatora u direktnom i inverznom sustavu na promatranoj frekvenciji glasi:

$$Z_{d,h} = R_h + jX_h [\Omega]. \quad (60)$$

Instead of a  $\Gamma$ -diagram, it is possible to use a  $\pi$ -diagram. The only difference is that the transversal branch will be divided into two transversal branches.

In a transversal branch, the impedance values are far greater than in the longitudinal branch and therefore can be ignored, which practically permits the formation of a simpler equivalent circuit diagram with the same accuracy.

Transformer internal resonant frequency occurs far above the frequency range observed. Capacitance between the windings and capacitance to ground have very little impact on the precision of the results.

Active transformer resistance at the observed frequency is determined according to the following formula [4]:

where:

- $k$  – factor ranging from 0,1 to 0,2 for medium voltage and high voltage transformers
- $x$  – exponent ranging from 1,2 to 1,5, depending on the power rating of the transformer,
- $h$  – the ratio of the observed and rated frequency of the voltage.

Longitudinal transformer reactance at the observed frequency is determined according to the following formula:

The susceptance of the transversal branch at the observed frequency is determined according to the following formula:

The expression for the longitudinal impedance of a transformer in direct and inverse systems at the observed frequency is as follows:

Izraz za admitanciju poprečne grane transformatora u direktnom i inverznom sustavu na promatranoj frekvenciji glasi:

$$Y_{d,h} = G_{0,h} + jB_{0,h} \text{ [S]}. \quad (61)$$

The expression for transversal branch admittance in direct and inverse systems at the observed frequency is as follows:

Načelo modeliranja dvonamotnog transformatora s nenazivnim prijenosnim omjerom prikazano je na sljedećoj slici (slika 9).

The principle for the modeling of a two winding transformer with a non-rated turns ratio is presented in the following figure (Figure 9).

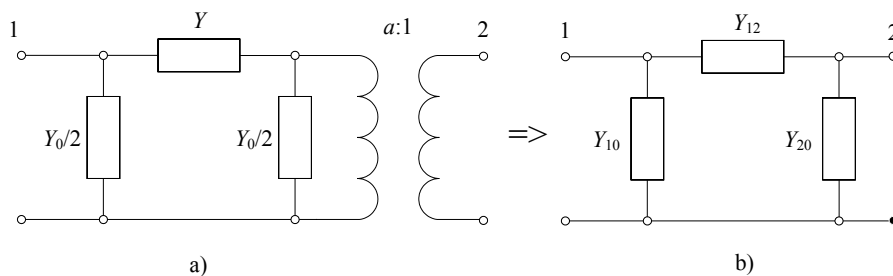

**Slika 9** – Shema dvonamotnog transformatora za nenazivni prijenosni omjer  
**Figure 9** – Circuit diagram of a two winding transformer with a non-rated turns ratio

$$Y_{12} = \frac{Y}{a} \text{ [S]}, \quad (62)$$

$$Y_{10} = \frac{1-a}{a^2} \cdot Y + \frac{Y_0}{2 \cdot a^2} \text{ [S]}, \quad (63)$$

$$Y_{20} = \frac{a-1}{a} \cdot Y + \frac{Y_0}{2} \text{ [S]}, \quad (64)$$

$$a = \frac{U_{1s}}{U_{2s}} \cdot \frac{U_{1n}}{U_{2n}}, \quad (65)$$

gdje su :

where:

$U_{1s}$ ,  $U_{2s}$  – stvarni naponi primara i sekundara [kV],

$U_{1s}$ ,  $U_{2s}$  – the actual primary and secondary voltages [kV],

$U_{1n}$ ,  $U_{2n}$  – nazivni naponi primara i sekundara [kV].

$U_{1n}$ ,  $U_{2n}$  – rated primary and secondary voltages [kV].

### 3.8 Tronamotni transformatori

Nadomjesna shema tronamotnog transformatora u direktnom i inverznom sustavu simetričnih komponenta određuje se prema slici 10.

### 3.8 Three winding transformers

The equivalent circuit diagram of a three winding transformer in direct and inverse systems of symmetrical components is determined according to Figure 10.

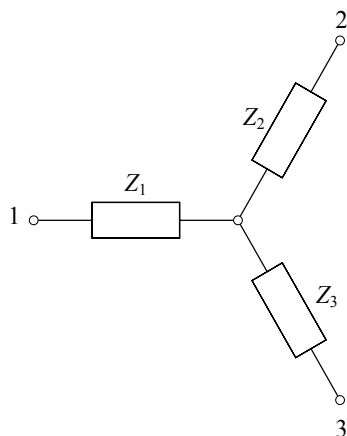

Slika 8 – Ekvivalentna shema dvonamotnog transformatora  
Figure 8 – Equivalent circuit diagram of a two winding transformer

Kada nazivne snage pojedinih namota tronamotnog transformatora nisu međusobno jednake, treba u računu uzeti prolaznu snagu, ako nije drugačije napomenuto uz podatke o transformatoru. Prolazna snaga je nazivna snaga slabijeg od dva promatrana namota. Tako je:

When the power ratings of the individual windings of a three winding transformer are not equal, in the calculation it is necessary to take the transient power rating into account, if not otherwise specified in the transformer data. The transient power rating is the rated power of the weaker of the two passing windings. Thus:

$$Z_{12} = \frac{u_{k12}}{100} \cdot \frac{U^2}{S_{n12}} [\Omega], \quad (66)$$

$$Z_{13} = \frac{u_{k13}}{100} \cdot \frac{U^2}{S_{n13}} [\Omega], \quad (67)$$

$$Z_{23} = \frac{u_{k23}}{100} \cdot \frac{U^2}{S_{n23}} [\Omega], \quad (68)$$

gdje su:

$u_{k12}, u_{k13}, u_{k23}$  – naponi kratkog spoja [%],  
 $S_{n12}, S_{n13}, S_{n23}$  – prolazne snage slabijeg od dva prolazna namota [MVA],  
 $U$  – referentni napon [kV].

Izrazi za impedancije iz nadomjesne sheme glase:

where:

$u_{k12}, u_{k13}, u_{k23}$  – short circuit voltages [%],  
 $S_{n12}, S_{n13}, S_{n23}$  – transient power ratings of the weaker of the two passing windings MVA,  
 $U$  – reference voltage [kV].

The expressions for impedances from the equivalent circuit diagram are as follows:

$$Z_1 = \frac{1}{2}(Z_{12} + Z_{13} - Z_{23})[\Omega], \quad (69)$$

$$Z_2 = \frac{1}{2}(Z_{12} + Z_{23} - Z_{13})[\Omega], \quad (70)$$

$$Z_3 = \frac{1}{2}(Z_{13} + Z_{23} - Z_{12})[\Omega]. \quad (71)$$

Za ekvivalentnu shemu tronamotnog transformatora može se pri proračunu koristiti i spoj u trokutu umjesto zvijezde. Impedancije spoja u trokutu tada treba transfiguracijom izračunati iz impedancija spoja u zvijezdu.

Ekvivalentne sheme autotransformatora s tercijarom jednake su onima običnih transformatora, a parametri se određuju na isti način.

### 3.9 Prigušnice

Prigušnice su također česti elementi mreža, a postavljaju se sa svrhom da smanje struje kratkog spoja. Uglavnom se postavljaju i ispred kondenzatorskih baterija, bilo sa svrhom formiranja filtra za određene harmonike ili pak samo za ograničavanje struja uklapanja baterija na mrežu. Ekvivalentna shema ista je kao i kod dvonamotog transformatora uz zanemarenje poprečnih admitancija. S obzirom da djelatni otpor prigušnice iznosi do 3 % veličine reaktancije prigušnice vrijedi sljedeća relacija:

$$Z \approx X = \frac{u_n}{100 \%} \cdot \frac{U}{\sqrt{3} \cdot I_n} = \frac{u_n}{100 \%} \cdot \frac{U^2}{Q_n} \quad [\Omega], \quad (72)$$

gdje su:

$u_n$  – jpad napona pri nazivnoj struji [%],  
 $I_n$  – jnazivna struja [A],  
 $Q_n$  – jnazivna jalova snaga [Mvar],  
 $U$  – jreferentni napon [kV].

Reaktancija se mijenja s frekvencijom prema formuli:

$$X_h = h \cdot X \quad [\Omega], \quad (72)$$

gdje je:

$h$  – omjer promatrane i nazivne frekvencije.

### 3.10 Uskopojasni filter

Uskopojasni filter nadomješta se serijskim RLC spojem, koji je spojen između čvora gdje je priključen i neutralne referentne točke (slika 11):

For the equivalent circuit diagram of a three winding transformer, it is also possible to use the delta connection instead of the star connection in the calculation. The impedance of the delta connection should be calculated by transfiguration from the impedance of the star connection.

The equivalent circuit diagrams of an autotransformer with tertiary winding are identical to those of ordinary transformers, and the parameters are determined in the same manner:

### 3.9 Inductors

Inductors are also common network elements and are installed for the purpose of reducing short circuit currents. They are generally installed in front of capacitor banks, either as a filter for certain harmonics or merely to reduce a capacitor bank inrush current when it is connected to the network. The equivalent circuit diagram is the same as for a two winding transformer and when the transversal admittance is neglected. Since the resistance of an inductor is up to 3 % of the order of magnitude of the inductor's reactance, the following expression applies:

where:

$u_n$  – the voltage drop at the rated current [%],  
 $I_n$  – rated current [A],  
 $Q_n$  – rated reactive power [Mvar],  
 $U$  – reference voltage [kV].

Reactance varies with frequency, according to the following formula:

where:

$h$  – the ratio of the observed and the rated frequency.

### 3.10 Narrow-band filter

A narrow-band filter is represented with a series RLC branch connected between the node to which it is connected and the neutral reference point (Figure 11):

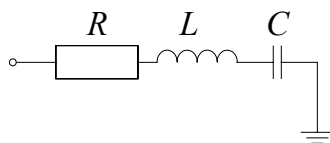

Slika 11 – Uskopojasni filtar  
Figure 11 – Narrow-band filter

Izraz za impedanciju uskopojasnog filtra glasi:

The expression for narrow-band filter impedance is as follows:

$$Z_h = R + j \left( h \cdot \omega \cdot L - \frac{1}{h \cdot \omega \cdot C} \right) [\Omega], \quad [74]$$

gdje su:

$R$  – djelatni otpor prigušnice [ $\Omega$ ],  
 $L$  – induktivitet prigušnice [H],  
 $C$  – kapacitet kondenzatora [F],  
 $\omega$  – kružna frekvencija [rad/s],  
 $h$  – omjer promatrane i nazivne frekvencije.

where:

$R$  – active resistance of the inductor [ $\Omega$ ],  
 $L$  – inductivity of the inductor [H],  
 $C$  – capacitor conductivity [F],  
 $\omega$  – angular frequency [rad/s],  
 $h$  – the ratio of the observed and rated frequency.

### 3.11 Modeliranje razdjelne mreže

Pri proračunu širenja MTU signala u mreži 110 kV, 35(30) kV, ili 10(20) kV, često je potrebno modelom nadomjestiti razdjelnu mrežu niže naponske razine, koja je priključena na promatranu mrežu. To se radi iz praktičnih razloga, jer je često nemoguće pribaviti podatke o svim komponentama razdjelne mreže niže naponske razine. Tako se zapravo razdjelna mreža nadomješta modelom, koji sadrži prevladavajuće značajke promatrane mreže. U nadomjesnom modelu razdjelne mreže potrebno je uvažiti sljedeće pretpostavke:

- nadzemni vodovi i kabeli modeliraju se ekvivalentnom  $\pi$ -shemom. Kratki se vodovi mogu nadomjestiti ukupnim kapacitetom voda, spojenim na krajnje sabirnice,
- transformatori između promatrane mreže i mreže niže naponske razine nadomještaju se modelom transformatora,
- kondenzatorske baterije za kompenzaciju jalove snage trebaju se modelirati čim točnije,
- komponente, kako što su zavojnice, filtri i generatori trebaju se modelirati čim točnije,
- modeliranje mreže mora biti čim detaljnije u blizini onih dijelova mreže, koji su od interesa. Pojednostavljeni ekvivalenti mreže mogu se koristiti samo za udaljene dijelove mreže.

U srednjonaponskoj mreži postoje kabelski vodovi i kompenzacija jalove snage, koje je

### 3.11 Distribution network modeling

In the calculation of the propagation of the ripple control signal in a 110 kV, 35(30) kV or 10(20) kV network, it is often necessary to make an equivalent model of the low voltage distribution network, which is connected to the observed network. This is done for practical reasons because it is frequently impossible to obtain data on all the components of a distribution network of a low voltage level. Thus, the distribution model is replaced by a model, which contains the predominant characteristics of the observed network. In the equivalent model of a distribution network, it is necessary to take the following assumptions into account:

- overhead lines and cables are modeled with an equivalent  $\pi$ -diagram. Short lines can be replaced by the total capacitance of the line, connected to the end busbars,
- transformers between the observed network and the lower voltage network are represented by an equivalent transformer model,
- capacitor banks for the compensation of reactive power should be modeled as precisely as possible,
- components such as inductors, filters and generators should be modeled as precisely as possible,
- network modeling must be as detailed as possible in the vicinity of those parts of the network that are of interest. Simplified network equivalents can only be used for distant parts of the network.

In a medium voltage network, there are cable lines and reactive power compensators which must be



potrebno uzeti u obzir pri proračunu harmonika. Kapaciteti će se u modelu prikazati kao jedan kapacitet paralelno spojen s modelom opterećenja (slika 12). Spomenuti kapacitet može se u ovisnosti o tipu mreže određivati iz jalove reaktivne snage, koja se određuje iz udjela u ukupnom radnom opterećenju.

taken into account in the calculation of harmonics. Capacitances will be presented in the model as one capacitance connected in parallel with the model of the load. (Figure 12). This capacitance, depending on the type of network, can be determined from the reactive power, which is determined from its share of the total active load.

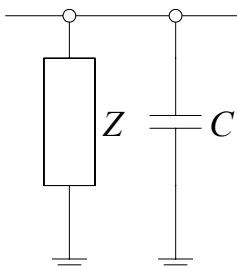

Slika 12 – Model opterećenja s kapacitetom  
Figure 12 – A load model with capacitance

### 3.12 Nadomjesna shema aktivne mreže

U ekvivalentnim shemama aktivna mreža prikazuje se odgovarajućom impedancijom:

### 3.12 The equivalent diagram of an active network

In the equivalent circuit diagrams, an active network is presented by the corresponding impedance:

$$Z_{d,h} = R + j(h \cdot X) [\Omega], \quad (75)$$

gdje su:

$R$  – radni otpor mreže  $[\Omega]$ ,  
 $X$  – reaktancija mreže  $[\Omega]$ ,  
 $h$  – omjer promatrane i nazivne frekvencije.

Reaktancija mreže u direktnom, inverznom i nul-tom sustavu računa se iz podataka o početnoj trofaznoj i jednofaznoj struji kratkog spoja mreže u točki nadomještanja:

where:

$R$  – active network resistance  $[\Omega]$ ,  
 $X$  – network reactance  $[\Omega]$ ,  
 $h$  – the ratio of the observed and the rated frequency.

Network reactance in the direct, inverse and zero system is calculated from the data of the three phase and single phase short circuit currents at the equivalent node:

$$Z_d = Z_i = \frac{U}{\sqrt{3} \cdot I_{KS3}} [\Omega], \quad (76)$$

$$Z_0 = \sqrt{3} \frac{U}{I_{KS1}} - \frac{2}{\sqrt{3}} \cdot \frac{U}{I_{KS3}} [\Omega], \quad (77)$$

gdje su:

$I_{KS3}$  – struja trofaznog kratkog spoja u točki nadomještanja [kA],  
 $I_{KS1}$  – struja jednofaznog kratkog spoja u točki ekvivalentiranja [kA],  
 $U$  – referentni napon [kV].

where:

$I_{KS3}$  – three phase short circuit current at the equivalent node [MVA],  
 $I_{KS1}$  – single phase short circuit current at the equivalent node [MVA],  
 $U$  – reference voltage [kV].

Kod naponskih razina viših od 35 kV djelatni otpor se može zanemariti. U ostalim slučajevima djelatni otpor može se odrediti iz omjera  $R/X$  aktivne mreže:

$$X = \frac{Z}{\sqrt{\left(\frac{R}{X}\right)^2 + 1}} [\Omega], \quad (78)$$

$$R = \sqrt{Z^2 - X^2} [\Omega]. \quad (79)$$

## 4 USPOREDBA REZULTATA PRORAČUNA I MJERENJA

Kako bi se predloženi model proračuna širenja MTU signala mogao verificirati potrebno je usporediti rezultate proračuna i izmjerene veličine razine MTU signala u mrežama gdje postoji utiskivanje MTU na 110 kV.

U Hrvatskoj elektroprivredi (HEP-u) do sada su izgrađena dva postrojenja MTU na 110 kV. Prvo postrojenje, koje je pušteno u pogon je u DP Elektrodalmacija Split u TS 110/35 kV Vrboran. Krajem 2004. godine također je i u DP Elektra Zagreb pušteno u pogon MTU postrojenje u TS 110/20 kV Botinec.

Mjerenja razine MTU signala napravljena su na području DP Elektrodalmacija Split za potrebe studije [7] i na području DP Elektra Zagreb za potrebe studije [8].

U ovom članku napravljeni su proračuni širenja MTU signala s odgovarajućim parametrima MTU utiskivačkog postrojenja. Rezultati proračuna usporedit će se s rezultatima navedenih mjerenja.

### 4.1 DP Elektro-Dalmacija Split

Za područje DP Elektrodalmacija Split napravljeni su proračuni za sadašnje stanje mreže i opterećenja (2005. godina). Osnovni parametri s kojima se napravio proračun su:

$$\begin{aligned} f_{\text{MTU}} &= 208,33 \text{ Hz}, \\ u_{\text{MTU}} &= 2,9 \%, \\ I_{\text{MTU}} &= 104,5 \text{ A}, \\ S_{\text{MTU}} &= 577,5 \text{ kVA}, \\ Z_{\text{mreže}} &= 17,6 \Omega. \end{aligned}$$

In voltage levels higher than 35 kV, active resistance can be ignored. In other cases, active resistance can be determined from the ratio  $R/X$  of the active network:

## 4 COMPARISON OF THE CALCULATION AND MEASUREMENT RESULTS

In order to verify the proposed calculation model of the propagation of the ripple control signal, it is necessary to compare the results of the calculations and the measured values of the level of ripple control signals in the 110 kV networks.

In the Croatian Electric Power Company (HEP), two 110 kV ripple control plants have been built up to the present. The first plant was put into operation in the area of DP Elektrodalmacija Split in the 110/35 kV Vrboran Substation. In late 2004, a ripple control plant in the 110/20 kV Botinec Substation was put into operation.

Measurements of the ripple control signal level were performed in the area of DP Elektrodalmacija Split for the purposes of the study [7] and the area of DP Elektra Zagreb for the purposes of the study [8].

In this article, calculations were performed for the propagation of the ripple control signal with the corresponding parameters of the ripple control injection plant. The results of the calculations will be compared with the results of the cited measurements.

### 4.1 Area of DP Elektro-Dalmacija Split

For the area of DP Elektrodalmacija Split, calculations were performed for the state of the network and network load in the year 2005. The basic parameters used in the calculation are as follows:

$$\begin{aligned} f_{\text{MTU}} &= 208,33 \text{ Hz}, \\ u_{\text{MTU}} &= 2,9 \%, \\ I_{\text{MTU}} &= 104,5 \text{ A}, \\ S_{\text{MTU}} &= 577,5 \text{ kVA}, \\ Z_{\text{mreže}} &= 17,6 \Omega. \end{aligned}$$

U tablici 1 navedeni su usporedno rezultati proračuna i rezultati mjerenja razine MTU signala u čvorovima mreže.

In Table 1, a comparison of the calculation results and the measurement results of the ripple control signal in the network nodes is presented.

Tablica 1 – Usporedba rezultata proračuna i izmjerenih veličina MTU signala u mreži DP Elektrodalmacija Split [7]  
Table 1 – Comparison of the results of the calculated and measured values of the ripple control signals in the network area of DP Elektrodalmacija Split [7]

Naziv čvora / Name of node	uMTU % Izračunato / Calculated	uMTU % Izmjereno / Measured
Vrboran, 110 kV	2,90	2,90
Sučidar, 110 kV	2,90	2,80
Meterize, 110 kV	2,80	2,90
Konjsko, 110 kV	2,30	2,30
Stari Grad, 110 kv	2,30	2,70
Nerežišća, 110 kV	2,30	2,57
Dugi Rat, 110 kV	2,30	2,70
Zakučac, 110 kV	2,20	2,70
Makarska, 110 kV	1,90	1,94
Metriže, 35 kV	2,60	2,57
Zakučac, 35 kV	2,10	2,70
Stari Grad, 35 kV	2,10	3,89
Nerežišće, 35 kV	1,90	2,45
Makarska, 35 kV	1,70	1,76
Opuzen, 35 kV	1,30	1,59
Sučidar, 10 kV	2,10	2,31
Makarska, 10 kV	1,70	1,60

Iz tablice 1 vide se dobra slaganja izmjerenih i izračunatih rezultata.

From Table 1, it is evident that the measured and calculated results are in good agreement.

#### 4.2 Utjecaj kompenzacije u TS 110/10 kV Sopot

U TS 110/10 kV Sopot istražio se utjecaj kompenzacije na 10 kV. Radi toga su napravljena mjerenja i izvršeni usporedni proračuni koji su prikazani u tablici 2. Značajke kompenzacije su:

$$\begin{aligned} U &= 10 \text{ kV,} \\ Q &= 2,4 \text{ Mvar,} \\ L &= 5,9 \text{ mH.} \end{aligned}$$

Na temelju podataka može se izračunati da je kapacitet kondenzatorske baterije:

#### 4.2 Influence of compensation in the Sopot 110/10 kV Substation

In the Sopot 110/10 kV Substation, the influence of compensation on 10 kV was investigated. For this purpose, the measurements were conducted and calculations were performed that are presented in Table 2. The properties of compensation are as follows:

$$\begin{aligned} U &= 10 \text{ kV,} \\ Q &= 2,4 \text{ Mvar,} \\ L &= 5,9 \text{ mH.} \end{aligned}$$

On the basis of the data, it is possible to calculate the capacitance of the capacitor bank as follows:

$$C = \frac{Q}{U^2 \cdot 2 \cdot \pi \cdot f_n} = \frac{2,4}{10^2 \cdot 314} = 76,4 \text{ } \mu\text{F.} \quad (80)$$

Rezonantna frekvencije filterskog sklopa je:

The resonance frequency of the filter unit is as follows:

$$f_r = \frac{1}{2 \cdot \pi \sqrt{L \cdot C}} = \frac{1}{2 \cdot \pi \sqrt{5,9 \cdot 10^{-3} \cdot 76,4 \cdot 10^{-6}}} = 210 \text{ Hz.} \quad (80)$$

Iz navedenog se može zaključiti da će filter priključen na 10 kV sabirnice u TS 110/10 kV Sopot umanjiti signal na 10 kV sabirnicama, zbog toga što se rezonantna frekvencija nalazi dovoljno blizu frekvencije MTU signala (283,3 Hz). Spomenutu pretpostavku potvrdila su i mjerenja.

From the above, it can be concluded that the filter connected to the 10 kV busbar in the Sopot 110/10 kV Substation will reduce the signal at the 10kV busbar, because the resonant frequency is sufficiently close to the frequency of the ripple control signal (283,3 Hz). This hypothesis was also confirmed by measurements.

Tablica 2 – Utjecaj kompenzacije u TS 110/10 kV Sopot  
Table 2 – The effect of compensation at the Sopot 110/10 kV Substation

Kompenzacija / Compensation	uMTU % Izračunato / Calculated	uMTU % Izmjereno / Measured
uključena / on	1,63	1,78
isključena / off	2,21	2,18

Iz tablice 2 vide se dobra slaganja izmjerenih i izračunatih rezultata.

From Table 2, it is evident that the measured and calculated results are in good agreement.

## 5 ZAKLJUČAK

U posljednje vrijeme u Hrvatskoj elektroprivredi postoji tendencija ka ugradnji MTU utiskivačkih postrojenja na naponskoj razini 110 kV. Kako bi se došlo do optimalnih mjesta ugradnje i potrebnih značajki MTU utiskivačkih postrojenja, potrebno je prije ugradnje samog postrojenja za utiskivanje MTU signala, još u fazi planiranja čitavog sustava, napraviti proračune širenja MTU signala.

Za proračun širenja MTU signala potrebno je imati nadomjesnu shemu mreže koja uvažava frekvencijsku ovisnost realnih i imaginarnih dijelova impedancije pojedinih elemenata mreže, slično kao i kod proračuna širenja harmonika.

U ovom radu izložena je metoda proračuna širenja MTU signala na 110 kV razini. Temeljem izložene metode i frekvencijski ovisnog modela mreže napravljen je dodatni modul, kao dodatni programski paket NetHarmo v.5.0.

Usporedbom rezultata mjerenja razine MTU signala na području DP Elektroprivredna i DP Elektra Zagreb može se zaključiti da predložena metoda i programski paket mogu zadovoljiti

## 5 CONCLUSION

In recent times, at the Croatian Power Company (HEP), there has been a tendency to build ripple control plants at the voltage level of 110 kV. In order to determine the optimal installation site and the required characteristics of the ripple control plant prior to its construction, it is necessary to calculate the propagation of the ripple control signal during the planning of the entire system.

For the calculation of the propagation of the ripple control signal, it is necessary to have an equivalent circuit diagram of the network that takes into account the frequency dependence of the real and imaginary parts of the impedance of individual network elements, similar to the calculation of the propagation of harmonics.

In this article, a method is presented for the calculation of the propagation of the ripple control signal at the 110 kV level. Based upon the method presented and the frequency dependent network model, an additional module was devised as a supplement to the NetHarmo v.5.0 software package.

Through comparison of the results of the measurement of the levels of the ripple control signal

zahtjeve analize mreže u cilju iznalaženja optimalnog tehničkog rješenja ugradnje MTU utiskivačkog postrojenja.

in the area of DP Elektrodalmacija and DP Elektra Zagreb, it can be concluded that the proposed method and software package meet the requirements for the analysis of the network, with the goal of determining the optimal technical solution for the installation of ripple control plants.

---

## LITERATURA / REFERENCES

- [1] WAGMANN, L., MIHALEK, E., Izvodljivost primjene sustava mrežnog ton-frekventnog upravljanja sa utiskivanjem signala u mrežu 110 kV na području DP Elektroprimorje Rijeka, Energetski institut Hrvoje Požar, Zagreb, 2004.
- [2] ŽUTOBRADIĆ, S., WAGMANN, L., PUHARIĆ, M., Strategija uvođenja sustava mrežnog ton-frekventnog upravljanja (MTU) u mrežu 110 kV HEP-a, 6. simpozij o elektrodistribucijskoj djelatnosti, Osijek, 2006.
- [3] NEVEČEREL, D., MEHMEDOVIĆ, M., TONKOVIĆ, Z., WAGMANN, L., VARGOVIĆ, E., Nesimetrično opterećenje i viši harmonici u EES - I faza, Institut za elektroprivredu i energetiku, Zagreb, 1992.
- [4] FILIPOVIĆ, B., ŽUTOBRADIĆ, S., WAGMANN, L., Rješenje za suzbijanje širenja viših harmonika uzrokovanih postrojenjem ispravljačke stanice na Bliznečkoj cesti, Institut za elektroprivredu i energetiku, Zagreb, 1988.
- [5] Working Group 36-05 (Disturbing loads) (1), Harmonics, characteristic parameters, methods of study, estimates of existing values in the network, ELECTRA, Pariz, No. 77, 1981
- [6] MILUN, S., Kompenzacija jalove snage i utjecaj viših harmonika u elektrodistributivnoj mreži grada Zagreba, KNJIGA 2, Institut za elektroprivredu, Zagreb, 1988.
- [7] GOIĆ, R., MILUN, S., Razvoj i primjena sustava mrežnog ton-frekventnog upravljanja u DP Elektrodalmacija Split, Sveučilište u Splitu, Fakultet elektrotehnike, strojarstva i brodogradnje, Split, 2004.
- [8] BERBEROVIĆ, M., STRATEGIJA ZAMJENE I UVOĐENJA SUSTAVA MTU NA 110 KV U MREŽU HEP-A, Sveučilište u Zagrebu, Fakultet elektrotehnike i računarstva, Zagreb, 2006.

---

### Adrese autora:

Mr. sc. **Lahorko Wagmann**

lahorko.wagmann@hera.hr

Dr. sc. **Srđan Žutobradić**

szutobradic@hera.hr

Dr. sc. **Milan Puharić**

milan.puharic@hera.hr

Hrvatska energetska regulatorna agencija (HERA),  
Koturaška 51, 10000 Zagreb, Hrvatska

### Authors' addresses:

**Lahorko Wagmann**, MSc

lahorko.wagmann@hera.hr

**Srđan Žutobradić**, PhD

szutobradic@hera.hr

**Milan Puharić**, PhD

milan.puharic@hera.hr

Croatian Energy Regulatory Agency (CERA),  
Koturaška 51, 10000 Zagreb, Croatia

Uredništvo primilo rukopis:  
2007-10-09

Prihvaćeno:  
2008-01-16

Manuscript received on:  
2007-10-09

Accepted on:  
2008-01-16