

# Simple and Efficient Transcutaneous Inductive Micro-System Device Based on ASK Modulation at 6,78 MHz ISM Band

Mokhalad Khaleel ALGHRAIRI\*, Nasri Bin SULAIMAN, Roslina Bt Mohd SIDEK, Saad MUTASHAR

**Abstract:** This paper deals with designing a simple and efficient simultaneous inductive power and data transmission for transcutaneous Micro-system based on ASK modulation at 6,78 MHz industrial, scientific, and medical (ISM) band to avoid the tissue damage. The modified ASK modulator and inductive coupling link driven by efficient Class-E power amplifier with 94,5% efficiency and the coupling link of up to 78,29% of efficiency are introduced to transmit 500 Kbit/s of data with modulation index 12,5%, modulation rate 7,37%. The proposed design is simple, easy to implement and able to power the bio-implantable devices with DC V up to 5 V. The mathematical model is given and the system is designed and validated by professional OrCADPSPice 16,6 environment simulation using a standard AMS 0,35  $\mu\text{m}$  MOS technology. In addition, for real-time simulation, the electronic workbench MULISIM 11 has been used to simulate the class-E power amplifier switching. This design is useful for cochlear implants, retinal implants and implantable micro-system stimulator.

**Keywords:** biotelemetry systems; implanted devices; inductive coupling links; power amplifiers

## 1 INTRODUCTION

Nowadays, the inductive coupling links are widely used to power the bio-implantable devices such as implantable micro-system, cochlear implants and retinal implants [1]. Generally, these implants consist of two parts, external and internal parts which are separated by biological human tissue [2].

To avoid the human tissue damage, the operating frequency should be lower than 20 MHz. However, lower operated frequency causes inefficient power and data transmission and lower distance between the external and internal parts [3, 4]. To overcome the challenges above, the sub-electronic circuits of the system should be carefully calculated and designed.

Usually, there are three main modulation forms used in power and to transmit data to the biomedical implantable devices inductively such as amplitude shift keying (ASK), frequency shift keying (FSK) and phase shift keying (PSK) [5].

The ASK forms is the safest way for transferring power and data between the external environment and battery-less implant inductively [6].

In addition, the ASK technology is the simplest, having low power consumption. The ISM standard is dealing with 125-135 kHz, 6,78 MHz, 13,56 MHz, 27,125 MHz and 40,68 MHz, as well as 433,92 MHz, 869 MHz and 2,4 GHz in ultra-high frequency band (UHF), where the ASK forms on a carrier frequency lower than 20 MHz are mostly used to avoid the tissue damage.

There are many studies in which researchers designed inductive coupling links based on ASK forms for bio-medical applications using operated frequency lower than 20 MHz. Gudnason 2000 [7], designed a system with operated frequency 10 MHz, modulation index 10% and modulation rate 2% to transfer data 200 Kb/s of speed. This design suffered from low data rate transmission.

In 2004, Chua et al. [8] proposed a system with operated frequency 2 MHz, modulation index 17,24% and modulation rate 1% to transfer 20 Kb/s of data rate. This structure also suffered from low data rate transmission and low mutual distance.

Jihad et al. 2009 [9], used operating frequency 125-135 KHz to transfer 270 Kb/s of data, where the data information is low. The ISM 6,78 MHz is used to transfer 200 Kb/s based on ON/OFF keying using 1,2  $\mu\text{m}$  MOS technology for bio-medical applications where the data rate is low [10].

The same frequency is used to design efficient inductive coupling link based on geometry for bio-implants applications. However, the design did not provide the data rate transmission [11].

To improve and increase the data transmission, the ISM 13,56 MHz is used to transfer 1 and 1,25 Mb/s of data rate with modulation index up to 18,25% and 13%, respectively [12] and [13].

The higher modulation index caused higher power consumptions. In this paper, and in order to reduce the power consumption, a simple and efficient proposed transcutaneous system with ISM operated frequency 6,78 MHz and new ASKS modulator is used to transfer 500 Kb/s of data with modulation index 12,5% and modulation rate 7,37%.

The proposed system is simple and implementation easy and can be used for bio-implantable devices such as cochlear implants, retinal implants and transcutaneous implantable micro-system.

## 2 SYSTEM DESIGN AND METHODOLOGY

In general, the transcutaneous inductively powering system consists of two parts, external and internal. The external part is fixed outside the human body and touches the skin, whereas the internal part is implanted inside the biological human tissue.

Regarding the proposed system, the external part involves a new ASK modulator, Class-E power amplifier operated at 6,78 MHz and external coil driven by Class-E power amplifier and acts as a transmitter.

The internal part consists of the receiver coil, which is used to power the others implanted remotely, and rectifier to convert the signal from AC to DC voltage with smooth signal. Fig. 1 shows the proposed system design using Pspice software.

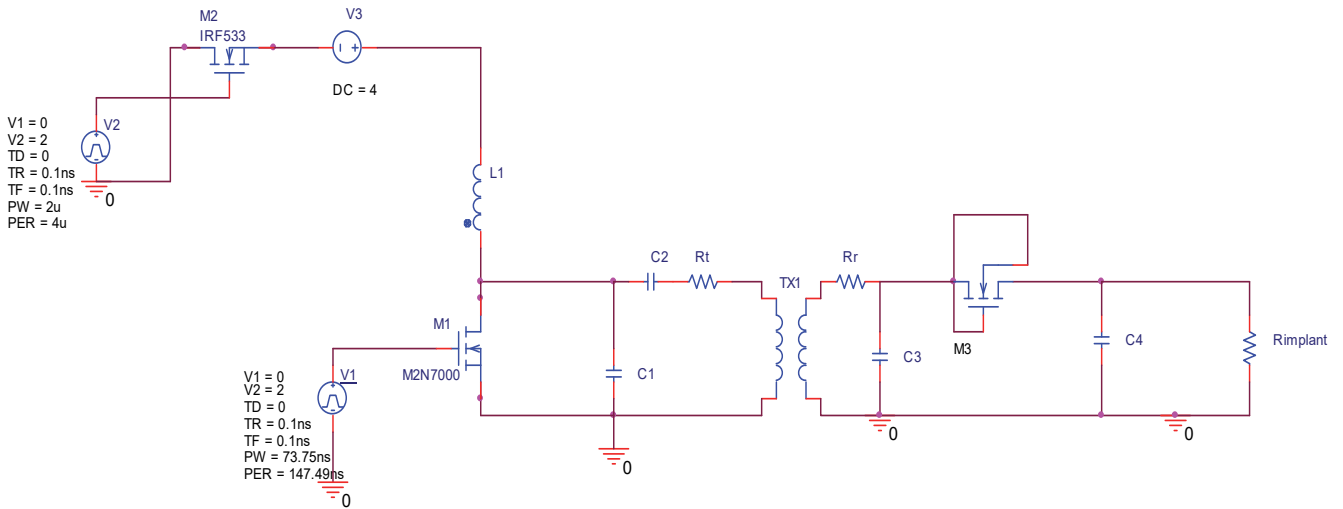

Figure 1 The proposed system architecture

## 2.1 Proposed ASK Modulator

The proposed ASK modulator is simple and efficient; this structure is developed from the research [14], where the diode is removed. In addition, the proposed ASK modulator does not consist of the resistor and two transistors as given by [13]. Hence, removing the passive and active elements will contribute reducing the power consumption. Fig. 2 shows the suggested simple ASK modulator which consists of MOSFET switch  $M1$  (IRF533) and two different voltage sources  $V_1$  and  $V_2$ , respectively.

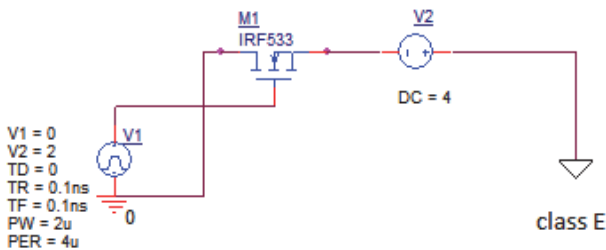

Figure 2 The suggested ASK modulator

The operation principle of the proposed ASK modulator is as follows: The voltage source  $V_1$  is used to generate fixed binary states 0 or 1 of the data with  $T_{bit} = 2 \mu s$  controlled and influenced by switch transistor ( $M1$ ) IRF533. The voltage source  $V_2$  is used to determine the modulation index by determining the high level  $V_H$  and low level  $V_L$  of the ASK amplitude signal as given in Eq. (1).

$$\text{Modulation index} \equiv \frac{V_H - V_L}{V_H + V_L} \cdot 100\% \quad (1)$$

The modulation rate can be calculated as given in Eq. (2)

$$\text{Modulation rate} \equiv \frac{\text{Data rate}}{\text{Operated frequency}} \cdot 100\% \quad (2)$$

The proposed ASK modulator capable of generating the required  $V_{DC}$  to power a Class E amplifier according to

logic state 0 or 1, as given, is the part of the discussion of results.

## 2.2 Class- E Power Amplifier Design at 6,78 MHz

Class-E power amplifier operated by frequency 6,78 MHz ISM band is more suitable to be used for the biomedical applications and bio-telemetry systems in the near field region due to its simplicity and high efficiency [15, 16].

The proposed class-E as shown in Fig. 3 is simple and achieves efficiency up to 94,5%. It contains inductor choke ( $L_1$ ) to provide fixed current and reduce the ripple from the power supply  $V_{DD}$ , one pole MOSFET switch and one shunt capacitor ( $C_1$ ) to ensure zero-voltage switching and remove harmonics of the non-ideal MOSFET switch. To tune a certain frequency 6,78 MHz, these parts are connected with series load network ( $C_2$ ,  $R_{load}$  and  $L_2$ ) which behaves as a transmitting antenna and converts the digital input signal into a stable sinusoidal output and satisfies constant current from the supply source. The inductor  $L_2$  acts as a physical coil to transmit power and data to the implantable device.

To find the values of the optimum load resistance and other passive elements, the delivered power to the implanted device should be known. The mathematical model is presented as follows:

Because the proposed design is for bio-implantable devices, and to avoid the tissue damage the transmitted power is limited due to the tissue absorption where the power should be as small as possible and measured in mW. Therefore, we assumed that the delivered power to the implanted devices ( $p_{out}$ ) is 100 mW,  $f_0$  is 6,78 MHz and  $V_{DD}$  is 3,5 V and the switch with 50% of duty cycle.

To find the optimum power delivered by class-E amplifier, the optimum resistances  $R_{L, opt}$  for the amplifier should be introduced as a known value and can be calculated as given in Eq. (3), [17].

$$R_{L, opt} \equiv \frac{2}{1 + \frac{\pi^2}{4}} \cdot \frac{V_{DD}^2}{p_{out}} \quad (3)$$

The inductor choke ( $L_1$ ) is calculated as given in Eq. (4), [18].

$$L_1 \equiv 2 \left( \frac{\pi^2}{4} + 1 \right) \frac{R}{f} = \frac{7R}{f} \quad (4)$$

The shunt capacitor ( $C_1$ ) and the series capacitor ( $C_2$ ) are calculated by Eqs. (5) and (6), respectively.

$$C_1 \equiv \frac{1}{\omega_0 R_L \left[ \frac{\pi^2}{4} + 1 \right] \left[ \frac{\pi^2}{2} \right]} = \frac{1}{\omega_0 (5,447 R_L)} \quad (5)$$

$$C_2 \equiv C_1 \left[ \frac{5,447}{Q} \right] \left[ 1 + \frac{1,42}{Q - 2,08} \right] \quad (6)$$

For maximum class-E efficiency and constant sinusoidal wave, the quality factor ( $Q$ ) should be consistent with the bandwidth and have value more than 5, [19]. The quality factor for the proposed Class-E amplifier can be calculated as given in Eqs. (7) and (8), respectively.

$$\omega = 2\pi f \quad (7)$$

$$Q \leq \frac{\omega L_2}{R_{L, \text{opt}}} \quad (8)$$

The transmitted coil  $L_2$  is calculated as given in Eq. (9)

$$L_2 = \frac{Q R_{L, \text{opt}}}{\omega_0} \quad (9)$$

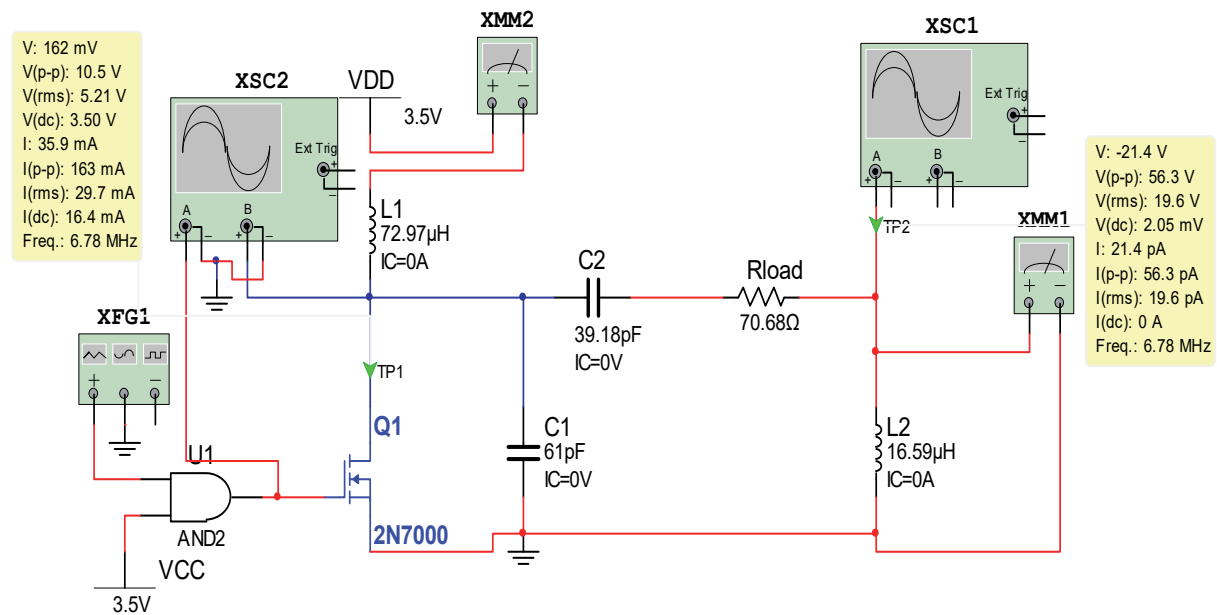

Figure 3 Class-E designs at 6,78 MHz

## 2.2 Inductive Coupling Link Design

The inductive coupling link was designed to transfer the data and power from the external to the internal part. Inductive coupling link contains secondary and primary coils.

There are many topology connections in passive system part such as parallel to parallel, parallel to series, series to parallel and series to series.

In most cases, the primary side is tuned in series resonance to provide a low impedance load for driving the transmitter coil, where the secondary side is almost invariably parallel, and uses an LC circuit for better driving of a nonlinear rectifier load [20]. Hence, the series to parallel topology is chosen in this work.

The optimum resistance  $R_{L, \text{opt}}$  which is calculated in section 2.2 is still large and it is not suitable to be used for subcutaneous applications as a parasitic resistance  $R_t$ . This parasitic resistance has low impedance depending on the coils dimensions such as total length, thickness, constant permeability and relative permeability of the conductor and depth of skin [21, 22].

In the proposed inductive link, and depending on the values above, the transmit coil resistance  $R_t$  is found equal to 4,9  $\Omega$ . Fig. 4 shows the passive component for the proposed series to parallel (SP) inductive link design and for easy explanation the transmit coil  $L_2$  is changed to be  $L_t$ .

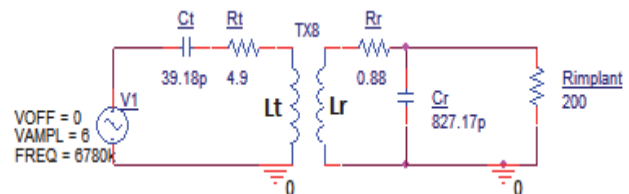

Figure 4 The SP inductive coupling link design

The coefficient of coupling ( $K$ ) must be  $0 < K < 1$  and calculated as given in Eq. (10).

$$K = \frac{M}{\sqrt{L_t L_r}} \quad (10)$$

The primary capacitance ( $C_t$ ) is calculated by Eq. (6). The secondary capacitance ( $C_r$ ) is calculated by equation (11).

$$C_r = \frac{R_{load} + \sqrt{R_{load}^2 - 4\omega_0^2 L_r^2}}{2\omega_0^2 R_{load} L_r} \quad (11)$$

where  $R_{load}$  presents the implanted resistance and should be  $R_{load} > 2\omega L_r$  [12], and  $R_t$ ,  $R_r$  present the transmit and received coils parasitic resistance, respectively. The parasitic resistance  $R_r$  is calculated as given in Eq. (12).

$$R_r = \frac{R_{load}}{1 + \omega_0^2 R_{load}^2 C_r^2} \quad (12)$$

The quality factor for the transmit and received coils  $Q_t$  and  $Q_r$  is based on resonance frequency, coil inductance and parasitic resistance and calculated as given in Eqs. (13) and (14), respectively.

$$Q_t = \frac{\omega_0 L_t}{R_t} \quad (13)$$

$$Q_r = \frac{\omega_0 L_r}{R_r} \quad (14)$$

The efficiency for the transmitted and received coil can be calculated as given in Eqs. (15) and (16), respectively, whereas the total coupling efficiency is calculated as given in Eqs. (17) and (18), respectively.

$$\eta_t = \frac{K^2 Q_t Q_r R_{load}}{K^2 Q_t Q_r R_{load} + Q_r^2 R_r} \quad (15)$$

$$\eta_r = \frac{Q_r^2 R_r}{Q_r^2 R_r + R_{load}} \quad (16)$$

$$\eta_{total} = \eta_t \times \eta_r \quad (17)$$

$$\eta_{total} = \frac{K^2 Q_t Q_r^3 R_r R_{load}}{K^2 Q_t Q_r^3 R_r R_{load} + K^2 Q_t Q_r R_{load}^2 + Q_r^4 R_r^2 + 2Q_r^2 R_r R_{load} + R_{load}^2} \quad (18)$$

### 2.3 Proposed Rectifier for the Internal Power Recovery

The bio-implantable devices require an efficient voltage rectifier to convert the RF signal to DC V. The first sub-circuit in the internal part is the rectifier. There are many kinds of rectifiers used in the implanted devices such as Schottky diode rectifier and full wave rectifier. These rectifiers cause low efficiency and take large area in implanted devices. The voltage doubling rectifier was presented with two MOSFET by using self-threshold voltage cancelation [13]. This rectifier suffers from large size area and more power consumption. To overcome the challenges above, the voltage doubling rectifier with one edited NMOSFET is presented. The transistor editing is done using Pspice software and included the channel length ( $L = 0,35 \mu\text{m}$ ) and width ( $W = 100 \mu\text{m}$ ). The transistor NMOSFET acts as a diode to rectify the received ASK as shown in Fig. (5). This structure has low power consumption and smaller size in the area of implanted parts.

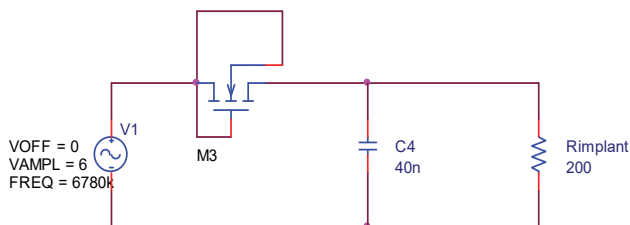

Figure 5 Voltage-doubling rectifier structures

## 3 RESULTS AND DISCUSSIONS

This paper introduces a simple and efficient transcutaneous system which is used to power and transmit data to the subcutaneous system. The proposed transcutaneous system involves two parts, external and

internal part. The external part consists of pulse data generator, new ASK modulator and class-E, power amplifier operated at 6,78 MHz and transmitted coil to transmit the power and data to the implantable devices. Whereas the internal part consists of received (implanted) coil and rectifier to convert AC to DC voltage with smooth signal and resistor which presents the implanted device resistance as shown in Fig. 1. The data generator generates fixed binary sequence which is controlled and influenced by switch transistor ( $Q_1$ ). In this paper a new ASK modulator without passive elements as shown in Fig. 2 is developed to modulate the input data and power the Class-E amplifier with 3-4 V (DC) as shown in Fig. 6

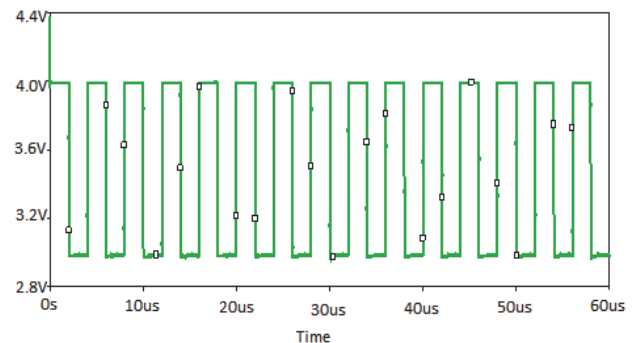

Figure 6 The ASK generated power output to supply the Class-E amplifier

The class-E switch (M1) operation is as follows: the Drain- Source voltage is equal (0) when the switch is in active state (1) and Gate-Source voltage is (1) when the switch is in the state (0), and offers stable sinusoidal wave signal to the transmitted coil as shown in Fig. 7 and 8, respectively.

The Class-E efficiency is performed from the simulation where  $V_{rms} = 19,6 \text{ V}$ ,  $I_{dc} = 16,4 \text{ mA}$ .

$$P_{\text{outavg}} = \frac{V_{\text{rms}}^2}{R_{L, \text{opt}}} \quad (19)$$

The class-E efficiency can be calculated as given in Eq. (20).

$$\eta_{\text{class-E}} = \frac{P_{\text{outavg}}}{P_{\text{in}} + P_{\text{dc}}} \quad (20)$$

The input power ( $P_{\text{in}}$ ) is very small compared with dc power ( $P_{\text{dc}}$ ) so will be neglected. Therefore, the efficiency for class-E with optimum resistance is 94,5%.

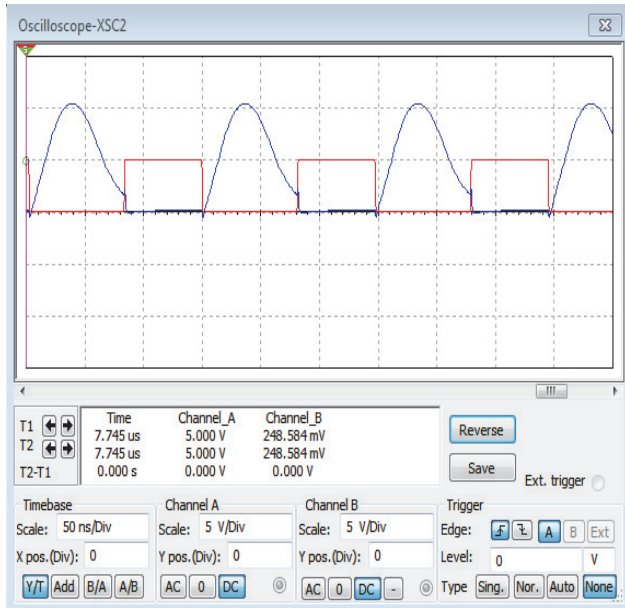

Figure 7 The Class-E switching activity

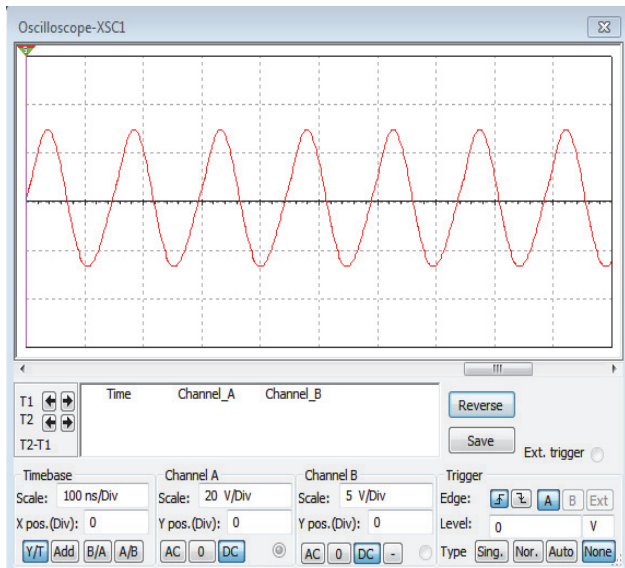

Figure 8 The stable class-E amplifier output sinusoidal waveform

To design efficient inductive coupling link, several factors should be taken into account, these factors include: link efficiency, link voltage gain, communication bandwidth and coils size. Because the proposed design is based on coupling not geometry, therefore, the "voltage in-voltage out" link is an approach which can control the

output gain. This approach is based on coupling, not geometry. Therefore, the results for the inductive link are based on factors link voltage gain, communication bandwidth and link efficiency. Referring to Fig. 4, the transmitted coil  $L_1$  presents the external coil for the inductive link and acts as an antenna to transmit the modulated ASK signal with  $V_H = 27 \text{ V}$  and  $V_L = 21 \text{ V}$  with modulation index 12,5% as shown in Fig. 9.

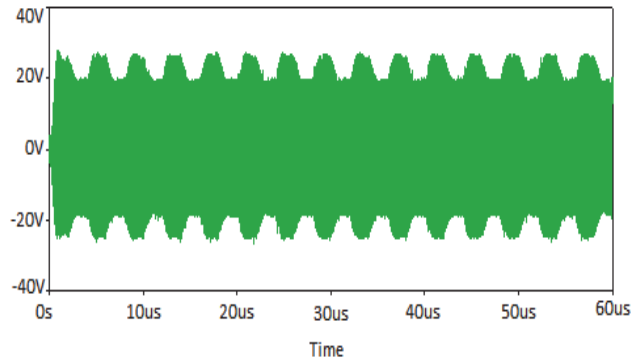

Figure 9 The transmitted ASK signal with modulation index 12,5%

The received coil  $L_2$  in the internal part presents the implanted coil and receives the ASK signal inductively with  $V_H = 6$  and  $V_L = 4,65 \text{ V}$  with modulation index 12,5% as shown in Fig. 10. Both transmit and receive coils have the same modulation index and this contributes to reduce the system power consumption.

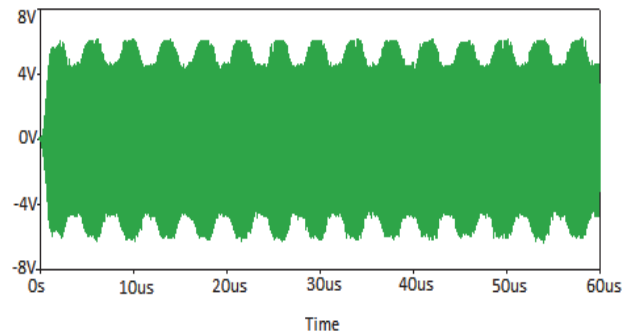

Figure 10 The received ASK signal with modulation index 12,5%

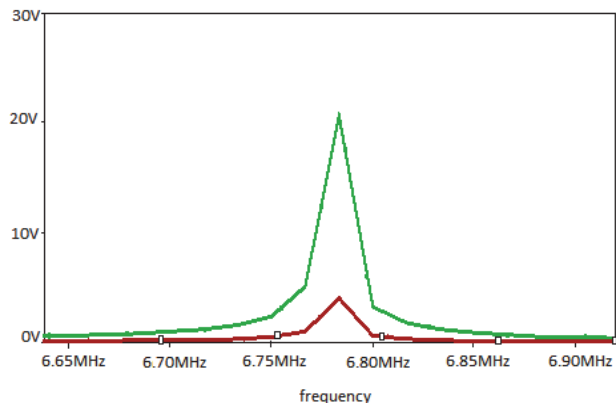

Figure 11 Both coils tuned at the same resonance frequency 6,78MHz

To get better link efficiency, both primary and secondary RLC circuits for the inductive link are tuned at the same resonance frequency with bandwidth approximately 500 KHz, which is in fact the chosen operated frequency 6,78 MHz as shown in Fig. 11.

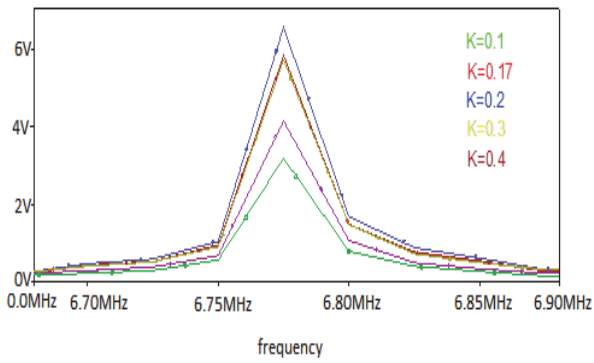

Figure 12 Relationships between the voltage gain and frequency based on variable coupling coefficient

A better coupling coefficient ( $K$ ) for the proposed link is found 0,17, and to find the relationship among the voltage gain, bandwidth and coupling coefficient at a frequency of approximately 6,78 MHz, the voltage gain for the proposed inductive link for some chosen coupling coefficient ( $K$ ) values such as (0,1; 0,17; 0,2; 0,3 and 0,4) at a fixed load of 200  $\Omega$  is plotted as shown in Fig. 12.

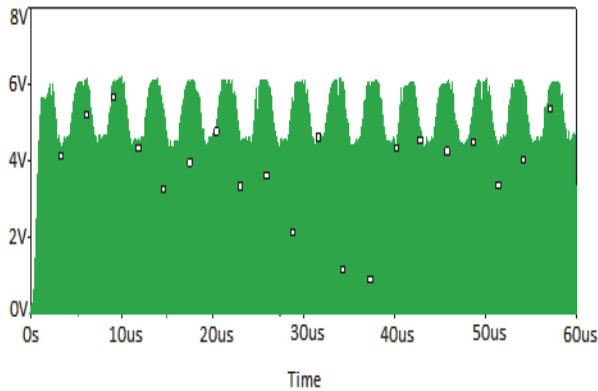

Figure 13 The rectified ASK signal

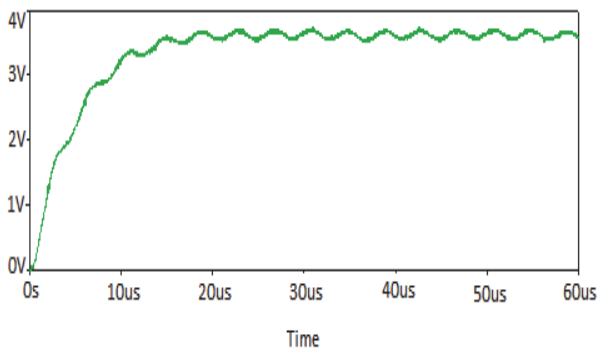

Figure 14 The smoothed rectified ASK signal

According to this simulation, the inductive coupling link acts as a band-pass filter at the central frequency 6,78 MHz. The analysis of this plot shows that the voltage gain is reduced by reducing  $K$  and vice-versa and the bandwidth is approximately 500 KHz. The proposed rectifier with one edited device provides a rectified ASK signal with  $V_H = 6$  and  $V_L = 4,65$  as shown in Fig. 13. This signal is soothed by small capacitor to provide DC V as shown in Fig. 14.

Tab. 1 shows the values of the proposed system, and to calculate the total inductive coupling efficiency according to Eq. (16) the MATLAB is used. Because of  $R_{load} > 2\omega L$

the  $R_{load}$  should be higher than 55,692  $\Omega$ . The implanted load resistor is considered 100  $\Omega$  to 400  $\Omega$  and the coupling coefficient is 0,17.

Table 1 The values of the proposed system

Description	Symbol	Value
Primary inductance	$L_t$	16,59 $\mu$ H
Secondary inductance	$L_r$	0,654 $\mu$ H
Optimum resistance load	$R_{L,opt}$	70,68 $\Omega$
Primary resistance	$R_t$	4,9 $\Omega$
Secondary resistance	$R_r$	0,88 $\Omega$
Primary capacitance	$C_t$	39,18 PF
Secondary capacitance	$C_r$	827,17 PF
Quality factor (Class-E)	$Q$	9,99
Quality factor (transmitter)	$Q_t$	144,15
Quality factor (receiver)	$Q_r$	31,64
Resonant frequency	$f_0$	6,78 MHz
Coupling coefficient	$K$	0,17
Class-E efficiency	$\eta_{amplifier}$	94,5%
Transmitted coil efficiency	$\eta_t$	96,76%
Received coil efficiency	$\eta_r$	81,49%
Total coupling efficiency	$\eta_{total}$	67,14-83,59%
Efficiency at 200 $\Omega$	$\eta$	78,29%
Modulation index	-	12,5%
Modulation rate	-	7,37%

Fig. 15 is plotted in MATLAB and shows the variation of power efficiency with various resistances and coefficient factors. The maximum efficiency when the coupling coefficient 0,17 is 83,59% performed when the implanted resistance equals 100  $\Omega$ , and the minimum efficiency is 67,14% is performed when the implanted resistance is equal to 400  $\Omega$ . For our proposed values  $K = 0,17$  and  $R_{load} = 200 \Omega$ , the power transmission efficiency is found to be approximately 78,29%.

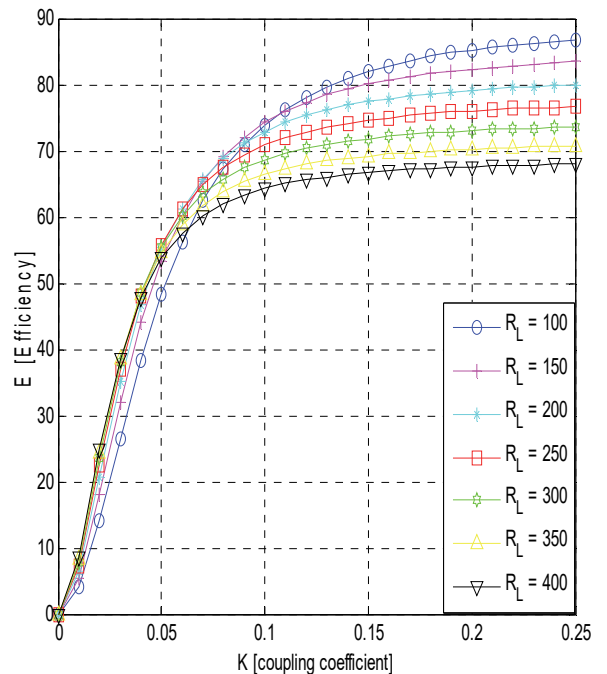

Figure 15 The power transmission efficiency modelled in MATLAB

To verify the performance of the proposed system, a figure of merit (FOM) and comparison with other studies is performed as given in Tab. 2. The proposed system performance is better than in other studies.

**Table 2** The performance of the system compared with other works

References	[10] 1998	[7] 2000	[8] 2004	[24] 2011	[13] 2014	Propose
CMOS / $\mu$	1,2	0,5	0,35	0,35	0,35	0,35
Car. freq. / MHz	6,78	10	2	10	13,56	6,78
Data rate / kb/s	200	200	20	1000	1000-1250-1500	500
Modu. index / %	N/A	10	10,34-17,24	20	13	12,5
Modu. rate / %	N/A	2	1	10	7,3-9-11	7,37
$\eta_{\text{coupling link}}$ / %	20	N/A	N/A	N/A	53,25	78,29
$\eta_{\text{Class-E}}$	N/A	N/A	N/A	N/A	87,2	94,5
FOM	N/A	2	0,58-0,967	0,5	0,958-1,277	0,589

#### 4 CONCLUSION

In this paper, a simple and efficient inductive power for Micro-System based on ASK modulator is designed. The proposed system operated with ISM low-band frequency at 6,78 MHz to avoid the heating and damage in tissue of a human. A new ASK modulator is proposed to model the input data and provide a stable DC voltage to power the high efficient class-E power amplifier. The high efficient class-E power amplifier with efficiency 94,5% and efficient inductive link 78,29% of efficiency were used to transmit the ASK signal with data rate up to 500 Kbit/s to the implanted device. The total coupling efficiency is 67,14-83,59% with modulation index 12,5% and modulation data 7,37%, this lead to reduce the power consumption of this system. The system was designed and simulated by OrCADpspice software 16,6 and electronic workbench MULTISIM 11. The proposed system may be useful for implantable micro-system, retinal implants and cochlear implants.

#### Acknowledgements

This work supported by the University Putra Malaysia.

#### 5 REFERENCES

- [1] Hannan, M. A., Mutashar, S., Samad, S. A., & Hussain, A. (2014). Energy harvesting for the implantable biomedical devices: issues and challenges. *Biomedical Engineering*, 13, 13-79. <https://doi.org/10.1186/1475-925X-13-79>
- [2] Zierhofer, C. M. & Hochmair, E. S. (1990). High-efficiency coupling-insensitive transcutaneous power and data transmission via an inductive link. *Biomedical Engineering, IEEE Transactions on*, 37, 716-722. <https://doi.org/10.1109/10.55682>
- [3] Zargham, M. & Maximum, P. G. (2012). Achievable Efficiency in Near-Field Coupled Power-Transfer Systems. *Biomedical Circuits and Systems, IEEE Transactions on*, 6, 228-245. <https://doi.org/10.1109/TBCAS.2011.2174794>
- [4] Karacolak, T., Cooper, R., & Topsakal, E. (2009). Electrical Properties of Rat Skin and Design of Implantable Antennas for Medical Wireless Telemetry. *Antennas and Propagation, IEEE Transactions on*, 57, 2806-2812. <https://doi.org/10.1109/TAP.2009.2027197>
- [5] Hannan, M. A., Mutashar, S., Samad, S. A., & Hussain, A. (2011). Modulation techniques for biomedical implanted devices and their challenges. *Sensors*, 12, 297-319. <https://doi.org/10.3390/s120100297>
- [6] Zhu, F., Gao, S., Ho, A. T. S., See, C. H., Abd-Alhameed, R. A., Li, J. et al. (2012). Design and analysis of planar ultra-wideband antenna with dual band-notched function. *Progress in Electromagnetics Research*, 127, 523-536. <https://doi.org/10.2528/PIER12033105>
- [7] Gudnason, G. (2000). A low-power ASK demodulator for inductively coupled implantable electronics. *Solid-State Circuits Conference, Proceedings of the 26<sup>th</sup> European*, 385-388.
- [8] Chua-Chin, W., Ya-Hsin, H., Chio, U. F., & Yu-Tzu, H. (2004). A C-less ASK demodulator for implantable neural interfacing chips. *Proceedings of the 2004 International Symposium on*, 57-60. <https://doi.org/10.1109/ISCAS.2004.1328939>
- [9] Elamare, G. (2010). Investigation of high bandwidth bio devices for transcutaneous wireless telemetry. *PhD thesis*, New Castle University.
- [10] Smith, B., Zhengnian, T., Johnson, M. W., Pourmehdi, S., Gazdik, M. M., Buckett, J. R. et al. (1998). An externally powered, multichannel, implantable stimulator-telemeter for control of paralyzed muscle. *Biomedical Engineering, IEEE Transactions on*, 45, 463-475. <https://doi.org/10.1109/10.664202>
- [11] Harrison, R. R. (2007). Designing Efficient Inductive Power Links for Implantable Devices. *Circuits and Systems Conference. ISCAS 2007. IEEE International Symposium on*, 2080-2083. <https://doi.org/10.1109/ISCAS.2007.378508>
- [12] Hmida, G. B., Ghariani, H., & Samet, M. (2007). Design of wireless power and data transmission circuits for implantable biomicrosystem. *Biotechnology*, 6, 153-164. <https://doi.org/10.3923/biotech.2007.153.164>
- [13] Mutashar, S., Hannan, M., Samad, S., & Hussain, A. (2014). Development of Bio-Implanted Micro-System with Self-Recovery ASK Demodulator for Transcutaneous Applications. *Journal of Mechanics in Medicine and Biology*, 14, 1450062. <https://doi.org/10.1142/S0219519414500626>
- [14] Son, Y.-H. & Jang, B.-J. (2013). Simultaneous data and power transmission in resonant wireless power system. *Microwave Conference Proceedings (APMC)*, 1003-1005. <https://doi.org/10.1109/APMC.2013.6695004>
- [15] Mutashar, S., Hannan, M., & Salina, A. (2012). Efficient Class-E design for inductive powering wireless biotelemetry applications. *International Conference on Biomedical Engineering (ICoBE)*, 445-449.
- [16] Raab, F. H. (1978). Effects of circuit variations on the class E tuned power amplifier. *IEEE Journal of Solid-State Circuits*, 13, 239-247. <https://doi.org/10.1109/JSSC.1978.1051026>
- [17] Lee, H. T. (2004). *The design of CMOS radio-frequency integrated circuits*. Cambridge university press. <https://doi.org/10.1017/CBO9780511817281>
- [18] Suetsugu, T. & Kazimierczuk, M. K. (2004). Analysis and design of class E amplifier with shunt capacitance composed of nonlinear and linear capacitances. *Circuits and Systems I: Regular Papers, IEEE Transactions on*, 51, 1261-1268. <https://doi.org/10.1109/TCSI.2004.830695>
- [19] Sekiya, H., Arifuku, Y., Hase, H., Jianming, L., & Yahagi, T. (2005). Design of class E amplifier with any output Q and nonlinear capacitance on MOSFET. *Circuit Theory and Design, Proceedings of the 2005 European Conference on*, III/105-III/108. <https://doi.org/10.1109/ECCTD.2005.1523071>
- [20] Johnson, D. E. (2006). *Basic Electric Circuit Analysis*. John Wiley & Sons, Inc.

- [21] Noor, F. & Duffy, M. (2010). Amplifier design for a biomedical inductive power system. *Signals and Systems Conference (ISSC 2010), IET Irish*, 169-174.  
<https://doi.org/10.1049/cp.2010.0507>
- [22] Uei-Ming, J. & Ghovanloo, M. (2007). Design and Optimization of Printed Spiral Coils for Efficient Transcutaneous Inductive Power Transmission. *Biomedical Circuits and Systems, IEEE Transactions on, 1*, 193-202.  
<https://doi.org/10.1109/TBCAS.2007.913130>
- [23] Finkensteller, K. (2003). *Fundamentals and Applications in Contactless Smart Cards and Identification*. Hoboken.
- [24] Daoud, D., Ghorbel, M., Ben Hamida, A., & Tomas, J. (2011). Fully integrated CMOS data and clock recovery for wireless biomedical implants. *Systems, Signals and Devices (SSD), 8<sup>th</sup> International Multi-Conference on*, 1-5.  
<https://doi.org/10.1109/SSD.2011.5767400>

**Contact information:**

**Mokhalad Khaleel ALGHRAIRI**

(Corresponding author)

1) Department of Electrical and Electronic Engineering,  
Faculty of Engineering University Putra Malaysia,  
43400 UPM Serdang, Selangor Darul Ehsan, Malaysia  
2) Imam Kadhim College Islamic Science University  
E-mail: mokhalad.khaleel@alkadhim-col.edu.iq

**Nasri Bin SULAIMAN**

Department of Electrical and Electronic Engineering,  
Faculty of Engineering University Putra Malaysia,  
43400 UPM Serdang, Selangor Darul Ehsan, Malaysia  
E-mail: nasri\_sulaiman@upm.edu.my

**Roslina Bt Mohd SIDEK**

Department of Electrical and Electronic Engineering,  
Faculty of Engineering University Putra Malaysia,  
43400 UPM Serdang, Selangor Darul Ehsan, Malaysia  
E-mail: roslinams@upm.edu.my

**Saad MUTASHAR**

Department of Electrical Engineering,  
University of Technology, Iraq  
E-mail: Saad.m.abbas@uotechnology.edu.iq