

Numerical Analysis of the Temperature Field in the Cutting Zone in Continuous and Discontinuous Metal Cutting by Turning

Miroslav LUČIĆ, Bogdan NEDIĆ*, Vlatko MARUŠIĆ, Jelena BARALIĆ, Andjelija MITROVIĆ

Abstract: Temperature of cutting is a very important indicator of the cutting process. High specific pressures and high temperatures in the narrow cutting zone result in a drop of hardness of the tool material, the intensification of the abrasion and deformation of the cutting elements, losing the cutting abilities, and finally the failure of the cutting tool. The aim of this paper is to calculate the temperature fields using the existing numerical models for the simulation of thermodynamic processes on the wedge of the cutting tool (based on the finite element method). A special accent is given to the numerical calculation of temperatures in the conditions of continuous and discontinuous turning for specific cutting conditions (processing regime, tool geometry and thermo-mechanical characteristics of the tool materials and workpiece materials) using different simulation models. The Third Wave AdvantEdge software package was used for the simulation of orthogonal turning, and some of the results of the calculations of the temperature fields were compared with the results of experimental measurements.

Keywords: contact tool/chips; continuous and discontinuous turning; finite element method; temperature analysis

1 INTRODUCTION

Cutting of metal is the most complex part of the technological process of making machine parts of the desired shape and dimensions. By introducing modern high-performance CNC processing systems, there is a constant tendency to reduce the main time of production by increasing the processing regime and by increasing the stability and total life of the cutting tool. Cutting tool is a subsystem of the processing system, and the failure of the cutting tool results in a delay in the work of the whole system. The failure of the tool depends on a whole range of factors and is a very complex phenomenon. The time to failure of the cutting tool is not constant, but it is a random variable that can be predicted.

Generated heat in the cutting zone heats the workpiece, metal chips and cutting tools. The analysis of thermal phenomena shows that the largest amount of heat is generated in the deformation zone (shear zone) and on the contact of rake face of the cutting tool and metal chips. Those are precisely the areas to which many researchers in their studies of the cutting processes devote considerable attention [1, 2]. A particularly negative effect has the heat that is transferred into the tool. As a result, there is a decrease in the hardness of the tool material, resulting in more intensive abrasion and plastic strain of the cutting elements of the tool, and consequently loss of cutting abilities. Therefore, knowledge of the values and the distribution of the temperature in the tool is of great practical significance [3-5]. This allows, among other things, to explore some guidelines of the implementation of using cryogenic conditions and systems based on a thermoelectric module for cooling the cutting tool [6, 7].

Numerical solutions, related to cutting operations, provide economically far more favorable conditions for understanding the cutting processes. The main advantage of this approach is that the models are based on the physical properties of the materials of the tools and objects being processed, and changes in the output parameters of the cutting process can be successfully predicted by varying of the initial data. The limitation of this approach is linked to the ability of the model to adapt to the complexity of the cutting process [8-10].

Modern processing systems imply CNC processing with variable processing parameters under continuous and discontinuous cutting conditions. CNC processing involves the continuous entry and exit of the tool in the operation with the workpiece. Therefore, the focus is on numerical analysis of the temperatures of the contact tool - metal chips and cutting temperatures. Third Wave AdvantEdge software was used for numerical analysis. The characteristics of the tool and the workpiece are defined according to the data from the paper [11], and the calculated temperature values are compared with the experimental results from the listed paper. The goal of the research realized in this paper is to make progress towards the development of numerical models for the calculation of the temperatures in conditions of continuous and discontinuous cutting in turning processing.

2 GENERATING THE HEAT IN THE CUTTING ZONE

When processing the metal by cutting, the total mechanical work is spent on deforming and removal of the material of the workpiece and friction control in the cutting process. The appearance of heat in the cutting zone is a result of the conversion of mechanical energy into heat energy. Thermal phenomena significantly affect the intensity of the abrasion of the cutting elements of the tool, etc., the quality and economy of the processing. More than 95% of the energy (mechanical work) consumed in the process of cutting in deforming the material of the workpiece and overcoming the friction on the contact surfaces of the cutting tool wedge turns into heat. Up to 90% of the generated heat is taken off with metal chips, while the other part is transferred to the tool and workpiece. Determining the temperature of cutting and its distribution is of great importance (Fig. 1a). Affecting the changes in the structure of the material being processed (and thus the quality of the treated surface), high temperature also affects the changes in the structure of the material of the cutting tool, which negatively affects the abrasion of the same tool. From the aspect of quality and cost of processing, it is most important to know the maximum temperature on the cutting tool.

The heating temperatures of the rake face of the cutting tool are shown in Fig. 1b, [12]. The picture shows that the area of maximal heating of the chest surface of the tool is a little distant from the cutting edge, which theoretically corresponds to the area of maximum tool abrasion (tool

wearing in the form of a crater). The picture also shows that the isothermal surfaces have a shape similar to elliptical surfaces such as Liu, Chou & Filice previously observed [11].

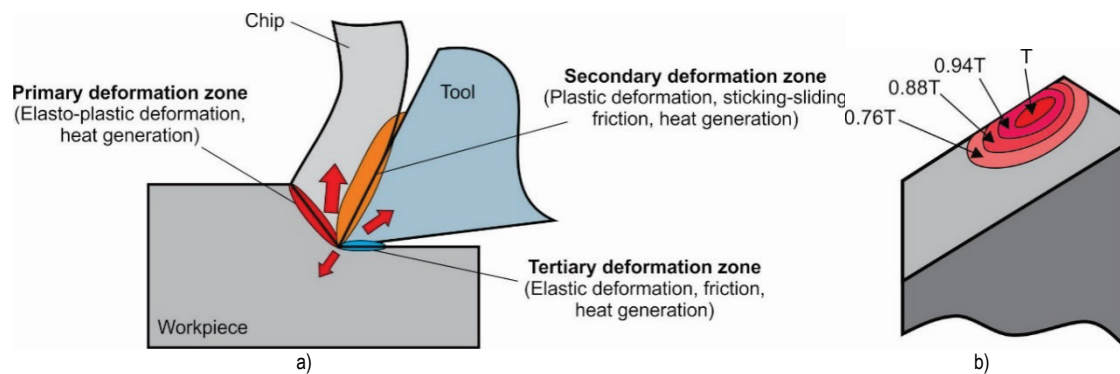

Figure 1 a) Heat generation zones and distribution in processing by turning; b) distribution of the temperature on the cutting tool

3 CONDITIONS OF PROCESSING WITH THERMAL SIMULATION

In this paper are applied processing conditions to simulate cutting temperatures [11]. The processing operation is fine longitudinal turning, without cooling. Processing workpiece is a round bar made of structural steel, quality C45 (AISI 1045). Cutting tool is a lathe tool with removable hard metal tool plate TCMW16T304, quality K20 with ISO holder STGCL2525 M16. Cutting geometry: rake face angle $\gamma = 0^\circ$, back rake angle $\alpha = 6^\circ$, relief angle $\lambda = 0^\circ$ and radius of the peak of the plate $r_c = 0,8$ mm. Turning is done under the following conditions:

- cutting speed: $v_c = 300$ m/min
- depth of cut: $a_p = 1,1$ mm
- feed: $f = 0,1$ mm/o

The thermophysical properties of the tool plate and the workpiece were adopted according to Tab. 1 [11].

Table 1 The thermophysical properties of the tool plate and the workpiece

Thermophysical properties of the tool insert						
Temperature / °C	20	100	200	300	500	600
Conductivity / W/m °C	117	110	97	86	85	83
Specific heat / J/kg °C	222					
Density / kg/m ³	14900					
Thermophysical properties of the workpiece						
Conductivity / W/m °C	54					
Specific heat / J/kg °C	486					
Density / kg/m ³	7800					

Experimental temperature measurement was performed by thermocouples on CNC lathe. For this work, the TC1 thermocouple location is taken because it is incorporated into the tool plate near the main cutting edge at the point of contact of the tool - metal chips (on the rake face side approximately 0,5 mm from the main cutting edge). For the given processing regime, the measured value of the maximal temperature at the thermocouple TC1 is 420 °C [11].

4 SIMULATION OF CONTINUOUS AND DISCONTINUOUS TURNING PROCESS

One of the examples of discontinuous turning is the longitudinal processing of the cylindrical part with longitudinal straight grooves, Fig. 2 (e.g., grooved shaft).

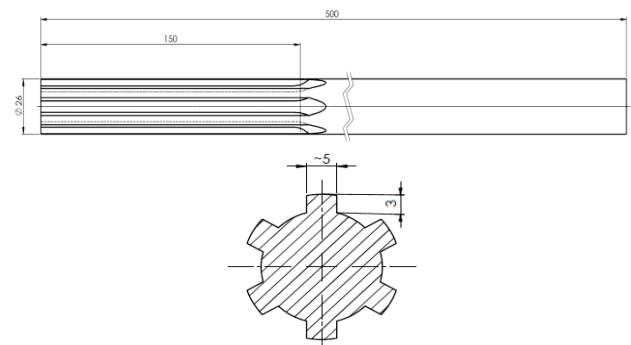

Figure 2 Real grooves on the round rod

Cutting processing simulations are based on the energy generated in contact tool - metal chips, etc., cutting forces and cutting temperatures (contact tool - metal chips and on the very tool) [10, 13]. For the purpose of a more complete analysis of numerical studies for simulations in the Third Wave AdvantEdge program, two mathematical models related to thermo-mechanical characteristics of the workpiece were used [14, 15].

The first model is the **Power Law (PL)** model where the change in voltage during cutting is in function of the current temperature and plastic strain of the material of the workpiece. The second is the **Johnson-Cook (JC)** model where the change in the voltage on the workpiece is defined based on plastic strains and viscous damping in the function of temperature change.

The material of the workpiece is modelled as isotropically elastic-plastic with isotropic reinforcement at stress. In the process of cutting, strain of the material in the primary and secondary cutting zone occurs at higher temperatures and high values of deformation speed ($10^5 \div 10^7$ s⁻¹), [16]. The rest of the material of the workpiece is

deformed at moderate or even low values of the deformation speed.

In the **Power Law** model, the change in the yield stress in the contact cutting zone is defined using a known Eq. (1) applied in many expert papers as a simulation model [17].

$$\sigma_f(\epsilon_p) = \sigma_o \theta(T) \left(1 + \frac{\epsilon_p}{\epsilon_p^o} \right)^{1/n} \quad (1)$$

$$\theta(T) = C_0 + C_1 T + C_2 T^2 + C_3 T^3 + C_4 T^4 + C_5 T^5 \quad (2a)$$

$$\theta(T) = \theta(T_{cut}) \left(1 - \frac{T - T_{cut}}{T_{melt} - T_{cut}} \right) \quad (2b)$$

where are: σ_f , Pa - yield stress; σ_o , Pa - initial yield stress ($4,01 \times 10^8$); ϵ_p - plastic strain; ϵ_p^o - reference plastic strain (0,00191); n - strain hardening exponent (4,9); $\theta(T)$ - thermal softening index (Eq. (2a) and Eq. (2b)), where the Eq. (2a) is defined for $T < T_{cut}$ and Eq. (2b) for $T \geq T_{cut}$; $C_0 \div C_5$ - coefficients for the polynomial fit $\theta(T)$ ($C_0 = 1,062$; $C_1 = -7,62 \times 10^{-5}$; $C_2 = 1,2 \times 10^{-6}$; $C_3 = 8 \times 10^{-10}$; $C_4 = 0$ and $C_5 = 0$); T , °C - room temperature (20 °C); T_{cut} , °C - linear cut off temperature $\theta(T)$ (625 °C); T_{melt} , °C - melting temperature (1500 °C).

Number values enter parentheses refer to the quality of the workpiece (C45).

The **Johnson-Cook** simulation model is also widely used in various software tools to evaluate the individual output parameters of the cutting processes (forces, temperatures, abrasion, ...) and is defined by the Eq. (3) [18-20].

$$\sigma = \left[A + B(\epsilon_p)^n \right] \left[1 + C \cdot \ln \left(\frac{\dot{\epsilon}}{\dot{\epsilon}_o} \right) \right] \left[1 - \left(\frac{T - T_{ref}}{T_{melt} - T_{ref}} \right)^m \right] \quad (3)$$

The values of individual parameters in expression (3) are shown in Tab. 2.

Table 2 Parameter values for Johnson-Cook model

Parameter	$\dot{\epsilon}_o / s^{-1}$	$T_{ref} / ^\circ K$	$T_{melt} / ^\circ K$	A / MPa	B / MPa	n	C	m
Value	0,0015	298	1793	230	1260	0,43	0,03	0,9

In Tab. 2 are: σ , Pa - equivalent stress; $\dot{\epsilon}$, s^{-1} - strain rate; $\dot{\epsilon}_o$, s^{-1} - reference strain rate; T , °C - temperature of the sample; T_{ref} , K - room temperature; A , MPa - yield stress of the material at a reference deformation conditions; B , MPa - strain hardening coefficient; C - strain rate strengthening coefficient; n - strain hardening constant; m - thermal softening coefficient.

For the purposes of numerical analysis of the cutting process for continuous longitudinal turning, 2D simulation models of the strain zone are defined, shown in Figs. 3a and 3b. The processing length in this case is $L = 5$ mm.

On the indicated models for continuous cutting (Figs. 3a and 3b) it is noticed that the appearance of the metal chip is not the same. These differences further contribute to differences in the calculated temperature values in the contact zone tool-chip.

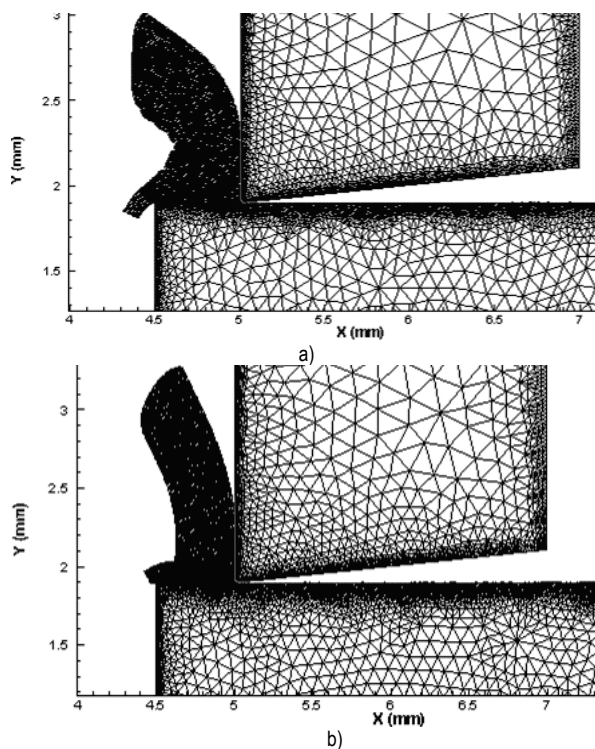

Figure 3 Simulation model for continuous cutting: a) Power Law model; b) Johnson-Cook model

Fig. 4 shows the 2D simulation model of the strain zone for the numerical analysis of the cutting process in discontinuous longitudinal turning defined in this paper and is the same for both the Power Law model and the Johnson-Cook model. The processing length is $L_o = 1$ mm and the length without processing is also $L_p = 1$ mm.

On the models shown (Figs. 3 and 4), the workpiece and tool are discretized with triangular isoparametric finite elements (KE) with 6 nodes. The minimal length of the KE is 0,02 mm and the maximal is 0,1 mm. The maximum number of nodes is 24000.

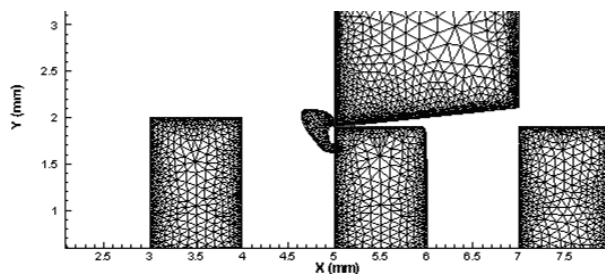

Figure 4 Simulation model for discontinuous cutting

5 RESULTS AND DISCUSSION

The results of the calculation of temperature fields by numerical simulations are most often shown diagrammatically, and can also be presented in the form of temperature fields. Thermal simulations allow estimation of temperature of the tools, metal chips, workpiece and tool-chip contact [3].

In this paper, the numerical values of the temperatures obtained according to the realized numerical analysis and according to the simulation models of Power Law and Johnson-Cook in the continuous cutting are observed at the spot where the thermocouple *TC1* is located (Fig. 5).

In cutting mode: turning speed 300 m/min, feed 0,1 mm/o and cutting depth 1,1 mm, the maximal measured temperature at the location *TC1* is 420 °C [11].

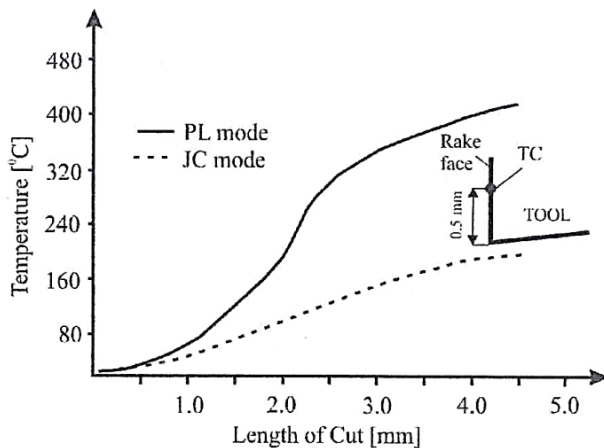

Figure 5 Numerical temperature values at *TC1* at continuous cutting ($v_c = 300$ m/min, $a_p = 1,1$ mm, $f = 0,1$ mm/o)

Fig. 5 shows that the numerical values of maximal calculated temperature at the thermocouple setting location, using the Power Law simulation model, are consistent with the experimental value, while using the Johnson-Cook model calculated temperature is lower (it is around 200 °C). This leads to the conclusion that the results of thermal simulations for the discontinuous turning of structural steel C45 with the same tool and processing regime will be more accurate using the Power Law simulation model, or they may be relevant for further numerical analysis.

Figs. 6 and 7 show the change of the maximal calculated cutting temperature on the cutting tool wedge from the cutting length (tool path), for continuous and discontinuous processing, for both simulation models.

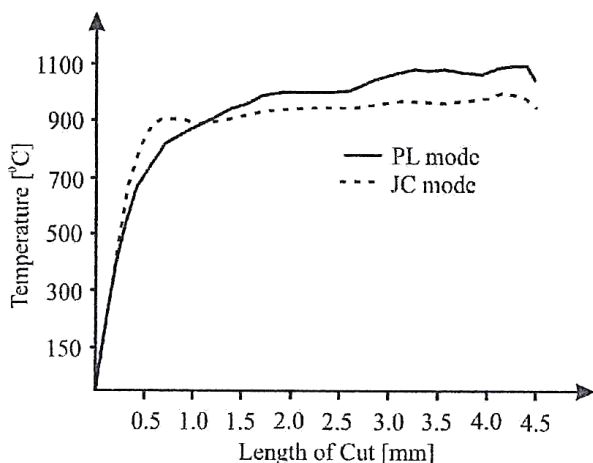

Figure 6 Numerical temperature values for continuous cutting

In Figs. 6 and 7, it is observed that a stable cutting temperature is achieved after the tool has passed about 4,5 mm in continuous cutting, while the stable temperature is not achieved at the discontinuous processing. In the case of

discontinuous metal processing, the maximum temperature, in the case of no processing (groove, empty space), decreases rapidly, and then increases when the next surface is being processed. This way of heating and cooling of the tools influences the maximum cutting temperature to be lower in the discontinuous processing compared to the continuous, which is expected.

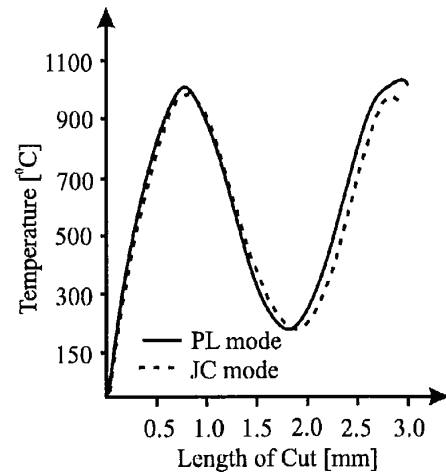

Figure 7 Numerical temperature values for discontinuous cutting

The diagram shown in Fig. 8 shows a change in the maximum temperature value along the rake face surface (0 to 1 mm in length, perpendicular to the cutting edge of the tool) in the contact zone tool - metal chip. The diagram shows that the maximum temperatures in both simulation models are in the immediate proximity of the cutting edge, that is, the cutting edge of the tool.

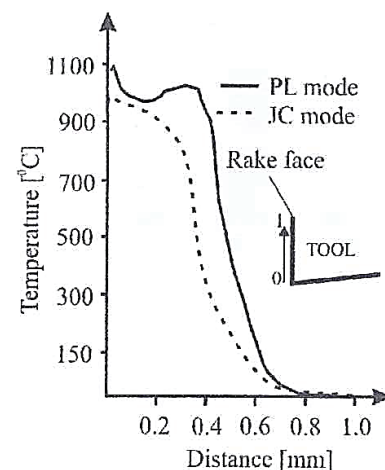

Figure 8 Change of the temperature along rake face of the tool in the contact cutting zone

Figs. 9a and 9b show the distribution of temperature in the tool, the workpiece and the metal chips for Power Law and the Johnson-Cook simulation model, after a continuous processing with length of 4,5 mm (Fig. 3). On both figures it is noticeable that most of the heat is transferred to the metal chips and then to the tool. The isothermal surfaces in the cutting zone shown in both models show that the maximal temperatures are localized near the cutting edge and the cutting edge of the tool. The isothermal surfaces also show that the temperatures on the rake face surface of the tool are reduced from the main cutting edge towards the end of the tool-chip contact.

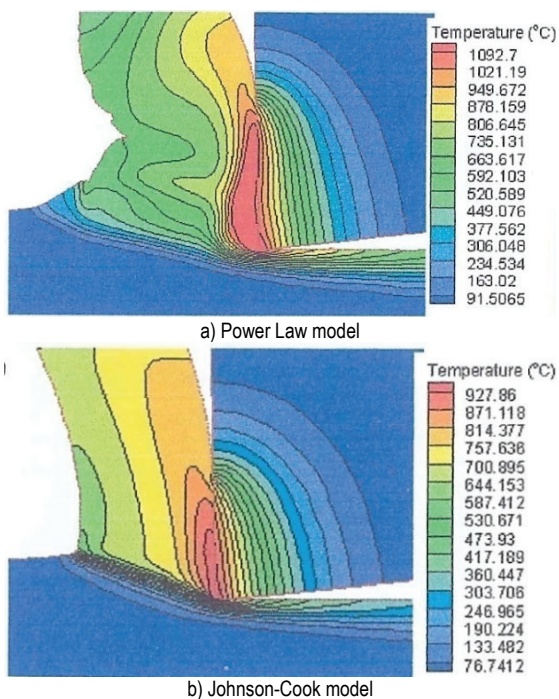

Figure 9 Distribution of temperature in the contact zone of cutting in continuous processing - $L_{oc} = 4,5$ mm ($v_c = 300$ m/min, $a_p = 1,1$ mm, $f = 0,1$ mm/o)

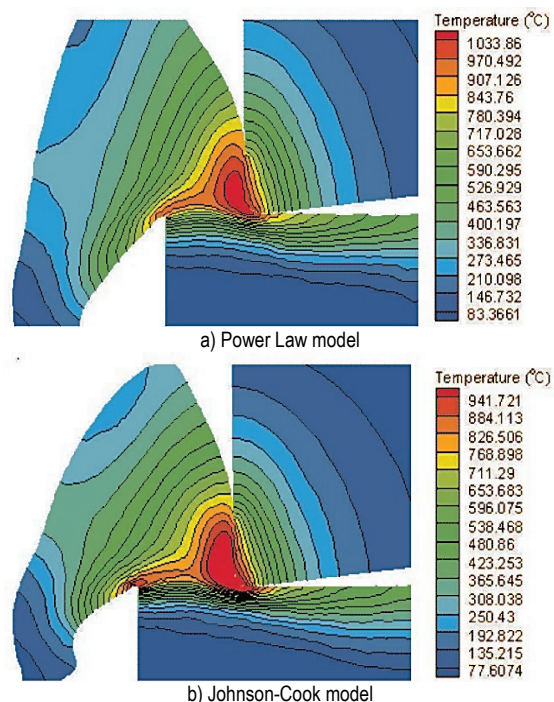

Figure 10 Distribution of temperature in the contact zone of cutting in discontinuous processing after $L = 2,9$ mm ($v_c = 300$ m/min, $a_p = 1,1$ mm, $f = 0,1$ mm/o)

Based on the identification of the temperature fields from the given figures, it is shown that the maximal temperatures 1093 °C (Power Law model) and 928 °C (Johnson-Cook model) on the rake face surface of the tool are located near the main cutting edge. This difference in temperature can be explained, inter alia, that the contact length of tool-chip in the Power Law model is much larger than the contact length of the Johnson-Cook model.

Figs. 10a and 10b shows the distribution of the temperature in the tool, workpiece and metal chips in discontinuous processing (turning of the longitudinal

grooves) for Power Law and Johnson-Cook simulation model, after the tool cut 2,9 mm in a given processing mode (Fig. 7). The maximal temperatures in the cutting zone for discontinuous processing are 1034 °C (Power Law model) and 942 °C (Johnson-Cook model) and they are slightly lower than the maximal temperatures in the continuous processing for the same cutting regime. However, the surface of the contact between the rake face surface of the tool and metal chips is considerably smaller and the overall heating of the tool is significantly less.

6 CONCLUSION

The tool abrasion to a great extent depends on the cutting temperature, that is, the amount of the heat generated in the tool during processing, which is why it is necessary to perform thermal simulations which include experimental research and modelling by finite element method.

In this paper two thermo-mechanical models of orthogonal cutting are presented for the description of the thermal phenomena in the forming of metal chips. Conducted simulations with the finite element method show the presence and localization of temperature fields in the cutting zone. The numerical values of the maximal temperatures are located near the main cutting edge, that is, in the initial part of the tool-chips contact.

Calculated temperature values on the tool, at the point where the thermocouple is installed, $TC1$ in the continuous processing vary depending on the simulation model used. The maximal temperature at this location calculated using the Power Law model corresponds to the experimentally measured value, while at the Johnson-Cook model it is considerably lower. These differences in the calculated temperatures for the used simulated models are primarily the consequence of the different length of the tool – chips contact. At the Johnson-Cook model, this length is significantly lower than the length of contact at the Power Law model. The calculated values of the maximal temperatures located near the main cutting edge do not show significant differences in the applied models (Figs. 6 and 7).

The calculated values of the maximum temperatures on the contact surface tool-chips are slightly less in the case of discontinuous processing than in the continuous processing, which is a consequence of the impact of the discontinuous cutting, where the tool (when not cutting) cools rapidly to a lower temperature.

The results of the analysis from this paper should expand the existing knowledge bases on research in this field, with the ultimate goal that numerical methods as much as possible replace complex and expensive experimental tests.

Acknowledgements

This paper is part of project TR35034 The research of modern non-conventional technologies application in manufacturing companies with the aim of increasing efficiency of use, product quality, reducing costs and saving energy and materials, funded by the Ministry of Education, Science and Technological Development of Republic of Serbia.

7 REFERENCES

- [1] Komanduri, R. & Hou, Z. B. (2001). A review of the experimental techniques for the measurement of heat and temperatures generated in some manufacturing processes and tribology, *Tribology International* 34, pp. 653-682, [https://doi.org/10.1016/S0301-679X\(01\)00068-8](https://doi.org/10.1016/S0301-679X(01)00068-8)
- [2] Augustine, U. & Olisaemeka, N. (2013). Thermal Aspect of Machining: Evaluation of Tool and Chip Temperature during Machining Process Using Numerical Method. *The International Journal of Engineering and Science (IJES)*, 2(4), 66-79.
- [3] Thakare, A. & Nordgren, A. (2015). Experimental Study and Modeling of Steady State Temperature Distributions in Coated Cemented Carbide Tools in Turning. *15th CIRP Conference on Modeling of Machining Operations, Procedia CIRP*, 31, 234-239. <https://doi.org/10.1016/j.procir.2015.03.024>
- [4] Chung-Shin, C. (2007). Prediction of the cutting temperatures of stainless steel with chamfered main cutting edge tools. *Journal of Materials Processing Technology*, 190(1-3), 332-341. <https://doi.org/10.1016/j.jmatprotec.2007.02.020>
- [5] Akbar, F., Mativenga, P. T., & Sheikh, M. A. An evaluation of heat partition in the high-speed turning of AISI/SAE 4140 steel with uncoated and TiN-coated tools. *Proc. IMechE*, 222, Part B: *J. Engineering Manufacture*, 759-771. <https://doi.org/10.1243/09544054JEM1072>
- [6] Pušavec, F., Stoić, A., & Kopač, J. (2009). The role of cryogenics in machining processes. *Technical Gazette*, 16(4), 3-10.
- [7] Nikolić, R., Lučić, M., Nedić, B., & Radovanović, M., (2018). Calculation of temperature fields during lathe machining with thermoelectric cooling by using the finite element method. *Thermal science*. <https://doi.org/10.2298/TSCI170518197N>
- [8] Yen, Y. C., Jain, A., Chigurupati, P., & Wu, W.-T. (2004). Computer Simulation of Orthogonal Cutting using a Tool with Multiple Coatings. *Machining science and technology*. <https://doi.org/10.1081/MST-200029230>
- [9] Bil, H., Kilic Engin, S., & Tekkaya, A. E. (2004). A comparison of orthogonal cutting data from experiments with three different finite elements models. *International Journal of Machine Tools & Manufacture*, 44, 933-944. <https://doi.org/10.1016/j.ijmactools.2004.01.016>
- [10] Alabi, A. G. F., Ajiboye, T. K., & Olusegun, H. D. (2012). Investigation of Cutting Temperatures Distribution in Machine Heat Treated Medium Carbon Steel on a Lathe. *The Pacific Journal of Science and Technology*. <https://doi.org/10.3923/jeasci.2012.113.122>
- [11] Kagnaya, T., Lazard, M., Lambert, L., Boher, C., & Cutard T. (2011). Temperature evolution in a WC-6% Co cutting tool during turning machining: experiment and finite element simulations. *WSEAS Transactions on Heat and Mass Transfer*, 6(3), 71-80.
- [12] Tanikić, D., Manić, M., & Devedžić, G. (2008). Modeling of the chip temperature by artificial intelligence methods. *Tehnička dijagnostika*, 4(2008), 3-11. Retrieved from <http://www.vbs.rs/scripts/cobiss?command=DISPLAY&base=COBIB&RID=184311052>
- [13] Borsos, B., Csörgő, A., Hidas, A., Kotnyek, B., Szabó, A., Kossa, A., & Stépán, G. (2017). Two-Dimensional Finite Element Analysis of Turning Processes. *Periodica Polytechnica Mechanical Engineering*, 61(1), 44-54. <https://doi.org/10.3311/PPme.9283>
- [14] Tahsin, T. Ö. & Xun, C. (2016). Chip Formation Mechanism Using Finite Element Simulation. *Strojniški vestnik - Journal of Mechanical Engineering*, 62(11), 636-646. <https://doi.org/10.5545/sv-jme.2016.2523>
- [15] Seyed Hamed, H., Sohi, G. J., & Denoga, C. (2017). Orthogonal Metal Cutting Simulation of Steel AISI 1045 via Smoothed Particle Hydrodynamic Method. *Proceedings of the World Congress on Engineering 2017, II*, 722-727. Retrieved from https://pdfs.semanticscholar.org/10ef/7481935392c7c631281f17a48a937fbf8920.pdf?_ga=2.71407379.1471653807.1573132618-1375561014.1558696505
- [16] Grzesik, W., Bartoszek, M., & Nieslony, P. (2005). Finite element modeling of temperature distribution in the cutting zone in turning processes with differently coated tools. *Journal of Materials Processing Technology*, 164-165, 1204-1211. <https://doi.org/10.1016/j.jmatprotec.2005.02.136>
- [17] Nieslony, P., Grzesik, W., Laskowski, P., & Habrat, W. (2013). FEM-Based Modelling of the Influence of Thermophysical Properties of Work and Cutting Tool Materials on the Process Performance. *14th CIRP Conference on Modeling of Machining Operations (CIRP CMMO)*, 3-8. <https://doi.org/10.1016/j.procir.2013.06.056>
- [18] Abed, F., Saffarini, M., Abdul - Latif A., & Voyiadjis G. Z. (2016). Flow Stress and Damage Behavior of C45 Steel Over a Range of Temperatures and Loading Rates. *Journal of Engineering Materials and Technology*, 139(2), 021012, 8. <https://doi.org/10.1115/1.4035488>
- [19] Zhang, Y., Outeiro, J. C., & Mabrouki, T. (2015). On the selection of Johnson-Cook constitutive model parameters for Ti-6Al-4V using three types of numerical models of orthogonal cutting. *15th CIRP Conference on Modelling of Machining Operations, Procedia CIRP* 31, 112-117. <https://doi.org/10.1016/j.procir.2015.03.052>
- [20] Jam, J. E. & Fard, V. N. (2011). A Novel Method to Determine Tool-Chip Thermal Contact Conductance in Machining. *International Journal of Engineering Science and Technology (IJEST)*, 3(12), 8491-8501.

Contact information:

Miroslav LUČIĆ

Technical College of Applied Studies,
Svetog Save 65, 32000 Čačak, Serbia
E-mail: miroslav.lucic@vstss.com

Bogdan NEDIĆ

(Corresponding author)
University of Kragujevac,
Faculty of Engineering,
ul. Sestre Janjić 6, 34000 Kragujevac, Serbia
E-mail: nedic@kg.ac.rs

Vlatko MARUŠIĆ

University of Slavonki Brod,
Mechanical Engineering Faculty in Slavonki Brod,
Trg Ivane Brlić Mažuranić 2,
35000 Slavonki Brod, Croatia
E-mail: vmarusic@sfsb.hr

Jelena BARALIĆ

University of Kragujevac,
Faculty of Technical Sciences Čačak,
Svetog Save 65, 32000 Čačak, Serbia
E-mail: jelena.baralic@ftn.kg.ac.rs

Andjelija MITROVIĆ

Technical College of Applied Studies,
Svetog Save 65, 32000 Čačak, Serbia
E-mail: andjelija.mitrovic@vstss.com