

Ivan VišićPro Integris, Split, Croatia, ivan.visic@prointegris.hr**Ivan Strnad**Pro Integris, Zagreb, Croatia, ivan.strnad@prointegris.hr**Tihomir Tonković**Veski, Zagreb, Croatia, tihomir.tonkovic@veski.hr

Real Time Load Angle Application for Synchronous Generator Protection Purposes

SUMMARY

The out-of-step protection function is one of the key functions in generator protection. This function detects the loss of generator synchronism, and when such a fault occurs, it is necessary to disconnect the generator from the rest of the system as soon as possible in order to avoid major damages. The algorithms used in the out-of-step protection functions are based on the measurements of generator impedances and they use the impedance vectors to check if all stability criteria are met. This paper describes a new approach to realizing the out-of-step generator protection function by using the direct load angle measurement. The idea behind applying the real time load angle measurement is to faster detect the loss of synchronism.

KEYWORDS

electrical load angle, synchronous generator, air gap, out of step generator protection.

INTRODUCTION

The generator protection device is one of the key components of every power plant. Its goal is to use input parameters (measurements and signals) and built-in algorithms to protect the generator from faults in auxiliary generator systems, faults in the grid and internal generator faults. Different functions or algorithms are used in the generator protection device to protect the generator from different types of faults. These algorithms are implemented in numeric protection relays that, in addition to carrying out the algorithms, gather and process input data and (depending on the algorithm results) act towards other systems to prevent generator damage. One of the functions with a major role in generator protection is the out-of-step protection function, which is currently implemented by assessing the generator stability based on the monotony, continuity and uniformity of impedance change [1],[2]. In certain operational situations (important power line outages, short circuits) in power systems, disturbances which can cause the loss of synchronism within the power system or between mutually connected systems can occur. If such a loss of synchronism is manifested, the asynchronous areas have to be isolated before the generator is damaged and other outages start occurring throughout the system. When the loss of generator synchronism occurs, high amplitude currents cause strains in generator windings as well as mechanical strains that can lead to generator and turbine damages [5]. Generator faults caused by such malfunctions usually bring significant financial costs manifested by expensive repairs and revenue loss due to production interruptions. The-

refore, it is important to identify the fault and shut the turbine and generator as soon as possible [3].

Considering the fact that the generator load angle is a value that specifically indicates the position of the generator operating point in relation to the border of stable operation, the possibility of using the load angle for generator protection purposes opens up [6]. In addition, load angle can be used in the following applications:

- maintenance of stability of power system through the action on generator excitation system,
- determination of real time generator capability chart,
- torsional dynamics of generator (analysis during power swing or electrical transient load),
- electro-mechanical resonance detection,
- measurement of losses (stator core and mechanical).

Although the load angle is a very reliable indicator of system stability, it is still insufficiently used in generator protection, and one of the reasons for this situation is the complexity of its direct measurement [4].

Taking into account the above mentioned, the paper describes the method used for real time measurements of the load angle of synchronous generator. The paper defines a new approach to using the load angle for

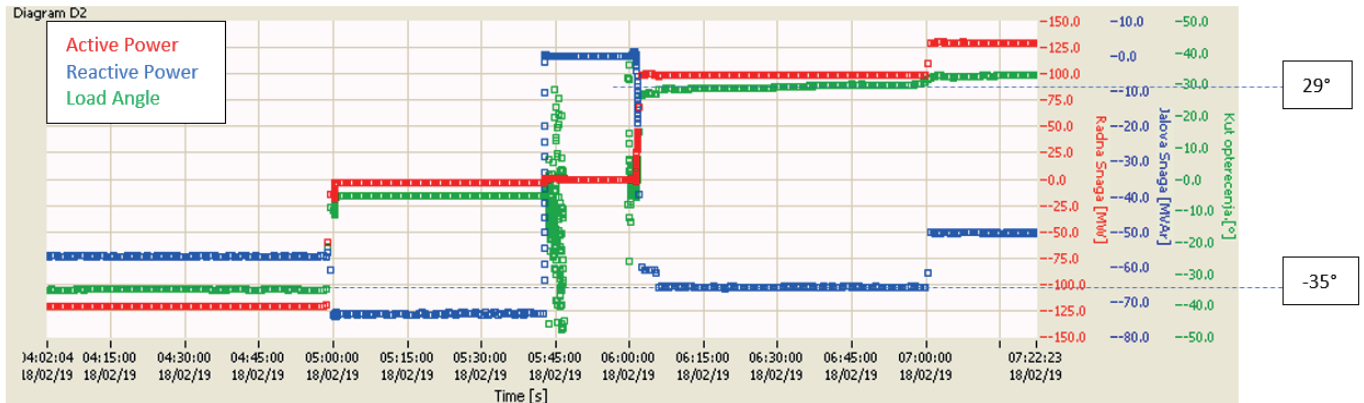

Fig. 1. Graphical representation that shows relation of rotor position, magnetic field and load angle

the generator out-of-step protection function. Additionally, the paper overviews the existing algorithms for synchronous generators' out-of-step protection function used in today's generator protection relays.

LOAD ANGLE MEASUREMENT

The electrical load angle (δ) is the angle between induced EMF and terminal voltage or the angle between rotor and stator magnetic fields. The magnetic field of a synchronous generator rotates at synchronous speed and induces a rotating magnetic field in a stator. These two fields are not completely aligned. The stator field lags behind the rotor field. This lagging is expressed in the load angle.

Fig. 1. shows the relation of rotor position, magnetic field and load angle. The generated power is directly proportional to the sine value of this angle.

The load angle is also a direct representative of magnetic field torsional stiffness inside the air gap as well as of generator stability in operation (e.g. out-of-step). On-line measurement of the load angle (static and dynamic) is of great importance when determining actual working parameters of a generator when combined with the on-line capability chart (P-Q chart). Load angle, if measured with fine resolution, can be used to determine losses of a generator. It is also a key parameter in understanding torsional dynamics of a generator where magnetic field stiffness influences dynamic response of the generator.

The load angle can be measured by either using the shaft encoder or air gap sensor placed inside the stator and the signal of terminal voltage on one phase (it doesn't matter which.). In our research, we use the air gap sensor method for measuring the load angle. The air gap sensor gives more stable and precise information on the rotor position compared to the

shaft encoder due to the small radius of the shaft encoder ring compared to the rotor radius. Consequently, the load angle calculation is more precise [7]- [10].

The air gap sensor measures the distance between the stator and rotor poles. It produces a signal whose frequency is twice the grid frequency and is a good representation of rotor position. Since the rotor position is in phase with induced EMF, it can be used to determine the value of the load angle together with a signal of terminal voltage.

Fig. 2. shows the measurement results and the relation between the terminal voltage signal and the air gap signal. As the load angle increases, the phase voltage lag behind the rotor position (induced EMF) also increases.

That method gives stable results as can be seen in Fig. 3. It shows the change of load angle in the synchronous condenser, pumping and generating regimes, with varying active and reactive power.

EXISTING METHODS OF DETECTING THE GENERATOR LOSS OF SYNCHRONISM

Over 30 years ago, the electrical centers of power systems were located in the transmission networks whose protections detected the losses of synchronism without the need of shutting down generators. Over the years, transmission networks got stronger, but so did the generator and block-transformer impedances. This resulted in moving electrical centers of the system all the way to block-transformers and generators, thus connecting the strains of the mentioned system components.

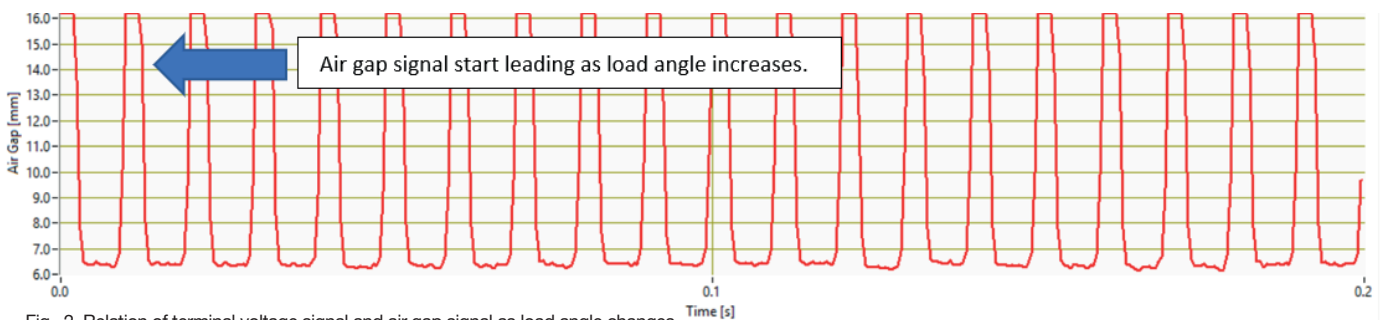

Fig. 2. Relation of terminal voltage signal and air gap signal as load angle changes

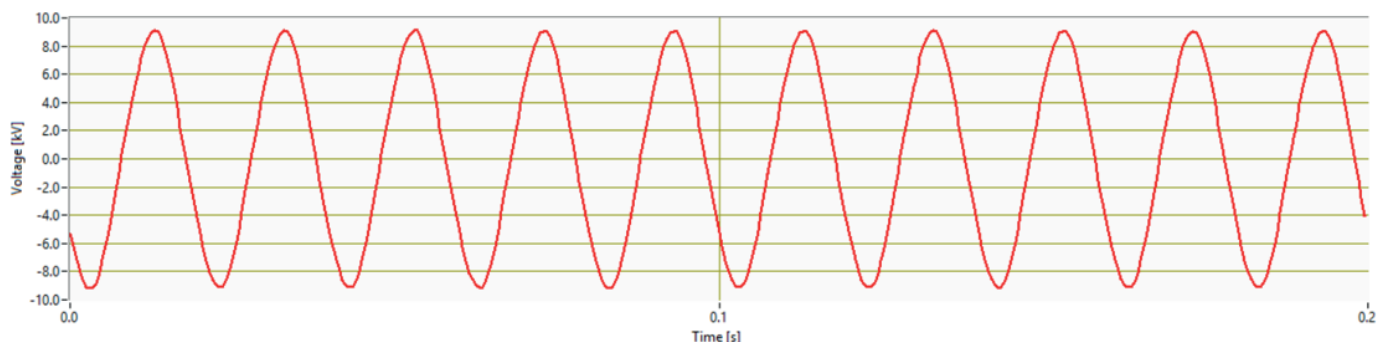

Fig. 3. Change of load angle as active and reactive power change in time

In such a system, the loss of synchronism will not be detected by network protections, and the need for the loss of generator synchronism protection emerged. The existing generator protections, such as the differential protection or the overcurrent protection will not work in such situations. [2] The loss of excitation detection function can detect some loss of synchronism, but will not work in all situations in the system. The term “loss of synchronism” is closely tied to the term “transient generator stability”. Transient stability deals with the issue of equalized processes through the phenomenon of attenuated oscillations of the angular rotor speed of synchronous machines, such as sudden load changes, changes of switching state and short circuits in the network. Transient stability is maintained if the oscillations are attenuated and the drive is returned to normal. In the case of transient stability, as well as static stability, there is a mutual dependence on the power transmitted and the generator load angle. In normal drive situations, this angle is constant and it depends on the load. In power swing situations, the angle oscillates, and when the loss of synchronism occurs, the angle can vary between 0 and 360 degrees [11],[12].

In the majority of modern numeric relays, the loss of synchronism function is realized through the measurement of impedance change in time. In the algorithms of this protection function, the passing of impedance vectors through the polygonal impedance characteristics is observed. The impedance is calculated from the positive sequence fundamental frequency components of the three voltages and currents. In Fig. 4. one typical out-of-step polygon is presented. It is described by impedances Z_a , Z_b , Z_c and Z_d . The polygon is symmetrical about its vertical axis. The origin of coordinate system represents the point of measurement of currents and voltages. Z_b is measured in reverse direction into the generator. In forward direction Z_c is measured into unit transformer and Z_d into power network. Depending of electrical centre of power swing, the impedance vector is moving through characteristic 1 or 2 [16]. When the condition for the loss of synchronism is fulfilled, that is, when the impedance vector passes through the polygonal characteristic, a counter is activated and the stimulus for the loss of synchronism protection is activated. After the set number of passes of the impedance vector through the polygonal characteristic is exhausted, the command to switch off the circuit breaker, excitation and turbine is activated [13],[14].

As set out above, the out-of-step protection functions are based on measuring the impedance and analyzing the history of the impedance phasor at a certain point, usually on the generator terminals. Additionally, the evaluation of the generator stability based on the criteria of monotony, continuity and uniformity impedance demands a certain time for detecting the loss of generator synchronism [15]. The next chapter will describe the concept of the out-of-step synchronism protection based on the direct load angle measurement.

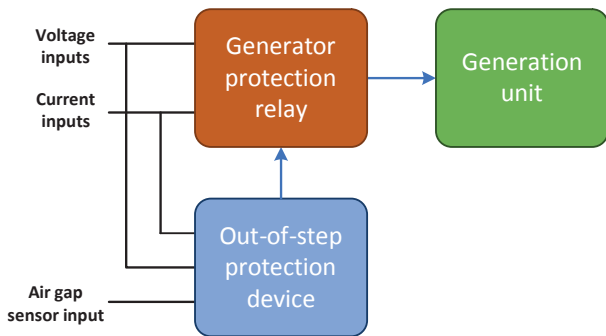

Fig. 4. Example of a characteristic of out-of-step polygon

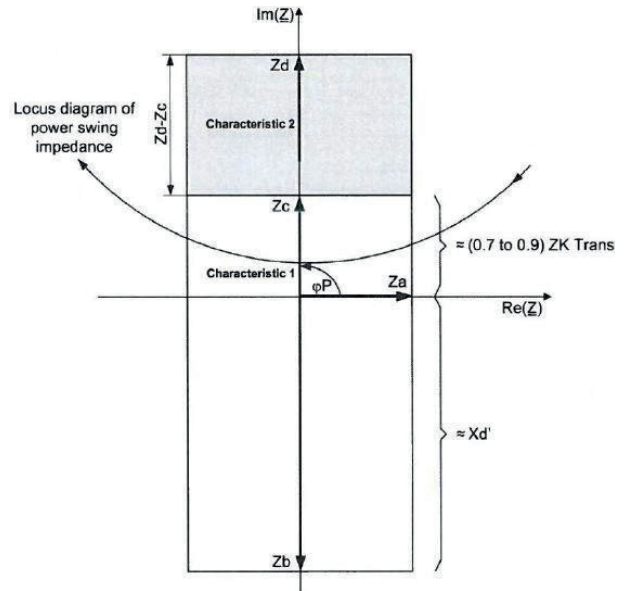

Fig. 5. Concept of the generator protection system with the separated out-of-step function

OUT OF STEP GENERATOR PROTECTION BASED ON THE DIRECT LOAD ANGLE MEASUREMENT

As previously mentioned, modern protections detect the loss of synchronism by measuring the impedance change, that is, by indirectly determining the generator load angle. On the other side, the load angle can be directly measured and such measurements are mostly used in the generator unit

monitoring systems [7]. In the monitoring systems, the load angle is calculated off-line on the basis of the collected measurements. For protection purposes, the load angle has to be calculated in real time and the calculations have to be performed with high accuracy and in short time intervals (every 20 ms). For easier understanding, the load angle calculation can be observed as the synchrophasor calculation. More details on the load angle measurements are given in Chapter 2. In our approach to the realization of the out-of-step generator protection function or the loss of synchronism by measuring the direct load angle, the air gap sensor method is used. The advantages of this method are also given in Chapter 2.

In the remainder of this chapter the approach or the idea behind the implementation of the out-of-step generator protection function by using the direct load angle measurement will be given. The main idea behind implementing this approach to the protection function is to develop a device that will encompass both the algorithm for measuring the load angle in real time and the algorithm for the out-of-step protection function. This device would be used alongside the usual generator protection relay and would detect the generator loss of synchronism faster than the standard relay protection function. Fig. 5. shows such a generator protection concept.

Unlike the calculation of the load angle for generator monitoring purposes, the measurement of the load angle in real time is much more complex for several reasons. To ensure the functionality of the protection algorithm, the load angle measurement has to be conducted every 20 to 40 ms.

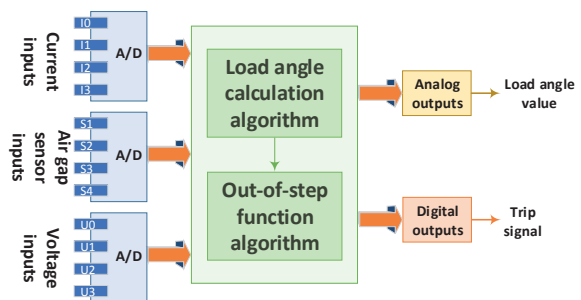

Fig. 6. The functional model of the development environment for testing the out-of-step protection function

Taking into account that the load angle is determined by measuring voltages and air gaps, it is very important to ensure the measurement precision, which on the other hand requires the processing of the measurement signal (voltage and air gap) to once again ensure the reliability and stability of the measurements. In applications where the processing time and calculation do not depend on the functionalities of the system (like monitoring) this does not represent a problem, but for generator protection purposes where only a short time interval is available for processing the signals and calculations and ensuring reliability, this is a challenge.

One of the main goals of this R&D project is to define the out-of-step generator protection function algorithm by measuring the direct load angle. In order to define and implement the protection algorithm in the development environment and to test it in the laboratory and in real conditions, a mathematical or simulation model for detecting the out-of-step generator protection has to be developed. The purpose of the simulation model is to enable the algorithm testing in certain operation states, and to determine, by using the simulation results, the algorithms' key parameters and its shortcomings. After defining the protection algorithm based on the conducted simulations and problem research, a functional model that will include all necessary functionalities of the device will be generated. The functional testing model for the out-of-step protection function is depicted in Fig. 6. The development environment is based on the National Instruments hardware and the LabVIEW simulation environment.

DIRECT LOAD ANGLE MEASUREMENT METHOD

To ensure the functionality of the out-of-step protection algorithm, a very precise and reliable measurement of the load angle has to be provided. The rest of this chapter will present the testing results and describe the method developed for measuring the direct load angle of the synchronous generator.

The implementation of the load angle measurement algorithm functionalities includes the air gap measurement, generator voltage measurement, and rotor position detection. The main goal was to develop a method for measuring the load angle in real time which will provide a stable calculation or measurement of the load angle every 20 ms, or after each period. Because the load angle is a value determined in the same way as the phasor, that is the smallest possible resolution in which it can be measured or determined. When compared to the commonly used method for measuring the load angle shown in Chapter 2, this method takes into consideration the rotor imperfection. The rotor imperfection can be explained as a geometrical imperfection. This directly influences the precision of the air gap measurement, and consequently the load angle value. The geometrical imperfection of the rotor is in fact structural in nature, and is present in every generator. The imperfection is specific to every rotor and it is constant in

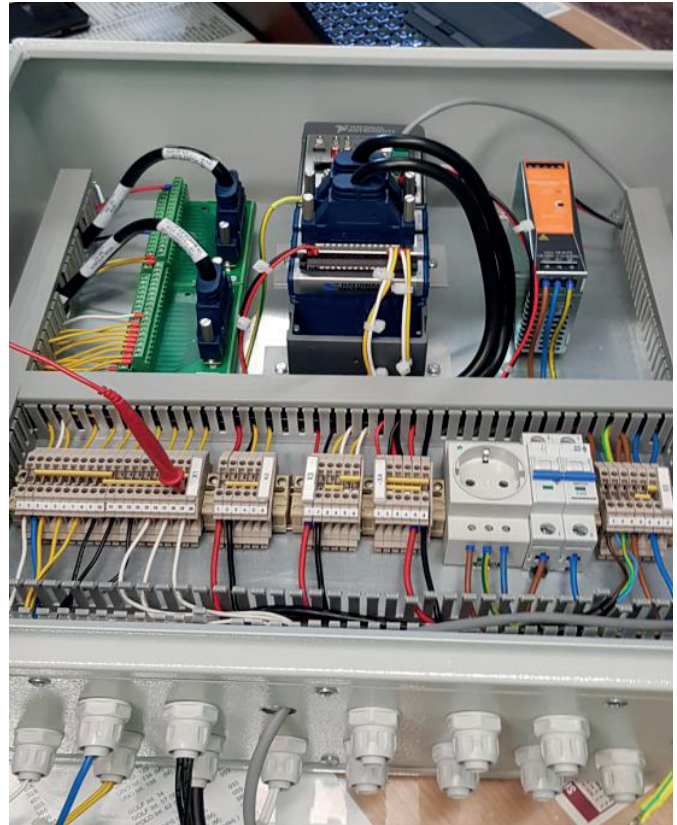

Fig. 9. Development environment for testing and direct load angle measurement

time, meaning it is possible to correct the air gap measurement for that specific imperfection. The characteristic of the deviation, which depends on the rotor position, has to be recorded in order to be applied in the direct load angle measurement algorithm. And to use this information in the algorithm, the rotor position first has to be determined. This is easily done by using the signal from the keyphasor sensor.

Fig. 7. shows the results of the direct load angle measurement without correcting the rotor geometrical imperfection, and Fig. 8. shows the re-

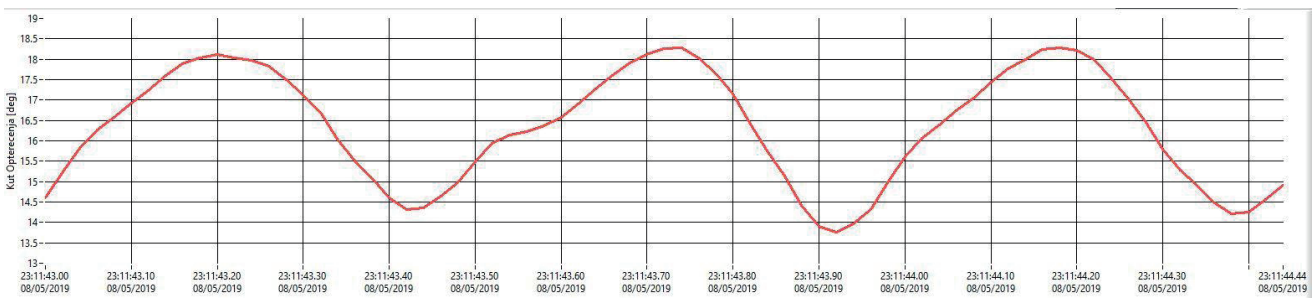

Fig. 7. Results of direct load angle measurement without geometrical imperfection correction

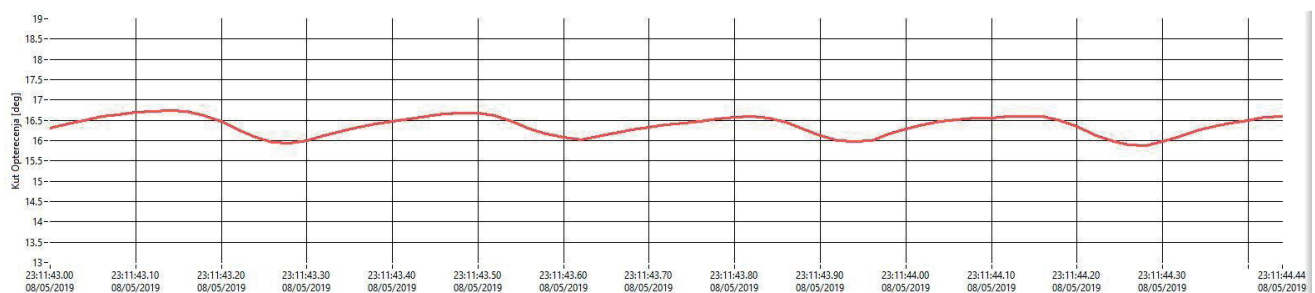

Fig. 8. Results of direct load angle measurement with geometrical imperfection correction

sults of the direct load angle measurement when the rotor geometrical imperfection is corrected. The results clearly show that correcting the rotor geometrical imperfection improves the stability and accuracy of the direct load angle measurement of the synchronous generator.

The results presented here were obtained by measuring the direct load angle on a real hydro generator. The development environment where the functionalities for data gathering and processing from sensors, as well as the algorithm for determining the direct load angle, are shown in Fig. 9.

CONCLUSION

The development of the electricity market, new regulations and the development of the power network on the one hand, and high expectations on electricity supply and availability on the other hand make the power system increasingly more complex. Due to the mentioned factors, periods in which the operation of power system is on the upper edge of its capacity occur more frequently. To make sure the power system stays stable in such situations, advanced technologies that allow intelligent system management have to be used. Taking into account that the load angle is a very reliable indicator of stability, it should be considered for application in the power system protection.

This paper sets out a new approach to realizing the out-of-step generator protection function by measuring the direct load angle which is currently under development in the Pro Integris company. The project itself is in the initial phase so only a limited array of results and technical details were given. In this phase of the project, the algorithm for the real time load angle measurement and the mathematical generator model for testing the out-of-step protection algorithm by measuring the direct load angle are being developed. The real time load angle measurement algorithm testing results performed on a real hydro generator show a very precise and stable load angle calculation within the highest possible resolution. The development of the protection algorithm is a further goal of this project. After the conducted testing and the optimization of both algorithms, the project will set out to develop a functional model that will encompass both the real time load angle measurement algorithm and the out-of-step protection algorithm.

By applying the proposed approach to the out-of-step generator protection, the goal is to achieve faster detection of the loss of synchronism from the detection speed of the currently commercially available solutions. Although this solution demands an additional device next to the existing protection relay, and thus increased generator protection system costs, the benefits this investment incurs through faster detections of the loss of synchronism should justify the cost, considering the substantial malfunctions such a fault can cause.

ACKNOWLEDGMENT

This project is co-financed by the Croatian Agency for SMEs, Innovations and Investments (HAMAG-BICRO), from the "Proof of Concept" program.

REFERENCES

- [1] S. Cheng, and M.S. Sachdev, "Out of Step Protection Using the Equal Area Criterion," Canadian Conference on Electrical and Computer Engineering, pp. 1488-1491, May 2005
- [2] D. Reimert, "Protective relaying for power generation systems," Taylor & Francis, 2006
- [3] J. Berdy, "Out of Step Protection for Generators," Electric Utility Systems Engineering Department, General Electric Company, New York
- [4] M. Mišković, M. Mirošević, and G. Ergec, "Load Angle Estimation of a Synchronous Generator Using Dynamical Neural Networks," *Energija*, vol. 58, No. 2, pp. 174-191, 2009
- [5] M. Abedini, M. Davarpanah, M. Sanaye-Pasand, S.M. Hashemi, and R. Irvani, "Generator Out-of-Step Prediction Based on Faster-Than Real Time Analysis: Concepts and Applications," *IEEE Transactions on Power Systems*, vol. 33, No. 4, 2018
- [6] M. Jadrić, and B. Frančić, "Dinamika električnih strojeva," *Graphis*, Zagreb, August 1997
- [7] M. Jadrić, B. Rajković, B. Terzić, M. Despalatović, Ž. Gladina, G. Orešković, B. Meško, and J. Macan, "Monitoring of Hydro Generator," *FESB*, Split, May 2004
- [8] G. Orešković, and B. Meško, "HE Dubrava - Oscilacije snage i vlastite elektromehaničke frekvencije titranja agregata A i B," *Veski and FER*, Zagreb, 2004
- [9] M. Despalatović, M. Jadrić, B. Terzić, and J. Macan, "On-Line Hydrogenerator Power Angle and Synchronous Reactances Determination Based on Air Gap Measurement," *IEEE PES Power Systems Conference and Exposition*, New York, vol. 2, pp. 753-758, 2004
- [10] M. Jadrić, M. Despalatović, B. Terzić, and B. Rajković, "Metodologija za identifikaciju parametara sinkronog hidrogeneratora temeljena na mjerenjima u sustavu monitoringa," *Automatika*, vol. 48, pp. 9-19, Zagreb, 2007
- [11] B. Filipović-Grčić, I. Ivanković, H. Bulat, and Z. Čerina, "Out of Step Generator Protection," 5. Savjetovanje HRO CIGRE, Cavtat, pp. 34-05, November 2001
- [12] B. Filipović-Grčić, I. Ivanković, and R. Vlačević, "Out of Step Protection in the Transmission Network," 6. Savjetovanje HRO CIGRE, Cavtat, pp. B5-06, November 2003
- [13] D.A. Tziouvaras, and D. Hou, "Out of step protection fundamentals and advancements," *SEL*, 2003
- [14] N. Kumar, D.R. Nagaraja, and H.P. Khincha, "A smart and adaptive scheme for generator out of step protection," *IEEE Innovative Smart Grid Technologies - Asia (ISGT ASIA)*, Bangkok, pp. 1-6, 2015
- [15] "SIPROTEC 5 Generator Protection 7UM85 Manual," *Siemens AG*, Nurnberg, 2018
- [16] SIPROTEC 4 Generator Protection 7UM62 Manual," *Siemens AG*, Nurnberg, 2017