

UDK 902  
ISSN 1330-0644  
VOL 37/2020.  
ZAGREB, 2020.

# Prilozi

Instituta za arheologiju u Zagrebu

Pril. Inst. arheol. Zagrebu, 37/2020  
Str./Pages 1–234, Zagreb, 2020.

Izdavač/*Publisher*  
INSTITUT ZA ARHEOLOGIJU  
INSTITUTE OF ARCHAEOLOGY

Adresa uredništva/*Address of the editor's office*  
Institut za arheologiju/*Institute of archaeology*  
HR–10000 Zagreb, Ulica Ljudevita Gaja 32  
Hrvatska/*Croatia*  
Telefon/Phone ++385/(0)1 61 50 250  
Fax ++385(0)1 60 55 806  
e-mail: urednistvo.prilozi@iarh.hr  
<http://www.iarh.hr>

Glavni i odgovorni urednik/*Editor in chief*  
Marko DIZDAR

Tehnički urednici/*Technical editors*  
Marko DIZDAR  
Katarina BOTIĆ

Uredništvo/*Editorial board*  
Marko DIZDAR, Snježana VRDOLJAK, Viktória KISS (Budapest, HUN) (prapovijest/*Prehistory*), Goranka LIPOVAC VRKLJAN, Ivan RADMAN-LIVAJA (antika/*Antiquities*), Tajana SEKELJ IVANČAN, Katarina Katja PREDOVNIK (Ljubljana, SLO), Natascha MEHLER (Wien, AUT), Juraj BELAJ, Tatjana TKALČEC (srednji vijek i novi vijek/*Middle Ages and Modern era*), Predrag NOVAKOVIĆ (Ljubljana, SLO) (metodologija/*Methodology*)

Izdavački savjet/*Editorial advisory board*  
Dunja GLOGOVIĆ (Zagreb), Ivor KARAVANIĆ (Zagreb), Laszlo KÓVACS (Budapest, HUN), Kornelija MINICHREITER (Zagreb), Aleksandar RUTTKAY (Nitra, SK), Ivančica SCHRUNK (Minneapolis, USA), Željko TOMIČIĆ (Zagreb), Ante UGLEŠIĆ (Zadar)

Prijevod na engleski/*English translation*  
Domagoj BUŽANIĆ, Kristina DESKAR, Dario HRUŠEVAR, Ana KONESTRA, Tamara LEVAK POTREBICA, Marko MARAS, Rory MACLEOD, Šime VRKIĆ, Mirna VUKOV

Lektura/*Language editor*  
Ivana MAJER, Marko DIZDAR (hrvatski jezik/*Croatian*)  
Marko MARAS (engleski jezik/*English*)

Korektura/*Proofreads*  
Katarina BOTIĆ

Grafičko oblikovanje/*Graphic design*  
Roko BOLANČA

Računalni slog/*Layout*  
Hrvoje JAMBREK

Tisak/*Printed by*  
Tiskara Zelina d.d., Sv. I. Zelina

Naklada/*Issued*  
400 primjeraka/400 copies

Prilozi Instituta za arheologiju u Zagrebu uključeni su u sljedeće indekse/  
Prilozi Instituta za arheologiju u Zagrebu are included in following indices:  
DYABOLA – Sachkatalog der Bibliothek – Römisch-Germanische Kommission des Deutschen Archaeologischen Instituts, Frankfurt a. Main  
Clarivate Analytics services – Web of Science Core Collection  
CNRS/INIST – Centre National de la Recherche Scientifique/L'Institut de l'Information Scientifique et Technique, Vandoeuvre-lès-Nancy  
EBSCO – Information services, Ipswich  
ERIH – European Reference Index for the Humanities, European Science Foundation, Strasbourg  
SciVerse Scopus – Elsevier, Amsterdam

E-izdanja. Publikacija je dostupna u digitalnom obliku i otvorenom pristupu na  
<https://hrcak.srce.hr/prilozi-iaz>  
*E-edition. The publication is available in digital and open access form at*  
<https://hrcak.srce.hr/prilozi-iaz?lang=en>

Ovaj rad licenciran je pod Creative Commons Attribution By 4.0 međunarodnom licencom /  
*This work is licenced under a Creative Commons Attribution By 4.0 International Licence*



## Sadržaj

## Contents

### Izvorni znanstveni radovi

### Original scientific papers

- 5 DOMAGOJ PERKIĆ  
MARIO NOVAK  
Tragovi prapovijesnih pokapanja ljudi u špiljama dubrovačkoga područja
- 37 ŠIME VRKIĆ  
NEDA KULENOVIĆ OČELIĆ  
Prilog poznavanju prapovijesnih gradina na donjem toku rijeke Zrmanje
- 73 ANA KONESTRA  
GORANKA LIPOVAC VRKLJAN  
BARTUL ŠILJEG  
The assortment of ceramic building materials from the pottery workshop of *Sextus Me(u)tillius Maximus* at Crikvenica (Croatia)
- 99 MIRJANA SANADER  
MIRNA VUKOV  
DOMAGOJ BUŽANIĆ  
Promjena perspektive o ranim rimskim migracijama na Sredozemlju. Slučaj istočnoga Jadrana
- 117 DARIO HRUŠEVAR  
KORALJKA BAKRAČ  
SLOBODAN MIKO  
NIKOLINA ILIJANIĆ  
OZREN HASAN  
MIRNA MAMIĆ  
TATJANA PULJAK  
ANITA VUC IĆ  
KATARINA HUSNJAK MALOVEC  
MARTINA WEBER  
BOŽENA MITIĆ  
Environmental history in Central Croatia for the last two millennia – vegetation, fire and hydrological changes under climate and human impact
- DOMAGOJ PERKIĆ  
MARIO NOVAK  
*Traces of prehistoric human burials in the caves of the Dubrovnik area*
- ŠIME VRKIĆ  
NEDA KULENOVIĆ OČELIĆ  
*A contribution to the study of the prehistoric hillforts in the lower course of the River Zrmanja*
- ANA KONESTRA  
GORANKA LIPOVAC VRKLJAN  
BARTUL ŠILJEG  
*Asortiman građevinske keramike iz keramičarske radionice Sexta Me(u)tillia Maxima u Crikvenici (Hrvatska)*
- MIRJANA SANADER  
MIRNA VUKOV  
DOMAGOJ BUŽANIĆ  
*A change of perspective on early Roman migrations in the Mediterranean. The case of the eastern Adriatic*
- DARIO HRUŠEVAR  
KORALJKA BAKRAČ  
SLOBODAN MIKO  
NIKOLINA ILIJANIĆ  
OZREN HASAN  
MIRNA MAMIĆ  
TATJANA PULJAK  
ANITA VUC IĆ  
KATARINA HUSNJAK MALOVEC  
MARTINA WEBER  
BOŽENA MITIĆ  
*Dvije tisuće godina okolišnih promjena na području središnje Hrvatske – vegetacija, požari i hidrologija utjecani klimatskim prilikama i ljudskim pritiskom*

165 SINIŠA KRZNAR  
TAMÁS HAJDU  
Kasnosrednjovjekovna i ranonovovjekovna  
populacija iz Ivankova, istočna Hrvatska: rezultati  
(bio)arheološke analize

SINIŠA KRZNAR  
TAMÁS HAJDU  
*Late medieval/early modern population from  
Ivankovo, eastern Croatia: the results of the  
(bio)archaeological analysis*

### Prethodno priopćenje

### Preliminary report

195 RENATA ŠOŠTARIĆ  
HRVOJE POTREBICA  
RENATA BONIĆ BABIĆ  
MARIJA MARTINOVIĆ  
TAMARA NOVAK  
Grobnice halštatskih kneževa na lokalitetu Kaptol –  
Čemernica: Arheobotanički nalazi iz tumula III i XI

RENATA ŠOŠTARIĆ  
HRVOJE POTREBICA  
RENATA BONIĆ BABIĆ  
MARIJA MARTINOVIĆ  
TAMARA NOVAK  
*Graves of Hallstatt Princes at Kaptol – Čemernica:  
Archaeobotanical Material from Tumuli III and XI*

211 IVANA OŽANIĆ ROGULJIĆ  
JERE DRPIĆ  
*Clavi coctiles iz Cibala (Vinkovci)*

IVANA OŽANIĆ ROGULJIĆ  
JERE DRPIĆ  
*Clavi coctiles from Cibalae (Vinkovci)*

227 UPUTE AUTORIMA

GUIDELINES FOR CONTRIBUTORS

# Clavi coctiles iz Cibala (Vinkovci)

## Clavi coctiles from Cibalae (Vinkovci)

Prethodno priopćenje  
Antička arheologija

*Preliminary communication*  
*Roman archaeology*

UDK/UDC 904:[728:697(497.5 Vinkovci)]652"

Primljeno/Received: 16. 02. 2020.  
Prihvaćeno/Accepted: 02. 09. 2020.

IVANA OŽANIĆ ROGULJIĆ  
JERE DRPIĆ  
Institut za arheologiju  
Ulica Ljudevita Gaja 32  
HR-10000 Zagreb  
iozanic@iarh.hr  
jdrpic@iarh.hr

*Manjim zaštitnim arheološkim istraživanjima koja su provedena 1990. godine u Vinkovcima na položaju Šokadija, otkriven je dio antičkoga stambenog objekta sa sustavom za grijanje. Detaljnom obradom arheološkoga materijala pronađenoga u ovome objektu indentificirano je, između ostalih nalaza, i više fragmenata šupljih kratkih keramičkih stožaca grublje izrade. Ovi predmeti se dovode u vezu s elementima jednoga specifičnog načina konstrukcije zidnoga dijela hypocausta, tj. zidnoga grijanja. Naime, riječ je o više fragmenata predmeta koji se nazivaju clavi coctiles, u hrvatskoj literaturi manje poznatih tipova keramičkih odstoynika korištenih u termalnim kompleksima diljem Rimskoga carstva.*

*Ključne riječi: clavi coctiles, terme, hypocaust, Vinkovci, Cibalae, kalem odstoynici, odstoynici, zidno grijanje*

*Minor rescue archaeological excavations were conducted in 1990 in the area of the town of Vinkovci, on the position Šokadija, a part of an ancient residential building where a heating system was discovered. Detailed processing of the archaeological material found in this building revealed, among other finds, several fragments of hollow short ceramic cones of coarser quality. These objects are related to the elements of a specific way of construction of the wall part of the hypocaust, i.e. wall heating. Namely, there are several fragments of objects called clavi coctiles, which in Croatian literature are described as lesser-known types of ceramic spacers, used in thermal complexes throughout the Roman Empire.*

*Key words: clavi coctiles, thermal baths, hypocaust, Vinkovci, Cibalae, spacer bobbins, spacers, wall heating*

### UVOD<sup>1</sup>

Zaštitnim arheološkim istraživanjima 1990. godine u centru antičkih Cibala otkrivena je poprilično uništena arhitektura uz jugoistočni dio foruma (sl. 1). Te godine provedena su istraživanja na položaju Šokadija koji se nalazi južno od zgrade Muzeja. Veličina iskopa bila je 22 x 20 m. Sonda je bila podijeljena na trake (kvadrante) od A – D. Tom prilikom su otkriveni devastirani ostaci objekta sa sustavom za grijanje. Pod na kojem su se nalazile suspenzure načinjen je od žbuke debljine 8 cm s podlogom od kamenih oblutaka vezanih žbukom (apsolutna visina ▼ 87,67 m). Opeke suspenzura rađene su u tri veličine (podloga 0,30 x 0,30 m i 0,30 x 0,40 m, stupići 0,20 x 0,20 m). U istočnome i sjevernome profilu iskopa na dubini 1,10 m registrirani su zidovi širine 0,90 m koji su pripadali mlađem objektu u

### INTRODUCTION<sup>1</sup>

Rescue archaeological excavation in 1990 in the centre of the ancient *Cibalae*, a rather ruined architecture, was discovered along the southeastern part of the forum (Fig. 1). That year, research was conducted at the position called Šokadija, which is located south of the Museum. The size of the excavation was 22 x 20 m. The trench was divided into quadrants A – D. On that occasion, the devastated remains of a building with a heating system were discovered. The floor on which the suspensions were placed was made of 8 cm thick plaster with a base of stone pebbles bound with plaster (absolute height ▼ 87.67). Suspension bricks were made in three sizes (base 0.30 x 0.30 m and 0.30 x 0.40 m, columns 0.20 x 0.20 m). In the eastern and northern profile of the excavation at a depth of 1.10 m, walls 0.90 m wide

<sup>1</sup> Ovaj rad je nastao u aktivnosti projekta *Life on the Roman road: communications, trade and identities on Roman roads in Croatia from 1<sup>st</sup> – 8<sup>th</sup> CE* (UIP-05-2017-9768) financiranome od Hrvatske zaklade za znanost.

<sup>1</sup> This paper was created as an activity of the project *Life on the Roman road: communications, trade and identities on Roman roads in Croatia from 1<sup>st</sup> – 8<sup>th</sup> CE* (UIP-05-2017-9768) funded by the Croatian Science Foundation.



Sl. 1 Smještaj lokaliteta Vinkovci – Šokadija s tlocrtom ostataka sustava za grijanje (Kartografska osnova preuzeta s: <https://geoportal.dgu.hr/>; tlocrt prema: Iskra-Janošić 2001: 70; obradio: J. Drpić)

Fig. 1 Sl. 1 Position of the Vinkovci – Šokadija site with a ground plan of the remains of the heating system (Cartographic basis taken from: <https://geoportal.dgu.hr/>; ground plan after: Iskra-Janošić 2001: 70; elaboration: J. Drpić)

potpunosti devastiranome prilikom rušenja zgrade prije arheoloških istraživanja (Iskra-Janošić 2001: 72; 2004: 175, sl. 11; Ožanić Roguljić 2005: 135–136; 2016).

Uzostatke *hypocausta* pronađenoga prilikom istraživanja, nađeni su i „neobični“ keramički predmeti manjih dimenzija stožastoga oblika te diskoidno proširenih krajeva. Zbog svoga specifičnog oblika i konteksta, prepoznati su kao fragmenti *clavi coctiles*, keramičkih elemenata korištenih u jednome od poznatih načina konstrukcije zidnoga grijanja u rimskim termama. Vjerojatno zbog svoje specifičnosti ovakav tip do sada nije bio prepoznat na hrvatskim antičkim lokalitetima. Stoga je cilj ovoga rada, kroz analogije, donijeti pregled funkcioniranja, osnovnu tipologiju te način izrade keramičkih odstoynika tipa *clavi coctiles* koji su pronađeni u Vinkovcima, tj. rimskim Cibalama, s manjim osvrtom i na ostale poznate rimske načine konstrukcije zidne šupljine unutar termalnih kompleksa zbog boljega razumijevanja problematike konstrukcije rimskoga zidnog grijanja.

## NAČINI KONSTRUKCIJE ZIDNOGA GRIJANJA U TERMAMA

Pretpostavlja se kako se rimsko zidno grijanje razvilo iz sustava dimnjaka kojima se odvodio zrak tj. plinovi i dim iz *hypocausta*. Također, sustav zidnoga grijanja štutio je prostorije termi od prevelike kondenzacije, a time i freske koje su se nalazile na unutarnjim zidovima (García-Entero 2001: 64). U rimskoj termalnoj arhitekturi do sada je prepoznato više načina konstrukcije zidnoga grijanja, točnije pet osnovnih načina ili sistema. Načini konstrukcije su određeni prema tipu keramičkih predmeta (odstoynici, šuplje cigle ili pločice s nogicama) koji su se u njih ugrađivali,<sup>2</sup> a koji su više ili manje uspješno iskorištavali potencijal vrućega zraka koji

2 Terminologija u svjetskim publikacijama nije ujednačena, pa ćemo u ovome radu predložiti hrvatske nazive.

were registered. That walls belonged to a younger building completely devastated during the demolition of the building before archaeological excavations (Iskra-Janošić 2001: 72; 2004: 175, Fig. 11; Ožanić-Roguljić 2005: 135–136; 2016).

In addition to the remains of the *hypocaust* found during the research, “unusual” ceramic objects, smaller in size, conical in shape, with trumpet-shaped ends, were also found. Due to their specific form and context, the finds were recognized as fragments of *clavi coctiles*. These ceramic elements were used in one of the ways of constructing wall heating in Roman baths. Probably due to its specificity, this type has not been recognized in Roman sites in Croatia. The aim of this paper through analogies is to provide an overview of the functioning, basic typology and method of making ceramic spacers *clavi coctiles* found in Vinkovci, i.e. Roman *Cibalae*. Also, short review of other known Roman ways of constructing a wall parish within thermal complexes will be included, for a better understanding of the wall heating construction diversity.

## WAYS OF CONSTRUCTION OF WALL HEATING IN THERMAL BATHS

It is assumed that Roman wall heating developed from a chimney system that removed air, i.e. gases and smoke from the hypocaust. Also, the wall heating system protected the thermal baths from excessive condensation, and thus the frescoes located on the interior walls (García-Entero 2001: 64). In Roman thermal architecture, several ways of constructing wall heating Roman baths have been recognized so far, more precisely five basic ways or systems. Construction methods were determined by the type of ceramic objects (spacers, hollow bricks or tiles with legs) that were built into them<sup>2</sup>, and which more or less

2 The terminology in world publications is not uniform, so in this paper we will propose Croatian terms.

je dolazio iz *hypocausta* (sl. 1) (Coll Monteagudo et al. 2019: 22; Del Giudice 2016: 18–26; Brodrribb 1987: 62–83; Craig 2013: 6; Nielsen 1990; Yegül 1992).

**1.** Tegule s nogicama (lat. *tegulae mammatae*) (sl. 2a) četvrtaste su keramičke pločice s četiri stožaste nogice. Pomoću njih se stvarala šupljina unutar duploga zida tako da bi se u nizu *tegulae mammatae* nogicama aplicirale na zid termi te fiksirale žbukom i čavlima. Tegule, tj. pločasti dio *tegulae mammatae* tako bi tvorilo oplatu unutarnjega zida prostorije termi na koju je još bila aplicirana žbuka. Tako slagane stvarale su šuplji prostor kojim je iz *hypocausta* cirkulirao topli zrak. Bile su jednostavnije za ugradnju, ali su bile manje energetski učinkovite u odnosu na tubule (Craig 2013: 6–8; Brodrribb 1987: 65; Koçyiğit 2007: 3).

**2.** Četvrtaste šuplje opeke (lat. *tubuli*) (sl. 2b) su, možemo reći, najpoznatiji i po Rimskome carstvu najrasprostranjeniji i najstariji keramički predmeti korišteni u konstrukciji zidnoga grijanja. Primjerci nađeni u Italiji datiraju u sredinu 1. st. Osim u konstrukciji zidnoga grijanja, mogli su biti korišteni i u konstrukciji dimnjaka za ispuh plinova te dima, ali i sustava kondenzacije vode u termalnim objektima (Garcia-Entero 2001: 64). Radi se o četvrtastoj šupljoj cigli koja je varirala veličinom, dok su na bočnim stranama bili otvori koji su omogućavali horizontalno i vertikalno strujanje zraka. Aplicirale su se pomoću žbuke izravno na unutarnji zid termi, s dijelom pune stijenke, dok se šuplji dio tubula nastavljao na sljedeći aplicirani i tako se u nizu tvori prostor kojim je prolazio topli zrak. Svojom su većom površinom ujedno zadržavale i više topline (Craig 2013).

**3.** Odstojnici u obliku keramičkoga čavla (engl. *spacer pins*) (sl. 2c) su keramički predmeti u obliku čavla ili klina koji su se užom stranom ugrađivali okomito na zid termalne prostorije pomoću žbuke, dok su na drugoj strani imali posebno oblikovane „glave“ sa žljebom u koje su se uglavljivali kutevi keramičkih pločica, unutarnje oplata zida prostorije. Ove keramičke pločice su se posebno oblikovale za ovakav tip odstoynika (Craig 2013: 8–9). Odstojnici u obliku keramičkoga čavla su varirali oblikom glave, ali i načinom izrade užega dijela kojim su se uglavljivali u oplatu zida termalne prostorije (Gamo 1987: 223–236). Prosječne su dužine od 20 do 25 cm (Farrington, Coulton 1990: 64; Koçyiğit 2007: 3).

**4.** Odstojnici u obliku kalema (lat. *clavi coctiles*; eng. *spacer bobbins*) (sl. 2d) šuplji su stožasti predmeti izrađivani na lončarskome kolu s proširenjem na jednome ili oba kraja, a najčešće u obliku kalema za namotavanje konopca, prosječno 7–10 cm dužine (Craig 2013: 9–10; Brodrribb 1987: 66–69; Bouet 1999: 67–83; Farrington, Coulton 1990: 57; Oulkeroglou 2017: 316).<sup>3</sup> Najčešće se tipološki razlikuju prema dužini, ali i načinu izrade proširenja za prijanjanje. Ovakvi odstoynici koristili su se u konstrukciji zidnoga grijanja čija je namjena pričvršćivanje tj. stvaranje šupljega

uspiješno iskoristiti potencijal topli zraka dolazeći iz hipokasta (Fig. 1) (Coll Monteagudo et al. 2019: 22; Del Giudice 2016: 18–26; Brodrribb 1987: 62–83; Craig 2013: 6; Nielsen, 1990; Yegül 1992).

**1.** Nipplated tiles (lat. *tegulae mammatae*) (Fig. 2a) are square ceramic tiles with four conical legs. They were used to create a cavity inside the double wall, so that in a series of *tegulae mammatae* they would be applied to the inner wall of the spa with their legs, and fixed with plaster and nails, and the tegula, i.e. the plate part of the *tegula mammata* plaster was still applied. Stacked in that manner, they created a hollow space, through which warm air circulated from the *hypocaustum*. They were easier to install but less energy efficient than tubules (Craig 2013: 6–8; Brodrribb 1987: 65; Koçyiğit 2007: 3).

**2.** Square hollow bricks (lat. *tubuli*) (Fig. 2b) are probably the most famous and most widespread and oldest ceramic objects used in the construction of wall heating in the Roman Empire. Specimens found in Italy date back to the middle of the 1<sup>st</sup> cent. AD. Apart from the construction of wall heating, they could also be used in the construction of chimneys for exhaust gases and smoke, but also water condensation systems in thermal facilities (Garcia-Entero 2001: 64). The bricks were square and hollow, which varied in size, and had openings on the sides that allowed horizontal and vertical air flow. They were applied by noise directly to the inner wall of the spa, with part of the full wall, while the hollow part of the *tubuli* continued to the next applied *tubulus* and thus in a row formed a space through which warm air passed, and at the same time retained more heat (Craig 2013).

**3.** Spacer pins (Fig. 2c) are ceramic objects in the shape of a nail or wedge, which were built vertically into the wall of the thermal room with plaster, while on the other side they had a special shaped “head” with a groove, into which the corners of the ceramic tiles were inserted, the inner formwork of the wall of the room. These ceramic tiles have been specially shaped for this type of spacer (Craig 2013: 8–9). Spacers in the shape of a ceramic nail vary in the shape of the head, but also in the way the narrower part is made, by which they are inserted into the wall of the room (Gamo 1987: 223–236). They are on average lengths of 20 to 25 cm (Farrington, Coulton 1990: 64; Koçyiğit 2007: 3).

**4.** Spacer bobbins (lat. *clavi coctiles*) (Fig. 2d) are hollow conical objects, made on a potter’s wheel with a trumpet extension at one or both ends, and most often in the form of a spool for winding a rope, an average of 7–10 cm in length (Craig 2013: 9–10; Brodrribb 1987: 66–69; Bouet 1999: 67–83; Farrington, Coulton 1990: 57; Oulkeroglou 2017: 316).<sup>3</sup> The most usually they differ typologically according to length, but also in the way of making trumpet ends. Such spacers were used in the construction of wall heating, the purpose of which is to fasten, i.e. create a hollow interspace between the wall and the stone or ceramic formwork of the

3 U publikacijama na engleskome jeziku se zbog oblika kalema za njih ustalio naziv *spacer bobbins*.

3 In English-language publications, the name spacer bobbins have become established for them due to the shape of the coil.

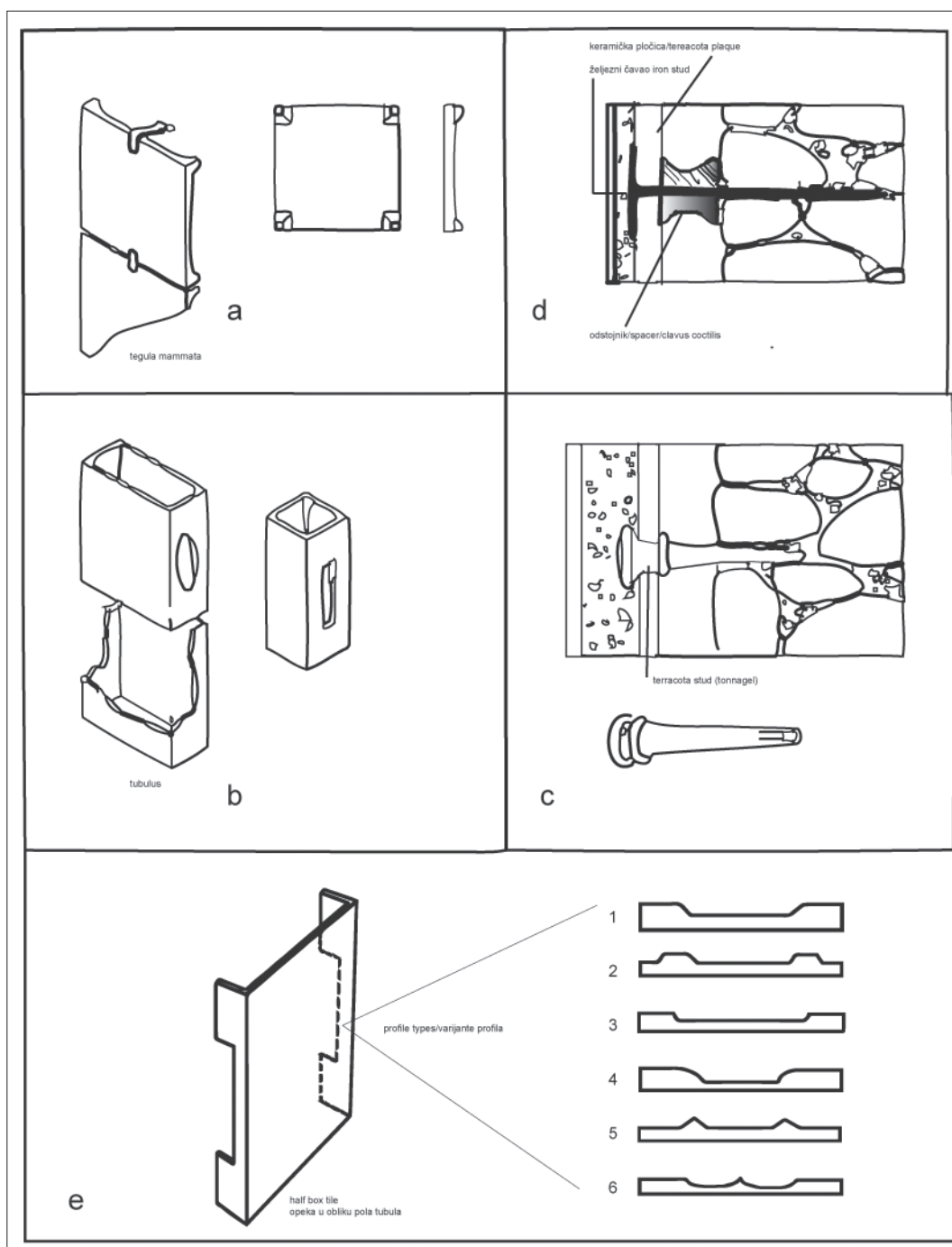

Sl. 2 Načini rimske konstrukcije zidnoga grijanja s različitim keramičkim elementima: a) tegula s nogicama (lat. *tegula mammata*); b) četvrtasta šuplja opeka (lat. *tubulus*); c) čavao odstonjik (eng. *spacer pin*); d) kalem odstonjik (lat. *clavus coctilis*); e) opeke u obliku pola tubula (eng. *half box tile*) (prema: Yegul 1992: 366, Fig. 455; obradili: I. Ožanić Roguljić, J. Drpić)

Fig. 2 Ways of Roman construction of wall heating with various ceramic elements: a) niplated tiles (lat. *tegula mammata*); b) square hollow bricks (lat. *tubulus*); c) spacer pin; d) spacer bobbins (lat. *clavus coctilis*); e) half box tile (after: Yegul 1992: 366, Fig. 455; elaboration: I. Ožanić Roguljić, J. Drpić)

međuprostora između zida i kamenih ili keramičkih oplata zidova termi. Fiksirali su se pomoću žbuke i pomoću većih čavla T-oblika koji su prolazili kroz šupljine unutar ovih predmeta i spajali zid s keramičkim pločicama oplata (sl. 3) na njihovim kutovima tj. spojevima. Dodatno su *clavi coctiles* bili učvršćeni ispunom od žbuke (Del Giudice 2016: 19–20; Craig 2013: 9–10; Brodribb 1987: 66–69; Bouet 1999:

thermal bath walls. They were fixed with plaster and larger T-shaped nails, which passed through the cavities inside these objects and connected the wall with ceramic formwork tiles (Fig. 3) at their corners, i.e. joints. Additionally, the *clavi coctiles* were reinforced with plaster filling (Del Giudice 2016: 19–20; Craig 2013: 9–10; Brodribb 1987: 66–69; Bouet 1999: 67–83; Farrington, Coulton 1990: 57; Oulkeroglou 2017: 316).



67–83; Farrington, Coulton 1990: 57; Oulkeroglou 2017: 316). Također, ovdje treba naglasiti i velike prednosti ovakvoga načina konstrukcije zidnoga grijanja zbog svoje praktičnosti i ekonomičnosti. Naime, kako su se relativno lako i brzo mogli proizvoditi u većim količinama, bili su dio jeftinijega načina konstrukcije. Zbog malih dimenzija i težine bili su lako prenosivi na gradilište, a zbog svojih proširenih završetaka jako su dobro nalijegali na obje zidne plohe. Čavli kojima su *clavi coctiles* bili učvršćeni prolazili su kroz njih te su tako bili u potpunosti zaštićeni od korozije, što je posljedično pozitivno utjecalo na dugovječnost čitave strukture ovakvoga načina konstrukcije zidnoga grijanja (Koçyiğit 2007: 4–5, 8).

5. Opeke u obliku pola tubula (engl. *half box tiles*) (sl. 2e) keramički su elementi u konstrukciji zidnoga grijanja koje su kombinirale izgled tubula i *tegulae mammatae*. Veličinom odgovaraju tubulu koji je uzdužno prerezan na pola te su mu izvedene četiri prirubnice (u raznim varijantama) koje su u istoj funkciji kao stožaste nogice kod *tegulae mammatae*. *Half box tiles* kao i *tegulae mammatae* bile su na zid učvršćivane pomoću metalnih spojnika ili čavala. Način konstrukcije zidnoga grijanja s ovim keramičkim elementima jednak je ranije opisanome kod *tegula mammata* (Craig 2013: 10).

Iako su teme o rimskoj termalnoj arhitekturi jako dobro zastupljene u svjetskoj literaturi, začudo jako je mali broj radova koji se bave specifičnostima predmeta koji su se koristili u konstrukciji zidnoga grijanja unutar termalne arhitekture. Tek je u zadnje vrijeme ova tema počela zaokupljati arheologe koji su tipološki razradili nalaze, tzv. *clavi coctiles* odstoynike, predmete koji su prepoznati u Cibalama.

### CLAVI COCTILES S LOKALITETA VINKOVCI – ŠOKADIJA

Ukupno 11 primjeraka *clavi coctiles* odstoynika pronađeno je u istraživanju termalnoga sklopa na položaju Šokadija u Vinkovcima (sl. 3). Svi primjerci su fragmentirani, tj. niti jedan primjerak nije u potpunosti sačuvan. Ono što je zajedničko svim primjercima je izrada na lončarskome kolu od gline s primjesom vapnenca. Vidljivi su kružni tragovi te nepravilne linije koje su tvorile narebnjenja na bočnim stranama odstoynika zbog boljega prijanjanja na podlogu. Također nema potpune uniformiranosti izrade, ali vidljivo je da su rađene serijski te se nije mnogo pazilo na izgled već samo na funkcionalnost. Može se također s velikom vjerojatnošću pretpostaviti da su proizvedeni u samim Cibalama koje su bile veliki produkcijski centar raznolike rimske keramike (Iskra-Janošić 1992: 208; 2001; Rapan Papeša 2011: 206–207; Sanader 2004: 29). Datacija izgradnje *hypocausta* s *clavi coctiles* odstoynicima na položaju Šokadija može se pretpostaviti u kraj 3. st., a korištenje objekta još i u 4. st. Deponirani keramički materijal s lokaliteta pretežno se datira od 1. do početka 3. st. i može se uzeti kao *terminus ante quem non* za izgradnju termalnoga objekta (Ožanić

Also, here we should emphasize the great advantages of this method of construction of wall heating due to its practicality and economy. Namely, as they could be produced relatively easily and quickly in larger quantities, they were part of a cheaper way of construction. Also due to their small size and weight, they were easily transferable to the construction site, and due to their trumpet-like finishes, they rested very well on both wall surfaces. The nails with which the *clavi coctiles* were fastened passed through them, and were thus completely protected from corrosion, which consequently had a positive effect on the longevity of the entire structure of this method of wall heating (Koçyiğit 2007: 4–5, 8).

5. Half box tiles (Fig. 2e) are ceramic elements in the construction of wall heating, which combined the appearance of *tubuli* and *tegula mammata*. The size corresponds to the tubule, which is cut lengthwise in half, and four flanges are made (in various variants), which are in the same function as the conical legs in *tegulae mammatae*. Half box tiles as well as *tegulae mammatae* were fixed to the wall using metal fasteners or nails. The method of construction of wall heating with these ceramic elements is the same as previously described with *tegula mammata* (Craig 2013: 10).

Although topics on Roman thermal architecture are generally very well represented in the world literature, surprisingly very few papers deal with the specifics of objects used in wall heating constructions within thermal architecture. Only recently has this topic begun to occupy archaeologists, who have typologically elaborated the findings, the so-called *clavi coctiles* spacers items recognized in *Cibalae*.

### CLAVI COCTILES FROM THE SITE VINKOVCI – ŠOKADIJA

A total of 11 of *clavi coctiles* spacers were found in the research of the thermal complex at the position Šokadija in Vinkovci (Fig. 3). All of them are fragmented, i.e. no specimen is fully preserved. What they all have in common is that they were made on a clay potter's wheel with an admixture of limestone. Circular traces are visible, as well as irregular lines, which formed ribs on the sides of the spacers due to better adhesion to the surface. There is also no complete uniformity of workmanship. Still, it is evident that they were made in series, and not much attention was paid to the appearance but only to the functionality. It can also be assumed with high probability that they were produced in *Cibalae* itself, which was a large production centre of various Roman ceramics (Iskra-Janošić 1992: 208; 2001; Rapan Papeša 2011: 206–207; Sanader 2004: 29). The dating of the construction of the *hypocaustum* with *clavi coctiles* spacers at the Šokadija site can be assumed at the end of the 3<sup>rd</sup> cent., and the use of the building in the 4<sup>th</sup> cent. The deposited ceramic material from the site mostly dates from the 1<sup>st</sup> to the beginning of the 3<sup>rd</sup> cent. It can be taken as a *terminus ante quem non* for the construction of a building with a *hypocaustum* (Ožanić Roguljić 2016: 27–31). It is very likely that the building was created after

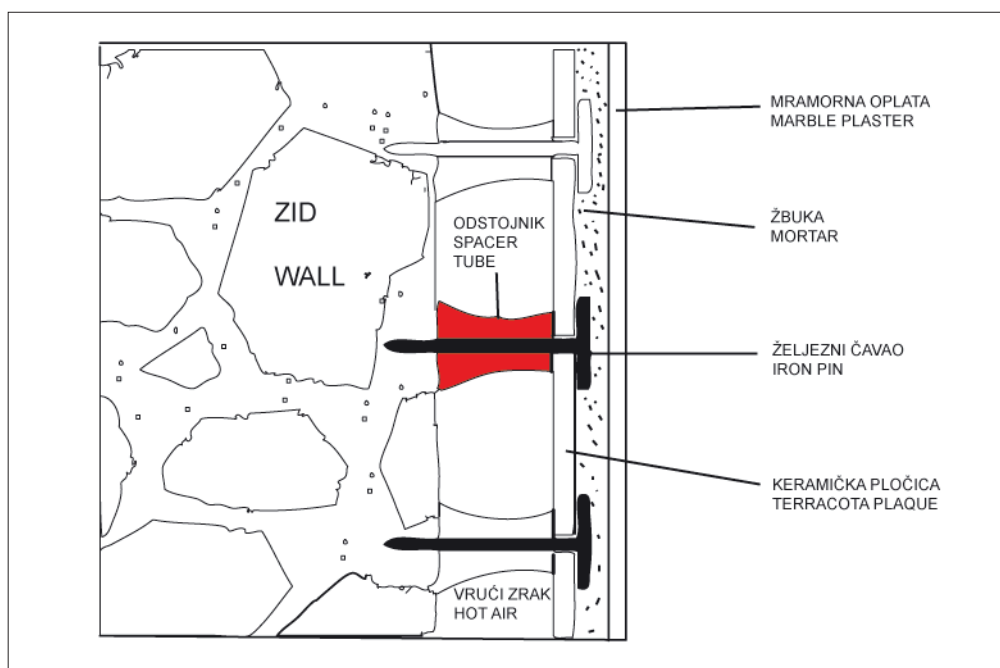

Sl. 3 Prikaz načina funkcioniranja strukture zidne šupljine izrađene pomoću odstojnika *clavi coctiles* (prema: Çelikbaş 2015: 73, Fig. III.5; obradila: I. Ožanić Roguljić)

Fig. 3 Demonstration of the functioning of the wall cavity structure made using spacers *clavi coctiles* (after: Çelikbaş 2015: 73, Fig. III.5; elaboration: I. Ožanić Roguljić)

Roguljić 2016: 27–31). Vrlo je vjerojatno objekt nastao nakon nivelacije terena kojom je negirana prethodna gradnja. Datacije *clavi coctiles* iz analogija potvrđuju ovu tezu. Ono što svakako valja spomenuti da su u istraživanjima na položaju Šokadija također pronađene i keramičke pločice koje bi se mogle interpretirati kao oplata unutarnjega zida termi. Nisu poznati nalazi specifičnih T-čavala većih dimenzija, jednoga od elemenata karakterističnih za ovaj način konstrukcije zidnoga grijanja. Također, zbog slabe sačuvanosti termalnoga kompleksa na položaju Šokadija, nije moguće znati dali su se u ovome slučaju *clavi coctiles* odstojnici upotrebljavali samo za izradu zidnoga grijanja ili šupljine dimnjaka, ili su korišteni za konstrukciji jednoga i drugoga.

Nešto ranije od vinkovačkih, u drugu polovicu 2. st. datirani su primjerci pronađeni u Sloveniji, na lokalitetu rimske ciglane Ilovica pri Vranskem (Lazar 2006: 33, sl. 64).<sup>4</sup> Odstojnici iz ove rimske radionice cigle su manjih dimenzija u odnosu na one iz Vinkovaca te rustičnije izvedbe, s manjom širinom šupljine unutar odstojnika, dok neki niti nemaju šupljinu.

Iako nisu interpretirani kao *clavi coctiles* već kao rimske vodovodne cijevi, primjerci iz Murse (Osijek) geografski su najbliža analogija (Pinterović 1978: kat. T. LVII). Objavljena su ukupno tri primjerka od kojih su dva u potpunosti očuvana, dok je jedan lagano fragmentiran pri završetku. Tipološki i načinom izrade u potpunosti odgovaraju primjercima

the levelling of the terrain, which negated the previous construction. The dating of *clavi coctiles* from analogies confirms this thesis. It is worth mentioning that the research of the Šokadija site also conducted ceramic tile finds, that could be interpreted as formwork for the inner wall of the spa. The findings of specific T nails of larger dimensions as one of the elements characteristic for this method of wall heating are not known. Also due to the poor preservation of the thermal complex at the Šokadija site, it is not possible to say for now whether these *clavi coctiles* spacers were used only to make wall heating or chimney cavities, or were used to construct both.

Specimens dating somewhat earlier than Vinkovci in the second half of the 2<sup>nd</sup> cent. were found in Slovenia, at the site of the Roman brickyard Ilovica near Vransko (Lazar 2006: 33, Fig. 64).<sup>4</sup> The spacers from this Roman brick workshop are smaller in size compared to those from Vinkovci and have a more rustic design, with a smaller width of the hole inside the spacers, while some do not even have a hole.

Although not interpreted as *clavi coctiles* but as Roman water pipes, specimens from *Mursa* (Osijek) are geographically the closest analogy (Pinterović 1978: cat. T. LVII). A total of three items that can be described as spacers were published, two of which are fully preserved, while one is slightly fragmented at one end. Typologically and in the way they are made, they completely correspond to the specimens from *Cibalae*. Unfortunately, for the specimens from *Mursa*, no dating or context of the findings

<sup>4</sup> Ova rimska ciglana proizvodila je materijal za vojsku nedalekog rimskog logora Ločica – *Legio II Italica* (Lazar 2006: 33, sl. 64).

<sup>4</sup> This Roman brickyard produced material for the army of the nearby Roman camp Ločica – *Legio II Italica* (Lazar 2006: 33, Fig. 64).



Sl. 4 Primjerci *clavi coctiles* pronađeni na položaju Šokadija u Vinkovicima (snimio i obradio: J. Drpić)

Fig. 4 Specimens of *clavi coctiles* found at the position Šokadija in Vinkovci (photo and elaboration: J. Drpić)

iz Cibala. Na žalost, za primjerke iz Murse ne spominju se datacija niti kontekst nalaza. Također, tri analogna primjerka pronađena su i u Sisku 2010. godine, točnije na lokalitetu Dunavski Lloyd. Na tome lokalitetu utvrđena je građevina koja se datira u 3. i 4. st. (Bačani et al. 2011: 91, 162, kat. br. 242–244). Međutim, predmeti također nisu prepoznati kao *clavi coctiles*. Nešto istočnije u današnjoj Srbiji, na lokalitetu rimskih termi u centru Čačka koje se datiraju u kraj 3. / početak 4. st., te u Viminaciju (*Viminacium*, Kostolac) i Medijani,<sup>5</sup> također je pronađen veći broj sačuvanih odstojnika tipa *clavi coctiles*. Primjerci iz Čačka su relativno manjih dimenzija u odnosu na ove iz Vinkovaca (Jeremić, Gojgić 2012: 41, kat. br. 9). Sjevernije, u današnjoj Rumunjskoj, ovi predmeti pronađeni su na dva lokaliteta (Barnea 1967: 242, sl. 15; Popilian 1971: 631, sl. 4), a u Grčkoj unutar više termi u gradu Dionu gdje se datiraju u 3.–4. st. te Korintu gdje se datiraju u kraj 6. i početak 7. st. (Biers 1985: 46, 49, 78, 98–99, sl. 4, T. 31: 113; Oulkeroglou 2017: 316–317; Sanders 1999: 473, Fig. 17. cat. no. 25–26).<sup>6</sup> Nalazi *clavi coctiles* iz Turske, posebice oni pronađeni u termama u Amoriumu i antičkome gradu Parionu na obali Mramornoga mora, jako

is mentioned. Also, three similar specimens were found in Sisak, more precisely at the Dunavski Lloyd site, in 2010. A building dating to the 3<sup>rd</sup> and 4<sup>th</sup> cent. (Bačani et al. 2011: 91, 162, cat. no. 242–244) was found at this site; however, the items were also not recognized as *clavi coctiles*. Somewhat further east in today's Serbia, at the site of the Roman baths in the centre of Čačak, which date to the end of the 3<sup>rd</sup> / beginning of the 4<sup>th</sup> cent., and in Viminacium (*Viminacium*, Kostolac) and Mediana,<sup>5</sup> a large number of preserved *clavi coctiles* spacers have also been found. Specimens from Čačak are relatively smaller in size compared to those from Vinkovci (Jeremić, Gojgić 2012: 41, cat. no. 9). Further north in present-day Romania, these objects have been found at two sites (Barnea 1967: 242, Fig. 15; Popilian 1971: 631, Fig. 4), and in Greece within several baths in the city of Dion where they date to the 3<sup>rd</sup>–4<sup>th</sup> cent. and Corinth where they date to the end of the 6<sup>th</sup> and the beginning of the 7<sup>th</sup> cent. (Biers 1985: 46, 49, 78, 98–99, Fig. 4, T. 31: 113; Oulkeroglou 2017: 316–317; Sanders 1999: 473, Fig. 17, cat. no. 25–26).<sup>6</sup> Finds of *clavi coctiles* from Turkey, especially those found in the thermal baths at the Amorium

5 Informacije su ustupili Angelina Raičković Savić i Ljubomir Jevtović.

6 Za nalaze iz grada Diona također je otkriveno da su se *clavi coctiles* koristili i u kombinaciji s tubulima.

5 The information was provided by Angelina Raičković Savić and Ljubomir Jevtović.

6 For finds from the city of Dion, it was also discovered that *clavi coctiles* were also used in combination with tubules.

su dobro obrađeni i klasificirani, a potvrđeno je njihovo korištenje i u 6.–7. st. (Koçyiğit 2006: 113–125; 2007: 2–9; Çelikbaş, Keleş 2015: 281–297; Çelikbaş 2015: 73). Još jedno područje s velikom koncentracijom nalaza *clavi coctiles* nalazi se na drugoj, zapadnoj strani Mediterana. Naime, u Španjolskoj je na više antičkih lokaliteta uz obalni pojas između gradova Barcelone, Valencije i Murcije pronađen veći broj ovih predmeta gdje se datiraju od sredine 1. st., a nastavili su se koristiti i u sljedeća četiri stoljeća (Coll Monteagudo et al. 2019: 18–31; Gamo 1987: 225–236; Garcia-Entero 2001: 59–78; Pavía Page 2018: 237–250). Također u dvije španjolske publikacije donosi se i njihova detaljnija tipološka razrada. R. S. Gamo tako zajedno, u istoj skupini predmeta, obrađuje odstojnike *clavi coctiles* i *spacer pins* te donosi podjelu na četiri tipa odstojnika, a sve *clavi coctiles* odstojnike smješta u jedan tip – tip 4a (Gamo 1987: 225–236). Novija istraživanja termi na lokalitetu Can Ferrerons također donose opširnu tipologiju *clavi coctiles* pronađenih na tome lokalitetu gdje su prepoznata tri osnovna tipa na ukupno 348 primjeraka (Coll Monteagudo et al. 2019: 18–31). Tipovi 2 i 3 su najbliža analogija vinkovačkim. Međutim, valja napomenuti da se niti na ovome lokalitetu ovi predmeti ne mogu sa sigurnošću datirati zbog nejasnoga arheološkog konteksta. Prisutnost *clavi coctiles* odstojnika potvrđena je i na više antičkih lokalitetima u Britaniji gdje se datiraju u 2. st. (Brodrigg 1987: 67–69; Craig 2013: 9).

## ZAKLJUČAK

Prema dosadašnjim saznanjima i stanju istraženosti, koje je još uvijek prilično skromno, možemo reći da su se u rimskoj termalnoj arhitekturi koristile razne varijante osnovnoga oblika *clavi coctiles* odstojnika. To se vjerojatno može pripisati masovnoj lokalnoj produkciji ovih predmeta koji opet ne odskakuju uvelike od osnovnoga oblika. Početak upotrebe *clavi coctiles* zabilježen je u Španjolskoj već od sredine 1. st., a prema dosadašnjim saznanjima najveću upotrebu ovi predmeti imali su od 3. st., i to na širem prostoru Rimskoga carstva, od Britanije na sjeveru, pa do zapadnoga i istočnoga Mediterana gdje se primjena ovih predmeta zadržala sve do 6.–7. st. Njihovu dugotrajnu primjenu vjerojatno treba pripisati većoj funkcionalnosti i jeftinijem načinu izrade u odnosu na druge načine konstrukcije zidnoga grijanja. Što se tiče samih vinkovačkih primjeraka, oni su najvjerojatnije produkti neke od brojnih lokalnih radionica keramike gdje je ovakve predmete bilo moguće proizvoditi u većim količinama, budući da ih zbog jednostavnosti izrade nije imalo nekoga smisla uvoziti iz udaljenijih krajeva. U prilog mogućoj lokalnoj proizvodnji ovih predmeta govori i činjenica da su u Sloveniji odstojnici *clavi coctiles* pronađeni na lokalitetu rimske ciglane koja je proizvodila materijal za obližnji rimski vojni logor Ločica – *Legio II Italica*. Iako je u Cibalama za sada poznato tek 11 poprilično fragmentiranih primjeraka, tipološki ih je bilo moguće smjestiti u tipove 2 i 3 prema tipologiji koja je razrađena za lokalitet Can Ferrerons u Kataloniji,

and the ancient city of Parion on the shores of the Sea of Marmara, are very well processed and classified. Their use has been confirmed in 6<sup>th</sup>–7<sup>th</sup> cent. (Koçyiğit 2006: 113–125; 2007: 2–9; Çelikbaş, Keleş 2015: 281–297; Çelikbaş 2015: 73). Another area with a high concentration of *clavi coctiles* is located on the other, western side of the Mediterranean. Namely, in Spain, in several ancient sites along the coastal belt between the cities of Barcelona, Valencia and Murcia, a large number of these objects were found, dating from the middle of the 1<sup>st</sup> cent., and continued to be used for the next four centuries (Coll Monteagudo et al. 2019: 18–31; Gamo 1987: 225–236; Garcia-Entero 2001: 59–78; Pavía Page 2018: 237–250). Also, in two Spanish publications, their more detailed typological elaboration is brought. R. S. Gamo thus, together, in the same group of cases, processes the spacers *clavi coctiles* and spacer pins, and brings the division into four types of spacers, and places all *clavi coctiles* spacers in one type or type 4a (Gamo 1987: 225–236). Recent research of the spa at the site of Can Ferrerons, also brings an extensive typology of *clavi coctiles* found at that site. Three basic types were identified, on a total of 348 specimens (Coll Monteagudo et al. 2019: 18–31). These types are typologically the closest analogy to the Vinkovci ones, which, according to that, typology could be placed in type 2 or 3. However, it should be noted that even in this locality, these objects cannot be dated with certainty. The presence of *clavi coctiles* spacers has also been confirmed at several ancient sites in Britain, where they date to the 2<sup>nd</sup> cent. (Brodrigg 1987: 67–69; Craig 2013: 9).

## CONCLUSION

According to previous knowledge and the state of research, which is still relatively modest, we can say that variants of the primary form of *clavi coctiles* spacers were used in Roman thermal architecture, which can be attributed to the probable local production of these objects. What can be said is that the beginning of the use of *clavi coctiles* was recorded in Spain as early as the middle of the 1<sup>st</sup> cent. and that according to current knowledge, they had the greatest use since the 3<sup>rd</sup> cent., in the Roman Empire; from Britain in the north, to the western and eastern Mediterranean, where the application of these objects remained until the 6<sup>th</sup>–7<sup>th</sup> cent. Widespread use should probably be attributed to their greater functionality and cheaper method of manufacture compared to most of other forms of construction of wall heating. As for the Vinkovci specimens themselves, they are most likely the products of one of the many local ceramics workshops, where such items could be produced in larger quantities. Due to the simplicity of production it made no sense to import them from more distant places. The fact that in Slovenia the *clavi coctiles* spacers were found at the site of a Roman brickyard that produced material for the nearby Roman military camp Ločica – *Legio II Italica* also speaks in favour of possible local production of these items. Although only 11 somewhat fragmented specimens are known in *Cibala* so far, they do not differ in shape from most other analogous items we brought in the paper. Typologically it was possible to place

a koji karakteristikama odgovaraju vinkovačkim. Prema analiziranome keramičkom materijalu, gradnju *hypocausta* s upotrebom *clavi coctiles* odstoynika na položaju Šokadija možemo datirati u 3. st., pri čemu je upotreba mogla potrajati i do 4. st.

Cilj ovoga rada bio je ukazati na specifičnost ovih predmeta, stvoriti osnovni okvir i dati smjernice za daljnja istraživanja, ponajprije u hrvatskoj arheologiji gdje su ovi predmeti do sada ostali neprepoznati. Analizom keramičkoga materijala iz Cibala te pregledom starijih objava Murse i Siscije, utvrđena je prisutnost *clavi coctiles* u urbanim sredinama u Panoniji unutar današnjih granica Hrvatske. Velika je vjerojatnost da su korišteni i na drugim lokalitetima te da je njihova upotreba puno šira, no zbog nedovoljnih analiza keramičkoga materijala općenito, a pogotovo građevinske keramike, ovim „neuglednim“ predmetima nije se pridavala veća pažnja. Stoga smatramo da prepoznavanje svih građevinskih konstrukcijskih struktura antičkih i kasnoantičkih građevina unutar urbanih sredina donosi kompletnu sliku o vještini zidara i uključenosti u opće prihvaćena i suvremena građevinska znanja, čemu i ovaj članak ide u prilog.

## KATALOG

### Kratice

Tip: prema obliku, latinski termin i predloženi hrvatski;

Opis: opis odstoynika;

G (glina): sastav gline opisan opservacijom (sa i bez primjesa, malo primjesa, krupne primjese); tvrdoća je podijeljena prema sljedećoj skali: mekana – može se zarezati noktom; tvrda – može se zarezati džepnim nožićem; jako tvrda – ne može se zarezati džepnim nožićem; opisana je boja gline šifrom prema Munsell 1998;

D (duljina): realna duljina odstoynika ili duljina sačuvanoga ulomka;

d (promjer) i dš (promjer šupljine) u cm;

DS (debljina stjenke) u cm;

Mjesto nalaza: sonda i dubina.

### T. 1

1. Tip: *clavus coctilis*, odstoynik u obliku kalema;  
Opis: ulomak polovice odstoynika koji se na sačuvanoj polovici postupno širi prema otvoru gdje je prstenasto zadebljan;  
G: tvrda, s primjesama, 5YR 7/4, 5YR 6/6;  
D: 7,1 cm;  
d: 5,2 cm;  
DS: 0,8 cm.
2. Tip: *clavus coctilis*, odstoynik u obliku kalema;  
Opis: ulomak središnjega dijela odstoynika koji se na jednoj strani postupno širi prema otvoru;  
G: tvrda, s primjesama, 5YR 6/6, 5YR 6/1;  
D: 6 cm;  
d: 3,3–3,7 cm;  
DS: 0,9 cm.

them in types 2 and 3 according to the typology developed for the site in Catalonia, Can Ferrerons, which correspond to the characteristics of Vinkovci. According to the analyzed ceramic material, the construction of the *hypocaustum* with the use of *clavi coctiles* at the Šokadija site can be dated to the 3<sup>rd</sup> cent. It could have been used until the 4<sup>th</sup> cent., which corresponds to the mentioned similar findings from Spain.

The aim of this paper was to point out the specificity of these objects, to create a basic framework and to provide guidelines for further research of these objects, primarily in Croatian archaeology, where these objects have mainly remained unrecognized so far. The analysis of ceramic material from *Cibalae* and the review of older publications of *Mursa* and *Siscia* established the presence of *clavi coctiles* in urban areas in Pannonia within today's borders of Croatia. It is very likely that they were used in other localities and that their use is much wider. Still, due to insufficient analysis of ceramic material in general, and especially building ceramics, these "inconspicuous" objects were not given much attention. Therefore, we believe that the recognition of all building structures of ancient and late antique buildings within urban areas brings a complete picture of the skill of masons and involvement in generally accepted and modern construction knowledge, to which this article is a contribution.

## CATALOGUE

### Abbreviations

Type: by form, Latin term and English term;

Description: description of the spacer;

C (Clay): the composition of clay described by observation (with and without impurities, few impurities, coarse impurities); hardness is divided according to next scale: soft – can be incised with a fingernail; hard – can be cut with a pocket knife; very hard – cannot be incised with a pocket knife; the color of the clay is described by the code according to Munsell 1998;

L (Length): the actual length of the spacer or the length of the preserved fragment;

d (Diameter) and CD (Cavity Diameter) in cm;

WT (Wall Thickness) in cm;

Location of the find: trench and depth.

### Pl. 1

1. Type: *clavus coctilis*, spool-shaped spacer;  
Description: Fragment of half of the spacer, which gradually expands on the preserved half towards the opening where the ring is thickened;  
C: hard, with inclusions, 5YR 7/4, 5YR 6/6;  
L: 7.1 cm;  
d: 5.2 cm;  
WT: 0.8 cm.
2. Type: *clavus coctilis*, spool-shaped spacer;  
Description: Fragment of the central part of the spacer, which gradually expands towards the opening on one side;  
C: hard, with inclusions, 5YR 6/6, 5YR 6/1;  
L: 6 cm;  
d: 3.3–3.7 cm;  
WT: 0.9 cm.

3. Tip: *clavus coctilis*, odstožnik u obliku kalema;  
Opis: ulomak središnjega dijela kalem odstožnika;  
G: tvrda, s primjesama, 5YR 7/3, 5YR 6/3;  
D: 7,1 cm;  
d: 3,3–3,6 cm.

## T. 2

1. Tip: *clavus coctilis*, odstožnik u obliku kalema;  
Opis: sačuvana polovice odstožnika, s prstenastim proširenjem uz rub;  
G: tvrda, s primjesama, 5YR 6/6, 5YR 6/4;  
D: 9 cm;  
d: 5 cm;  
DS: 0,7 cm;  
Mjesto nalaza: sonda B, 1,75–2 m.
2. Tip: *clavus coctilis*, odstožnik u obliku kalema;  
Opis: ulomak polovice odstožnika sa sačuvanim izraženim diskoidnim proširenjem uz rub;  
G: tvrda, s primjesama, 5YR 6/8, 5YR 6/6;  
D: 5,7 cm;  
d: 6,9–7 cm;  
DS: 0,8–0,9 cm;  
Mjesto nalaza: sonda B, 1,75–2 m.
3. Tip: *clavus coctilis*, odstožnik u obliku kalema?;  
Opis: ulomak pretpostavljenoga odstožnika, sačuvan manji dio s ravno izvučenim rubom; na vanjskoj stjenki je otisak u obliku slova V;  
G: tvrda, s primjesama, 5YR 6/3;  
D: 4 cm;  
d: 3 cm;  
DS: 0,7 cm;  
Mjesto nalaza: sonda B, 1,75–2 m.

## T. 3

1. Tip: *clavus coctilis*, odstožnik u obliku kalema;  
Opis: ulomak polovice odstožnika sa sačuvanim prstenastim proširenjem uz jedan rub;  
G: tvrda, s primjesama, 5YR 7/6, 5YR 6/2;  
D: 6,6 cm;  
d: 6 cm;  
DS: 0,9 cm;  
Mjesto nalaza: sonda C, 3–3,25 m.
2. Tip: *clavus coctilis*, odstožnik u obliku kalema?;  
Opis: ulomak pretpostavljenoga odstožnika; sačuvan manji dio koji se postupno širi prema otvoru;  
G: tvrda, s primjesama, 5YR 7/6, 5YR 6/1;  
D: 3,1 cm;  
d: 3,5 cm;  
DS: 1,1–1,2 cm;  
Mjesto nalaza: sonda B, 2–2,25 m.
3. Tip: *clavus coctilis*, odstožnik u obliku kalema;  
Opis: ulomak polovice odstožnika koji se na jednoj strani diskoidno širi prema otvoru;  
G: tvrda, s primjesama, 5YR 6/6, 5YR 6/1;  
D: 6,3 cm;  
d: 6,4 cm;  
DS: 0,9 cm;  
Mjesto nalaza: sonda B, 2,50–2,75 m.

3. Type: *clavus coctilis*, spool-shaped spacer;  
Description: Fragment of the central part of the spool spacer;  
C: hard, with inclusions, 5YR 7/3, 5YR 6/3;  
L: 7.1 cm;  
d: 3.3–3.6 cm.

## PI. 2

1. Type: *clavus coctilis*, spool-shaped spacer;  
Description: Preserved halves of spacers, with annular extension along the edge;  
C: hard, with inclusions, 5YR 6/6, 5YR 6/4;  
L: 9 cm;  
d: 5 cm;  
WT: 0.7 cm;  
Location: Trench B, 1.75–2 m.
2. Type: *clavus coctilis*, spool-shaped spacer;  
Description: Fragment of half of the spacer with preserved pronounced discoid extension along the edge;  
C: hard, with inclusions, 5YR 6/8, 5YR 6/6;  
L: 5.7 cm;  
d: 6.9–7 cm;  
WT: 0.8–0.9 cm;  
Location: Trench B, 1.75–2 m.
3. Type: *clavus coctilis*, spool-shaped spacer?;  
Description: Fragment of a presumed spacer, preserved small part with straight edge; there is a V-shaped imprint on the outer wall;  
C: hard, with inclusions, 5YR 6/3;  
L: 4 cm;  
d: 3 cm;  
WT: 0.7 cm;  
Location: Trench B, 1.75–2 m.

## PI. 3

1. Type: *clavus coctilis*, spool-shaped spacer;  
Description: Fragment of half of the spacer with preserved ring extension along one edge;  
C: hard, with inclusions, 5YR 7/6, 5YR 6/2;  
L: 6.6 cm;  
d: 6 cm;  
WT: 0.9 cm;  
Location: Trench C, 3–3.25 m.
2. Type: *clavus coctilis*, spool-shaped spacer?;  
Description: Fragment of a presumed spacer, a small part preserved that gradually widens towards the opening.  
C: hard, with inclusions, 5YR 7/6, 5YR 6/1;  
L: 3.1 cm;  
d: 3.5 cm;  
WT: 1.1–1.2 cm;  
Location: Trench B, 2–2.25 m.
3. Type: *clavus coctilis*, spool-shaped spacer;  
Description: Fragment of half of the spacer, which on one side spreads tubularly towards the opening;  
C: hard, with inclusions, 5YR 6/6, 5YR 6/1;  
L: 6.3 cm;  
d: 6.4 cm;  
WT: 0.9 cm;  
Location: Trench B, 2.50–2.75 m.

#### T. 4

1. Tip: *clavus coctilis*, odstojnik u obliku kalema,  
Opis: ulomak rubnoga dijela odstojnika koji se na jednoj strani diskoidno širi prema otvoru;  
G: tvrda, s primjesama, 5YR 6/6, 5YR 6/1;  
D: 7,4 cm;  
d: 6,2 cm;  
DS: 0,9 cm;  
Mjesto nalaza: sonda B, 2,50–2,75 m.
2. Tip: *clavus coctilis*, odstojnik u obliku kalema;  
Opis: ulomak polovice odstojnika koji se na jednoj strani postupno širi prema otvoru gdje je lagano zadebljan; na vanjskoj stjenki dobro vidljiva paralelna rebra, posljedica izrade na lončarskome kolu;  
G: tvrda, s primjesama, 5YR 7/6, 5YR 6/2;  
D: 7,3 cm;  
d: 5,6 cm;  
DS: 0,7–0,9 cm;  
Mjesto nalaza: sonda B, 2,50–2,75 m.

Prijevod / Translation  
Rory Macleod

Lektura / Proofreading  
Marko Maras

#### Pl. 4

1. Type: *clavus coctilis*, spool-shaped spacer;  
Description: Fragment of the edge part of the spacer, which spreads tubularly towards the opening on one side;  
C: hard, with inclusions, 5YR 6/6, 5YR 6/1;  
L: 7.4 cm;  
d: 6.2 cm;  
WT: 0.9 cm;  
Location: Trench B, 2.50–2.75 m.
2. Type: *clavus coctilis*, spool-shaped spacer;  
Description: Fragment of half of the spacer, which on one side gradually widens towards the opening, where it is slightly thickened; parallel ribs are clearly visible on the outer wall, a consequence of the construction on the potter's wheel;  
C: hard, with inclusions, 5YR 7/6, 5YR 6/2;  
L: 7.3 cm;  
d: 5.6 cm;  
WT: 0.7–0.9 cm;  
Location: Trench B, 2.50–2.75 m.

## LITERATURA / BIBLIOGRAPHY

- Adam, J. P. 1994, *Roman building. Materials and techniques*, Routledge, London – New York.
- Baćani, I., Gospodinović, S., Škrkulja, R., Tomaš Barišić, T. 2011, *Zaštitna arheološka istraživanja Gradskog muzeja Sisak 2000–2010*, katalog izložbe, Gradski muzej Sisak, Sisak.
- Barnea, I. 1967, Les Thermes de Dinogetia, *Dacia*, N.S. Vol. 11, 225–252.
- Biers, J. C. 1985, *Corinth, Vol. XVII, The Great Bath on the Lechaion Road*, The American School of Classical Studies at Athens, Princeton.
- Bouet, A. 1999, *Les matériaux de construction en terre dans les thermes de la Gaule Narbonnaise*, Ausonius Éditions, Paris.
- Brodribb, G. 1987, *Roman Brick and Tile*, Alan Sutton Publishing, Gloucester.
- Çelikbaş, E. 2015, Slope Structure, in: C. Başarat, *The flourishing city of ancient troad: Parion, surveys, excavation and restoration works carried out Between 1997-2009*, Ege Yayınları, Istanbul, 67–76.
- Çelikbaş, E., Keleş V. 2015, Wall heating systems in Roman architecture and 'spacer tubes' found in the Parion Slope structure, *Talanta*, Vol. XLVI–XLVII/2014–2015, 281–297.
- Coll Monteagudo, R., Prevosti, M., Bagà Pascual, J. 2019, Elements d'escalfament i de drenatge del *balneum* de l'edifici octagonal de Can Ferrerons (Premia de Mar, El Maresme): *tubuli latericii i clavi coctiles*, *Trobada d'Entitats de Recerca Local i Comarcal del Maresme*, XII(2018), 18–31.
- Craig, A. H. 2013, *Tubuli and their use in Roman Arabia, with a focus on Humayma (Ancient Haurra)*, Unpublished MA thesis, University of Victoria, Victoria.
- Del Giudice, F. 2016, *I materiali fittili speciali nell'edilizia termale di età romana*, Unpublished MA thesis, Università di Pisa, Pisa.
- Farrington, A., Coulton J. J. 1990, Terracotta spacer pins in Lycian bath buildings, *Anatolian Studies*, Vol. 40, 55–67. doi: <https://doi.org/10.2307/3642796>
- Gamo, R. S. 1987, Algunos materiales romanos utilizados en la construcción de concameraciones, *Oretum*, Vol. III, 223–236.
- García-Entero, V. 2001, Reflexiones en torno a las termes de las villae hispanorromanas: el material constructivo: cronología y dispersión geográfica, in: *Ocio y espectáculo en la antigüedad tardía. Actas del II Encuentro Hispania en la Antigüedad Tardía, Alcalá de Henares 15 al 17 de octubre de 1997*, García Moreno L., Rascón Marqués S. (eds.), Acta Antiqua Complutensia II, Universidad de Alcalá, Alcalá de Henares, 59–78.
- Iskra-Janošić, I. 1992, Građevinski materijali i njihova upotreba u Cibalama, *Opuscula archaeologica*, Vol. 16, 207–218.
- Iskra-Janošić, I. 2001, *Urbanizacija Cibala i razvoj keramičarskih središta*, Hrvatska akademija znanosti i umjetnosti, Centar za znanstveni rad u Vinkovcima, Vinkovci.
- Iskra-Janošić, I. 2004, Colonia Aurelia Cibalae, Entwicklung der Stadt, in: *The Autonomous Town of Noricum and Pannonia. Pannonia II, Šašel Kos M., Scherrer P. (eds.)*, Situla 42, Narodni muzej Slovenije, Ljubljana, 169–195.
- Jeremić, G., Gojgić, A. 2012, *Rimske terme u Čačku*, Narodni muzej Čačak, Čačak.
- Koçyiğit, O. 2006, Terracotta Spacers from the Bathhouse at Amorium, *Anatolian Studies*, Vol. 56, 113–125. doi: <https://doi.org/10.1017/S006615460000079X>
- Koçyiğit, O. 2007, The Role of the Terracotta Spacers in the Heating System of the Amorium Bathhouse, in: *Proceedings of the First International Symposium on Late Antique, Byzantine, Seljuk and Ottoman Pottery and Tiles in the Archaeological Context*, Canakkale 1–3 June 2005, Böhlendorf-Arslan B., Uysal A. O., Witte-Orr J. (eds.), Ege Yayınları, Istanbul, 309–318.
- Lazar, I. 2006, *Ilovlca pri Vranskem*, Arheologija na avtocestah Slovenije 1, Zavod za varstvo kulturne dediščine Slovenije, Ljubljana.
- Money, J. H. 1974, Exhibits at Ballots, 1. Clay spacers from the Romano-British Bath-house at Garden Hill, Hartfield, Sussex, *Antiquaries Journal*, Vol. 54(2), 278–280.
- Munsell 1998, *Munsell Soil Color Charts*, Munsell Color Company, New York.
- Nielsen, I. 1990, *Thermae et Balnea: The Architecture and Cultural History of Roman Public Baths*, Aarhus University Press, Aarhus.
- Oulkeroglou, A. 2017, Public baths in Roman Dion (Colonia Iulia Augusta Diensis), *Journal of Greek Archaeology*, Vol. 2, 287–324.
- Ožanić, I. 2005, Tipovi amfora iz Cibala, *Vjesnik za arheologiju i povijest dalmatinsku*, Vol. 98, 133–149.
- Ožanić Roguljić, I. 2016, *Tipologija rimske keramike iz Vinkovaca*, Monographiae Instituti Archaeologici 10, Institut za arheologiju, Zagreb.
- Pavía Page, M. 2018, Thermae públicas y balnea domésticos en la ciudad romana de Carthago Nova, *SPAL: revista de prehistoria y arqueología*, Vol. 27(1), 237–253. doi: <https://doi.org/10.12795/spal.2018i27.09>
- Pinterović, D. 1978, *Mursa i njeno područje u antičko doba*, Centar za znanstveni rad Jugoslavenske akademije znanosti i umjetnosti Osijek, Osijek.
- Popilian, G. 1971, Thermele de la Slăveni, *Apulum*, Vol. IX, 626–641.
- Rapan Papeša, A. 2011, Topografija Cibala u kasnoj antici, *Opuscula archaeologica*, Vol. 35, 189–224.
- Sanader, M. 2004, *Antički gradovi u Hrvatskoj*, Školska knjiga, Zagreb.
- Sanders, G. D. R. 1999, A Late Roman Bath at Corinth: Excavations in the Panayia Field, 1995–1996, *Hesperia*, Vol. 68(4), 441–480.
- Yegül, F. 1992, *Baths and Bathing in Classical Antiquity*, MIT Press, Cambridge.



T. 1

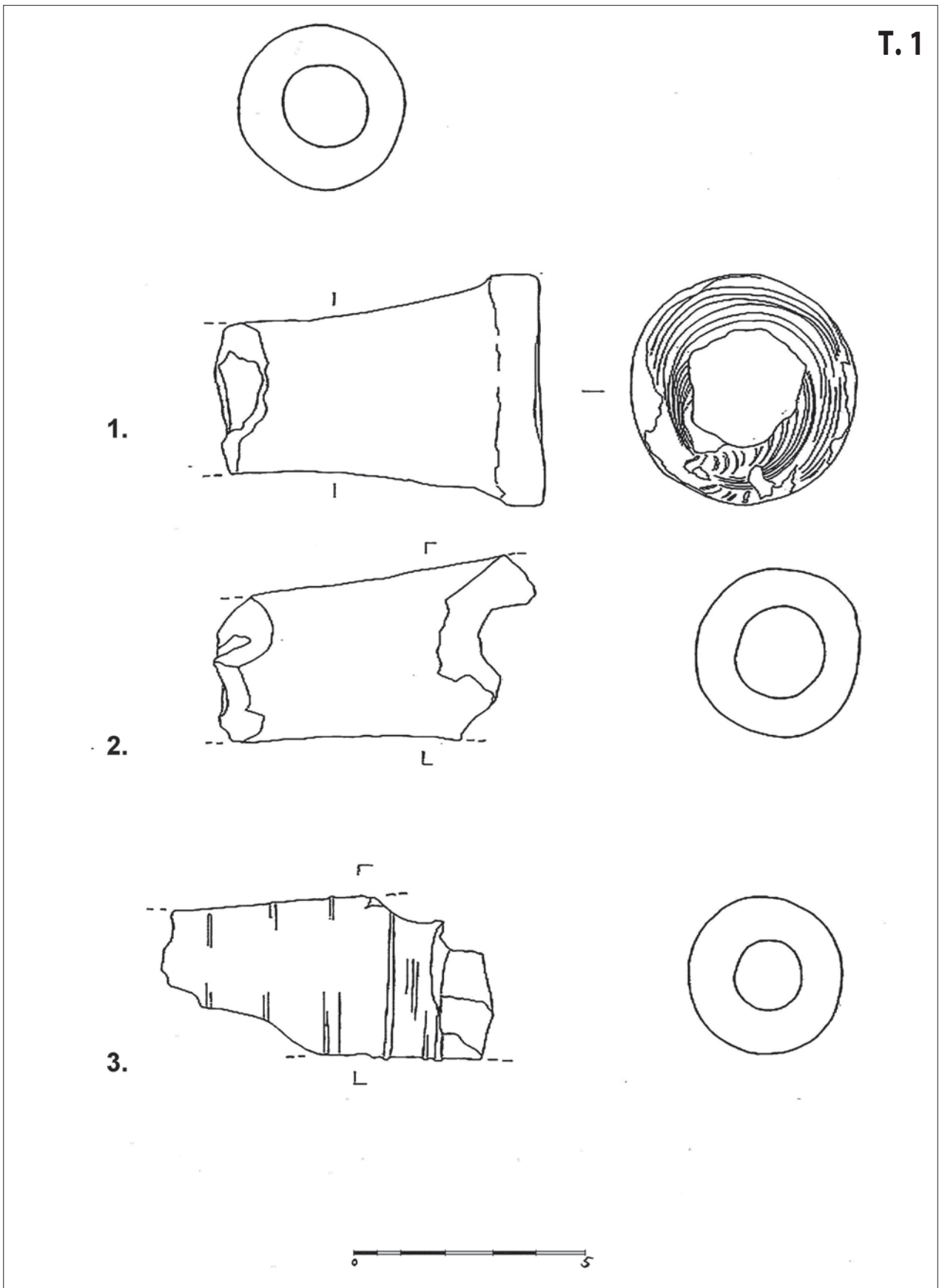

T. 1 Clavi coctiles s položaja Šokadija u Vinkovcima (crtež: S. Čule)

Pl. 1 Clavi coctiles from the position Šokadija in Vinkovci (drawing by: S. Čule)

T. 2

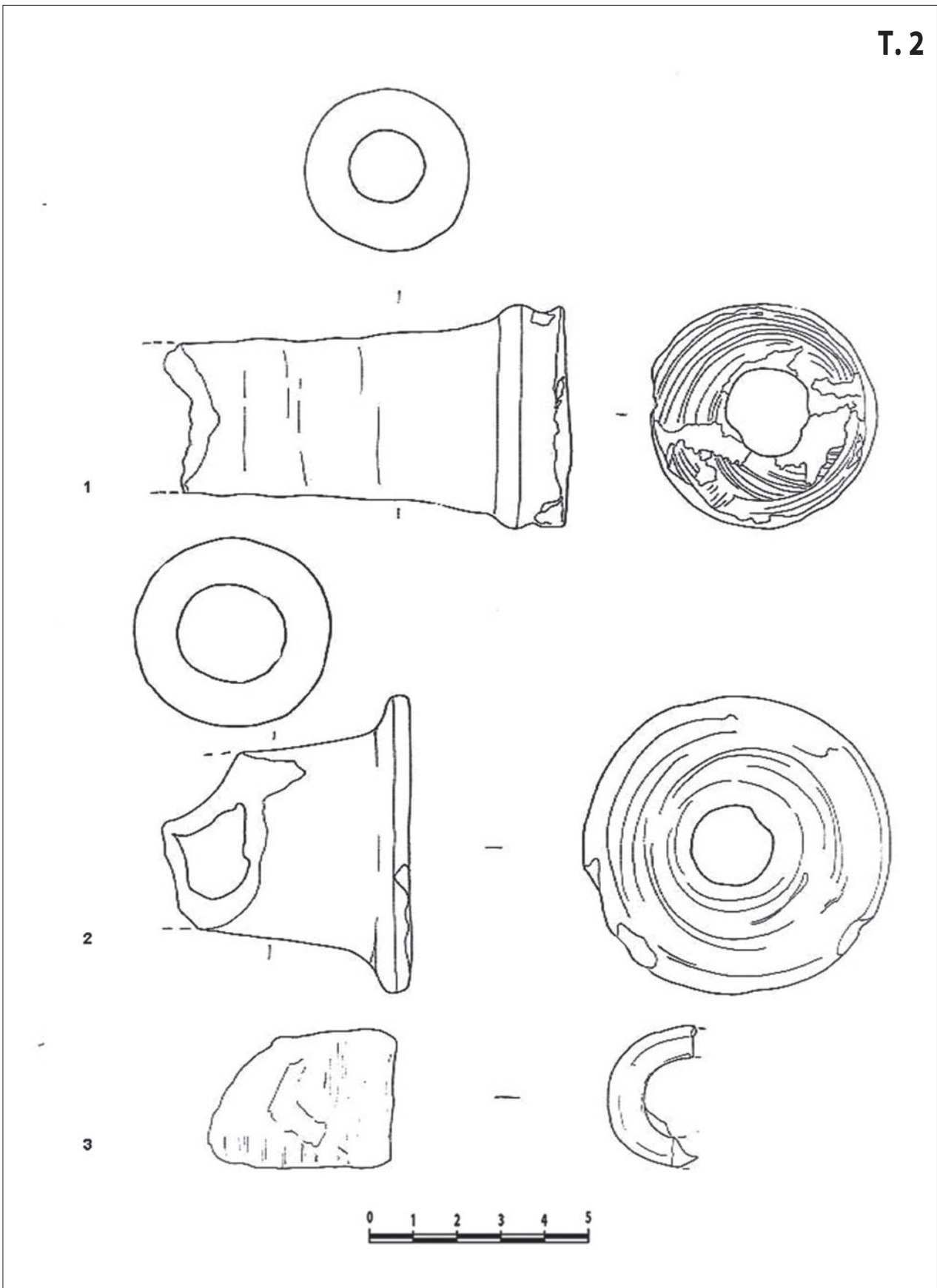

T. 2 *Clavi coctiles* s položaja Šokadija u Vinkovcima (crtež: S. Čule)

Pl. 2 *Clavi coctiles* from the position Šokadija in Vinkovci (drawing by: S. Čule)

T.3

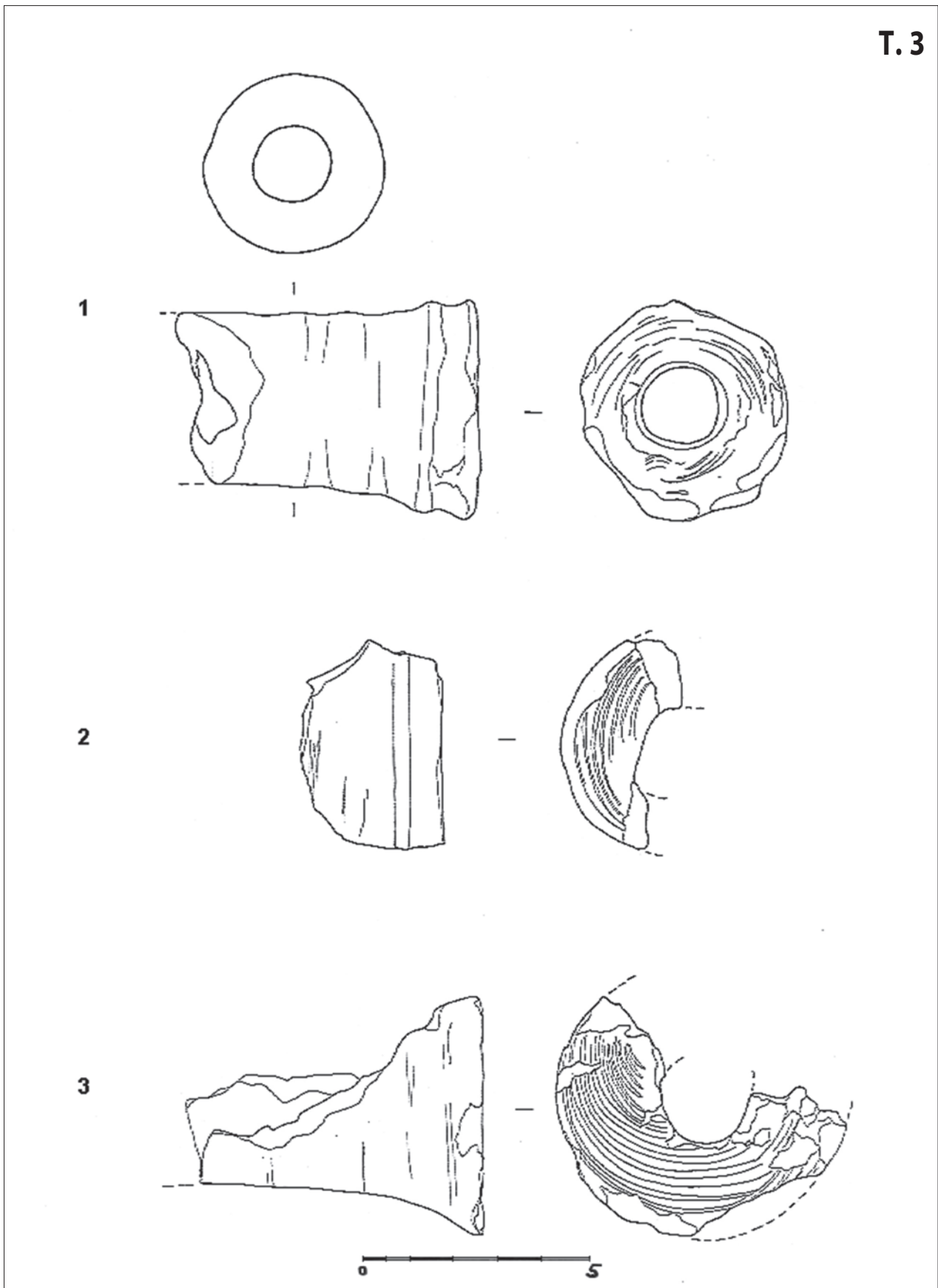

T. 3 *Clavi coctiles* s položaja Šokadija u Vinkovcima (crtež: S. Čule)

Pl. 3 *Clavi coctiles* from the position Šokadija in Vinkovci (drawing by: S. Čule)

T. 4

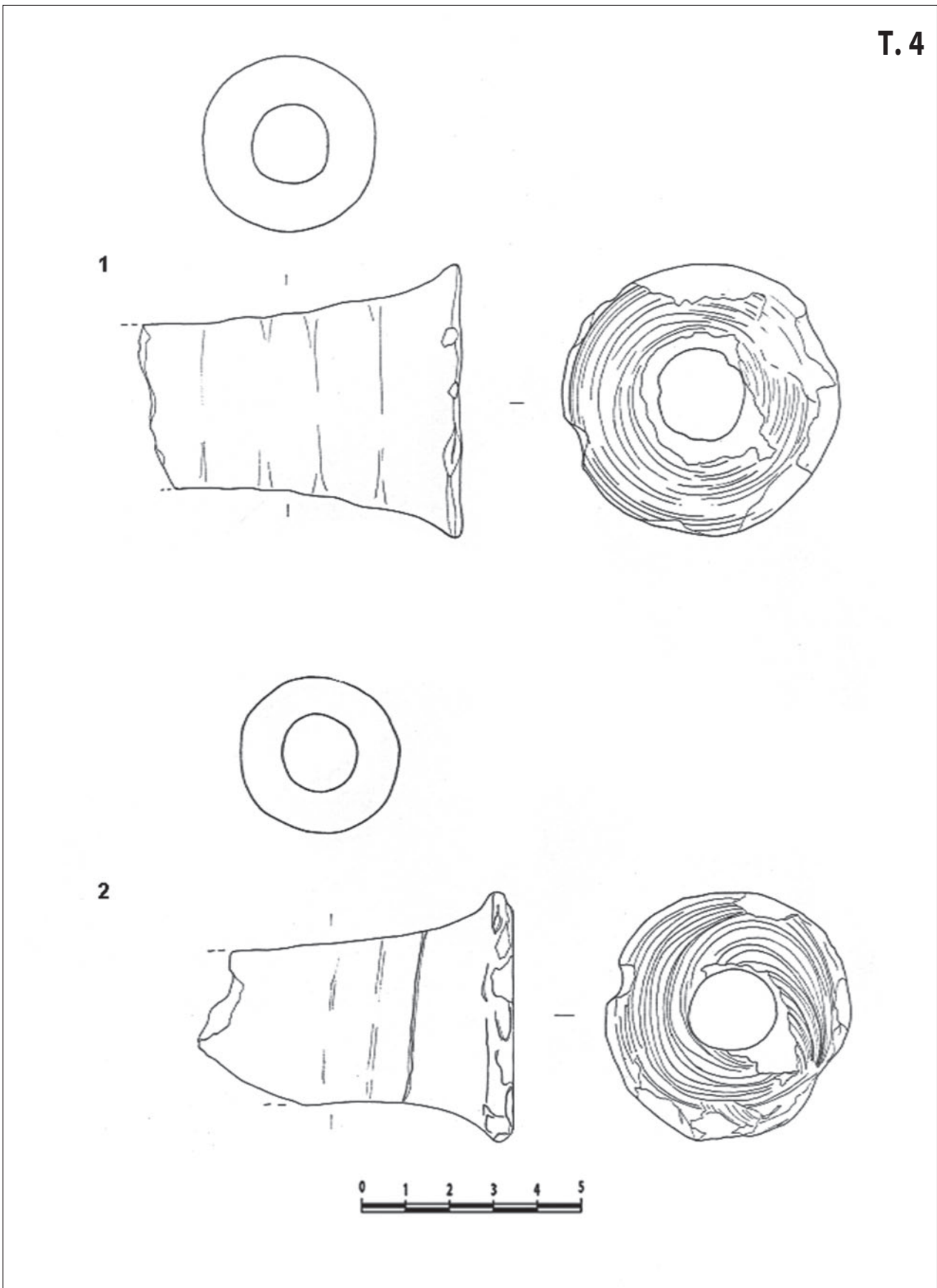

T. 4 *Clavi coctiles* s položaja Šokadija u Vinkovcima (crtež: S. Čule)  
Pl. 4 *Clavi coctiles* from the position Šokadija in Vinkovci (drawing by: S. Čule)