

Mathematical Method for Droplet Size Distribution of Agricultural Nozzles

Kurt TOMANTSCHGER, Dragan V. PETROVIĆ, Rade L. RADOJEVIĆ, Vjekoslav TADIĆ*

Abstract: One of the technical factors from agricultural nozzles and overall plant protection is droplet diameter, which exclusively depends on working pressure, ISO number and nozzle type. Therefore, this paper was aimed to describe mathematical model for droplet size distribution. Through field exploitation experiment, data was used from three ISO numbers of nozzles (hollow cone 80 015; 02 and 03), two air-assisted sprayers (axial and radial fan) and two permanent crops (vineyard and an apple orchard). Water sensitive papers were used for evaluation of droplet diameters, and digital image analysis with Image J software was used for data processing. Mathematical model through homogenous diffusion equation and simplified differential equation shows that droplet size distribution had exponential function of modelling. Theoretical mathematical model was confirmed in experimental results, where coefficient of determination of exponential regression model for 80 015 nozzles was 0.93 with 5.15 of *RMSE*. The same coefficient for 80 02 nozzles was 0.96 with 2.88 of *RMSE* and for 80 03 nozzle R^2 was 0.93 with 3.25 of *RMSE*. In addition, it is proved that droplet diameter depends on operating pressure with very high negative correlation (80 03 nozzles: $r = -0.98$; 80 02 nozzles: $r = -0.97$; 80 015 nozzles: $r = -0.95$). This data will help future researchers in their papers to facilitate and describe similar models for plant protection processes, and all agricultural producers to determine optimal operating pressure which is immensely important in economic, biologic, technical and ecologic aspect.

Keywords: agricultural nozzles; diffusion equations, droplet size distribution; partial differential equation; plant protection

1 INTRODUCTION

Agricultural nozzles are the most important parts for all plant protection machines and the executive element, which manages the whole process of pesticide application [1]. The most of nozzles (except for some manufacturers) are marked according to ISO 10625 standard (each nozzle is marked with a trade name, type of nozzle, spraying angle, and nozzle flow in American gallons) [2] and they determine: spray uniformity, coverage of sprayed area, amount of sprayed liquid, drift potential, number of droplets per sprayed area and droplet diameter (depending of working pressure) [3]. With the mentioned standard, every nozzle has defined liquid flow at particular pressure, e.g. blue nozzle (mark 03) at 3 bar (standard) has liquid flow of 1.2 l min^{-1} (to double the flow rate, the pressure should be quadruplicate) [4]. Agricultural nozzles can be made of plastic materials, brass, stainless steel, ceramic (most commonly used nozzles are with plastic body and with a ceramic insert).

One of the main technical factors of the agricultural nozzles is droplet diameter, which is decreasing by increasing the working pressure [5]. In addition, by increasing the working pressure, the number of droplets in spray is increasing [6]. With this droplet diameter reduction, bigger number of droplets are being created in the spray, resulting with higher area coverage [7]. This is extremely important because in this way the effect of applied pesticide is increased. So to conclude, a higher number of small droplets cause greater surface coverage, which affect greater pesticides effectiveness. Coverage of treated area is the main goal of the whole plant protection process, and the main task of technical spraying factors is to increase this property, especially with management of droplet size distribution [8].

Many authors are interested in researching this area, so they investigate air velocity of air-assisted sprayers [9], spraying norm [8], nozzle position and orientation [10], nozzle types [11], spraying speed [12] and vertical liquid distribution [13]. The authors [3, 14] study the impact of different *ISO* nozzle type on optimum surface coverage and drift intensity within permanent crops, and they are stating that nozzles with smaller *ISO* number achieve better

coverage of the treated surface, but increased liquid drift, due to smaller droplets.

The most common method to evaluate droplet size distribution, number of droplets per cm^2 , drift and area coverage is with water sensitive papers (WSP) and digital image analysis (DIA) [1, 3-6, 8, 11, 13, 15-17]. The method is affordable and cheap, and therefore it is most widely used, unlike the methods with infrared lasers. The method with lasers is more accurate, but the method with WSP papers satisfies scientific standards. With this much concern about the droplets size and application techniques, and with advanced of agricultural engineering, the emphasis is on the use of sensors to achieve even greater accuracy of the application [14, 18-19].

Knowing all these facts, we come to a cognition how important this area is - in economic, biologic, technical and ecologic aspect. Therefore, it is essential to use mathematical models for describing the mentioned figures and technical legalities. Many authors are developing and describing different models with diffusion and differential equations for distribution of different properties, such as: waterborne particle sizes [20, 21] and particle sizes of filter granulation [22, 23]. In addition, different mathematical models are being developed for durability of agricultural tractors [24], surface roughness of artificial cell wall materials [25] and fertilizer particle motion [26]. Some authors are investigating models of sowing process with different types of sowing machines in the function of longitudinal, lateral and seed depth distribution [27, 28].

Diffusion processes are described by partial differential equations with parabolic type (1). They have the canonical form:

$$\frac{\partial^2 y}{\partial x^2} = G\left(x, t, y, \frac{\partial y}{\partial x}, \frac{\partial y}{\partial t}\right), y = y(x, t). \quad (1)$$

Such equations probably occur more commonly than any other type of partial differential equations in applied science, because they arise as models of many physical, chemical and biological processes. The most basic is the heat (diffusion) equation [33], which describes the flow of heat by conduction through a stationary, homogeneous and isotropic material. Heat sources and sinks can be present.

Equations are often referred to as diffusion equations because they also model diffusive mass transfer. Such processes occur, for example, when modelling the distribution of a pollutant in a river along the x -axis [34]. With a unidirectional flow in the space, this equation gets more complicated. The heat conduction comes about through the random agitation of certain modes of oscillation of atoms. Therefore, the diffusion equations also appear in probability and finance, because they can be obtained from "random-walk" or "Brownian-motion" models [35]. The diffusion equations also arise in vector form in electromagnetism and astronomy [36].

2 MATERIAL AND METHODS

This material and the scientific method were already used in the mentioned papers as an authoritative research.

2.1 Sprayers and Nozzles

In this study, two mounted orchard sprayers were used: axial fan orchard sprayer with high altitude air routers and radial fan orchard sprayer with tangential air. Research was done on two types of permanent crops: vineyard [4], and apple orchard [8]. In both parts of the research, the same technical parameters of spaying are used (nozzles, working speed, spraying norm and the working pressure were adjusted according to the particular treatment). The study used three models of hollow cone nozzles with same characteristics but different marks: 80015C (green), 8002C (yellow) and 8003C (blue). All selected nozzles are marked according to ISO 10625:2005 standard. Dimensions of nozzles are shown in Fig. 1.

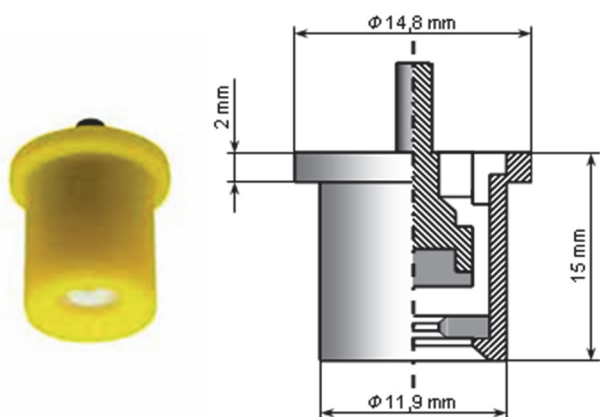

Figure 1 Dimensions of hollow cone nozzles

2.2 Calculation of Research Parameters

Working speed of sprayers was set in the range of optimal agrotechnical speeds at 6 and 8 km/h. Spraying norm was adjusted accordingly to the volume of permanent crop, used nozzle and working speed (apple orchard: 250, 325 and 400 l/ha; vineyard: 250, 300 and 350 l/ha). After determination of crop volume and spraying norm, the next step of sprayer calibration was to calculate required nozzle flow and pressure. Nozzle flow was calculated from equation:

$$Q_m = \frac{N_r \cdot v_r \cdot b_r}{n \cdot 600}, \quad (2)$$

where is: Q_m - nozzle flow, l/min; N_r - spraying norm, l/ha; b_r - row width, m; n - number of nozzle in exploitation. Final step of calibration is to calculate required pressure with equation:

$$\frac{Q_1}{Q_2} = \sqrt{\frac{p_1}{p_2}}, \quad (3)$$

where is: Q_1 - liquid flow at pressure p_1 , l/min; Q_2 - liquid flow at pressure p_2 , l/min; p_1 - pressure at Q_1 - liquid flow, bar; p_2 - pressure at Q_2 - liquid flow, bar.

2.3 Water Sensitive Papers (WSP)

The row width was 3.5 m in an apple orchard and 2.8 m in a vineyard and 10 nozzles were installed on both sprayers. Airflow and velocity were set accordingly to the volume of permanent crops. WSP are yellow rectangular strips (75 × 25 mm) and on surface, they have a thin layer of bromophenol, which in contact with water turns blue. Therefore, the droplets that fall on a WSP were used for determination of average droplet diameter (Fig. 2).

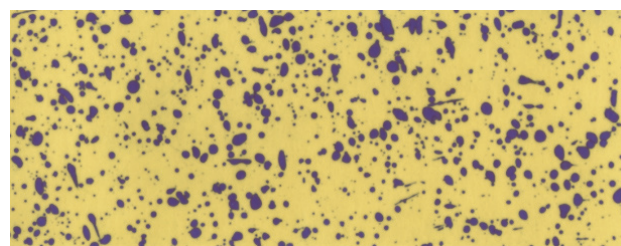

Figure 2 Water sensitive paper

2.4 Digital Image Analysis (DIA)

After field research, the WSP samples were collected and each one was analysed by using the digital image analysis (DIA). The basic elements of the DIA system used in this research were a lightening chamber with 8 halogen lamps arranged in a circle that forms top lighting, and lower lighting with energy saving bulb, which is located below the surface of sandblasted glass on which the sample is placed. Inside of lightening chamber, there is a digital camera, located in the upper part of the chamber within 60 cm from the sample.

Before the analysis, the entire system needs to go through the calibration process [29, 30]. After taking the samples, images are stored in TIFF format. On images, automatic computer command (macro) was applied in Adobe Photoshop® software, with the purpose of segmentation and separation of the sample surface. The next step is image processing with ImageJ software [1, 31, 32].

2.5 Previous Research

In chapter experimental results, data is retrieved from [3, 4, 8], and reorganized to show average droplet diameter through three models of nozzles, according to working pressure as treatment requires (e.g. in treatment Y/8/350 average droplet diameter is shown for both of the sprayers and permanent crops). Data is retrieved from PhD thesis [3], and used methodology in this paper was also used in

[4, 8]. This method of data display is required to demonstrate and confirm mathematical model for droplet size distribution shown in the next chapter.

3 MATHEMATICAL MODEL

The general form of a homogenous diffusion equation with one space variable x and the time variable t and the unknown distribution $y(x, t)$ possesses the form:

$$\frac{\partial}{\partial x} \left[K(x) \frac{\partial y}{\partial x} \right] + L(x) \frac{\partial y}{\partial t} = 0. \quad (4)$$

Since the general solution of the diffusion equation could not be calculated yet, the solution must be derived for each $K(x)$ and $L(x)$ extra.

$$y_t = \left[-\frac{1}{2(b+2cx)} + 2c \frac{a+bx+cx^2}{(b+2cx)^3} \right] y_x - \frac{a+bx+cx^2}{(b+2cx)^2} y_{xx} \quad (5)$$

It describes the droplet size distributions of agricultural nozzles. The unknown function $y(x, t)$ is the volume percent proportion, x is the droplet diameter and $t \geq 0$ is the time. a , b and c are fitting constants. The problem is to find the solution of this differential equation. First, it is shown that (5) really is a diffusion equation. If we express y_t in (4) explicitly and compare the coefficients of this equation to those of (5), we obtain the two determination equations:

$$\frac{K'}{L} = \frac{1}{2(b+2cx)} - 2c \frac{a+bx+cx^2}{(b+2cx)^3}, \quad ' = \frac{d}{dx}, \quad (6)$$

And

$$\frac{K}{L} = \frac{a+bx+cx^2}{(b+2cx)^2}. \quad (7)$$

Dividing Eq. (6) by (7) gives:

$$\frac{K'}{K} = \frac{b+2cx}{2(a+bx+cx^2)} - \frac{2c}{b+2cx}. \quad (8)$$

Integrating this conditional equation of K , we obtain:

$$K(x) = c_1 \frac{\sqrt{a+bx+cx^2}}{b+2cx}, \quad (9)$$

where c_1 represents any arbitrary constant. Inserting (9) in (7) yields the second coefficient of (4):

$$L(x) = c_1 \frac{b+2cx}{\sqrt{a+bx+cx^2}}. \quad (10)$$

Therefore, it was proved that the differential equation (5) to be solved really represents a diffusion equation. c_1

can be set to = 1, or after inserting (9) and (10) in (4), c_1 can be cut out from this equation.

The shape of the solution function of a differential equation depends on the coefficients and the linearity or nonlinearity of the equation. To get an idea of what the solution to Eq. (5) could look like, we make the following considerations:

3.1 Simplification of (5)

The polynomial of second order $a+bx+cx^2$ occurs with its first and second derivative in the coefficients of (5). This diffusion equation to be solved is simplified by using the simplest polynomial of second order. This is cx^2 . Taking $a=b=0$ in (5) and using $c < 0$, Eq. (5) is simplified to:

$$y_t = \frac{1}{4|c|} y_{xx}. \quad (11)$$

The solution of (11) is given by:

$$y(x, t) = \frac{C}{\sqrt{t}} e^{cx^2 t^{-1}}, \quad (12)$$

where C is arbitrary constant.

3.2 Complicating the Solution of the Simplified Differential Eq. (11)

Since $a=b=0$ was set in the simplification of (5), it is obvious that the solution of (5) could have the form:

$$y(x, t) = Ct^p e^{s(a+bx+cx^2)t^q}, \quad p \neq 0, q \neq 0, s \neq 0. \quad (13)$$

The constants p , q and s must be determined. For this, the assumed solving function (13) is substituted into the differential equation (5). That delivers:

$$s(st^{2q+1} + qt^q)(a+bx+cx^2) + \frac{s}{2}t^{q+1} + p = 0, \quad (14)$$

where x and t are independent variables. So a comparison of x resp. t powers can be made. Dividing (14) by t^q and equating the coefficients of like powers of x yields the three conditional equations:

$$as(st^{q+1} + q) + \frac{s}{2}t + pt^{-q} = 0, \quad (15)$$

$$bs(st^{q+1} + q) = 0, \quad (16)$$

$$cs(st^{q+1} + q) = 0. \quad (17)$$

$b=0$ and/or $c=0$ do not preserve the diffusion Eq. (5) and $s=0$ was already excluded in (13). So the determination Eqs. (16) and (17) imply that the third factor in these equations vanishes. The coefficient comparison

with respect to t powers in Eqs. (16) and (17) only yields a useful solution if $q = -1$. Therefore, $s + q = 0$, resp. $s = 1$. Inserting these values into (15) implies $p = -1/2$. Hence, the solution (13) becomes:

$$y(x, t) = \frac{C}{\sqrt{t}} \exp\left[\frac{a + bx + cx^2}{t}\right]. \quad (18)$$

The best fitting function is obtained at $C = 1$, i.e.

$$y(x, t = 1) = e^{a + bx + cx^2}. \quad (19)$$

This even is a particular solution of the differential Eq. (5).

4 EXPERIMENTAL RESULTS

Tab. 1 shows all the results connected to treatment (model of nozzle, working speed, spraying norm) and required operating pressure for treatment realization (e.g. for spraying norm of 350 l/ha and working speed of 6 km/h and by using 80 03 nozzles, required operating pressure is 2.97 bar; for 80 02 nozzles 6.38 bar; and 10.99 bar for 80 015 nozzles (Eqs. (1), (2)). Demonstrated results are means for both of the sprayers and permanent crops.

Table 1 Results of droplet size distribution for research properties

Treatment	p / bar	d / μm	Treatment	p / bar	d / μm	Treatment	p / bar	d / μm
B/6/250	1.51	223.74	Y/6/250	3.25	191.84	G/6/250	5.60	181.47
B/6/300	2.18	214.62	Y/6/300	4.68	188.69	G/6/300	8.07	176.80
B/6/325	2.56	205.40	Y/6/325	5.50	178.05	G/6/325	9.47	164.61
B/8/250	2.69	201.70	Y/8/250	5.78	178.86	G/8/250	9.96	160.05
B/6/350	2.97	202.83	Y/6/350	6.38	180.98	G/6/350	10.99	167.14
B/6/400	3.88	192.68	Y/6/400	8.33	169.29	G/6/400	14.35	143.21
B/8/325	4.56	181.44	Y/8/325	9.78	160.21	G/8/325	16.84	132.56
B/8/350	5.29	182.61	Y/8/350	11.34	162.33	G/8/350	19.53	126.63
B/8/400	6.90	159.24	Y/8/400	14.81	143.80	G/8/400	25.52	120.76
R^2	0.9375		R^2	0.9623		R^2	0.9352	
$R^2_{adj.}$	0.9286		$R^2_{adj.}$	0.9569		$R^2_{adj.}$	0.9259	
$RMSE$	3.25		$RMSE$	2.88		$RMSE$	5.15	

Treatment: B (blue nozzle) - 80 03; Y (yellow nozzle) - 80 02; G (green nozzle) - 80015; 6, 8 km/h; 250, 300, 325, 350, 400 l/ha; p - operating pressure; d - average droplet diameter

The result of quoted is average droplet diameter which is solely dependent on operating pressure - very high negative correlation (80 03 nozzles: $r = -0.9840$; 80 02 nozzles: $r = -0.979$; 80 015 nozzles: $r = -0.9587$). Average droplet diameter in each group is decreasing with pressure increment (80 03: from 223.74 to 159.24 μm ; 80 02: from 191.84 to 143.80 μm and 80 015: from 181.47 to 120.76 μm) according to exponential dynamics, which is shown in the mathematical modelling chapter (Figs. 3, 4 and 5). Comparing the droplet size between nozzle groups at same operating pressures, the largest droplets generate 80 02 nozzles, and the smallest generate 80 015 nozzles (as described by the ISO standard) [2]. This means that nozzles with higher ISO number generate higher nozzle flow and bigger droplet size distribution.

functions indicate that droplet size distribution follows the well-known exponential distribution function. A variety of different fitting functions had been tested for this property, and exponential achieved the highest accuracy. In Fig. 3 is shown droplet size distribution for 80 03 nozzles (blue). R^2 value is 0.9375 ($R^2_{adj.} = 0.9286$) with 3.25 of $RMSE$.

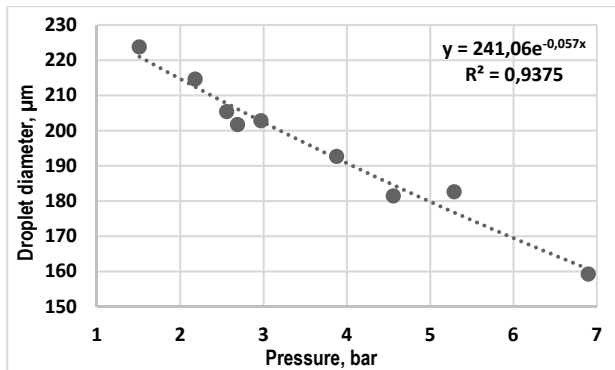

Figure 3 Droplet size distribution for 80 03 nozzles

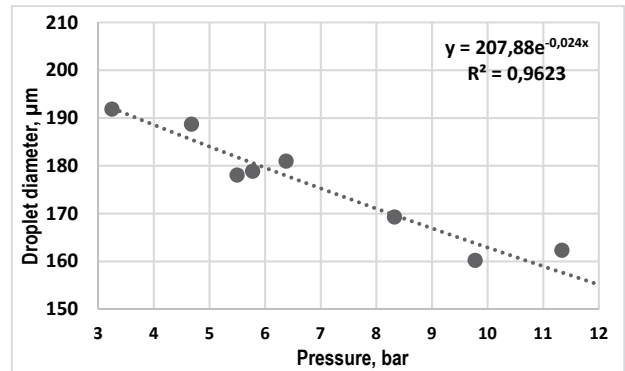

Figure 4 Droplet size distribution for 80 02 nozzles

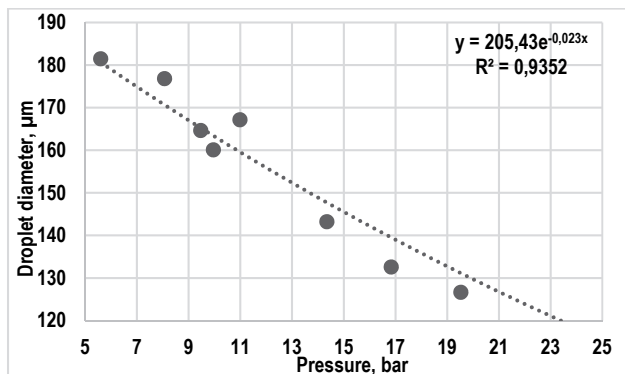

Figure 5 Droplet size distribution for 80 015 nozzles

As can be seen in next Figs. 3, 4 and 5, the quality of fitting procedure is very good and precisely for tested property. R - square value in all three cases is higher than 0.93 (as well as adjusted R - square), while the root mean square error ($RMSE$) is low enough. The shapes of these

In Fig. 4 is shown droplet size distribution for 80 02 nozzles (yellow). R^2 value is 0.9623 ($R^2_{adj.} = 0.9569$) with 2.88 of $RMSE$.

In Fig. 5 is shown droplet size distribution for 80 015 nozzles (green). R^2 value is 0.9325 ($R^2_{adj.} = 0.9259$) with 5.15 of $RMSE$. From these three cases, very important is that $RMSE$ value is so low because the required accuracy of the model is achieved and the experiment results are very close to the classification line.

5 CONCLUSION

A very important prerequisite for a good plant protection is optimally adjusted technical spraying factors, with an optimal droplet size distribution, which is the most important. The paper presents and gives solution of diffusion/differential equation for description of droplet size distribution in the shape of exponential function, i.e. this paper shows quite satisfactorily results for mathematical modelling of crop protection process. Mentioned model, which are partial differential equations, was experimentally verified through described materials and methods.

Model of fitting accuracy for exponential function is quite high with coefficients of determination greater than 0.93, while the root mean square errors are less than 5. In addition, it was proved the droplets size dependence on the operating pressure (coefficient of correlation from 0.95-0.98). This data will help future researchers in their papers to facilitate and describe similar models for plant protection processes, which is immensely important in economic, biologic, technical and ecologic aspect. In addition, this research will help all agricultural producers to determine optimal field operating pressure to reduce drift and increase area coverage for better effectiveness of pesticides.

Acknowledgements

The investigation presented in this paper is a part of the project entitled "Improvement of biotechnological procedures as a function of rational utilization of energy, agricultural products productivity and quality increase" funded by the Ministry of Education and Scientific and Technological Development of the Republic of Serbia, grant No TR-31051 within the framework of the contract for the realization and financing of scientific research work in 2020 between the Faculty of Agriculture in Belgrade and the Ministry, contract registration number: 451-03-68/2020-14/200116.

6 REFERENCES

- Petrović, D. V., Radojević, R. L., Vukša, P., & Golubović, Z. Z. (2012). Droplet size distribution of conventional and air-induced nozzles. *DAS 29, 29th Danubia-Adria Symposium on Advances in Experimental Mechanics, Beograd, Serbia*, 170-173.
- Banaj, Đ., Tadić, V., Banaj, Ž., & Lukač, P. (2010). *Improvement of pesticide application techniques*. University textbook, University of J. J. Strossmayer in Osijek, Faculty of agrobiotechnical sciences, 48-137.
- Tadić, V. (2013). *Impact of technical spraying factors on leaf area coverage in permanent crops*. PhD thesis, Faculty of agrobiotechnical sciences in Osijek.
- Tadić, V., Zebec, V., Ravlić, M., Brozović, B., Ilić, J., & Vujčić, B. (2016). Impact of technical spraying factors on leaf area coverage in a vineyard. *Agronomy journal*, 78(5-6), 215-230.
- Wolf, R. E., Gardisser, D. R., & Williams, W. L. (1999). Spray Droplet Analysis of Air Induction Nozzles Using WRK DropletScan Technology. *Proceedings of 33rd Annual National Agricultural Aviation Association Convention, Reno, USA*, 7.
- Wolf, R. E. (2003). Assessing the ability of droplets can to analyze spray droplets from a ground operated sprayer. *Applied Engineering in Agriculture*, 19(5), 525-530. <https://doi.org/10.13031/2013.15310>
- Cross, J. V., Walklate, P. J., Murray, R. A., & Richardson, G. M. (2003). Spray deposits and losses in different sized apple trees from an axial fan orchard sprayer. *Crop protection*, 22(2), 381-394. [https://doi.org/10.1016/S0261-2194\(02\)00192-8](https://doi.org/10.1016/S0261-2194(02)00192-8)
- Tadić, V., Marković, M., Plaščak, I., Stošić, M., Lukinac-Čačić, J., & Vujčić, B. (2014). Impact of technical spraying factors on leaf area coverage in an apple orchard. *Technical Gazette*, 21(5), 1117-1124.
- Wei, Q., Sanqin, Z., Weimin, D., Chengda, S., Jiang, L., Yinian, L., & Jiabing, G. (2016). Effects of fan speed on spray deposition and drift for targeting air-assisted sprayer in pear orchard. *International Journal of Agricultural and Biological Engineering*, 9(4), 53.
- Landers, A. & Farooq, M. (2004). Reducing Spray Drift from Orchards. *New York Fruit Quarterly*, 12, 23-26.
- Derksen, R.C., Zhu, H., Fox, R. D., Brazee, R. D., & Krause, C. R. (2007). Coverage and drift produced by air induction and conventional hydraulic nozzles used for orchard applications. *Transactions of ASABE*, 50, 1493-1501. <https://doi.org/10.13031/2013.23941>
- Celen, I. H., Arin, S., & Durgut, M. R. (2008). The effect of the air blast sprayer speed on the chemical distribution in vineyard. *Pakistan Journal of Biological Sciences*, 11, 1472-1476. <https://doi.org/10.3923/pjbs.2008.1472.1476>
- Vujčić, B., Tadić, V., Marković, M., Lukinac-Čačić, J., Stošić, M., & Plaščak, I. (2015). Impact of technical spraying factors on vertical liquid distribution with Agromehanika AGP 440 axial fan sprayer. *Tehnički vjesnik - Technical Gazette*, 22(2), 367-373. <https://doi.org/10.17559/TV-2014033114184>
- Petrović, D., Banaj, Đ., Banaj, A., Barač, Ž., Vidaković, I., & Tadić, V. (2019). The Impact of Conventional and Sensor Spraying on Drift and Deposit in Cherry Orchard. *Tehnički vjesnik - Technical Gazette*, 26(5), 1211-1217. <https://doi.org/10.17559/TV-20171206133147>
- Mahmood, H.S., Iqbal, M., Hussain, A., & Hamid, T. (2004). Improved surface coverage with environmentally effective university boom sprayer. *Pakistan Journal of Agricultural Science*, 41(3-4), 152-157.
- Panneton, B. & Lacasse, B. (2004). Effect of air-assistance configuration on spray recovery and target coverage for a vineyard sprayer, *Canadian Biosystem Engineering*, 46(2), 13-2.18.
- Marcal, R. S. (2008): Alternative Methods for Counting Overlapping Grains in Digital Images Image Analysis and Recognition. *Lecture Notes in Computer Science*, 5112, 1051-1060. https://doi.org/10.1007/978-3-540-69812-8_105
- Petrović, D., Jurišić, M., Tadić, V., Plaščak, I., & Barač, Ž. (2018). Different sensor systems for the application of variable rate technology in permanent crops. *Tehnički Glasnik - Technical Journal*, 12(3), 188-195. <https://doi.org/10.31803/tg-20180213125928>
- Petrović, D., Jurišić, M., Plaščak, I., Duvnjak, V., Marković, M., Banaj, A., & Tadić, V. (2019). Impact of selective application with ultrasonic sensors on drift and liquid deposit

- in the cherry orchard. *Agriculture*, 25(1), 89-98.
<https://doi.org/10.18047/poljo.25.1.13>
- [20] Tasić, S. J., Golubović, Z. Z., Petrović, D. V., & Golubović, Z. D. (2009). On the Applicability of Morphometric Method for Evaluation of the Waterborne Particles Size Distribution. *Proceedings of 26th Symposium on Advances in Experimental Mechanics*, 227-228.
- [21] Tomantschger, K., Petrović, D. V., & Radojević, R. L. (2018). Determination of the Probability Size Distribution of Solid Particles in a Technical Water. *Evaluations in Mechanical Engineering*, 1(3), 514.
- [22] Tomantschger, K., Petrović, D. V., Golubović, Z. D., & Trisović, N. (2012). Mathematical Model for the Particle Size Distribution of a Kieselguhr Filter Granulation. *Metalurgia International*, 17(10), 192-197.
- [23] Tomantschger, K., Petrović, D. V., Radojević, R. L., Golubović, Z. Z., & Tadić, V. (2014). One-Dimensional Diffusion Equation for the Particle Size Distribution of Perlite Filter Granulation. *Tehnički vjesnik - Technical Gazette*, 24(3), 943-948.
<https://doi.org/10.17559/TV-20151202204533>
- [24] Tomantschger, K., Petrović, D. V., Golubović, Z. D., & Mileusnić, Z. I. (2011). Differential equation model for durability of tractors with application to the model Massey Ferguson 8160. *African Journal of Agricultural Research*, 6(18), 4385-4391.
- [25] Petrović, D. V., Golubović, Z., Dajić, Z., Tomantschger, K., & Radojević R. L. (2012). Mathematical Modelling the Surface Roughness Distribution of Artificial Cell Wall Materials, *Facta Universitatis: Mechanical Engineering*, 10, 1-6.
- [26] Tomantschger, K., Petrović, D. V., Cerović, V. B., Dimitrijević, A. Z., & Radojević, R. L. (2018). Prediction of a Fertilizer Particle Motion along a Vane of a Centrifugal Spreader Disc Assuming its Pure Rolling. *FME Transactions*, 46(4), 544-551.
<https://doi.org/10.5937/fmet1804544K>
- [27] Karayel, A. & Zmerzi, O. (2007). Comparison of Vertical and Lateral Seed Distribution of Furrow Openers Using a New Criterion. *Comparison of Research*, 95, 69-75.
<https://doi.org/10.1016/j.still.2006.11.001>
- [28] De Silveira, P. M., Nascente, A. S., & Da Silva, J. G. (2018). The effect of longitudinal distribution and seed depth on grain yield of common bean. *Journal of seed science*, 40(1), 90-97.
<https://doi.org/10.1590/2317-1545v40n178801>
- [29] Papadakis, S. E., Abdul-Malek, S., Kamdem, R. E., & Yam, K. L. (2000). A Versatile and Inexpensive Technique for Measurement Colour of Foods. *Food Technology*, 54, 48-51.
- [30] Wee, A. G., Lindsey, D. T., Kuo, S., & Johnston, W. M. (2006). Colour accuracy of commercial digital cameras for use in dentistry. *Dental Material*, 22, 553-559.
<https://doi.org/10.1016/j.dental.2005.05.011>
- [31] Zhu, H., Salyani, M., & Fox, R. D. (2011). A portable scanning system for evaluation of spray deposit distribution. *Computers and Electronics in Agriculture*, 76, 38-43.
<https://doi.org/10.1016/j.compag.2011.01.003>
- [32] Prodanov, D. & Verstreken, K. (2012). Automated Segmentation and Morphometry of Cell and Tissue Structures. Selected Algorithms in ImageJ. In *tech, open sciens/open minds, Molecular Imaging*, 183-208.
<https://doi.org/10.5772/36729>
- [33] Ockendon, J., Howison, S., Lacey, A., & Movchan, A. (2003). *Applied Partial Differential Equations*. Oxford University Press.
- [34] Ruegner, H., Schwientek, M., Egner, M., & Grathwohl, P. (2013). Monitoring of event-based mobilization of hydrophobic pollutants in rivers: Calibration of turbidity as a proxy for particle-facilitated transports in field and laboratory. *Elsevier*.
<https://doi.org/10.1016/j.scitotenv.2014.04.110>
- [35] Karatzas, I. & Shreve, St. E. (1997). *Brownian Motion and Stochastic Calculus*. Springer, New York.
- [36] *Advances in Space Research* (1983). Electromagnetic effects on planetary rings. *Elsevier*, 3, 87-94.
[https://doi.org/10.1016/0273-1177\(83\)90261-2](https://doi.org/10.1016/0273-1177(83)90261-2)

Contact information:

Kurt TOMANTSCHGER, PhD, Associate professor
 University of technology Graz,
 Faculty of Mathematics, Physics and Geodesy,
 Steyrergasse 30, 8010 Graz, Austria
 E-mail: tomantschger@tugraz.at

Dragan V. PETROVIĆ, PhD, Full professor
 University of Belgrade, Faculty of Agriculture,
 Nemanjina 6, 11 081 Belgrade - Zemun, Serbia
 E-mail: epetrodr@agrif.bg.ac.rs

Rade L. RADOJEVIĆ, PhD, Full professor
 University of Belgrade, Faculty of Agriculture,
 Nemanjina 6, 11 081 Belgrade - Zemun, Serbia
 E-mail: rrade@agrif.bg.ac.rs

Vjekoslav TADIĆ, PhD, Associate professor
 (Corresponding author)
 University of J. J. Strossmayer in Osijek,
 Faculty of Agrobiotechnical Sciences Osijek,
 Vladimira Preloga 1, 31000 Osijek, Croatia
 E-mail: vtadic@fazos.hr