

## MERCURY IN SOIL AND ATMOSPHERE AS A PATHFINDER ELEMENT FOR ISTRIAN BAUXITE DEPOSITS — A TENTATIVE EXPLORATION MODEL

Ladislav A. PALINKAŠ\*, Sergej E. SHOLUPOV\*\*, Boris ŠINKOVEC\*, Slobodan MIKO\*,  
Tatjana SESVEČAN\*

\* Mining-Geology-Petroleum Engineering Faculty, University of Zagreb, Pierottijeva 6, YU—41000 Zagreb

\*\* Institut Zemnoj kori, University of Leningrad, Univerzitetskaja naberezhnaja, 199164 Leningrad B-164, USSR

**Key-words:** Bauxite, Terra rossa, Trace elements, Mercury, Pathfinder element

In order to find out a secondary dispersion halo of mercury and some other trace elements around the bauxite ore bodies, the authors sampled terra rossa along traverses over them. At the same time, mercury in air is measured and expressed by relative values (mA) using Zeeman mercury vapor analyser. Mercury in soil was determined by flameless atomic absorption method and Cd, Pb, Zn, Cu, Co and Mn by standard AA techniques. The results are equivocal since the natural vertical soil profiles are severely disturbed on traverses due to different land use, what should be taken into consideration during continuation of the survey.

### Introduction

There is a long tradition of using geophysical methods in bauxite exploration in Istria (Rašković, 1979). On the other hand, wide application of Zeeman atomic absorption mercury vapor analyser in ore prospecting (Fursov, 1970, 1977, Mc Carthy, 1973), gas and oil geology, environmental pollution control and even in study of regional tectonic processes (Hajretđinov, 1971, Ozerova, 1984, 1985) motivated authors to examine applicability of the method in conjunction with flameless atomic absorption analysis of mercury in soil, as bauxite exploration technique. There is a good reason for that since the Early Paleogene Istrian bauxites, their carbonate host rocks and pedological formations (terra rossa and gray soil) differ significantly in trace element content (Šinkovec, 1973, 1974, 1976). Simple geology and geometry of the bauxite ore bodies, covered by a terra rossa or Eocene sedimentary cap might have enabled formation of a secondary geochemical halo. The search for it was the primary goal of the survey, but some data on geochemistry of Istrian terra rossa and soil are informative as well.

**Ključne riječi:** Boksit, Terra rossa, Mikroelementi, Živa, Element indikator

U radu je obrađeno istraživanje sekundarne disperzije žive i nekih drugih elemenata oko boksitnih rudnih tijela u Istri. U tu svrhu izvršeno je uzorkovanje terra rosse uzduž traverzi položenih preko boksitnih rudnih tijela. Istovremeno s uzorkovanjem tla vršena su mjerenja pomoću Zeemanovog analizatora živinih para u zraku, a vrijednosti su izražavane u relativnim vrijednostima (mA). Živa u tlu je određivana pomoću metode besplatne atomske apsorpcije, a Cd, Pb, Zn, Cu, Co i Mn standardnom atomskom apsorpcijom. Rezultati ne pokazuju jednoznačnost na terenima s različitim stupnjem poremećenja prirodnog, vertikalnog profila tla (oranica, livada i šuma), što se mora uzeti u obzir prilikom nastavka istraživanja.

### Geological setting of the Early Paleogene Istrian Bauxite

The geological structure of the bauxite bearing area in Istria is simple. According to Polšak (1965), Polšak and Šikić (1966), Šikić and Polšak (1963) and Tišljarić (1978) (Fig. 1), the southwestern part of Istria is built of Mesozoic carbonate sediments. The oldest rocks, situated between Rovinj and Poreč, belong to the Kimmeridgian. Cretaceous sediments are represented mostly by limestones, and to a lesser extent by dolomites. Their overall depth is more than 3000 m. It was during the Upper Senonian time that the regression and Laramide orogenic movements set out. The raised carbonate terrain was subjected to intensive erosion and peneplanation. Considerable bauxite deposits were formed at that time (Fig. 1).

The emergence phase lasted till the Early Eocene epoch when transgression set out from the northeast. The region, where the bauxite deposits are located on the surface at present, was subjected to the transgression during Mid-

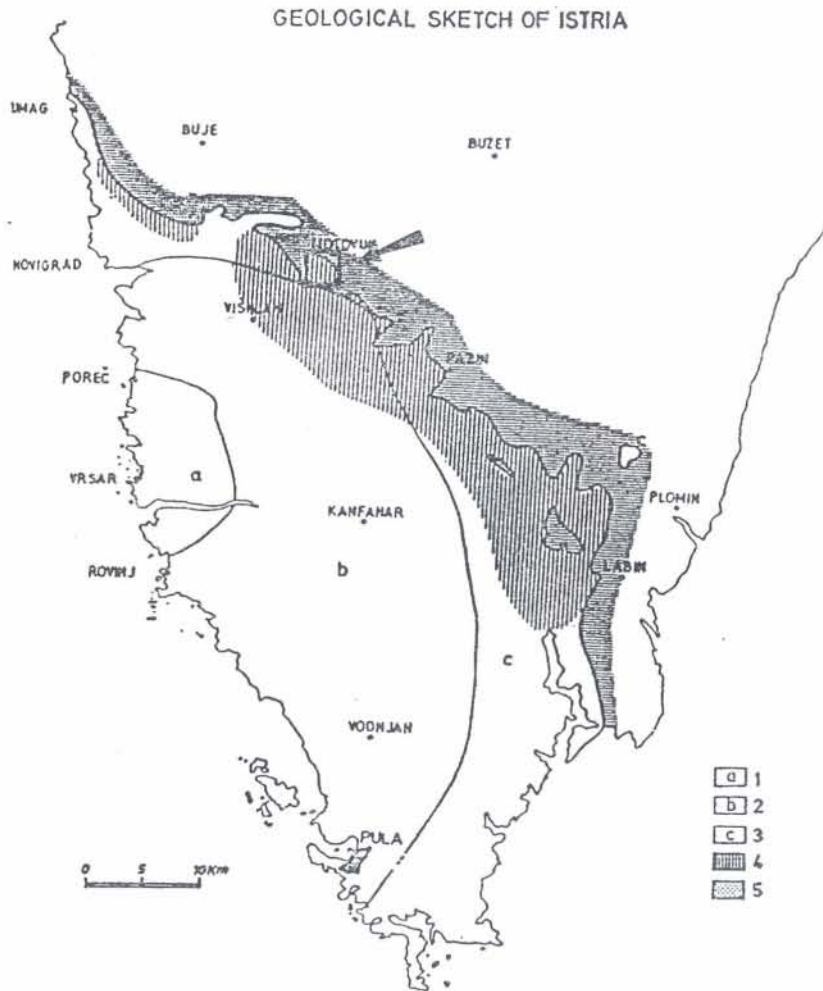

Fig. 1  
 Geological sketch of Istria. According to Polšak (1965) and Šikić and Polšak (1963)  
 1. Malm. 2. Lower Cretaceous. 3. Upper Cretaceous. 4. Bauxite bearing area. 5. Eocene. 6. Area of investigation

dle and Upper Cuisian time (Drobne, 1971). Fresh water and brackish sediments with coals (Liburnian deposits) sedimented in isolated basin in succession. They were followed by marine sedimentation, foraminiferal limestones and flysch. The sediments of the Lower Eocene lie over the Cretaceous strata of different age with pronounced erosional discordance, while angular unconformity is inconspicuous. The geographical position of the object of geochemical survey is presented in Fig. 2.

### Bauxite deposits

The bauxite bearing area in Istria extends along the Cretaceous-Paleogene border from Umag in the NW Istria to Labin in the SE. This is a stretch, some 60 km long and 4 to 6 km wide, where most of the bauxite deposits are located (Fig. 1). The deposits are found on the Cretaceous carbonate rocks exclusively. The oldest footwall rocks are situated near Višnjan and belong to the Albian, while the youngest ones are near Labin and of the Turonian age. Microsparites prevail in the footwall limesto-

nes, but intrasparites, micrites and dismicrites can also be found. Limestones often contain macrofossils.

In majority of the bauxite deposits the Eocene roofwall sediments were completely eroded, so the bauxite is covered by terra rossa. Part of the deposits is overlain by the Lower Eocene limestones and marls. Certain deposits are covered by clay intercalated with coal material. The roofwall sediments are often concavely bent above the deposit, lowered tens of meter, owing to postdiagenetic compaction of the bauxite.

Bauxite ore bodies are usually small, conical in shape, formed by filling of karst funnels (Šinkovec, 1973, Fig. 3). The surface area of the outcrops is mostly 100 to 300 m, the depth being 8 to 30 m, rarely 45 m. In respect to distribution of the deposits no regularity has been observed, except that their number and size are larger in the vicinity of the Cretaceous-Paleogene border. Ten to ninety bauxite deposits are located per square km.

Bauxite is mostly red in color. The upper and lower parts of the deposits are usually yellow due to transition of hematite to goethite. In

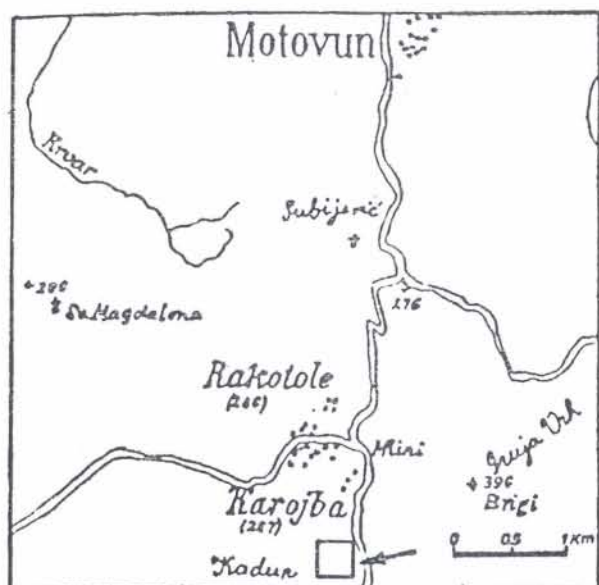

Fig. 2 Precise position of the investigated area

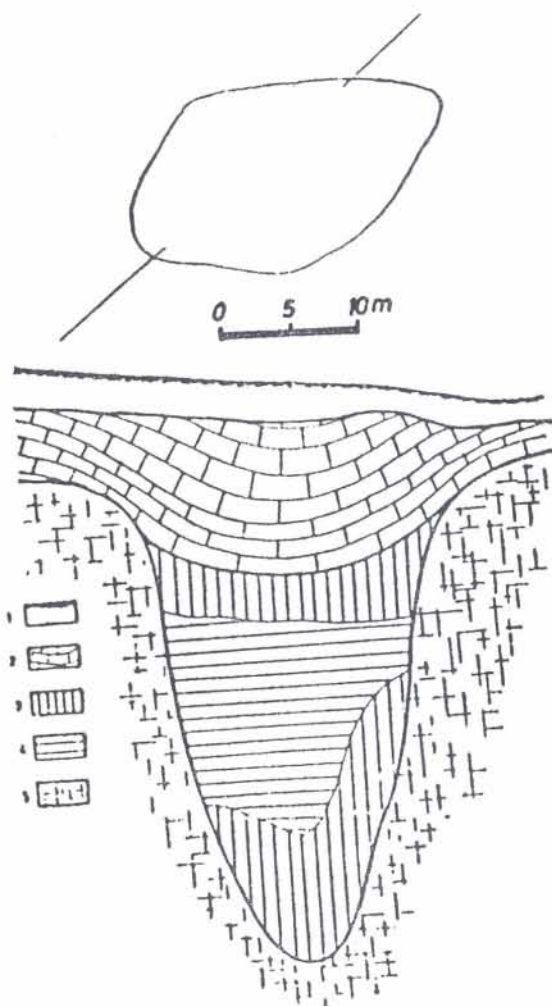

Fig. 3 Typical Paleogene bauxite deposit

1. Quaternary.
2. Eocene limestones.
3. Yellow bauxite.
4. Red bauxite.
5. Upper Cretaceous limestones

some deposits pyrite occurs instead of hematite and consequently bauxite is gray. Pyritized bauxite never fills the whole deposit, but it is found in irregular bodies in the red bauxites.

The texture of the bauxites is roundgrain, rarely oolite. Oolites and round grains with diameters usually under 0.5 mm are found in the cryptocrystalline matrix. Mean chemical composition of Istrian bauxites with deposits of high kaolinite content taken into account is:  $Al_2O_3 = 54.28\%$ ,  $Fe_2O_3 = 21.88\%$ ,  $SiO_2 = 5.93\%$ ,  $TiO_2 = 3.18\%$ , L.O.I. = 14.00% (Šinkovec, 1973). The deposits of high quality are often located in the neighbourhood of the kaolinite-rich ones and no regularity has been noticed in their spatial lay-out. The mineral composition of an average Istrian bauxite is: boehmite is the main mineral, kaolinite varies between 1% to 20%, gibbsite is present in some deposits, but in inconsiderable quantities, anatase is more often than rutile, pyrite and marcasite are present only in pyritic bauxites, goethite was formed by weathering of hematite and pyrite. Accessory, detrital minerals, zircon, apatite, tourmaline and garnet are very rare.

### Geochemical survey

Search for »blinde« bauxite ore body by secondary geochemical dispersion halo was the main task which governed the way of sampling and analytical procedure. Bauxite, as a typical hydrolisate formation, passing through an early colloidal stage efficiently accumulates metal cations. Accumulation mechanism ranges from simple coprecipitation of tri- and higher-valence elements, but very efficient is also colloidal sorbtion of divalent, otherwise chalcophile cations (heavy metals, Palinkaš, 1986, 1987).

In order to recheck that well known geochemical fact we analyzed 4 samples of typical Istrian bauxites (Table 1). B1 and B2 are red bauxites, B3 yellow and B4 pyritic. In comparison to an average terra rossa sample taken close to the blinde ore body, there is an obvious multi-fold increase of cadmium, cooper, zinc, and lead concentration. Surprisingly low content of chalcophile elements in pyritic bauxite has already been observed in pyrite-bearing (early diagenetic) Permian shales and sandstones (Palinkaš, 1988). With a presumption that the simple geology and geometry of the ore bodies, covered by terra rossa or an Eocene sedimentary cap, might be a convenient site for development of distinctive secondary heavy metal halo, we sampled terra rossa over blinde ore bodies and barren terra rossa and forest gray soil in the immediate neighbourhood for comparison.

Soil sampling at a distance of several meters, was followed by measurements of relative concentration of mercury in air (recorded in mA)

Table 1  
Content of trace element in some bauxite samples  
(leaching by  $\text{HNO}_3$  :  $\text{HCl}$ , [1 : 3] conc.)

in ppm	Hg	Cd	Cu	Pb	Zn	Mn	Co
B1 red bauxite	0.42	1.66	138	88	208	683	4
B2 red bauxite	0.40	1.25	163	106	291	416	7
B3 yellow bauxite	—	0.66	563	100	375	708	12
B4 pyritic bauxite	0.13	0.08	125	44	50	—	45,3

by mercury vapor analyser. Investigated ore bodies were Karojba L-650 (grassland, close to arable land, Fig. 6), Karojba L-65 (forest, Fig. 7), Karojba L-57 (grassland, Fig. 8), Karojba L-587 (ploughland, Fig. 9). In addition, sampling of soil, along a traverse on barren terrain, close to bauxite bearing area, was performed as well. The Profile I was on arable land, the Profile II on grassland and the Profile III in forest.

### Analytical procedure

#### Mercury in air — Zeeman atomic absorption mercury vapor analyser

Measurements of mercury vapor contamination in atmosphere, including background level, has been performed by Zeeman atomic absorption mercury vapor analyser. A prototype of the instrument, used in fieldwork was constructed in the Institut of the Earth crust, Leningrad State University by Sveshnikov et al. (1980). It operates on a base of differential absorption method using the Zeeman effect and the isotopic splitting effect of the mercury spectral line at 253,7 nm wavelength. Light source is a mercury lamp filled by isotope 204, situated in stable magnetic field. It causes differentiation of mercury resonance line into 3 components,  $\pi$ -component, linearly polarized in a plane, parallel to the magnetic field, and two  $\sigma$ -components having circular polarization.  $\pi$ -component is not effected in relation to the standard line, but  $\sigma$ -components are shifted for  $\Delta\nu = \pm 0.07 B$  whereas B is the magnetic field induction. Sufficiently strong magnetic field changes  $\sigma$ -component enough not to be absorbed by mercury. Constant intensity of  $\sigma$ -component controlled by automatic voltage regulation enables simple relationship between mercury concentration and intensity of receiving light,  $N = \text{const} \cdot (I\sigma - I\pi)$ , since wavelength of  $\pi$ - and  $\sigma$ -components are practically equal and non-selective absorbance are almost the same for both components. Measured mercury vapor concentrations ranges from 10—10000 ng/m<sup>3</sup>. The data were displayed, and read, however, on an analogue meter in mA.

#### Mercury in soil — Flameless atomic absorption method

Conventional atomic absorption techniques are not ideal for the mercury determination as sensitivity shown by this element is poor (around 5ppm). Metallic mercury exist in the atomic vapour form at ambient temperatures and thus high temperature flames are not necessary for its measurements by atomic absorption techniques. Provided mercury is present in vapour form, a simple silica cell may be used to circulate mercury atoms in the beam of mercury hollow cathode lamp for atomic absorption measurements. Pye-Unicam mercury vapor analyser kit used for determination of mercury in soil is presented in Fig. 4.

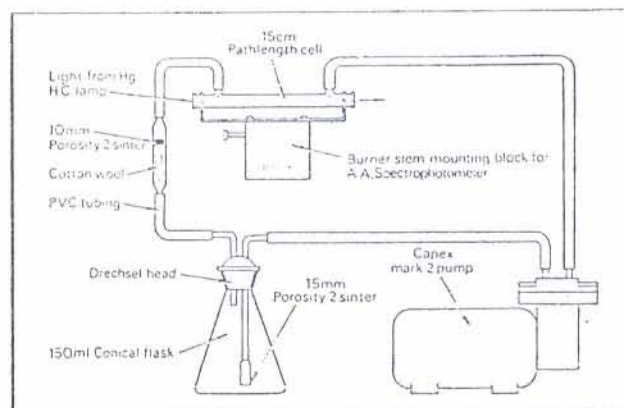

Fig. 4 Scheme of the flameless mercury atomic absorption kit

Each soil sample, weighed 1.0000 g, was digested in 15 ml  $\text{HNO}_3$  :  $\text{HCl}$  (1 : 3) acid mixture, at 70 °C for 6 hours. After digestion, the mixture was cooled to room temperature, diluted to 50 ml by distilled water. Excess of oxidizing acid mixture was reduced by hydroxylaminhydrochloride. Stannous chloride solution was added to reduce mercury ions into elementary mercury, which was swept by an air stream through the absorption cell of the atomic absorption spectrophotometer. The absorption were measured by peak height, and compared with a calibration curve (Fig. 5). All reagents

CALIBRATION LINE FOR MERCURY

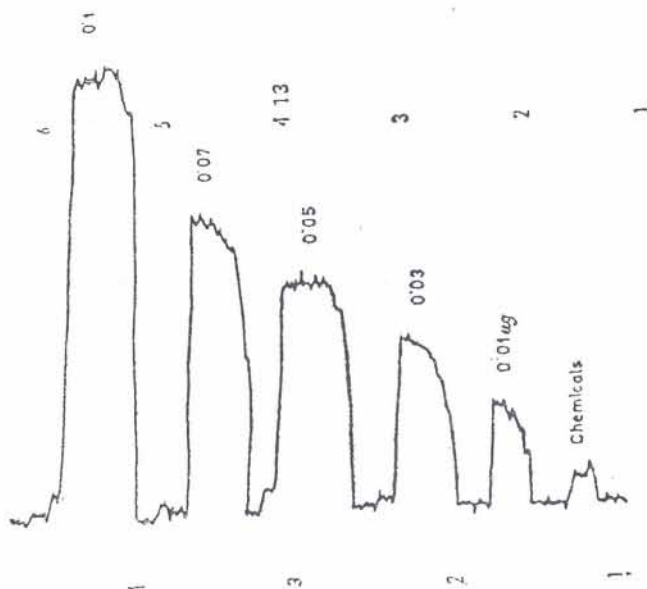
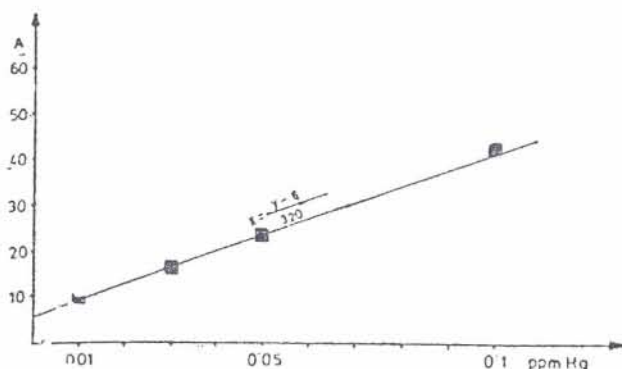

Fig. 5 Set of standard concentration values (scale 1 : 2)

contained mercury, so the measurements values were rectified for that chemical contamination.

Reagents:

- HNO<sub>3</sub> : HCl (1 : 3) conc.
- SnCl<sub>2</sub> · H<sub>2</sub>O (10% wt. solution)
- Hydroxylamin-hydrochloride (20% wt. solution)
- Hg(NO<sub>3</sub>)<sub>2</sub> standard solution in dil. HNO<sub>3</sub>-HCl

Instrument conditions:

- lamp current 5 mA
- wavelength 253.7 nm
- band pass 0.5
- damping 0.5 s
- scale expansion 0
- speed of record. 0.3 mm/min
- recorder range 2 mV

Table 2

Content of trace elements in terra rossa on the ore-bearing terrains (leaching by HNO<sub>3</sub> : HCl [1 : 3] conc.)

Ore body L-650							
	Hg	Cd	Cu	Zn	Co	Pb	Mn
1	0.75	0.75	46	53	3	45	694
2	0.76	0.46	28	84	7	44	721
3	0.63	0.28	18	84	6	56	896
4	0.64	0.21	18	50	7	42	605
5	0.94	0.50	30	68	14	46	896
6	0.70	0.15	26	53	16	45	1106
7	0.82	0.06	22	38	15	37	973
8	0.74	0.06	55	40	17	48	1068

Ore body L-65							
	Hg	Cd	Cu	Zn	Co	Pb	Mn
1	0.69	0.09	28	53	17	41	819
2	0.64	0.20	20	50	16	43	718
3	0.68	0.0	32	44	15	43	733
4	0.64	0.13	24	53	15	46	441
5	0.54	0.0	18	44	16	41	508
6	0.60	0.06	20	44	15	39	596
7	0.56	0.06	24	44	15	33	470
8	0.68	0.25	24	50	16	41	1026
9	0.64	0.09	36	56	15	43	605
10	0.66	0.15	32	50	15	41	694
11	0.64	0.07	30	53	15	46	694
12	0.64	0.18	28	56	15	39	860

Ore body L-57							
	Hg	Cd	Cu	Zn	Co	Pb	Mn
1	0.74	0.34	26	56	16	34	1042
2	0.60	0.25	24	53	16	39	957
3	0.67	0.34	26	56	13	37	654
4	0.67	0.22	23	53	15	38	967
5	0.74	0.21	24	50	13	38	743
6	0.72	0.21	26	53	14	37	753
7	0.64	0.43	22	53	16	35	958
8	0.68	0.41	26	59	16	44	963
9	0.71	0.30	26	50	13	39	844
10	0.71	0.28	26	50	15	37	895
11	0.60	0.21	28	50	15	36	947
12	0.64	0.21	28	50	15	37	989
13	0.65	0.09	28	50	15	37	951
14	0.63	0.40	28	53	15	37	1143
15	0.64	0.34	30	53	14	36	1084
16	0.67	0.43	30	65	15	37	1214
17	0.64	0.34	26	53	16	35	1133
18	0.63	0.37	32	59	16	36	1170

Ore body L-587							
	Hg	Cd	Cu	Zn	Co	Pb	Mn
1	0.57	0.06	32	47	16	37	1079
3	0.53	0.03	28	44	18	36	1170
5	0.53	0.0	24	41	18	35	1106
7	0.98	0.09	26	44	20	37	1187
9	0.72	0.13	26	47	22	37	1187
11	0.55	0.09	24	41	19	36	1154
13	0.56	0.09	20	41	15	34	937
14	0.56	0.06	22	47	19	39	1214
16	0.57	0.03	28	50	22	43	1412
18	0.57	0.03	24	41	12	36	1214
20	0.57	0.03	22	41	18	36	1160
22	0.53	0.0	20	38	18	36	1079
24	0.60	0.09	24	44	19	37	1095
26	0.60	0.0	20	38	17	36	1047
Mean	0.65	0.19	27	51	15	39	936
Stand. dev.	0.09	0.16	6	9	3	4	224
Numb. of sampl.	= 52						

Table 3

Average content of trace elements in soil on the barren terrains

(leaching by HNO<sub>3</sub> : HCl [1 : 3] conc.)

		Profile I ploughland n = 19	Profile II grassland n = 12	Profile III forest n = 14
Hg	mean	0.53	0.57	0.71
	st. dev.	0.10	0.06	0.09
Cd	mean	0.09	0.10	0.41
	st. dev.	0.07	0.06	0.15
Cu	mean	30	28	21
	st. dev.	4	4	4
Zn	mean	36	36	35
	st. dev.	3	3	3
Co	mean	16	13	14
	st. dev.	1	2	2.5
Pb	mean	39	38	37
	st. dev.	5	6	5
Mn	mean	1179	907	1031
	st. dev.	112	269	205

### Statistics

Concentration of trace elements Hg, Cd, Cu, Zn, Co and Mn in terra rossa are given in Table 2, and plotted on Fig. 6, 7, 8 and 9. The relative value of mercury in air has been plotted as H' on the same plots. Data from the barren Profiles I, II, and III are presented in Table 3 and Fig. 10. Frequency distribution for Hg, Cd, Cu, Zn, Co and Pb are shown on Fig. 11. Mean values and standard deviations for the same element population are shown in Table 2. Correlation matrices for trace element population and horizontal distance between the sampling site and the ore body underneath DH, are given in Fig. 12. Correlation matrices for the barren Profile I, II and III are presented in the same Fig. 12. Cluster analysis of correlation matrices for L-650, L-65, L-57, L-587 and displayed in Fig. 12, are given in Fig. 13. Discriminant analysis of ore bearing and barren sample population gave following data, Mahalanobis value  $D2 = -3.94$ ,  $R1 = -2.1111$ ,  $R0 = -0.1422$ ,  $R2 = -1.8268$ . Positive scoring for the barren group of data was 76% and for the ore-bearing one 75%.

### Discussion

The primary goal of the investigation was search for distinctive secondary halo in terra rossa above the bauxite bodies. The expectation was based on significant difference in geochemistry of the bauxite, carbonate host rocks, terra rossa and soil (Table 1 and 2). After statistical procedure and plotting of data along the investigation traverses certain regu-

larity appeared to be distinguishable. Although interpretation on relatively small number of measurements, in highly variable conditions (regarding preservation of natural soil profile) might be in some way speculative.

The terra rossa profiles over the ore ranges from the highly disturbed one (plough land), L-587, to moderately disturbed (grassland, with uncertain agricultural history L-650 and L-57, and naturally preserved (forest) L-65. The profiles over the barren terrain, close to the investigated ore bearing one and similar, Profile I is ploughland, Profile II grassland and Profile III forest.

It is significantly reflected in statistics of trace elements. L-587, ploughland and Profile I (Fig. 9, Fig. 10) have the smoothest line of concentration values along the sampling traverse due to intensive yearly homogenization (ploughing). This is also noticeable in small standard deviations of trace element population (Table 2). Fluctuation of the values in L-57 and L-650 traverses, and Profile II (grassland at present, but agricultural history is uncertain, Fig. 6, Fig. 8, Fig. 10) is more intensive and in case of L-65 and Profile III (forest) this feature is even more expressed (Fig. 7, Fig. 10).

Clustering of correlation matrices (Fig. 12) gives another illustration of that process. L-65 (forest) cluster shows fairly good connection of all trace elements and influence of the distance from the ore body DH. In contrary, L-587 (ploughland) cluster has unrelated value of DH and poorly connected trace elements. Situation with L-57 and L-650 clusters is in between. The behavior of trace elements will not be discussed in detail, since lack of other relevant data, with exception for mercury.

### Mercury

An analytical survey of mercury in 912 samples of soil taken through the United States showed levels ranging from 0.055 ppm to 46 ppm, with a geometric mean of 0.071 ppm (Shacklette et al., 1971, cited in Bache et al., 1973). In some Norwegian soils concentration was between 0.070 and 0.370 ppm (Lag and Steines, 1970, cited in Wimmer, 1974). In 273 Swedish soils, an average of 0.060 ppm was determined (Wimmer, 1974). Cropland contains more Hg than noncropland soils in average. The natural presence of mercury in the earth crust is responsible for widespread traces of mercury in the environment. It causes difficulties in distinguishing mercury contamination from background levels. Contamination in agricultural soil is mostly because of application of fungicides, pesticides and fertilizers, but other sources are possible as well (Bache et al., 1973).

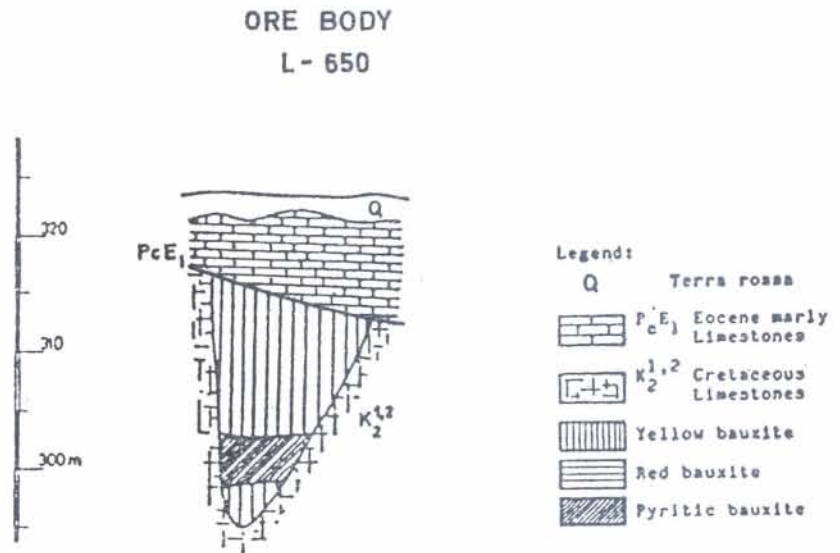

FLOUGHLAND

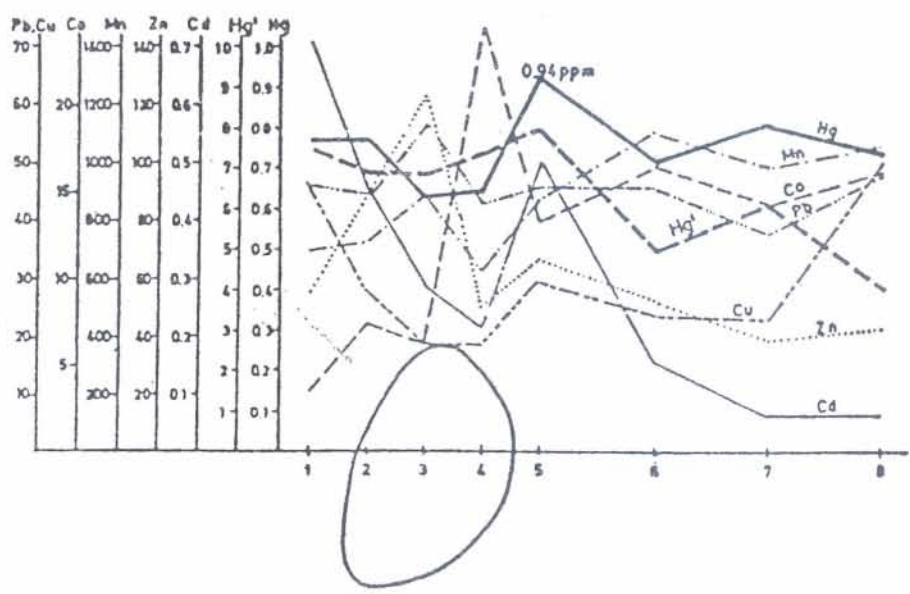
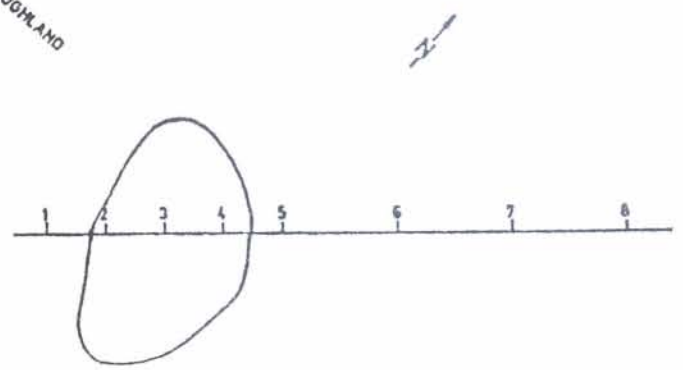

Fig. 6  
Geochemical profiles over  
the ore body L-650  
H' is mercury in air (mA),  
H is mercury in soil (ppm)

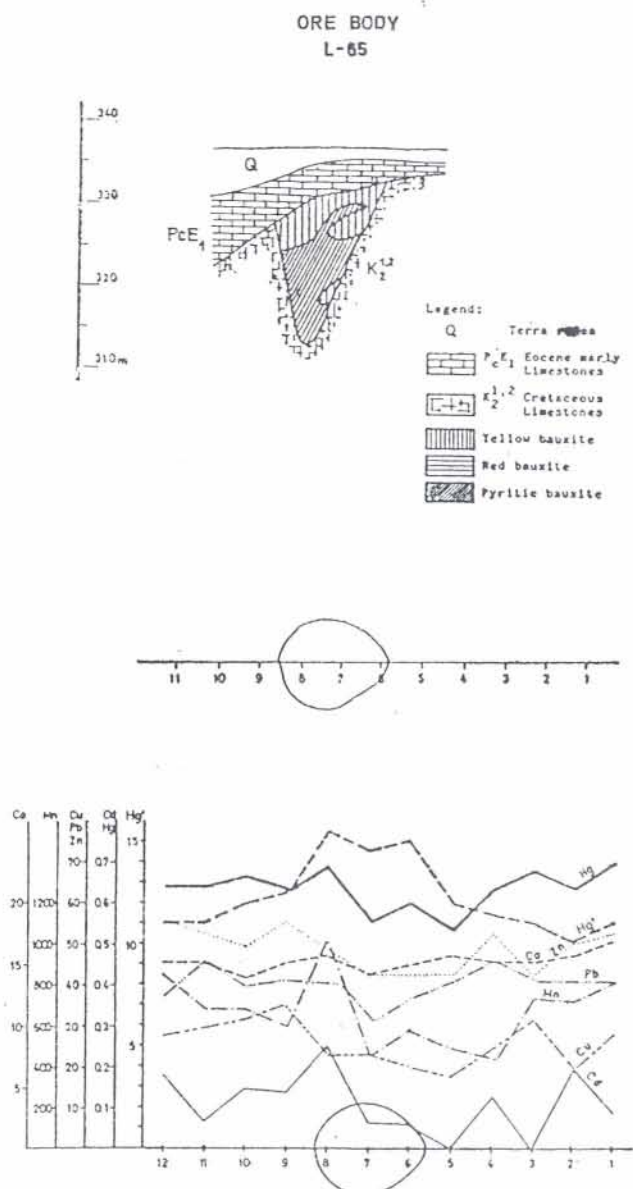

Fig. 7  
Geochemical profiles over the ore body L-65

Concentration of mercury in soil is directly correlated with quantity of humus and clayey fraction (Anderson and Winklander, 1965, cited in Wimmer, 1974). Organic matter is the main Hg-acceptor at lower pH, increasing pH-values facilitate adsorption of mercury on clay minerals, but at pH between 6 and 7, colloidal sesquioxides may play important role. Higher content of Hg in terra rossa between 0.310 ppm and 0.980 ppm might be explained by higher pH values in soil due to carbonate substratum. Mean value in all terra rossa samples  $\bar{x} = 0,653$ , and standard deviations is 0.091 (Table 2). The anomalous values, which might be used to recognize a blind ore body ( $\bar{x} + 2\sigma$ ) is 0.94, found in L-650 and 0.98 in L-587. Contrast of anomaly; A/T, whereas A is

anomalous concentration and T is threshold value (0.835), however is very low (1.13 and 1.17).

Another interesting phenomenon is a better correlation between Hg in air (expressed in relative values of mA) and Hg in soil over the deposit L-587 ( $r = 0.65$ ), a worse in L-650 ( $r = 0.42$ ), and no correlation is found in L-65 ( $r = 0.29$ ) and L-57 ( $r = 0.04$ ). As a matter of fact, there is better visual concordance of mercury in soil and air than statistics expressed through correlation coefficients. The reason for that might be influence of an undetermined factor (Figs. 6, 7, 8, 9), f. e. wind or moisture (Fursov, 1977, cited in Shorokov and Vostroknutov, 1980), which might give different trends to the profiles of mercury in air and soil regression line. It should be mentioned, however, that there are many other natural and manmade introductions of mercury into the terrestrial environment. The fate of this mercury is not fully understood. Mercury in air is also partly due to methylation process. It is affected by soil texture, soil moisture content, soil temperature and concentration of ionic mercury amendment (Rogers, 1976). Methylmercury is a product of aerobic as well as anaerobic metabolism of microbial cultures (Rogers, 1976, Bache et al., 1973).

This problem extends the scope of the subject. Our survey has been focused on probable connection of mercury content in soil and air, which might be used as an indicator of a blind ore body. The results are equivocal but worth to be rechecked by greater number of traverses and measurements, distinguishing statistically different environments regarding land use. Homogenization of trace element concentration caused by ploughing seems to be useful in recognition of mercury anomalies, which persist to stay expressed in contrast to the other elements (Fig. 9). There should be mentioned, however, that traverses might be too short laterally to record efficiently variations on barren and ore bearing ground., as noted by dr. N. Ozerova (during her visit to the Zagreb University). The data on mercury content in terra rossa and soil in Istria are informative as well.

### Conclusion

Geochemical investigation of mercury in soil and air, and trace elements in ore bearing and barren terrain by means of regular sampling along traverses has shown following results:

— the red, yellow and pyritic bauxites are sufficiently characterized by higher or lower trace element and mercury content in comparison to carbonate substratum or pedological formations (terra rossa and soil), to affect their surrounding and to cause formation of secondary geochemical halos,



ORE BODY  
L-57

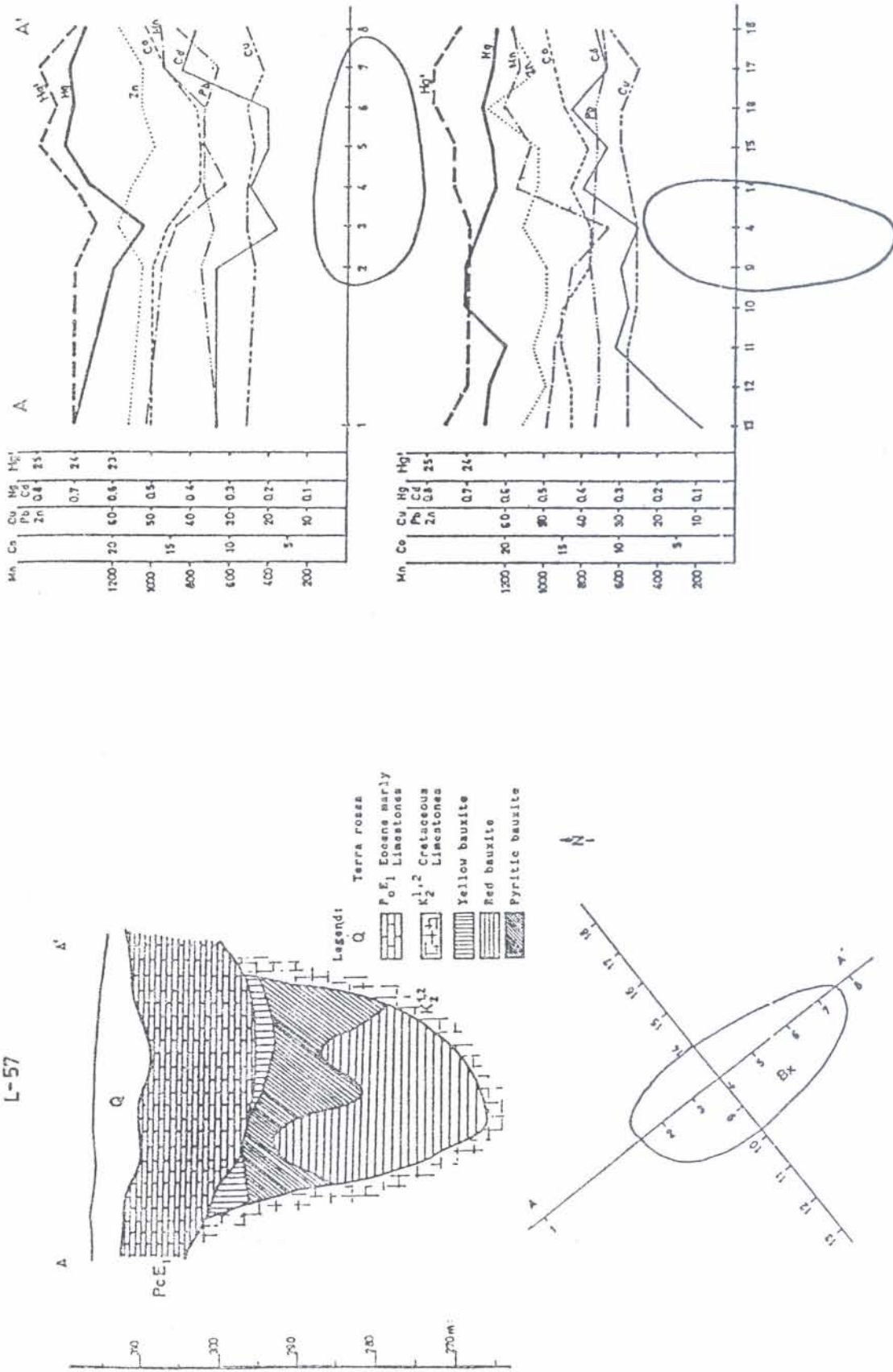

Fig. 8 Geochemical profiles over the ore body L-57

ORE BODY  
L-587

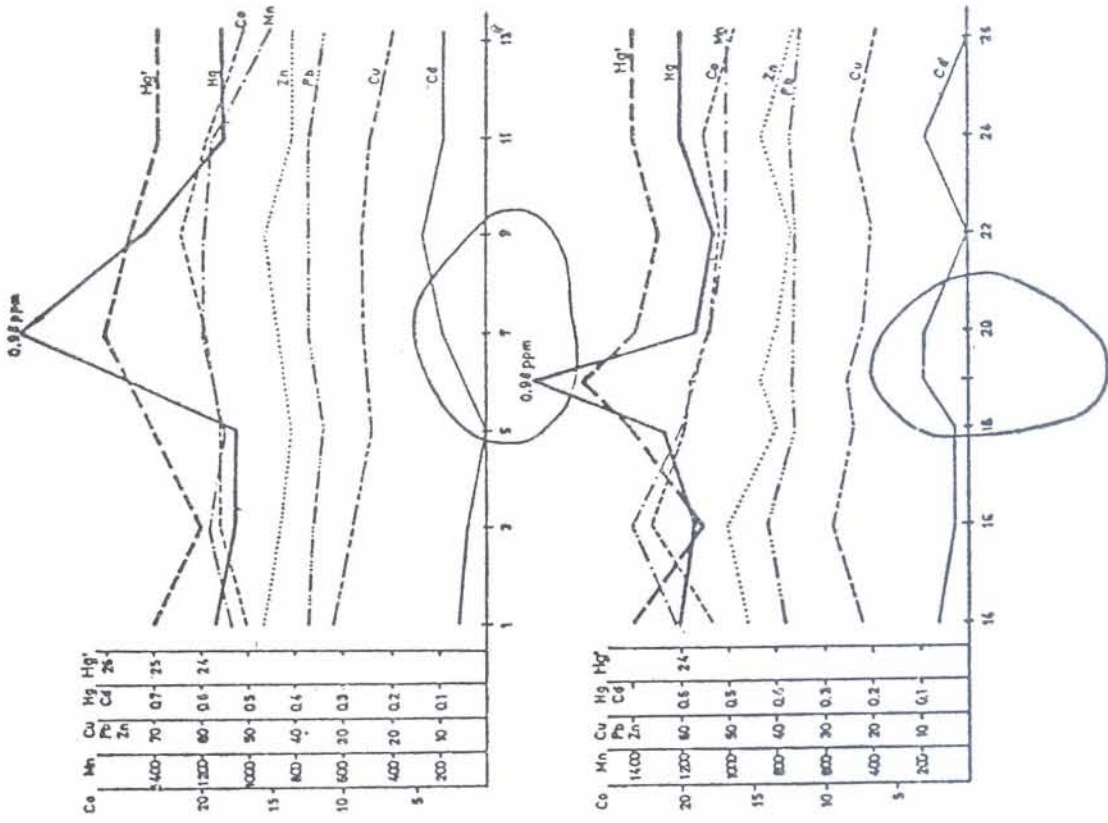
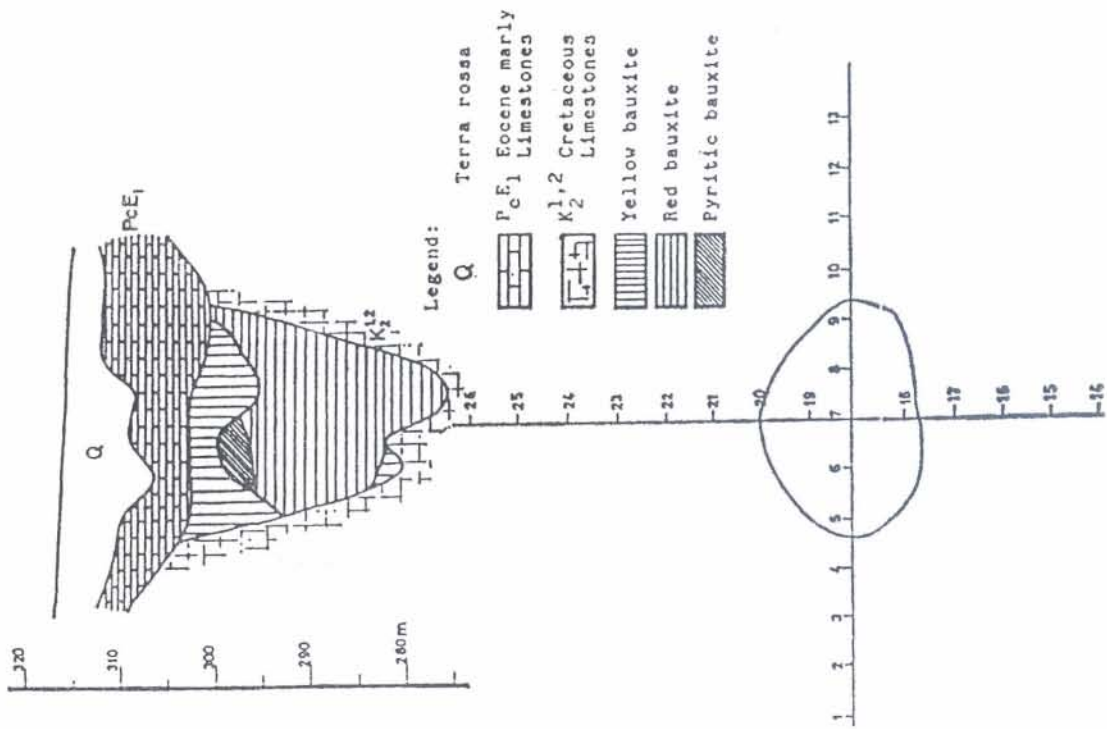

Fig. 9 Geochemical profiles over the ore body L-587

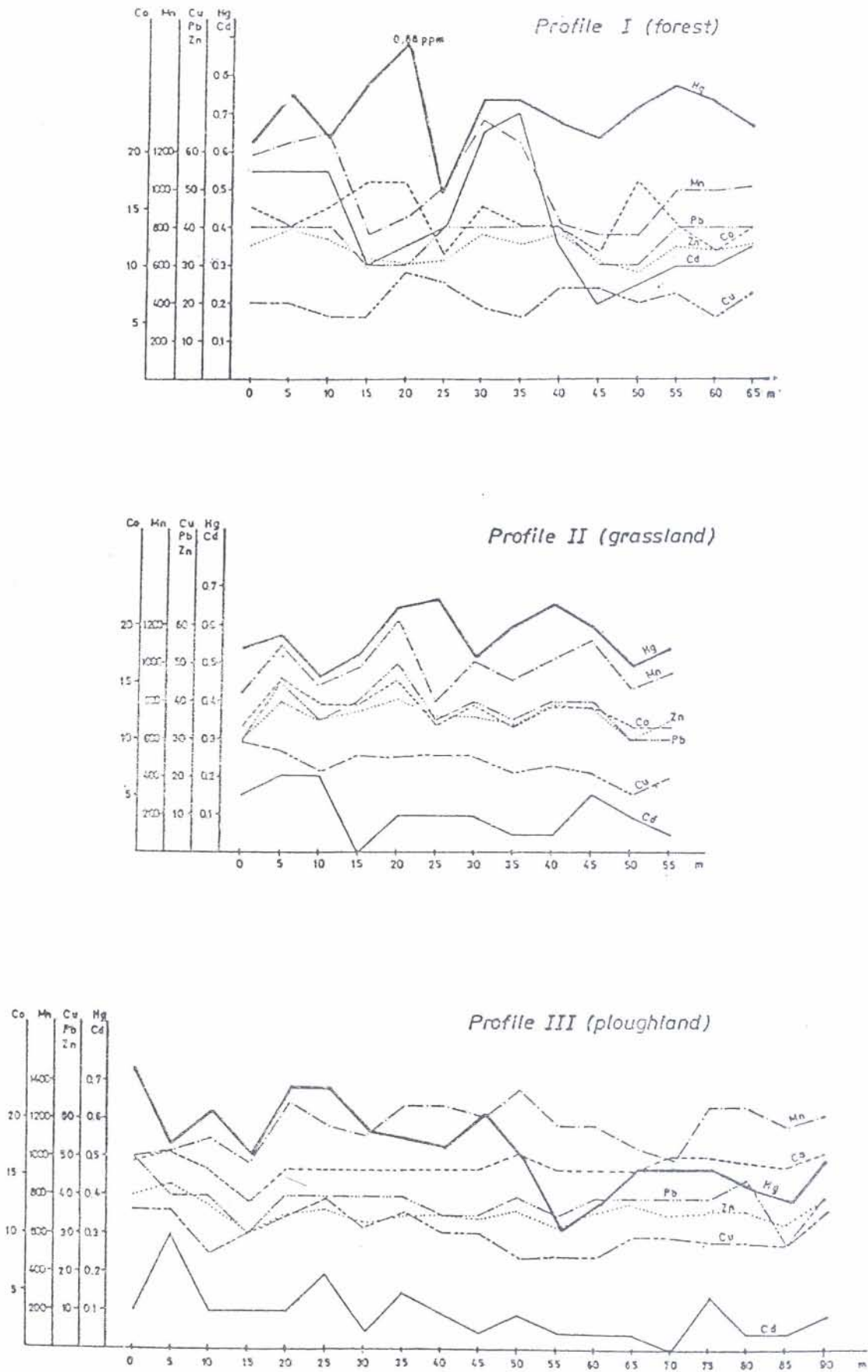

Fig. 10 Geochemical Profiles over the barren terrains

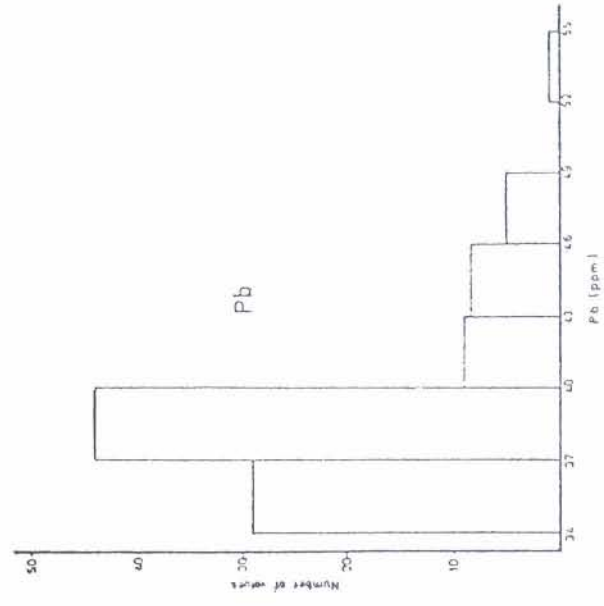
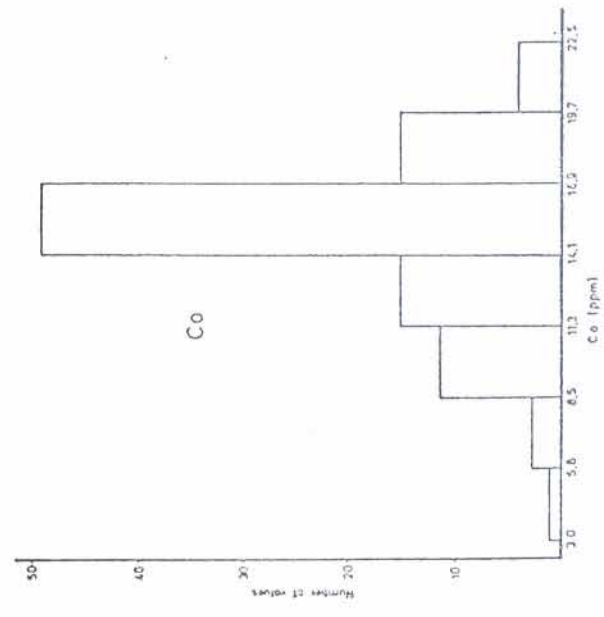
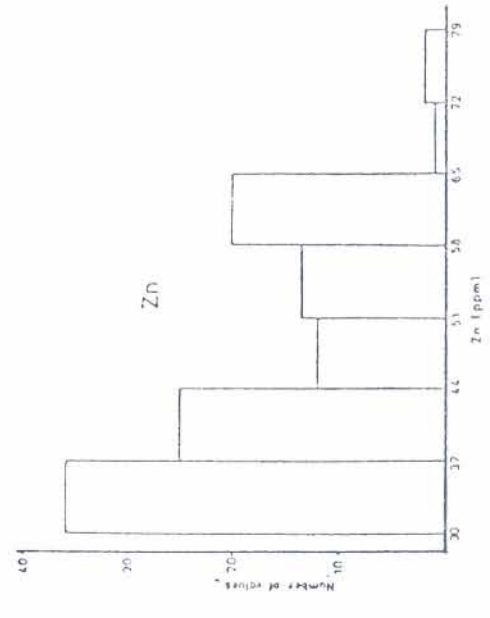
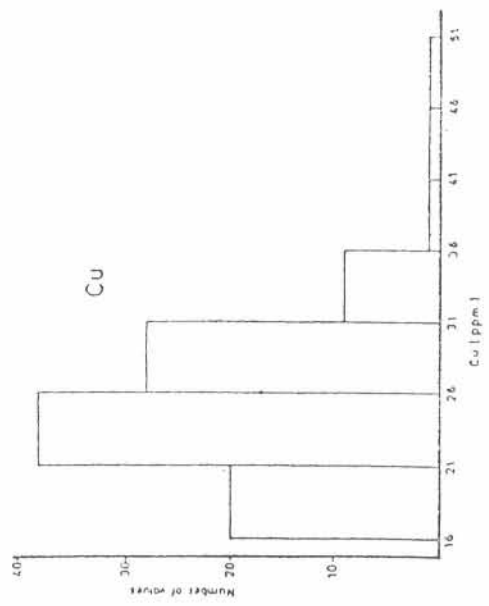
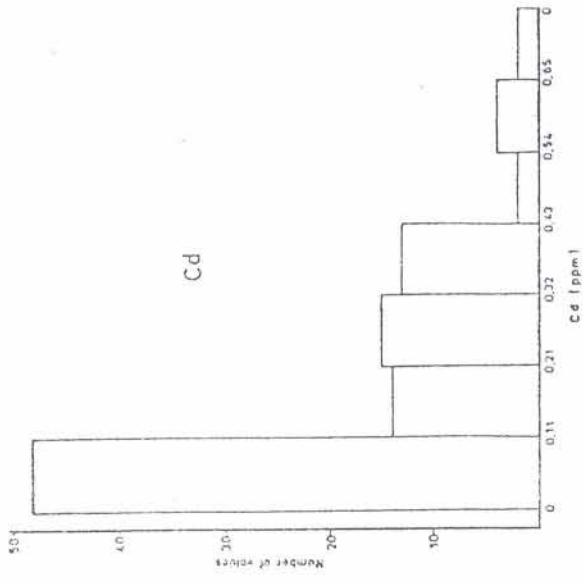
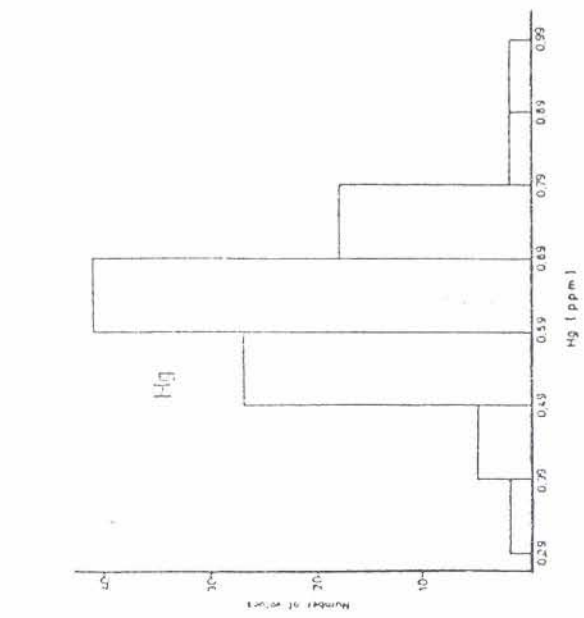

Fig. 11 Frequency distribution of trace elements population in the ore-bearing terrains

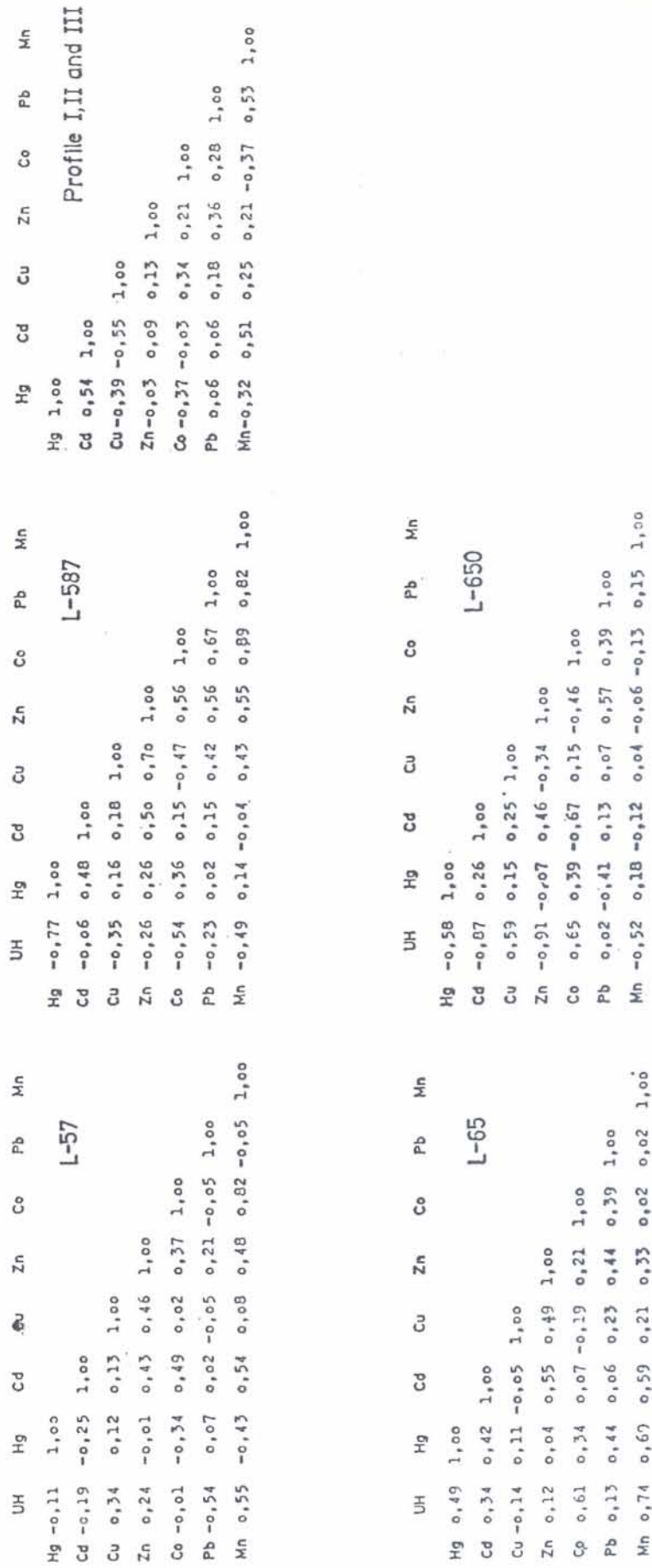

Fig. 12 Correlation coefficient matrices

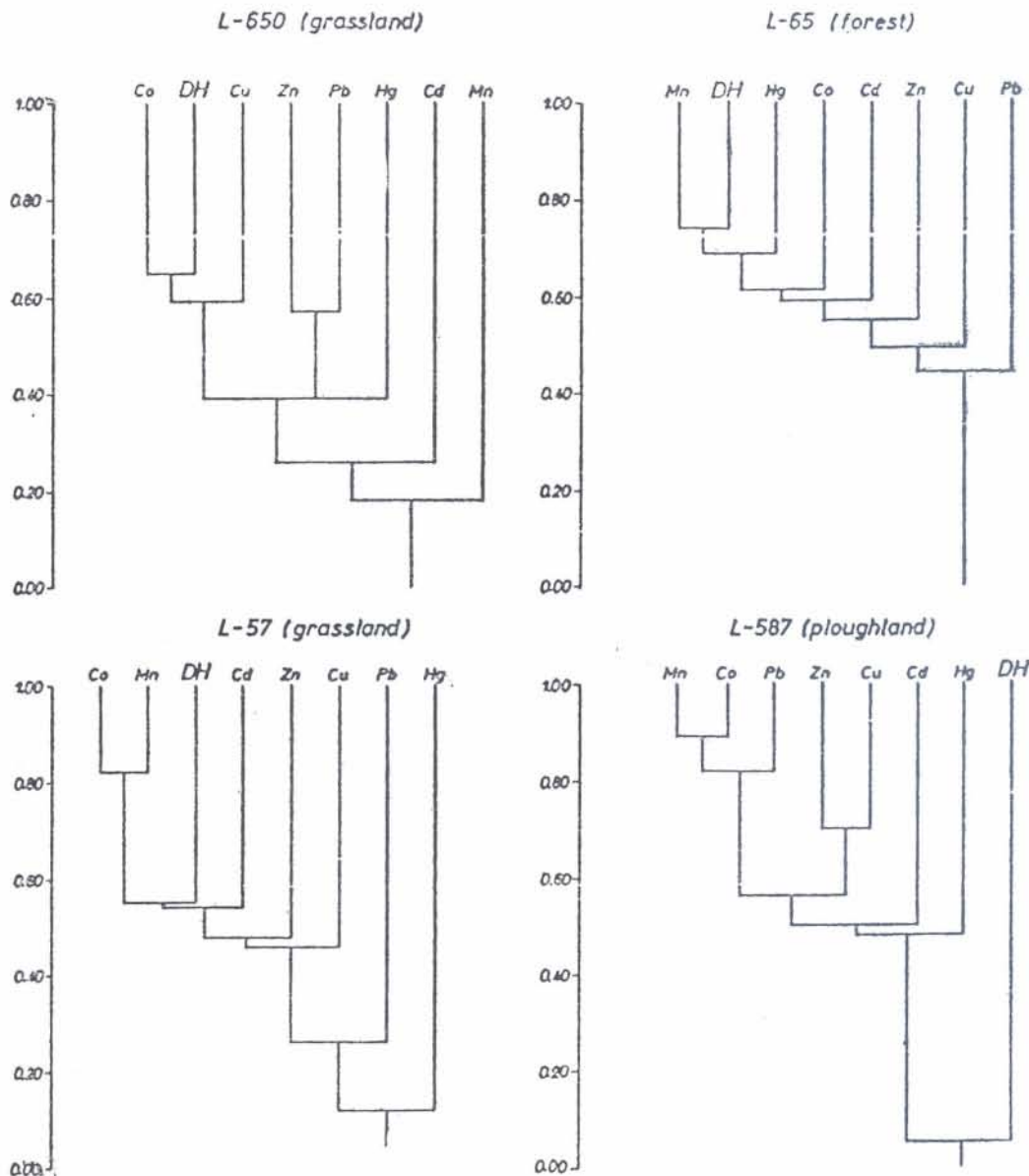

Fig. 13 Cluster analysis of correlation coefficients

— geochemical profiles along different traverses, regarding land use (forest, grassland, ploughland), show clear dependence i. e. different degree of soil profile disturbance or homogenization is evidently proven,

— terra rossa and gray soil in investigated area have higher content of mercury than some other type of soil on siliceous rocks, probably due to carbonate substratum (higher pH in soil),

— anomalous values of mercury over the ore deposits L-650 and L-587, distinguished by threshold value ( $\bar{x} + 2\sigma$ ) might be an indication of secondary halos but the contrast of anomalies is very low,

— synchronous fluctuations of mercury in terra rossa and air, visually recognized, is not

enough expressed by correlation coefficients ( $r = 0.65$ ), since some other undetermined factors cause different trends and spoil regression curve,

— discriminant analysis distinguished barren and ore bearing terrains but positive scoring was not to high (75 %).

Continuation of survey should rely on the preliminary results, which point out on great geochemical diversification of soil profiles regarding land use.

#### Acknowledgments

The authors express their gratitude to the management of »Istarski boksići« compa-

ny, Rovinj, for working permisison in the mine area. We are also thankful to ing. G. Rašović and ing. Mihovilović, who assisted measurements and organization of the field work. Some

comments of dr. Nina Ozerova are fully acknowledged. Thanks also go to ing. I. Opić for computer performance of discriminant analysis.

Primljeno: 9. I. 1989.

Prihvaćeno: 6. III. 1989.

#### REFERENCES

- Bache, C. A., Gutenmann, W. H., Leigh, E. St. J., Jr., Sweet, D. R., Hatfield, H. H. & Lisk, D. J. (1973): Mercury and Methylmercury Content of Agricultural Crops Grown on Soils Treated with Various Mercury Compounds. *J. Agr. Food Chem.*, 21/4, 607—613.
- Beus, A. A. & Grigorjan, S. V. (1975): Geohemičeskie metodi poiskov i razvedki mestorozhdenii tverdih poleznih iskopaemih. Nedra, pp. 278, Moskva.
- Drobne, K. (1971): Razvoj paleogenih alveolin v jugozahodni Sloveniji. — Thesis, University of Ljubljana. Ljubljana.
- Fursov, V. Z. (1970): Rtutnaja atmosfera rtutnih mestorozhdenii. *Dokl. AN SSSR*, 194/6, 209—211, Moskva.
- Fursov, V. Z. (1977): Rtut-indikator pri geokhimicheskikh poiskah rudnih mestorozhdenii. Nedra, Moskva (In: Fursov, 1980).
- Fursov, V. Z. (1980): Geokhimicheskie metodi poiskov glubokozalegajushchih rudnih mestorozhdenii. Nauka, pp. 20B, Novosibirsk.
- Hajratdinov, I. A. (1971): O gazovih oreolah rtuti. — *Geokhimiya*, 6, 668—683.
- Mc Carthy, J. H. (1973): Mercury vapor and other volatile components in the air as guide to ore deposits. *J. Geochem. Explor.*, 1/2, 143—162.
- Mesarić, Š. (1974): Određivanje žive metodom besplamene atomske apsorpcije. *Arh. hig. rada*, 25, 427—434, Zagreb.
- Ozerova, N. A. (1984): Geochemical peculiarities of mercury and mercury-bearing deposit formation. Proceedings of the Sixth Quadrennial IAGOD Symposium, Schweitzerbart'sche Verlag, Stuttgart.
- Ozerova, N. A. (1985): Source of basic ore-forming elements in the mercury-antimony deposits. *Geologicky Zbornik-Geologica Carpathica*, 36, 4, 414—419, Bratislava.
- Palinkaš, A. L. (1986): Geokemijsko istraživanje boksitonosti terena u području Jajca. Arch. Institute for geology and mineral raw materials, University of Zagreb.
- Palinkaš, A. L. (1987): Geokemijsko istraživanje stijena i boksita u rudniku boksita Jajce. Arch. Institute for geology and mineral raw materials, University of Zagreb.
- Palinkaš, A. L. (1988): Geochemical characteristics of the Paleozoic metallogenic regions, Samoborska gora, Gorski Kotar, Lika, Kordun and Banija. Thesis, pp. 128, University of Zagreb, Zagreb.
- Polšak, A. (1965): Geologija južne Istre s osobitim obzirom na biostratigrafiju gornjokrednih naslaga. *Geol. vjesnik*, 18/2, 415—509, Zagreb.
- Polšak, A. & Šikić, D. (1966): Tumač osnovne geološke karte list Rovinj. Savezni geološki zavod, Beograd.
- Rašković, G. (1979): Izbor metoda istraživanja paleocenskih ležišta boksita Istre i prikaz ostvarenih rezultata. Fond stručne dokumentacije »Istarskih boksita«, Rovinj.
- Rogers, R. D. (1976): Methylation of Mercury in Agricultural Soils. *J. Environ. Anal.*, 5/4, 454—458.
- Shorohov, G. P. & Vostroknutov, G. A. (1980): Gazortutni poiski glubokozalegajushchih mednokolchedanih mestorozhdenii na Urale. (In: Fursov ed., 1980).
- Šikić, D. & Polšak, A. (1963): Tumač osnovne geološke karte list Labin. Savezni geološki zavod, Beograd.
- Šinkovec, B. (1973): The Origin of Early Paleogene Bauxites of Istria, Yugoslavia. ICSOBA/3e congress, Nice, 151—164.
- Šinkovec, B. (1974): Porijeklo terra rossa Istre. *Geol. vjesnik*, 27, 227—237, Zagreb.
- Šinkovec, B. (1976): Sadržaj nekih mikroelemenata u boksitima SR Hrvatske. IV jugoslavenski simpozijum o istraživanju i eksploataciji boksita, Herceg Novi, 1976.
- Sveshnikov, G. B., Turkin, J. I., Aljtman, E. L., Mashjakov, N. R. & Sholupov, S. E. (1980): Aparatura dlja distancionnogo atomno-absorbcionnogo spektraljnogo analiza parov rtuti v atmosfere. (In: Fursov, 1980).
- Tišljaj, J. (1978): Tidal flat, lagoonal and shallow marine carbonate sediments in the Upper Jurassic and Cretaceous of Istria (Yugoslavia). *Acta Geol.*, IX/5 (*Prir. istr. Jugosl. akad. znan. umjet.*, 42), 159—194, Zagreb.
- Wimmer, J. (1974): Quecksilber in der Umwelt. *Die Bodenkultur*, 25/3, 273—290, Wien.

## Živa u tlu i zraku kao element-indikator za boksitna ležišta u Istri — eksperimentalni istraživački model

L. A. Palinkaš, S. E. Sholupov, B. Šinkovec, S. Miko, T. Sesvečan

Dugogodišnja tradicija geofizičkih istraživanja istarskih ležišta boksita nastavljena je uporabom Zeemanovog analizatora živinih para u atmosferi u kombinaciji s geokemijom zemlje crvenice iznad rudnih tijela. Živa u tlu određivana je besplamenom tehnikom atomske apsorpcije a Cd, Pb, Zn, Cu i Mn standardnom AA metodom. Uzorkovanje tla i mjerenje žive u zraku izvršeno je uzduž traversi preko četiri boksitna rudna tijela prekrivena eocenskom kapom, Karojba: L-65, L-650, L-57, L-587, i tri profila na neorudnjenom terenu radi komparacije geokemijskih podataka. Istraživana zemljišta koriste se kao livada, oranica i šuma, što bitno utječe na izgled vertikalnog profila tla i njegov stupanj poremećenosti. Rezultati istraživanja mogu se sažeti u sljedeće zaključke:

- crveni, žuti i pirinitni boksiti su dovoljno geokemijski karakterizirani s povišenim ili sniženim sadržajem elemenata u tragovima u odnosu na karbonatni substrat ili pedološke tvorevine (zemlju crvenicu) da izazovu stvaranje sekundarnog geokemijskog aureola,
- geokemijski profili uzduž različitih traversi, s obzirom na način korištenja zemljišta (livada, orani-

ca, šuma), tj. različit stupanj poremećenja vertikalnog profila tla je bez dvojbe dokazan,

- zemlja crvenica u istraživanom području ima povišen sadržaj žive i nekih drugih elemenata u tragovima u odnosu na tla ležeća preko silikatnih stijena, vjerojatno zbog karbonatnog substrata (povišen pH u tlu),

- anomalne vrijednosti za živu iznad ležišta L-650 i L-587, prihvaćene po kriteriju  $\bar{x} + 2\sigma$ , mogle bi se uzeti kao indikacije sekundarnog haloa, ali je kontrast anomalije vrlo nizak,

- sinhrona fluktuacija žive u zemlji crvenici i zraku, vizualno uočena, nije dovoljno izražena kroz korelacione koeficijente ( $r = 0.65$ ), jer neki, za sada, ne utvrđen faktor kvazi regresionu krivulju uzrokujući različite trendove,

- diskriminantna analiza razlikuje orudnjene i neorudnjene terene uz efikasnost pogađanja od 76%.

Nastavak istraživanja trebao bi se oslanjati na ove preliminarnе rezultate, koji ukazuju na veliku diversifikaciju profila tla s obzirom na upotrebu zemljišta.