

## Application of the Kaiser Effect in In-situ Stress Measurement in Rocks - an overview

Rudarsko-geološko-naftni zbornik  
(The Mining-Geology-Petroleum Engineering Bulletin)  
UDC: 622.2  
DOI: 10.17794/rgn.2022.4.1

Preliminary communication



Mohammadmahdi Dinmohammadpour<sup>1</sup>; Majid Nikkhah<sup>2</sup>; Kamran Goshtasbi<sup>3</sup>; Kaveh Ahangari<sup>4</sup>

<sup>1</sup> Department of Mining Engineering, Science and Research Branch, Islamic Azad University, Tehran, Iran, ORCID <http://orcid.org/0000-0003-0573-2510>

<sup>2</sup> Faculty of Mining, Petroleum & Geophysics Engineering, Shahrood University of Technology, Shahrood, Iran, ORCID <http://orcid.org/0000-0002-5961-618X>

<sup>3</sup> Mining Engineering Department, Tarbiat Modares University, Tehran, Iran, ORCID <http://orcid.org/0000-0003-1202-3536>

<sup>4</sup> Department of Mining Engineering, Science and Research Branch, Islamic Azad University, Tehran, Iran, ORCID <http://orcid.org/0000-0001-9462-7303>

### Abstract

Knowledge of in-situ rock stress is one of the significant issues in many engineering problems. There are various methods for determining in-situ stress. Most of the common methods used for the determination of in-situ stress are time and cost consuming, and in many cases need specific accessibility. Therefore, attention to core-based methods is increasing. One of these methods is the acoustic emission technique based on the Kaiser effect. This method is among the stress stressing-destressing methods and is based on observing rock behaviour without having any important impact on it. Knowledge of the acoustic emission principles and acoustic signal parameters is the first step to use the Kaiser effect method for in-situ stress determination. Also, using the Kaiser effect method requires knowledge on the mechanism and theory associated with the Kaiser effect. In this research, different methods for determining the Kaiser effect in parametric (tangent method and maximum slope, etc.) and signal processing (Fourier transform, wavelet transform, etc.) terms were reviewed. The results obtained from the Kaiser effect method were compared to other common methods used for in-situ stress measurement, like over-coring and hydraulic fracturing methods, and based on the results, there was a good agreement between them. Also, the effective parameters on determining the Kaiser effect stress point were investigated. The important parameters were the testing procedure, confining pressure, physical properties of rock, delay time and retention time, direction and amount of loading, anisotropy angle and loading rate.

### Keywords:

in-situ stress; acoustic emission; Kaiser effect; signal processing; wavelet transform

## 1. Introduction

### 1.1. In-situ stress measurement methods

Knowledge of the in-situ stress in the Earth's crust is of great importance in many problems associated with civil, mining and petroleum engineering disciplines, and also geology and geophysics. It is quite clear that different technical and safety aspects in many civil and mining projects have a deep relationship with the stress measurement process in rocks. The data corresponding to in-situ stress is required for many engineering activities, directly or as input parameter for the numerical models. It should be noted that the Kaiser effect method can be used as an estimation method of in-situ stress and the authors of the present paper believe that more research is still needed on laboratory core based methods. The acoustic emission method based on the Kaiser effect

phenomenon is one of the methods for determining the in-situ stress. According to the different classifications, the Kaiser effect method is the one where a core drill is needed. In **Tables 1 to 3** the situation of the acoustic emission method based on the Kaiser effect is shown for different classifications of the in-situ stress determination methods. As seen in **Table 1**, in the first classification, two families of methods for in-situ stress determination in terms of their effect on the rock conditions are available (**Ljunggren et al., 2003**).

The second classification is based on the type of operation, and volume of the involved rock. According to this classification, the in-situ stress measurement methods are classified into 5 major types. **Table 2** presents this classification. For instance, among the methods that use drill cores, the tangent modulus method is an improved oriented core method to determine in-situ rock stresses where the cylindrical specimens prepared along different directions from thick core samples were uniaxially compressed twice to a given stress level. The

Corresponding author: Majid Nikkhah  
e-mail address: [m.nikkhah@shahroodut.ac.ir](mailto:m.nikkhah@shahroodut.ac.ir)

**Table 1:** Methods of determining in-situ stress in terms of their effect on the rock condition (Ljunggren et al., 2003)

Category	Method
Methods that disturb the in-situ rock conditions	hydraulic methods, (HTPF, hydraulic fracturing)
	borehole relief methods
	surface relief methods
Methods based on the observation of rock behaviour without any significant impact from the measuring method	statistics of measured data (database)
	core-discing
	borehole breakouts
	relief of large rock volumes (back analysis)
	acoustic methods (Kaiser effect)
	strain recovery methods
	geological observational methods
earthquake focal mechanisms	

stress value of the bending point in the first loading cycle of the stress-tangent modulus curve is considered as the normal component of the in-situ rock stress along the drilled direction of the specimen (Fuji et al., 2018).

The third classification is based on the changes that have occurred in the rock volume of the specimen or the relation between these changes and the pre-existing stress field. According to Table 3, in this classification, the in-situ stress measurement methods are divided into three major groups (Villaescusa et al., 2003).

According to the above tables, the acoustic emission method is regarded as one of the in-situ stress determination methods wherein the core drill is used. It is among the stress stressing-destressing methods and is based on observing the rock behaviour without having a major impact on the in-situ stress conditions.

### 1.2. Acoustic emission

Generally, it could be stated that often solids which are under stress, emit sound noises or seismic signals. Thus, the occurrence of deformation and fracture of rocks is associated with acoustic emission. This means that the emission of sound or ultrasonic waves is related to irreversible or somehow reversible structural changes. The acoustic emission event mechanism has been studied in various research works. When a rock sample is subjected to compressive loading, there are two sources for acoustic emission. These sources are the frictional movement on the pre-existing crack planes and abrupt advance of the crack tip, and sliding along the crack surfaces. In geological materials, the source of acoustic emission is not clearly specified, but it is related to the deformation process or fracture, which are associated with sudden strain energy release. In the geological materials which have a multi-crystal nature, the acoustic emission at the micro levels are due to dislocations, or at

**Table 2:** In-situ stress determination methods in terms of the involved rock volume (Ljunggren et al., 2003)

Category	Methods	Rock Volume (m <sup>3</sup> )
Methods performed in boreholes	Hydraulic fracturing	0.5-50
	Overcoring	10 <sup>-3</sup> – 10 <sup>-2</sup>
	HTPF	1-10
	Borehole breakouts	10 <sup>-2</sup> -10 <sup>2</sup>
Methods performed using drill cores	Strain recovery methods	10 <sup>-3</sup>
	Core-discing	10 <sup>-3</sup>
	Acoustic methods (Kaiser effect)	10 <sup>-3</sup>
Methods performed on rock surfaces	Jacking methods	0.5-2
	Surface relief methods	1-2
Analysis of large-scale geological structures	Earthquake focal mechanism	10 <sup>9</sup>
	Fault slip analysis	10 <sup>8</sup>
Others	Relief of large rock volumes (back analysis)	10 <sup>2</sup> -10 <sup>3</sup>

the macro levels due to twinning, may cause the grain boundary motion or initiation and propagation of fractures between and through the grains (Hardy Jr., 2003). Acoustic emission in the brittle rocks is often related to the propagation of microcracks, and in deformable rocks, it is due to the plastic flow mechanisms of dislocations. In Figure 1, the principles of acoustic emission method are presented. Acoustic emission is monitored by sound-seismic sensors. In laboratory environments, the piezoelectric type sensors are utilized. These sensors convert the elastic waves into electrical pulses. Then the pulses are directed to a preamplifier which contains a circuit for filtering of the signals. After preamplifier, the signals are transmitted to the recorder and the processor tool (Nikkhah, 2013).

Figure 2 presents the important parameters of the acoustic emission signal. The main AE signal parameters are defined as below (Ali et al., 2019):

AE hit is a signal that exceeds the threshold and causes data to be collected by the system.

Amplitude is the maximum voltage measured in waveform that is directly related to energy. The unit of amplitude is usually decibels (dB) or millivolts (mV).

Duration is the time interval between the first and last signal and the threshold intersection point. The unit of duration is generally microseconds ( $\mu$ sec).

Rise time is defined as a period of time between the first signal and threshold intersection point and the peak of AE signal. The unit of rise time is microseconds ( $\mu$ sec).

AE counts is the number of times the signal goes beyond the current threshold. The AE counts are representative of the AE activity.

**Table 3:** In-situ stress determination methods in terms of relation with the pre-existing stress field (Villaescusa et al., 2003)

Category	Method	Required access	Sensing method
Destressing techniques	Stiff inclusion	Borehole	Strain
	Soft inclusion	Borehole	Strain
	Hollow inclusion	Borehole	Strain
	Strain gauge rosettes	Borehole	Strain
	Hemispherical inclusion	Borehole	Strain
	Photoelastic inclusion	Borehole	Strain
	Deformeter	Borehole	Strain
	Doorstopper	Borehole & Rock Face	Strain
	Borehole slotter	Borehole	Strain
	Differential strain relaxation	Core	Strain
	Pin array undercoring	Rock Face	Displacement
	Tunnel undercoring	Tunnel, Shaft or Chamber	Displacement
Hole deeping	Borehole	Displacement	
Destressing-Stressing techniques	Flat Jack	Rock Face	Pressure & Displacement
	Circular Jack	Rock Face	Pressure & Displacement
	Acoustic Emission	Core	AE Count
Overstressing techniques	Jack fracturing	Borehole	Pressure
	Borehole Breakout	Borehole	Pressure & Displacement
	Core dinking	Borehole	Caliper
	Earthquake Focal Mech.	Borehole	Interpretation
	Geological features	Rock face, Core & Exposure	Interpretation

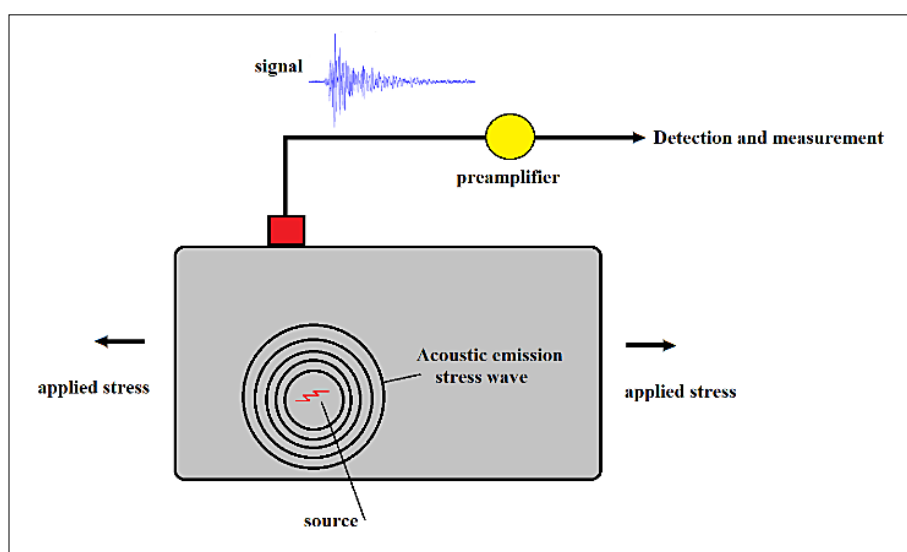
**Figure 1:** Acoustic emission principles (Nikkhah, 2013)

RMS is defined as the root mean squares of the AE hits amplitude. The RMS is used because of its physical importance. The unit of RMS is volts.

ASL is the average of the amplitude of AE signal. The unit of ASL is dB.

Energy is defined as the measured area under the rectified signal envelope, with units that usually depends on the AE data acquisition method.

Peak frequency is another widely used parameter in the analysis of acoustic emission signals. To obtain this parameter, one should convert the signal from time do-

main to frequency domain. The peak frequency is the frequency wherein the maximum intensity has occurred.

### 1.3. Kaiser effect mechanism and theory

The Kaiser effect was discovered by Joseph Kaiser, during his studies on wood, rock and metal samples in 1950 and is named after him (Kaiser, 1950). The Kaiser effect is the measurement of developed damage in the materials under the initial loading, which is observed during the consecutive uniaxial loadings and unloadings. In the simplest state, when the stress in the second

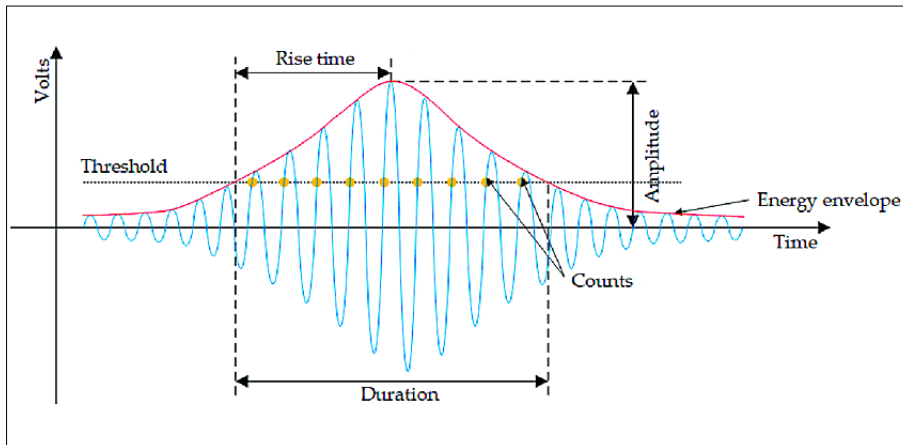

**Figure 2:** Acoustic emission signal parameters (Liang et al., 2020)

loading cycle exceeds the previous stress value, the sound emission and intensity increase, vigorously. In continuation, this issue would be investigated comprehensively. **Figure 3** shows an example of the Kaiser effect between the loading cycles AB and CBD. The diagram given in **Figure 3** is derived without re-adjusting the cumulative counting of emissions between the cycles. Recording of the data again is continued from the end of the previous cycle. When the stress level reaches the value of materials strength, the Kaiser effect begins to weaken (**Figure 3**, the CBD and EFG portions) and finally, when the stress level approaches the ultimate strength of rock, a higher Kaiser effect is not observed. As in some cases, (and perhaps in many cases), the Kaiser effect is not fully observed, therefore a ratio is defined, named the Felicity ratio, which is the Kaiser stress value divided by the previous maximum stress value. The full Kaiser effect occurs where we have  $FR \sim 100\%$ , or in other words, the actual Kaiser effect has a ratio equal to 100% (Nikkhah, 2013).

The first condition for estimating stress by the Kaiser effect is that the previous stresses should have produced damage in the rock. The other essential condition is that

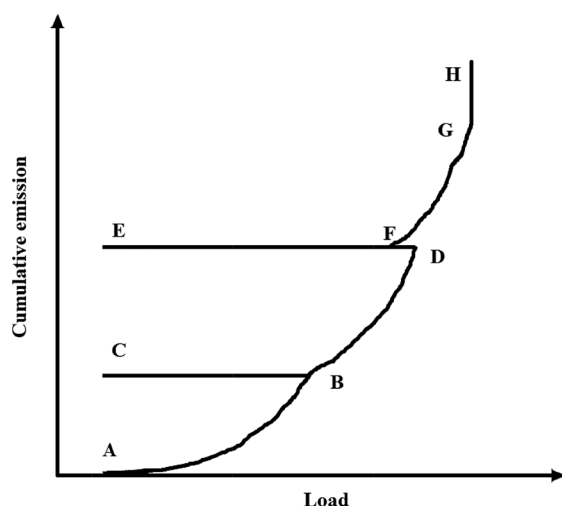

**Figure 3:** Cumulative event diagram of acoustic release versus load including three loading cycles (Lavrov, 2013)

loading in the acoustic emission experiments should have been applied in the direction of the previous principal stresses (Li, 1998).

To know whether the Kaiser effect is able to determine in-situ stress, we need to know the mechanism by which the Kaiser effect occurs. In this section, a number of research studies about the mechanism of the Kaiser effect are presented.

The rock deformation and failure is related to the growth and coalescence of cracks. Therefore, the concept of damage is more useful than the formalism of plasticity in describing the behaviour of brittle rocks (Holcomb, 1985). Rock remembers the maximum previous stress through the developed damage. The Kaiser effect method can detect the maximum previous stress only when the specimen is tested under conditions which exactly emulate the original conditions (Holcomb & Martin, 1985). Li and Nordlund suggested that AE is produced in abundance at the beginning of loading. This is due to the closure of open cracks. This is also considered by cracking from stress concentration due to the mismatch of the specimen. In their research, with an increase in the compressive stress, the AE count rate decreased gradually, and dropped to the low level of the background noise at the end. The AE count rate began to deviate from the background level and increased rapidly at a certain stress level. New damage starts to develop at this point (Li & Nordlund, 1993a).

Stuart et al. performed the uniaxial compression test on the sandstone specimens and recording the acoustic emission parameters, associated the abrupt increase in the acoustic parameters with the initiation of dilatant crack propagation. They studied the presence of the Kaiser effect in AE, where the AE depends on the difference between the major and minor principal stress. They suggested if the principal stress directions remaining fixed cause the stress difference to reduce then the AE cease, and renewed AE only occurs when the stress difference exceeds the previous maximum value for fixed values of the minor and intermediate principal stresses (Stuart et al., 1993).

Tang et al. developed a rock damage model to study the mechanism of the Kaiser effect. They quantitatively

proved the relationship between the number of AE counts and the statistical distribution of local rock strength. According to the damage theory, an expression for the Kaiser effect under uniaxial stress was extracted from the model by them. There was good agreement with the experimental results (Tang et al., 1997).

There are two main sources for AE when a rock specimen is under loading compressively. The frictional movement on the surfaces of pre-existing crack surfaces is the first one, and the second one is the fracture of intact material. The background AE due to the frictional movement might linearly increase with the applied load. The fracture of intact material commences only when the applied load reaches a certain level, and therefore AE activities start to increase rapidly (Li, 1998).

The state of damage caused by the previous loading on the rock is remembered through the Kaiser effect. No new damage is developed until the reloading stress exceeds the previous maximum stress. Assuming that the stress applied to the rock specimen is  $\sigma_{(i)}$ , then the elements are destroyed with strength less than  $\sigma_{(i)}$  accompanied by AE events. During the next loading process, no new elements are destroyed until the stress exceeds  $\sigma_{(i)}$  and actually no AE events occur. For the situation of cyclic loading of the  $i$ th time, the authors suggested the generalized equation of the accumulative number of destroyed elements as follows (Yuan & Li, 2008):

$$\frac{N_i}{N} = \begin{cases} 0, & \sigma \leq \sigma_{(i-1)} \\ \int_{\sigma_{(i-1)}}^{\sigma} \phi(t) dt, & \sigma > \sigma_{(i-1)} \end{cases} \quad (1)$$

Where:

- $t$  – loading level,  $t = 1, 2, 3, \dots, n$ ,
- $\sigma_{(i-1)}$  – the stress level at the  $(i-1)$ th loading,
- $N_i$  – the accumulative number of failure elements at the  $i$ th loading,
- $\phi_{(i)}$  – the failure probability of element.

The failure of elements accompanies the AE activity, therefore Eq. (1) is the real mechanism of the Kaiser effect, when the material under cyclic loading follows the same path (Yuan & Li, 2008).

## 2. Kaiser effect point estimation methods

### 2.1. Parametric methods

The first attempt for investigating the Kaiser effect in a special rock type (sandstone) was done by Goodman in 1963 (Goodman, 1963). One of the initial attempts for implementing the acoustic emission method for determining the in-situ stresses in rock was done by Kanagawa and Nasaka in 1967 in Japan. They proposed that the Kaiser effect levels obtained from the stress response of cumulative count of acoustic emissions could be used for calculating the in-situ stress (Kanagawa et al.,

1976). Next, Kurita and Fujii in 1979 studied the effects of water saturation and time delay between the loading cycles on the Kaiser effect. Their studies reached a desirable result and revealed that the stress memory of rocks is like the humans memory and diminishes with the passage of time (Kurita & Fujii, 1979). Michihiro et al. in 1989 investigated the Kaiser effect on rock types such as tuff, mudstone, sandstone, schist and marble. The experiments were performed in the two saturated and unsaturated states (Michihiro et al., 1985). Hughson and Crawford investigated with an extensive laboratory that resulted in the development of Kaiser effect gauging as a practical system to determine the in-situ stress by conducting Acoustic Emission tests on extracted core (Hughson & Crawford, 1986). Montoto and Hardy performed a general and modified review of the performed studies on the Kaiser effect in the geological materials. They investigated the specimen environment, test procedure, multiple stress states and other effects. They introduced the Kaiser effect as a simple and economic method for the measurement of in-situ stress (Montoto & Hardy, 1991).

In 1993, Li and Nordlund performed an experimental study on the Kaiser effect in rocks. They used the uniaxial test and tested 61 granite and other types of specimens, and using the count parameter estimated the Kaiser effect point (Li & Nordlund, 1993b). Stuart et al. investigated the effects of stress memory on the anisotropic rocks under uniaxial stress loading. In their studies, the cubical specimens were loaded stagewise along a number of perpendicular directions and then were stagewise reloaded again. At the second stage, by uniaxial loading at each direction, a value for the Kaiser effect level was observed which was equal to the applied stress along the preloading direction. They stated that the Kaiser effect in acoustic emission depends on the difference between the maximum and minimum principle stresses. Their results presented a strategy for the measurement of stresses based on the measurement of borehole core and the borehole itself. They applied the hit rate parameter in their analyses (Stuart et al., 1993).

Pestman and Van Muster in 1996 proposed that after performing the acoustic emission tests on the triaxially loaded specimens under different loading values, it is possible to determine the principle stresses using the peak point on the damaged plane, but knowledge of the direction of principle stresses is essential in this method (Pestman & Van Munster, 1996). Tuncay and Ulusay investigated the relationship between the Kaiser effect and the previous applied stress on the sample. They used cumulative count. In their study, rate increment (RI(t)) is determined for all points on a “time–cumulative AE count” graph. The peak value, which is well recognized according to the previous peaks on a “Time–RI(t)” graph, corresponds to the point where the AE activity begins to increase significantly. This point is considered as the KE level and its value is equal to the stress which

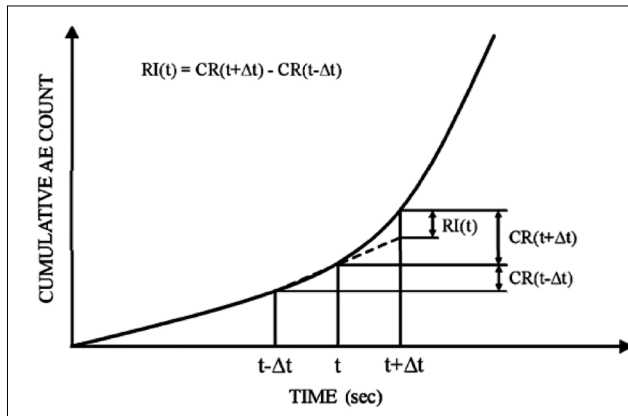

**Figure 4:** Determination of increment ( $RI(t)$ ) from “cumulative AE count-time graph (Tuncay & Obara, 2012)

acts on the specimen at that time (see **Figure 4**) (Tuncay & Obara, 2012).

Blanksma used the tangential method to determine the point of the Kaiser effect. In this method, after plotting the cumulative AE hit with respect to the stress, the inflexion point is considered as the Kaiser effect point (see **Figure 5**). Bilinear regression is used for the accurate determination of the value of  $\sigma_m$ . The intersection point of them on the stress axis represents the Kaiser effect stress (Lavrov, 2003).

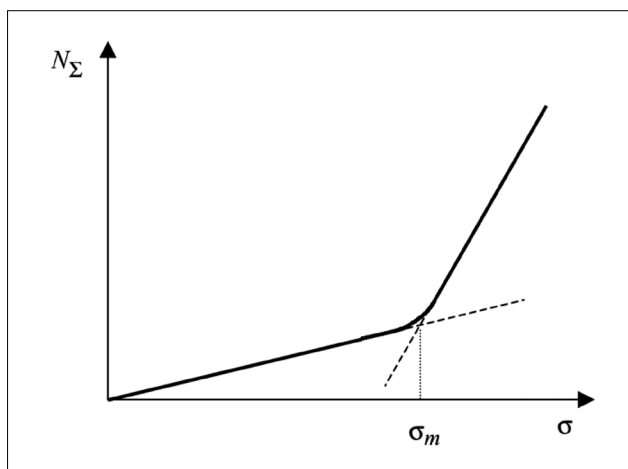

**Figure 5:** Influence in the cumulative AE hits ( $\Sigma N$ ) versus stress ( $\sigma$ ) graph indicates the previous maximum stress state (Lavrov, 2003)

Nikkhah et al. determined the point of the Kaiser effect by using pattern recognition methods and acoustic parameters. The results showed that pattern recognition methods and the proposed method can be used to determine the Kaiser effect point with an acceptable level of accuracy. The proposed method uses the main parameters of acoustic emission including duration, energy, count, and rise time, but it should be noted that the mechanism of wave emission source is excluded (Nikkhah et al., 2011). Hsieh et al. used the parameter of the number of events for parametric analysis of the results

obtained from acoustic emission test and determining the Kaiser effect point (Hsieh et al., 2015). Yu et al. used the count parameter to determine the Kaiser effect (Yu et al., 2015). As can be seen in **Figure 6**, Zhao et al. directly interpreted the relationship between an acoustic emission parameter and time. In this method, a significant increase of acoustic emission after a certain time point is considered as the Kaiser effect point (Zhao et al., 2018).

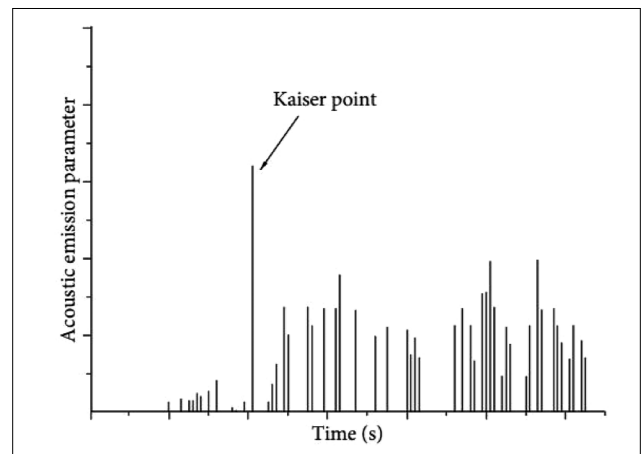

**Figure 6:** Determination of Kaiser effect point using acoustic emission parameters (Zhao et al., 2018)

Srinivasan et al. used the count and energy parameters in cumulative form with respect to the applied stress to determine the Kaiser effect point. In 2021, Kharghani et al. used the energy parameters in cumulative form to determine the Kaiser effect point. The cumulative energy with respect to time was plotted and where a significant increase in the energy parameter was considered as the Kaiser effect location.

In this section, reference is made to the five most important parametric methods for estimating the Kaiser effect point of rocks.

The first method: in this method, the Kaiser effect method is determined by fitting two straight lines with the application of bilinear regression. In this method, two global tangent lines are fitted over the upper and lower parts of the Kaiser effect point. After calculating the errors corresponding to the fitted lines, the point with minimum error would be the Kaiser effect point. The stages of this method are as follows (Nikkhah, 2013):

1. Per each point ‘ $p$ ’ on curve  $f(\cdot)$  (same cumulative curve of acoustic emission parameter), the following operations are performed:

i: Over all the points of the curve which are located at the left side of point ‘ $p$ ’ ( $f(x < p)$ ), a line is fitted and its corresponding error is designated with  $e_1$

ii: Over all the points of the curve which are located at the right side of point ‘ $p$ ’ ( $f(p < x)$ ), a line is fitted and its corresponding error is designated with  $e_2$

iii: The total error of fitting is equal to  $e = e_1 + e_2$

2. The point with minimum fitting error  $e$  is selected as the Kaiser effect point.

The second method: similar to the first one, two lines are drawn at the left and right sides of the Kaiser effect point, but here the fitting type is local, while in the first method the fitting type is global. The stages of this method are as follows (Nikkhah, 2013):

1. It is assumed that  $k = \max(10, \text{length}(f(\cdot)))$

2. Per each point 'p' on curve  $f(\cdot)$ , the following operations are done:

i: over the 'k' points on the left side of point 'p' ( $f(p-k < x < p)$ ), a line is fitted and its corresponding error is designated with  $e_1$

ii: over the 'k' points on the right side of point 'p' ( $f(p < x < p+k)$ ), a line is fitted and its corresponding error is designated with  $e_2$

iii: the total error of fitting is equal to  $e = e_1 + e_2$

3. The point with minimum fitting error  $e$  is selected as the Kaiser effect point.

The third method: according to this method, first the difference between the considered squared cumulative parameter and cumulative parameter is calculated, and then the first method is used for determining the Kaiser effect point from the obtained function. The stages of this method are as follows (Nikkhah, 2013):

1. Curve  $g(\cdot)$  is calculated from curve  $f(\cdot)$ , using Equation (2):

$$g(x) = f^2(x) - f(x) \quad (2)$$

Where:

$f_{(x)}$  – the cumulative curve of acoustic emission parameter.

2. Per each point 'p' on curve  $g(\cdot)$  the following operations are done:

i: over all the points of the curve which are located at the left side of point 'p' ( $g(x < p)$ ), a line is fitted and its corresponding error is designated with  $e_1$

ii: over all the points of the curve which are located at the right side of point 'p' ( $g(p < x)$ ), a line is fitted and its corresponding error is designated with  $e_2$

iii: the total error of fitting is equal to  $e = e_1 + e_2$

3. The point with minimum fitting error  $e$  is selected as the Kaiser effect point.

The fourth method: in this method, which is the method proposed by Villaescusa et al., use is made of the changes in the normalized slope of the cumulative curve of the acoustic emission parameters. Here the slope threshold is taken equal to 20 degrees and 10 points are considered instead of 5 to expand the investigated interval in the corresponding equation. The stages of this method are as follows (Nikkhah, 2013):

1. It is assumed that  $\delta = 10$  (interval includes 10 points) and the threshold is taken as  $th = 0.2$

2. Per each point 'p' on curve  $f(\cdot)$ , the local slope of point 'p' is calculated using Equation (3) (Nikkhah, 2013):

$$m = \frac{f(p + \delta) - f(p - \delta)}{\sigma_{p+\delta} - \sigma_{p-\delta}} \quad (3)$$

Where:

$\sigma$  – the number of intervals,

$p$  – a point on the curve,

$\sigma_{p+\delta}$  – the stress corresponding to point  $p + \delta$ ,

$\sigma_{p-\delta}$  – the stress corresponding to point  $p - \delta$ .

3. After calculation of the curve slope 'm' for all the points, the 'm' values are normalized by Equation (4) to obtain the 'mn' curve (Nikkhah, 2013):

$$mn = \frac{m - \min(m)}{\max(m) - \min(m)} \quad (4)$$

Where:

$m$  – the slope of point  $p$  on the curve.

4. The first point on the 'mn' curve where its value exceeds the threshold value is identified as the Kaiser effect point.

The fifth method: this method is proposed by Nikkhah et al. According to this method, the Kaiser effect point is determined by calculating the slope of intersection on the cumulative curve of the considered parameter, and by moving from the left to right on the curve. The point with the greater slope is considered as the Kaiser effect point. The following stages depict the way of implementing this method:

1. the slope of point 'x' with respect to point 'p' of curve  $f(\cdot)$  is calculated using Equation (5) (Nikkhah, 2013):

$$m = \frac{f(x) - f(p)}{x - p} \quad (5)$$

Where:

$x, p$  – points on the curve,

$f(x), f(p)$  – the cumulative curve of acoustic emission parameter.

2. Per each point 'p' of curve  $f(\cdot)$ , the following operations are done:

i. The sum of all the slopes corresponding to the points on the curve which are located at the right side of point 'p' ( $f(p < x)$ ) is calculated with respect to point 'p' and designated by 'm'.

ii. The point with maximum 'm' value is selected as the Kaiser effect point (Nikkhah, 2013).

## 2.2. Signal processing method

The most important signal processing methods used for the analysis of acoustic emission signals and consequently estimating the Kaiser effect point are the frequency analysis methods. After the introduction of the Fast Fourier Transform in the 1960s, the frequency analysis methods came under the focus of attention and were implemented in experiments related to acoustic emission. These methods include filtering procedures, noise removal and other complicated procedures. These meth-

ods investigate the correlation between the frequency content of a signal and the parameters corresponding to the source of a signal to classify the events in terms of the fracture mechanism. FFT converts a time series to a frequency spectrum. The Fourier transform of a signal  $x(n)$  is calculated by Equation (6) (Soundararajan et al., 2006):

$$x(n) = \frac{1}{2\pi} \int_{-\infty}^{\infty} X(\omega) e^{j\omega n} d\omega \quad (6)$$

Where:

$$X(\omega) = \sum_{n=-\infty}^{\infty} x(n) e^{-j\omega n} \quad (7)$$

Where:

- $x(n)$  – the input signal,
- $X(\omega)$  – a set of weighted coefficient.

Equation (6) indicates the decomposition of the input signal  $x(n)$  into a set of weighted coefficients  $X(\omega)$  per each harmonic from  $e^{j\omega n}$ . Equation (7) is independent of time and exhibits compositions of the frequencies corresponding to the static signal  $x(n)$  (Soundararajan et al., 2006).

The Fourier Transform gives us information about the signal frequency and tell us the frequency number in each signal, but it does not tell us at what time this frequency exists. Therefore, the Fourier Transform is not a good technique for non-static signals. After the introduction of the Fourier Transform method and in order to overcome its deficiencies, the short term Fourier Transform and wavelet transform methods were presented in later years which greatly helped with the analysis of different signals, including the acoustic emission signals. In this method, a window function “ $\gamma$ ” is selected where its width should be equal to a segment of the signal that is static. Calculation of STFT is done using the following equation (Boashash, 2003):

$$F_x^\gamma(t, f) = \int_{-\infty}^{\infty} x(t') \gamma(t'-t) e^{-j2\pi ft'} dt' \quad (8)$$

Where:

- $\gamma$  – the window function,
- $t'$  – the duration of a window function.

The idea behind presenting and developing the wavelet analysis was to describe the non-static signals in a 2D space of time scale. The wavelet transform provides this possibility that where there is a need for lower frequency information with high accuracy, one could use longer time intervals. Also, where there is a need for high frequency information, one could use shorter time intervals. The wavelet transform has different types but the most important types are the continuous wavelet transform, discrete wavelet transform and wavelet packet transform (WPT).

CWT is defined as (9) (Wang et al., 2016):

$$W(a, b) = \frac{1}{\sqrt{a}} \int f(t) \psi^* \left( \frac{t-b}{a} \right) dt \quad (9)$$

Where:

- $a$  – scaling parameter,
- $b$  – translation parameter,
- $\psi^*$  – the complex conjugate of  $\psi$  (wavelet basis function).

The discrete wavelet transform is used for decomposing a signal into a set of coefficients. The discrete wavelet transform could exhibit the non-static characteristics of a signal. For a mother wavelet and decomposition level  $j$ , the discrete wavelet transform for signal  $f(t)$  is equal to (Wang et al., 2018):

$$W_f(j, k) = \int_{-\infty}^{+\infty} f(t) \psi_{j,k}^*(t) dt \quad (10)$$

$$\psi_{j,k}(t) = a_0^{-j/2} \psi(a_0^{-j} t - b_0 k) \quad (11)$$

Where:

- $a_0, b_0$  – constants,
- $k$  – the time translation factor,
- $\psi_{(j,k)}^*$  – the complex conjugate,
- $Wf_{(j,k)}$  – the coefficient of discrete wavelet at level  $j$ .

The aim of wavelet transform is decomposition of the main signal into a series of approximations (A) and details (B) which are distributed over different frequency bands, which retain the time domain and frequency domain properties. The decomposition tree is shown in Figure 7.

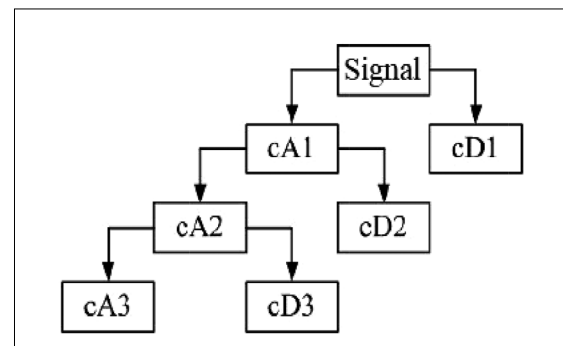

Figure 7: Wavelet decomposition tree showing approximations and details of signal for three levels (Soundararajan et al., 2006)

The wavelet packet transform (WPT) is similar to discrete wavelet transform (DWT). The only difference lies in the structure of the algorithm used for wavelet transform application. WPT continuously applies the wavelet transform on the scale coefficients and wavelet coefficients (high-pass filter and low-pass filter coefficients, respectively).

Gang Fang et al. denoised the acoustic emission signals using the packet wavelet transform method and then determined the Kaiser effect point using the energy parameter and the frequency characteristics of the acoustic emission signal (Geng-feng, 2006). Kyriazis et al. (2006) demonstrated that by using the wavelet trans-



form, it is possible to perform spatial positioning of the signal energy and assess the difference between the specimens under pressure or without pressure and also the deformation rate in specimens. They stated that the selection of an appropriate mother wavelet is of great importance. Its selection not only from the types of wavelet groups but also selection of a wavelet from a specific group could affect the analysis results. They used the wavelet Daubechies 3 in their study (Kyriazis et al., 2006). Zhao et al. suggested that wavelet transform is an efficient technique to eliminate signal noise and process acoustic emission signals and determine the Kaiser effect point. They first used the Fourier Transform method in their analysis and determined the Kaiser effect point by drawing the count diagram against time (Zhao et al., 2006). In 2008, Zhao et al. used the wavelet analysis techniques to remove the noise in the acoustic emission test for investigating the Kaiser effect. They applied Daubechies 4 wavelet to remove the noises and the oscillogram showed that the noises were well removed. They determined the point of the Kaiser effect by analysing the fractal properties of the acoustic emission energy signal (Zhao et al., 2008). Using discrete Fourier transform, Hou et al. classified peak frequency values obtained by transmitting acoustic emission signals from the time domain to the frequency domain for different samples. Then the mechanism of the Kaiser effect was investigated (Hou et al., 2021). In 2022, Dinmohammadpour et al. used wavelet transform to process acoustic emission signals for determining the Kaiser effect point (Dinmohammadpour et al., 2022).

### 2.3. Comparison of parametric and signal processing methods

One of the advantages of the parametric method is its high speed in recording and storage of the data which results in rapid imaging, which consequently makes it an economic method. In contrast, in the spatial signal processing method where a full signal recorded by different sensors is stored, the recording system is turned off for a short time while the data are being stored (which is called delay or dead time). This issue could result in loss of data. Only by storing a number of data, one could significantly reduce the time delay. On the other hand, reducing a full signal into a number of parameters could create significant limitations and sometimes may lead to confusion.

In practice, after reducing a signal into a number of limited parameters, differentiation between an acoustic emission signal and noise (for example the noise produced by electronic pulses) would be a difficult task. This problem is more visible when resonant sensors are used since such sensors could make the signal difference become further hidden. Extraction of simple parameters which express the signal characteristics is harder when using the wideband sensors. One of the most important issues is the dependence of acoustic emission signals on

the material and geometry of the samples. Different types of waves like compression, shear or surface waves, also existing reflections in the signal shape cause further complexity. One of the most important advantages of signal processing method is its capability in differentiating between the main signal and noise based on the wave shape. As the wave shape after measurement is accessible and unlike the parametric method it is not cleared. Furthermore, there is possibility of implementing different signal analysis methods and related software. In case of using signal oriented methods, the validity of data interpretation is highly increased. The problem associated with the signal oriented method is that often a lower number of events could be recorded (Grosse & Ohtsu, 2008). Generally, it could be stated that application of the signal-oriented method, due to its important advantages, is more desirable. Albeit, selecting this method depends on the available equipment and financial limitations.

### 3. Comparing the Kaiser effect method to other in-situ measurement methods

Comparing the acoustic emission method based on the Kaiser effect phenomenon with other common methods for measurement of in-situ stress such as over-coring and hydraulic fracturing, has greatly helped with confirming this method as a proper method to determine in-situ stress. In this section, we will refer to some performed studies with the aim of comparing the Kaiser effect method with other ones.

Kanagawa and Hayashi compared the Kaiser method to the over-coring method. They tested 111 tuff specimens. The results of the Kaiser effect method were greater than those of the over-coring method. They stated that a problem associated with the calculation of stress by the Kaiser method in the laboratory is the removal of signals due to stress concentration at the corners of the specimens during experiment (Kanagawa et al., 1976). Jingen et al. performed a comparison between the Kaiser effect method and the hydraulic fracturing method. The corresponding results are given in Table 4 (Jingen et al., 1995). As is observed, there is a good agreement between the results. The depth was 4340 m.

A comparison between the Kaiser effect method and hydraulic fracturing and over-coring methods was performed by Seto et al. The results agreed in different

**Table 4:** Comparison between the stresses obtained from the Kaiser effect and the hydraulic fracturing methods for three different specimens (Jingen et al., 1995)

Method	KE Method (MPa)		Hydraulic fracturing Method (MPa)	
	$\sigma_{h \max}$	$\sigma_{h \min}$	$\sigma_{h \max}$	$\sigma_{h \min}$
Sample 1	116.3	85.1	114.1	84.6
Sample 2	155.2	104	162.5	120.9
Sample 3	95.5	76.2	93.4	76.2

methods. The specimens tested by them included sandstone and shale (Seto et al., 1998). Seto et al. performed another study in 1999. They used specimens made of granite and sandstone to perform the acoustic emission test. They compared the results of determined in-situ stresses based on the Kaiser effect with those obtained using the over-coring and hydraulic fracturing methods. The agreement of results of different methods was acceptable (Seto et al., 1999). Seto and Villaescusa made the comparison along three directions namely; normal to bedding, along the strike of bedding and down dip of bedding. The specimen used in the test was of granite type. The results of these three methods were close with each other (Seto & Villaescusa, 1999). Table 5 shows the results of these three methods. The depth was 245 m.

**Table 5:** Stresses obtained from the Kaiser effect and over-coring methods at different directions (Seto & Villaescusa, 1999)

Orientation of testing	AE (MPa)	Overcoring (MPa)
Normal to bedding	8.4	6.5
Along the strike of bedding	7.3	8.2
Down dip of bedding	5.6	5.6

The research performed by Wang et al. showed that the results obtained from the acoustic emission proposed by them has a good agreement with the over-coring method. They also suggested that at greater depths both the acoustic emission and hydraulic fracturing methods be used simultaneously to increase the accuracy of results (Wang et al., 2000). Kent et al. made a comparison between the acoustic emission method based on the Kaiser effect and over-coring method. As is seen in Figure 8, correlation coefficient between the results of these two methods are close to 1. They proposed that the Kaiser effect method is an appropriate alternative for deter-

mining the in-situ stress with respect to other time consuming and costly previous methods (Kent et al., 2002).

The acoustic emission method and the DRA method were compared by Seto et al. Delay time was 21 days and specimens were from granite and sandstone. The results of the acoustic emission method have a good accuracy in determining the in-situ stress (Seto et al., 2002). The results obtained by Villaescusa et al. showed that the results of their proposed method (that was based on the Kaiser effect), were very close to the over-coring method results, but with the difference that their proposed method was less costly and did not require specific accessibility (Villaescusa et al., 2002).

Li and Zhang made a comparison between the Kaiser effect and the hydraulic fracturing methods. Their specimens were made of gabrodiorite type which was extracted from depths in the range of 270-294m. They stated that the two methods show a good agreement with each other (Li & Zhang, 2003). Lehtonen used the Kaiser effect method for determining the in-situ stress and compared the results with the over-coring method. The used specimens were made of granite and gneiss. He suggested that there is a good correlation between the results of Kaiser effect method and traditional methods (Lehtonen & Särkkä, 2006). Once again in 2006, Villaescusa et al. compared the results obtained from their proposed method with those obtained by the over-coring method at dif-

**Table 6:** Comparison between the stresses obtained by Kaiser effect and hydraulic fracturing methods (Nikkhah, 2013)

Stress	Kaiser Effect Method	Hydraulic Fracturing Method
$\sigma_H$	3.73	3.95
$\sigma_V$	1.9	2.35
$\sigma_h$	2.5	2.3

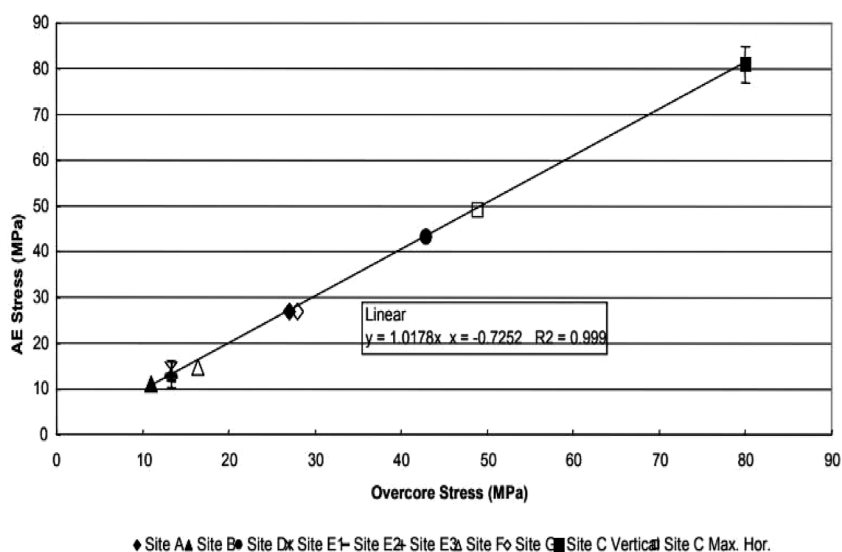

**Figure 8:** Comparison of stress determination from overcore stress measurement sites and AE testing for the Kaiser effect (Kent et al., 2002)

**Table 7:** Comparison between the stresses obtained from the Kaiser effect, over-coring and hydraulic fracturing methods (Bai et al., 2018)

Stress	KE Method	Overcoring Method	Hydraulic Fracturing Method
maximum principal stress (MPa)	24.4	24.3	25.7
intermediate principal stress (MPa)	17.1	17.3	17.8
minimum principal stress (MPa)	6.1	6.4	–

ferent depths of mines in Australia, which showed a good agreement between them (Villaescusa et al., 2006). Nikkah stated that the estimated stresses using the Kaiser effect method had a relatively good agreement with those obtained by the hydraulic fracturing method. The obtained results are given in Table 6 (Nikkah, 2013).

Bai et al. determined the in-situ stress using the acoustic emission method. In comparison to the hydraulic fracturing and over-coring methods, the results were close to each other. They revealed the reliability of the Kaiser effect method in determining the in-situ stress. The depth was 476 m. The strike is NNW 330–340°, the dip direction is WSW 240–250°. The results obtained from calculation of the maximum and minimum principal stresses are given in Table 7 (Bai et al., 2018). Yang et al. compared KE method results with hydraulic fracturing results. They suggested that relative errors were in an acceptable range (Yang et al., 2021).

## 4. Influence of different factors

### 4.1. Experiment method and confining pressure

Holcomb stated that as the confining pressure increases, the load required for better observation of the Kaiser effect increases (Holcomb, 1983). Tuncay and Obara concluded that confining pressure has a significant effect on the Kaiser effect level (Tuncay & Obara, 2012). Nikkah evaluated the impact of confining stress on the Kaiser effect using the distinct element method. The results of his study showed that the amount of stress by the KE could be underestimated, so that increasing the enclosing pressure leads to increasing the difference between the stress obtained by the Kaiser effect method and the actual stress in the rock (Nikkah, 2017). Chen and Irfan investigated the Kaiser effect on marble specimens under cyclic uniaxial compressive, as well as cyclic uniaxial tensile conditions. They used marble specimens. The experimental results confirmed the presence of the Kaiser effect under both compressive and tensile loading conditions (Chen & Irfan, 2018). Belyukov studied the Kaiser effect during modelling of rock loading conditions. It was found that in the second loading cycle, the recovery of the initial values of axial component  $\sigma_{axial}$  of the specimen stress field, unloaded after the first cycle, stimulates acoustic emission. This regularity is true for the case when there is no increase in confining pressure  $\sigma_{conf}$  on the specimen between the cycles. In the

conditions with an increase in confining pressure  $\sigma_{conf}$  between the first and second cycles, the Kaiser effect is found at higher values of the  $\sigma_{axial}$  component than the initial ones (Belyukov, 2021).

### 4.2. Direction and magnitude of loading

Michihiro et al. investigated the impact of direction of principal stress on the Kaiser effect. Based on the results, the principal stress in one direction does not have an impact on the Kaiser effect in another direction (Michihiro et al., 1985). Lavrov et al. conducted tests in which specimens were loaded in two cycles with or without rotations between successive cycles. The rotation angle varied between 0° and 90°. The Kaiser effect became gradually less pronounced with an increase in the rotation angle, but remained detectable for angles <10°. The Kaiser effect was not pronounced with rotation by more than 10°. These experimental results were confirmed by numerical simulations using the displacement discontinuity method (Lavrov et al., 2002). Fuchsschwanz et al. carried out some experiments on granite specimens to study the influence of an axis rotation on the acoustic emissions and rock mass properties. For this purpose, they compared the acoustic emissions of specimens with and without a perpendicular preload. They found that neither the rock strength nor the acoustic emissions are influenced by a preloading orthogonal to the reloading direction (Fuchsschwanz et al., 2005). Vervoort and Govaerts suggested that one of the more important limitations of using the AE method to determine in-situ stresses is that the direction of in-situ stresses must be known within a 10° accuracy, otherwise reloading does not reproduce a Kaiser effect (Vervoort & Govaerts, 2006). Chen et al. used the Brazilian test on granite specimens under cyclic loading. Based on the results, if the pre-existing stress is smaller than the crack damage stress, the Kaiser effect is obvious, and if the pre-existing stress is greater than the crack damage stress, the Kaiser effect is clear (Chen et al., 2018).

### 4.3. Delay time and Retention time

Goodman observed the Kaiser effect for quartz diorite and sandstone within several hours (Goodman, 1963). Yoshikawa and Mogi found out that as the time delay increase, the Kaiser effect stress is underestimated (Yoshikawa & Mogi, 1978). Kurita and Fujii suggested the observation of the Kaiser effect is possible after a period of one month (Kurita & Fujii, 1979). Boyce showed

that the Kaiser effect is detectable accurately after 3 days (Boyce, 1981). Michihiro et al. stated that as the time between coring and testing increases, the accuracy of the stress estimation decreases (Michihiro et al., 1985). Momayez and Hasani suggested that the Kaiser effect is detectable after a period of two weeks (Momayez & Hassuni, 1992). Li and Nordlund studied the effects of the delay time between subsequent loading cycles and also the retention time on the Kaiser effect in tested granite specimens (Li & Nordlund, 1993b). Seto et al. studied the effect of delay time on using the Kaiser effect method. They found out in-situ stress estimation based on Kaiser effect, before a period of seven years, did not have a significant impact on the previous stress determination (Seto et al., 1999). Seto et al. applied the AE and DRA methods to determine the vertical stresses around a drift in sedimentary rock. They concluded that testing should be carried out within a delay time of up to 21 days to have successful tests (Seto et al., 2002). Yan et al. found that in-situ stress should be determined when the delay time was 40-120 days. The specimens had been composed of limestone (Jin et al., 2009). Nikkhah suggested the retention time and induction of stress in the samples are directly related to the delay time of the Kaiser effect so that the longer the stress induction and retention time on the sample, the longer the Kaiser effect delay time increases (Nikkhah, 2013). Jian-Hong et al. suggested that the delay time has minor impacts on the Kaiser effect (Jian-Hong et al., 2017). Fu et al. indicated the indirect effect of time delay on the KE of sandstone in the uniaxial compression test (Fu et al., 2021).

#### 4.4. Mechanical and physical properties

Yoshikawa and Mogi concluded that water and temperature have no influence on the stress history of the AE (Yoshikawa & Mogi, 1978). Kurita and Fujii suggested that the water content has a significant impact on the Kaiser effect. They showed that when a granite core was soaked in a water bath for one day, considerable AE was obtained, in the elastic region, at stresses much lower than the previous maximum stress (Kurita & Fujii, 1979). Lehtonen et al. studied the geological factors influencing the Kaiser effect testing results (Lehtonen et al., 2012). Bahrani et al. investigated the effect of some parameters such as stress path and heterogeneity on the Kaiser effect in brittle rocks (Bahrani et al., 2019). Meng et al. suggested the harder the rock, the sooner the Kaiser effect point is observed (Meng et al., 2019). Srinivasan et al. concluded rock heterogeneity has an influence on the Kaiser effect (Srinivasan et al., 2020). Ban et al. found that the material property (Poisson's ratio) and crack angle were the controlling factors of the Kaiser effect (KE) under tensile stress (Ban et al., 2020).

#### 4.5. Anisotropy angle

Tuncay and Obara found that the anisotropy in the granite, mainly related to the microcracks, have a sig-

nificant influence on the KE level. They showed microcrack opening and propagating, etc. which occurs during extraction and preparation of a test specimen, may result in the determination of another stress level rather than the in-situ stress determined by using the Kaiser effect method (Tuncay & Obara, 2012). Kharghani et al. investigated the effect of anisotropic angle on the Kaiser effect. They stated that in the uniaxial compression experiment, the angle of anisotropy had little effect on the Kaiser effect. However, in the Brazilian experiment, the Kaiser effect is sharper at a zero-degree angle. The criterion used in their research was the Felicity ratio (Kharghani et al., 2021).

#### 4.6. Loading rate

Meng et al. studied on the influence of loading rate on the Kaiser effect. As the loading rate increases, the Felicity ratio increases rapidly (Meng et al., 2019). Zhang et al. studied the effect of loading rates on in-situ stress determination accuracy using the Kaiser effect in different rocks. They showed that the higher the loading rate, the greater the Kaiser effect stress, for sandstone and mudstone. For brittle rocks such as limestone, the impact of loading rates on the Kaiser effect is negligible (Zhang et al., 2021).

### 5. Conclusion

Reviewing the performed research during the past decades on the Kaiser effect method, the following results were obtained.

A comparison between different methods of in-situ stress determination showed that the results obtained from the Kaiser effect method are very close to the results of conventional in-situ stress measurement methods. This suggests that the Kaiser effect may be a viable alternative to conventional methods.

Using the Kaiser effect method requires sufficient and accurate knowledge of the mechanism of its occurrence. The theories presented will be useful in this regard.

Most of the methods used for determining the Kaiser effect point include the parametric methods, but in case that the parametric methods lack enough precision, the best option for determining the Kaiser effect point is the use of the signal processing methods. These methods are based on mathematical transformations like the wavelet transform.

The effective parameters on determining the Kaiser effect point include: test procedure, confining pressure, the physical and mechanical characteristics of rock, delay time and load retaining time, anisotropy angle and loading rate.

Although there is no consensus on the use of the Kaiser effect method to determine the in-situ stress of rock masses, many researchers have demonstrated its potential and believe that it is possible to measure in-situ

stress using this method. However, because of this controversy, this method should continue to be used with caution, even in the very early stages of research. Engineering projects should be designed based on proven methods for determining in-situ stress.

## 6. References

- Bahrani, N., Valley, B., and Kaiser, P. (2019): Influence of stress path on stress memory and stress fracturing in brittle rocks. *Canadian Geotechnical Journal*, 56, 6, 852-867. doi: 10.1139/cgj-2018-0291
- Bai, X., Zhang, D., Wang, H., Li, S., and Rao, Z. (2018): A novel in situ stress measurement method based on acoustic emission Kaiser effect: a theoretical and experimental study. *Royal Society open science*, 5, 10. doi:10.1098/rsos.181263
- Ban, Y., Fu, X., Xie, Q., and Duan, J. (2020): Time-sensitivity mechanism of rock stress memory properties under tensile stress. *Journal of Rock Mechanics and Geotechnical Engineering*, 12, 3, 528-540. doi.org/10.1016/j.jrmge.2019.12.012
- Belyukov, N. (2021): Studying the Kaiser Effect During Modeling of Rock Loading Conditions Using the NX-borehole Jack. *Journal of Physics, Conference Series*, 1945, 1. doi:10.1088/1742-6596/1945/1/012023
- Boashash, B. (2003): Time frequency analysis: A comprehensive reference. Elsevier. doi:10.1016/B978-0-08-044335-5.X5020-7
- Boyce, G. (1991): A study of the acoustic emission response of various rock types. Master of Science Thesis. Drexel University. Philadelphia. United states of America. 170 p.
- Chen, Y., and Irfan, M. (2018): Experimental study of Kaiser effect under cyclic compression and tension tests. *Geomechanics and engineering*, 14, 2, 203-209. doi:10.12989/gae.2018.14.2.203
- Chen, Y., Irfan, M., and Song, C. (2018): Verification of the Kaiser effect in rocks under tensile stress: experiment using the Brazilian test. *International Journal of Geomechanics*, 18, 7. doi:10.1061/(ASCE)GM.1943-5622.0001181
- Dinmohammadpour, M., Nikkiah, M., Goshtasbi, K., and Ahangari, K. (2022): Application of Wavelet Transform in Evaluating the Kaiser Effect of Rocks in Acoustic Emission Test. *Measurement*, 192, 110887. doi:10.1016/j.measurement.2022.110887
- Fu, X., Ban, Y., Xie, Q., Abdullah, R., and Duan, J. (2021): Time Delay Mechanism of the Kaiser Effect in Sandstone Under Uniaxial Compressive Stress Conditions. *Rock Mechanics and Rock Engineering*, 54, 3, 1091-1108. doi: 10.1007/s00603-020-02310-0
- Fuchsschwanz, M., Labiouse, V., and Mathier, J. (2005): Influence of a 90-rotation of the loading axis on acoustic emission behavior of parallelepiped specimens of granite. *Proceedings of the International Symposium of the International Society for Rock Mechanics-EUROCK 2005*. Brno, Czech Republic, 141-146.
- Fujii, Y., Makasi, M., Kodama, J., Fukuda, D., Goto, K., Kumakura, S., Kanaoka, M., and Dassanayake, A. (2018): Tangent modulus method—An original method to measure in-situ rock stress. *Tunnelling and Underground Space Technology*, 82, 148-155. doi.org/10.1016/j.tust.2018.08.005
- Geng-feng, W. (2006): In-situ geostress test by rock acoustic emission based on wavelet packet analysis. *Geotechnical Engineering Technique*, 20, 4, 166-169.
- Goodman, R. (1963): Subaudible noise during compression of rocks. *Geological Society of America Bulletin*, 74, 4, 487-490. doi:10.1130/0016-7606(1963)74[487:SNDCOR]2.0.CO;2
- Grosse, C., and Ohtsu, M. (2008): *Acoustic emission testing*. Springer, Heidelberg. doi:10.1007/978-3-540-69972-9
- Hardy, H.R. (2003): *Acoustic Emission/Microseismic Activity. Volume 1: Principles, Techniques and Geotechnical Applications*. A.A. Balkema, Lisse, Netherlands.
- Holcomb, D. (1983): Using acoustic emissions to determine in-situ stress: problems and promise. *Geomechanics*, ASME, AMD, 57, 11-21.
- Holcomb, D. (1985): Summary of discussions on behaviour of solids with a system of cracks. *Mechanics of geomaterials: rocks, concretes, soils*. J. Wiley, New York, 571-573.
- Holcomb, D., and Martin, R. (1985): Determining peak stress history using acoustic emissions. *Proceedings of 26<sup>th</sup> U.S. Symposium on Rock Mechanics*, A.A. Balkema, Rotterdam, 715-722.
- Hou, Z., Li, C., Song, Z., Xiao, Y., Qiao, C., and Wang, Y. (2021): Investigation on Acoustic Emission Kaiser Effect and Frequency Spectrum Characteristics of Rock Joints Subjected to Multilevel Cyclic Shear Loads. *Geofluids*. doi:10.1155/2021/5569525
- Hsieh, A., Dight, P., and Dyskin, A. (2015): The rock stress memory unrecoverable by the Kaiser effect method. *International Journal of Rock Mechanics and Mining Sciences*, 75, 190-195. doi:10.1016/j.ijrmms.2015.01.006
- Hughson, D., and Crawford, A. (1986): Kaiser effect gauging: A new method for determining the pre-existing in-situ stress from an extracted core by acoustic emissions. *Proceedings of the International Symposium of Rock Stress and Rock Stress Measurements*, Stockholm, Centek Publishers, 359-368.
- Jian-Hong, W., Hung-Ming, L., and Yu-You, C. (2017): Rock core-based pre-stress evaluation experimental validation: A case study on Yutengping Sandstone as CO<sub>2</sub> storage reservoir rock. *TAO: Terrestrial, Atmospheric and Oceanic Sciences*, 28, 3, 193-207. doi:10.3319/TAO.2015.09.21.02(GSC)
- Jin, Y., Qi, Z., Chen, M., Zhang, G., and Xu, G. (2009): Time-sensitivity of the Kaiser effect of acoustic emission in limestone and its application to measurements of in-situ stress. *Petroleum Science*, 6, 2, 176-180. doi:10.1007/s12182-009-0028-6
- Jingen, D., Kangping, W., and Rongzun, H. (1995): In-situ stress determination at great depth by using acoustic emission technique. *Proceedings of the 35<sup>th</sup> US Symposium on Rock Mechanics*, Reno, 245-250.
- Kaiser, J. (1950): An investigation into the occurrence of noises in tensile tests, or a study of acoustic phenomena in tensile tests. Doctor of Philosophy Thesis, Technical University of Munich, Munich, Germany.

- Kanagawa, T., Hayashi, M., and Nakasa, H. (1976): Estimation of spatial geostress in rock samples using the Kaiser effect, Rep. 375017, Central Research Institute of Electric Power Industry, Abiko, Japan.
- Kent, L., Bigby, D., Coggan, J., and Chilton, J. (2002): Comparison of acoustic emission and stress measurement results to evaluate the application of the Kaiser effect for stress determination in underground mines. Proceedings of the 21<sup>st</sup> International Conference on ground control in mining, Morgantown, West Virginia, USA, 270–277.
- Kharghani, M., Goshtasbi, K., Nikkiah, M., and Ahangari, K. (2021): Investigation of the Kaiser effect in anisotropic rocks with different angles by acoustic emission method. *Applied Acoustics*, 175, p. 107831. doi:10.1016/j.apacoust.2020.107831
- Kurita, K., and Fujii, N. (1979): Stress memory of crystalline rocks in acoustic emission. *Geophysical Research Letters*, 6, 1, 9-12.
- Kyriazis, P., Anastasiadis, C., Triantis, D., and Vallianatos, F. (2006): Wavelet analysis on pressure stimulated currents emitted by marble samples. *Natural Hazards and Earth System Sciences*, 6, 6, 889-894. doi:10.5194/nhess-6-889-2006
- Lavrov, A. (2003): The Kaiser effect in rocks: principles and stress estimation techniques. *International Journal of Rock Mechanics and Mining Sciences*, 40, 2, 151-171. doi: 10.1016/S1365-1609(02)00138-7
- Lavrov, A., Vervoort, A., Wevers, M., and Napier, J. (2002): Experimental and numerical study of the Kaiser effect in cyclic Brazilian tests with disk rotation. *International Journal of Rock Mechanics and Mining Sciences*, 39, 3, 287-302. doi:10.1016/S1365-1609(02)00038-2
- Lehtonen, A., Cosgrove, J., Hudson, J., and Johansson, E. (2012): An examination of in situ rock stress estimation using the Kaiser effect. *Engineering Geology*, 124, 24-37. doi:10.1016/j.enggeo.2011.09.012
- Lehtonen, A., and Särkkä, P. (2006): Evaluation of rock stress estimation by the Kaiser effect. In Lu, M., Li, C.C., Kjørholt, H., Dahle, H., (eds.): *In-situ Rock Stress*. Taylor & Francis Group, London, 135-142. doi:0.1201/9781439833650.ch18
- Li, C. (1998): A theory for the Kaiser effect in rock and its potential applications. *Series on rock and soil mechanics*, 171-185.
- Li, C., and Nordlund, E. (1993): Assessment of damage in rock using the Kaiser effect of acoustic emission. *International journal of rock mechanics and mining sciences & geomechanics abstracts*, 30, 943-946. doi:10.1016/0148-9062(93)90049-J
- Li, C., and Nordlund, E. (1993): Experimental verification of the Kaiser effect in rocks. *Rock Mechanics and Rock Engineering*, 26, 4, 333-351. doi:10.1007/BF01027116
- Li, H., and Zhang, B. (2003): Laboratory determination of in-situ stress tensor using AE method. Proceedings of the International symposium on rock stress, 267-270.
- Liang, C., Ma, J., Zhou, P., Ma, G., & Xu, X. (2020): Fracture Damage Properties of SBS-Modified Asphalt Mixtures Reinforced with Basalt Fiber after Freeze-Thaw Cycles Using the Acoustic Emission Approach. *Applied Sciences*, 10, 9, 3301. doi: 10.3390/app10093301
- Ljunggren, C., Chang, Y., Janson, T., and Christiansson, R. (2003): An overview of rock stress measurement methods. *International Journal of Rock Mechanics and Mining Sciences*, 40, 7-8, 975-989. doi:10.1016/j.ijrmmms.2003.07.003
- Meng, Q., Chen, Y., Zhang, M., Han, L., Pu, H., and Liu, J. (2019): On the Kaiser effect of rock under cyclic loading and unloading conditions: insights from acoustic emission monitoring *Energies*, 12, 17, 3255. doi:10.3390/en12173255
- Michihiro, K., Yohioka, H., Hata, K., and Fujiwara, T. (1985): Strain dependence of the Kaiser effect for various rocks. Proceedings of the 4<sup>th</sup> Conference of Acoustic Emission/Microseismic Activity in Geologic Structure and Material, The Pennsylvania State university, October. Trans Tech Publications, Clausthal, Germany.
- Momayez, M., and Hassuni, E. (1992): Application of Kaiser effect to measure in-situ stresses in underground mines. Proceedings of the 33rd US Symposium on Rock Mechanics. A.A. Balkema, 979–988.
- Montoto, M., and Hardy, H.R. (1991): Kaiser effect in intact rock: current status as a feasible means of evaluating thermal and mechanical loading. Proceedings of 7<sup>th</sup> International Congress on Rock Mechanics, Aachen, Deutschland, 569–572.
- Nikkiah, M. (2013): Study and Numerical modeling of Influence of Triaxial Loading on the Kaiser Effect (Publication Number 5574). PhD thesis, Tarbiat Modares University. Tehran. (in Persian)
- Nikkiah, M. (2017): Numerical assessment of influence of confining stress on Kaiser effect using distinct element method. *Journal of Mining and Environment*, 8, 2, 215-226. doi:10.22044/jme.2016.674
- Nikkiah, M., Ahmadi, M., and Ghazvinian, A. (2011): Application of pattern recognition analysis of rock acoustic emission for determination of Kaiser Effect. Proceedings of 12<sup>th</sup> International Congress on Rock Mechanics, China. 765-769.
- Pestman, B., and Van Munster, J. (1996): An acoustic emission study of damage development and stress-memory effects in sandstone. *International journal of rock mechanics and mining sciences & geomechanics abstracts*, 33, 6, 585-593. doi:10.1016/0148-9062(96)00011-3
- Seto, M., Nag, D., and Vutukuri, V. (1999): In-situ rock stress measurement from rock cores using the acoustic emission method and deformation rate analysis. *Geotechnical & Geological Engineering*, 17, 3, 241-266. doi:10.1023/A:1008981727366
- Seto, M., Utagawa, M., and Katsuyama, K. (2002): Some fundamental studies on the AE method and its application to in-situ stress measurements in Japan. Proceedings 5<sup>th</sup> International Workshop on the Application of Geophysics in Rock Engineering, Toronto, Canada, 67-71.
- Seto, M., Utagawa, M., Katsuyama, K., and Kiyama, T. (1998): In Situ Stress determination using AE and DRA techniques. *International Journal of Rock Mechanics and Mining Sciences*, 4, 35, 458-459. doi:10.1016/S0148-9062(98)00118-1
- Seto, M., and Villaescusa, E. (1999): In situ stress determination by acoustic emission techniques from McArthur River

- mine cores. Proceedings of 8<sup>th</sup> Australia New Zealand Conference on Geomechanics, Hobart, Australia, 929-934.
- Soundararajan, V., Atharifar, H., and Kovacevic, R. (2006): Monitoring and processing the acoustic emission signals from the friction-stir-welding process. Proceedings of the Institution of Mechanical Engineers, Part B: Journal of Engineering Manufacture, 220, 10, 1673-1685. doi:10.1243/09544054JEM586
- Srinivasan, V., Gupta, T., Ansari, T., and Singh, T. (2020): An experimental study on rock damage and its influence in rock stress memory in a metamorphic rock. Bulletin of Engineering Geology and the Environment, 79, 8, 4335-4348. doi:10.1007/s10064-020-01813-y
- Stuart, C., Meredith, P., Murrell, S., and Van Munster, J. (1993): Anisotropic crack damage and stress-memory effects in rocks under triaxial loading, Anisotropic crack damage and stress-memory effects in rocks under triaxial loading, International Journal Rock Mechanics Mining Science Geomechanics Abstracts, 30, 7, 937-941. doi:10.1016/0148-9062(93)90048-i
- Tang, C., Chen, Z., Xu, X., and Li, C. (1997): A theoretical model for Kaiser effect in rock. Pure and applied geophysics, 150, 2, 203-215. doi:10.1007/s000240050073
- Tuncay, E., and Obara, Y. (2012): Comparison of stresses obtained from acoustic emission and compact conical-ended borehole overcoring techniques and an evaluation of the Kaiser effect level. Bulletin of Engineering Geology and the Environment, 71, 2, 367-377. doi:10.1007/s10064-011-0362-y
- Vervoort, A., and Govaerts, A. (2006): Kaiser effect in tri-axial tests of limestone samples. Proc Monogr Eng Water Earth Science, 2006, 143-149. doi:10.1201/9781439833650.ch19
- Villaescusa, E., Li, J., and Seto, M. (2002): Stress measurements from oriented core in Australia. Proceedings 5<sup>th</sup> International Workshop on the applications of geophysics in rock engineering, Toronto, Canada, 71-77.
- Villaescusa, E., Li, J., Windsor, C., and Seto, M. (2006): A comparison of overcoring and AE stress profiles with depth in Western Australian Mines. Proceedings of international conference on in-situ rock stress, Taylor & Francis Group, Trondheim, 223-228. doi:10.1201/9781439833650.ch29
- Villaescusa, E., Windsor, C., Li, J., Baird, G., and Seto, M. (2003): Stress measurements from cored rock. Minerals and Energy Research Institute of Western Australia, Research Report (233), 124. doi:10.1016/S1365-1609(02)00059-X
- Wang, G., Wang, W., Fang, Q., Jiang, H., Xin, Q., and Xue, B. (2018): The application of discrete wavelet transform with improved partial least-squares method for the estimation of soil properties with visible and near-infrared Spectral Data. Remote Sensing, 10, 6, 867-884. doi:10.3390/rs10060867
- Wang, H., Xian, X., Yin, G., and Xu, J. (2000): A new method of determining geostresses by the acoustic emission Kaiser effect. International journal of rock mechanics and mining sciences, 37, 3, 543-547.
- Wang, Y., Chen, S., Liu, S., and Hu, H. (2016): Best wavelet basis for wavelet transforms in acoustic emission signals of concrete damage process. Russian Journal of Nondestructive Testing, 52, 3, 125-133. doi:10.1134/S1061830916030104
- Yang, D., Ning, Z., Li, Y., Lv, Z., and Qiao, Y. (2021): In situ stress measurement and analysis of the stress accumulation levels in coal mines in the northern Ordos Basin, China. International Journal of Coal Science & Technology, 8, 6, 1316-1335. doi:10.1007/s40789-021-00407-7
- Yoshikawa, S., and Mogi, K. (1978): Kaiser effect of acoustic emission in rocks-influences of water and temperature disturbances. Proceedings of the 4<sup>th</sup> Acoustic Emission Symposium, Tokyo, Japan. 22-40.
- Yu, R., Tian, Y., and Wang, X. (2015): Relation between stresses obtained from Kaiser effect under uniaxial compression and hydraulic fracturing. Rock Mechanics and Rock Engineering, 48, 1, 397-401. doi:10.1007/s00603-014-0573-1
- Yuan, R., and Li, Y. (2008): Theoretical and experimental analysis on the mechanism of the Kaiser effect of acoustic emission in brittle rocks. Journal of University of Science and Technology Beijing, Mineral, Metallurgy, Material, 15, 1, 1-4. doi:10.1016/S1005-8850(08)60001-8
- Zhang, Y., Okere, C. J., and Su, G. (2021): Effect of loading rates on accurate in-situ stress determination in different lithologies via Kaiser effect. Arabian Journal of Geosciences, 14, 14, 1-8. doi:10.1007/s12517-021-07674-3
- Zhao, K., Deng, F., Jin, J., He, G., and Liu, H. (2006): Wavelet analysis of Kaiser signal of rock acoustic emission and its application. Chinese Journal of Rock Mechanics and Engineering, 25, 2, 526-530.
- Zhao, K., Gu, S., Yan, Y., Zhou, K., Li, Q., and Zhu, S. (2018): A simple and accurate interpretation method of in situ stress measurement based on rock kaiser effect and its application. Geofluids, 2018, 1-13. doi:10.1155/2018/9463439
- Zhao, K., Zhi, X., Wang, X., Jin, J., and Wang, G. (2008): Advances in Kaiser effect of rock acoustic emission based on wavelet analysis. In: Cai, M. and Wang, J. (eds.) Boundaries of Rock Mechanics. CRC Press, 993-996.

## SAŽETAK

### Pregled primjene Kaiserova efekta u mjerenju *in situ* naprezanja u stijenama

Poznavanje *in situ* naprezanja u stijenskoj masi jedan je od važnijih aspekata u mnogim inženjerskim problemima. Postoje različite metode za određivanje *in situ* naprezanja. Većina uobičajenih metoda koje se koriste za određivanje *in situ* naprezanja vremenski su i financijski zahtjevne te je u mnogim slučajevima potrebna posebna pristupačnost. Stoga se sve više pažnje posvećuje metodama temeljenim na ispitivanjima provedenim na jezgrama. Jedna je od tih metoda i metoda akustičke emisije koja se temelji na Kaiserovu efektu. Ubraja se u metode naprezanja postupcima opterećenja i rasterećenja, a temelji se na promatranju ponašanja stijena bez znatnoga utjecaja na nju. Poznavanje principa akustičke emisije i parametara akustičkoga signala prvi je korak u primjeni metode za određivanje *in situ* naprezanja na temelju Kaiserova efekta. Nadalje, primjena metode Kaiserova efekta zahtijeva razumijevanje mehanizma i teorije povezane s Kaiserovim efektom. U ovome istraživanju razmatrane su različite metode za određivanje Kaiserova efekta u okviru parametara (metoda tangente i maksimalni nagib itd.) i obrade signala (Fourierova transformacija, valična transformacija i sl.). Pored navedenog, rezultati dobiveni metodom Kaiserova efekta uspoređeni su s drugim uobičajenim metodama koje se koriste za mjerenje *in situ* naprezanja, kao što su *overcoring* metoda i metoda hidrauličkoga frakturiranja te je na temelju rezultata ustanovljena znatna podudarnost između njih. Također su istraženi ključni parametri za određivanje točke naprezanja kod Kaiserova efekta. Ključni parametri bili su postupak ispitivanja, ograničavajući tlak, fizička svojstva stijene, vrijeme kašnjenja i vrijeme zadržavanja, smjer i količina opterećenja, kut anizotropije i brzina opterećenja.

#### Ključne riječi:

*in situ* naprezanje, akustička emisija, Kaiserov efekt, obrada signala, valična transformacija

#### Author's contribution

**Mohammadmahdi Dinmohammadpour** (1) (PhD candidate), **Majid Nikkhah** (2) (Assistant Professor at the Faculty of Engineering), **Kamran Goshtasbi** (3) (Professor at the Faculty of Engineering) and **Kaveh Ahangari** (4) (Associate Professor at the Faculty of Engineering) shared contributions in collecting different studies, as well as defined and compared Kaiser effect applications in the in-situ measurement of rocks.