

Optimisation of Aluminium Halls in the Republic of Croatia - Numerical Study

Davor SKEJIĆ*, Anđelo VALČIĆ, Ivan ČUDINA

Abstract: In this paper, numerical optimisation of aluminium prefabricated halls is made considering different wind and snow load zones in the Republic of Croatia. The main structural system is a portal frame with a tension-tie element. Standard frame spans of 10 to 20 meters and heights of 3 to 6 meters were analysed. Beams and columns were made of EN AW-6005 A aluminium alloy using extruded rectangular profiles $230 \times 90 \times 3$ mm with slots. In the joint zones, aluminium profiles were connected using 180×80 mm tubular steel knee inserts with thicknesses varying from 3 to 6 mm made of structural steel S 235 or S 355. Parametric analyses were performed to find the optimal geometry of steel inserts in terms of uniform utilisation of aluminium and steel cross-sections for all considered frame geometries and load zones. Also, the material consumption is discussed. Based on the performed analyses, the preliminary geometry of the frame with their maximum allowable distances is proposed. These results can be used for cost estimations of the optimal disposition of aluminium halls in the Republic of Croatia.

Keywords: optimisation methodology; parametric analysis; prefabricated aluminium hall; steel knee joint insert; tension-tie element

1 INTRODUCTION

It is well known that after steel, aluminium is the most commonly used metal in structural engineering. Due to its mechanical properties, it cannot sufficiently compete with steel in terms of load-bearing capacity and serviceability. However, due to its low specific weight, corrosion resistance and functionality of the construction form, it is accepted as a construction material and competes with steel precisely because of the above-mentioned advantages related to physical properties [1]. While the development of new aluminium alloys is constantly progressing, mainly through the use of new alloying elements and modern production processes, e.g., powder metallurgy, the most suitable alloys for structural applications are those from the 5xxx and 6xxx series at the moment [2, 3]. As the welding of aluminium alloys causes a considerable reduction of mechanical properties in a localized region known as the heat-affected zone [4], the connections of the aluminium elements are mainly carried out with bolts and additional steel plates or steel profiles.

One of the most common applications of aluminium in structural engineering are prefabricated aluminium halls, which are usually designed as portal frames with or without high-grade steel tension-tie elements. For larger spans (more than 10 m), the most rational solution is the portal frame with a high-grade steel tension-tie element with steel reinforcements placed at the beam-to-beam and beam-to-column joints. When the steel tie element is used, the most economical type of reinforcement is a steel tubular knee joint insert. Since the force in such joints is transmitted partly through bolts and partly through the complex contact mechanism, expressions for reliability assessment are still non-existent. To investigate this complex behaviour, laboratory testing of aluminium knee joints with steel insert was conducted at the Faculty of Civil Engineering, University of Zagreb [5, 6]. Based on this research, it was concluded that all specimens fail due to weld failure between the beam tube section and the tensile bolt nut. Also, numerical analyses [6] showed that the effect of the softer tension-tie element leads to more favourable ductile behaviour of these joints.

As aluminium alloys are obtained by a relatively expensive extrusion process, especially for "small"

aluminium hall manufacturers [7], it is unprofitable to produce several profiles as each profile requires a separate extrusion die. This is exactly the reason why there is a need for the optimisation of aluminium halls built from a small number of typical profiles. Therefore, this paper aims to provide a standardised procedure for optimal preliminary disposition solution of the aluminium halls in the Republic of Croatia. To minimize costs and facilitate the process of selecting the optimal structural system, parametric analysis that includes relevant load values throughout the Republic of Croatia (snow and wind) and structure parameters in terms of frame span, the distance between frames as well as thickness, length and steel quality of the insert is performed.

2 STRUCTURAL SYSTEMS OF ALUMINIUM HALLS

2.1 General

Prefabricated aluminium halls are mostly used as temporary structures where advantages of easier transport, quick assembly and disassembly are pronounced due to the aluminium low specific weight, which is three times less than the specific weight of steel. They can be used as fast and reliable shelters during hazard events like the 6,4-magnitude earthquake that struck central Croatia (Petrinja region) in the December of 2020, Fig. 1. An additional advantage of aluminium structures is the lower maintenance requirements. Due to their corrosion resistance, aluminium halls most often represent the only efficient and economical solution in climate aggressive areas.



Figure 1 Typical shelters made from aluminium alloys after the earthquake in the city of Petrinja [8]

Depending on their use, whether permanent or temporary, different design regulations apply. For permanent structures, the reliability verification needs to be carried out according to a set of structural standards EN 199x, while for temporary structures, the EN 13782 standard is applied [9]. Demountable (temporary) structures are often used for longer service life, and it is important to take this into account during the analysis and design of such structures. The main structural systems of prefabricated aluminium halls, shown in Fig. 2, span from

5 to 30 m, with heights of up to 7,5 meters at the ridge [10]. For such structures, the most common type of roof covering is non-flammable PVC foil, but corrugated steel sheets/panels can be used as well. Furthermore, extruded aluminium members have unlimited possibilities regarding the shape of the cross-section. Accordingly, rectangular profiles with beadings for the assembly of PVC foil cover are most commonly used. Such members are usually connected at beam-to-column or beam-to-beam joints using steel cover plates or steel inserts.

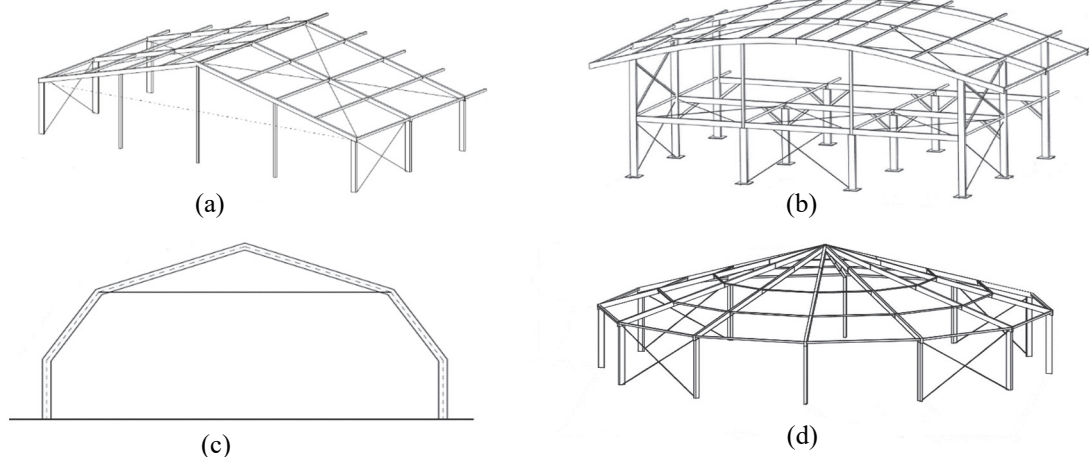

Figure 2 Main structural systems: (a) portal frame with straight beams; (b) portal frame with curved beams; (c) polygonal frames; (d) half-frames in radial array [10]

2.2 Analysed Structural System

To conduct a series of parametric analyses, a portal frame with high-grade steel tension-tie element was chosen as a structural system, Fig. 3. The initial distance between the main portal frames is one (1) meter. According to [6], high-grade steel tension tie element is often used to reduce

bending in the knee joint (instead of CHS elements) for spans greater than 10 meters (typically $\text{Ø}16,6 \times 37 + \text{FC}$, 1770 MPa). Hence, the tension tie element is modelled as a $\text{Ø}16$ steel bar. It is the only fixed parameter along with the aluminium cross-section and slope of the roof which is, from the aspect of roof cover functionality, selected as 15° .

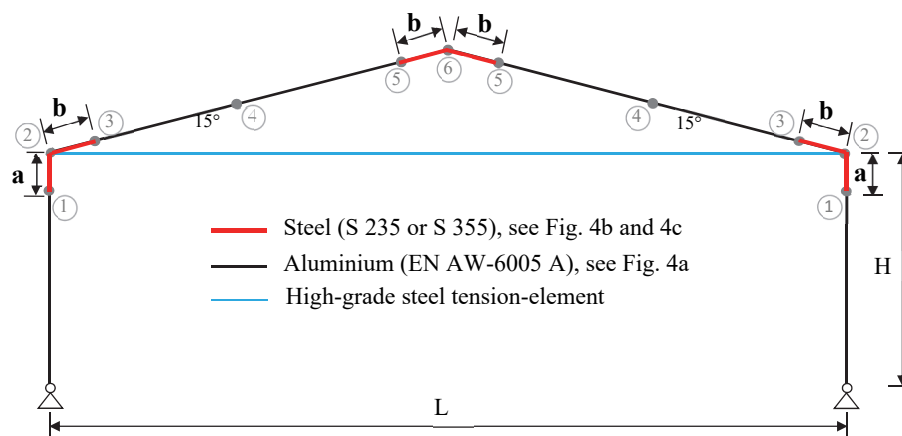

Figure 3 Analysed structural system of aluminium hall

Since the utilisation is observed on the cross-sectional bending resistance, several characteristic points (Fig. 3) of bending moment values can be highlighted: (1) - in the column at the end of the steel insert, (2) - at the eave, (3) - in the beam at the end of the steel insert (closer to the eave), (4) - at the place of the highest hogging moment in the beam, (5) - in the beam at the end of the steel insert (closer to the ridge) and (6) - at the ridge. In Fig. 3, a represents the length of the steel insert in the column, while b represents the length of the steel insert in the beam.

Lengths of $H/5$, $H/10$, and $H/15$ were selected for the column part of the insert, where H is the column height at the eaves. Also, insert lengths in the beams were taken as $L/10$, $L/20$, $L/30$, and $L/40$, where L is the span of the structural frame.

Beams and columns are made of rectangular aluminium profile $230 \times 90 \times 3$ mm, with beadings for the assembly of PVC foil cover, Fig. 4a. Bolted beam-to-column joints are reinforced using steel welded tubular knee inserts, Fig. 5.

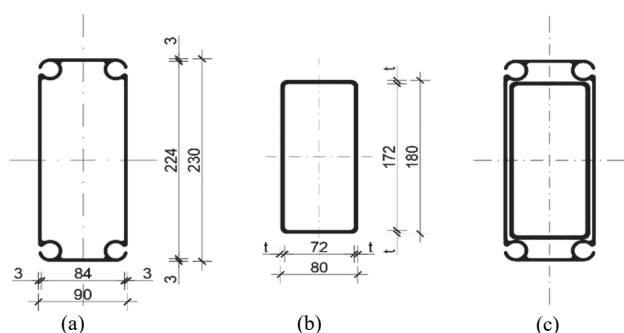

Figure 4 (a) aluminium profile; (b) steel insert; (c) cross-section at the knee joint [11] - Dimensions are in mm

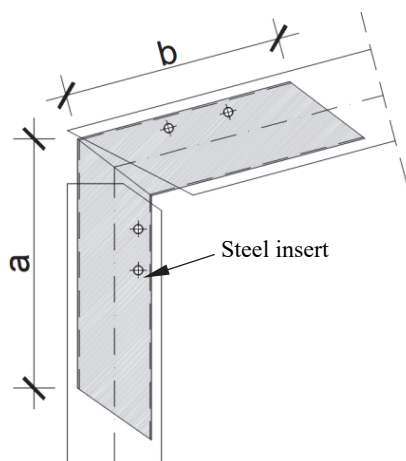

Figure 5 Assembled tubular knee joint [11]

With the aim of simplification, only steel cross-section, without aluminium, is modelled in the joint zone. Dimensions of the steel insert cross-section are 180×80 mm, Fig. 4b, while the thickness and steel quality are variable parameters. Fig. 4c shows the aluminium cross-section reinforced with a steel insert at the knee joint zone.

3 AIM AND SCOPE OF PARAMETRIC ANALYSIS

3.1 General

The main assumption of this parametric analysis is that it is made only at the resistance of the cross-section level and serves for the preliminary selection of the optimum geometry (disposition) of the hall. Final optimisation should be carried out accounting for the stability problems of aluminium columns and beams.

As stated earlier, the numerical optimisation was conducted with the assumption that the initial distance between the portal frames is one (1) meter. Accordingly, the load values per m^2 acting on the surface of the hall and the load values per m' acting on the relevant frame are equal. The goal is to obtain a uniform utilisation of load-bearing elements by performing static analysis, and consequently, increase the distance between the frames to achieve the optimum preliminary geometry of the portal frame. To obtain the desired level of frame utilisation, by increasing or reducing the distance between the frames, the maximum utilisation can be reduced or increased, respectively. By increasing the frame distance, the number of required portal frames can be reduced, and consequently, the total weight of steel and aluminium can

be reduced, as well. Furthermore, by changing the geometrical properties of the steel insert, moment redistribution in the frames can be achieved to obtain a more uniform level of utilisation.

The optimum lengths of the steel inserts (in column and beam) are obtained from a model that gives uniform distribution of the extreme moment values in the aluminium elements (at points 1, 3, 4, and 5). On the other hand, optimal geometry of the steel insert should be defined in such a manner that the ratios of the extreme moments in aluminium and steel correspond to the ratio of the (elastic) bending resistance of the aluminium, Eq. (1), according to [12], and plastic bending resistance of steel cross-sections, Eq. (2), according to [13]:

$$M_{al,Rd} = \frac{W_{el} \cdot f_o}{\gamma_{M1}} \quad (1)$$

$$M_{st,Rd} = \frac{W_{pl} \cdot f_y}{\gamma_{M0}} \quad (2)$$

where:

- W_{el} elastic section modulus of the aluminium profile,
- W_{pl} plastic section modulus of the steel insert profile,
- f_o characteristic value of 0,2% proof strength,
- f_y yield strength,
- γ_{M1} partial factor for resistance of cross-sections ($\gamma_{M1} = 1,1$) according to [12],
- γ_{M0} partial factor for resistance of cross-sections ($\gamma_{M0} = 1,0$) according to [13].

3.2 Geometrical and Mechanical Properties

The main structural system of analysed prefabricated aluminium halls is a portal frame with a tension-tie element (all spans are greater or equal to 10 m). Parametric analysis was performed with frame heights of 3 to 6 m in the eaves, and spans of 10 to 20 m. The frames were calculated with different lengths and thicknesses of steel inserts to obtain their optimal geometry. Inserts made of both structural steel S235 and S355 were considered. The summary of all varied parameters can be found in Tab. 1.

Table 1 Range of parameters for analysis

Parameter	Range and values
Span, L / m	10, 12, 14, 16, 18, 20
Height, H / m	3, 4, 5, 6
Thickness of the steel insert, t / mm	3, 4, 5, 6
Steel quality grade	S 235, S 355
Length of steel insert in column, a	$H/5, H/10, H/15$
Length of steel insert in beam, b	$L/10, L/20, L/30, L/40$

3.3 Systematisation of Croatian Load Zones

The geographical position and geomorphological diversity are the cause of very uneven snow and wind loads in the Republic of Croatia. Lightweight structures, such as ones made from aluminium, are particularly susceptible to snow and wind loads due to their low self-weight. The Republic of Croatia is dominated by three main climate zones: continental, mountainous, and coastal. The main climate modifiers, the Adriatic Sea, the Dinarides and the Pannonian Plain, cause a very complex flow regime,

leading to significant differences in climatic load values all over the country. While the Croatian Meteorological and Hydrological Service constantly works on updating the snow and wind maps, in the current versions of national amendment documents (NADs) [14, 15], a modern methodology for statistical processing of measurement results at measuring stations throughout the Republic of Croatia for a return period of 50 years has been applied. For the territory of the Republic of Croatia, four different snow zones are defined [14]. Relevant altitudes for each snow zone were selected where the application of such halls is realistic from the aspect of populated regions. Snow and wind loads were combined into seven load combinations (load zones), regarding four snow load zones, Tab. 2. For each load zone, two load combinations were considered: one with maximum snow load and corresponding wind load, and one with maximum wind load and corresponding snow load. For load zone 4, only load combination with maximum snow load was

considered as the combination with maximum wind load was already taken into account with this extreme.

Design load values were calculated according to [14] and [15] for snow and wind loads, respectively. The shape coefficient for the roof was taken as $\mu = 0,8$ since the slope of the roof beam is 15° . Drifted arrangement of the snow load was not included in the parametric analysis as the undrifted snow load arrangement proved to be the governing load case for the final design.

It can be concluded from Tab. 2 that the zone with maximum wind load is zone 1B, while the zone with maximum snow load is zone 4. Moreover, zones 3B and 4 include places with high altitudes and are usually less populated, so there is less need for using such prefabricated halls. Based on the variation of the parameters shown in Tab. 1 and the systematisation of Croatian load zones (7 different load zones), 864 numerical models were analysed in total.

Table 2 Load zones with accompanying snow and wind characteristic load values

Snow load zone	Characteristic places (Load zone)	Altitude / m	Snow load on the ground, s_k / kN/m ²	Basic wind speed, v_b / m/s
(1) Coast and islands	Zadar (1A)	10	0,50	30
	Pag, Zubovići (1B)	15	0,50	48
(2) Hinterland of Dalmatia, Primorje and Istria	Knin (2A)	214	0,75	40
	Gospić (2B)	656	2,00	25
(3) Continental Croatia	Kutjevo (3A)	226	1,50	20
	Plešivica (3B)	383	1,75	25
(4) Mountain Croatia	Udbina (4)	830	4,50	20

4 PARAMETRIC STUDY RESULTS AND DISCUSSION

4.1 General

Typical bending moment distributions in portal frames with dominant snow and wind load are shown in Fig. 6. Bending moment values on the left and the right-hand side of the presented diagrams are not necessarily the same, Fig. 6.

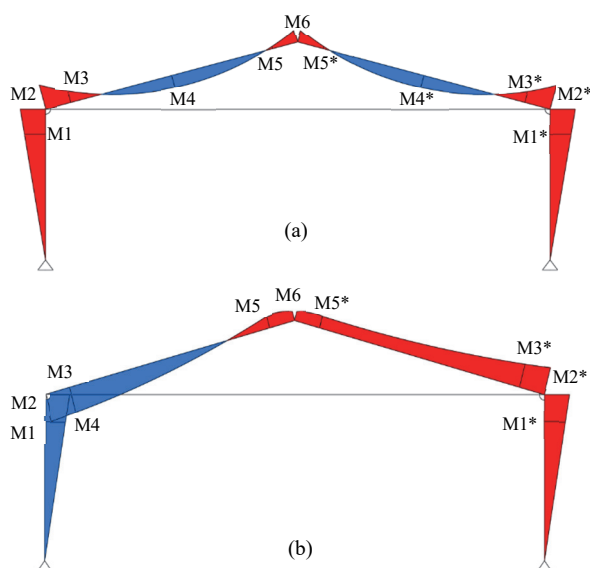

Figure 6 Typical bending moment distributions for zones with dominant: (a) snow load; (b) transversal wind load

Hence, only maximum moment values were observed, regardless of the moment distribution. Among all the stated parameters in Tab. 1, different bending moment distributions also represent an unavoidable factor when

finding the optimum utilisation. It should be stressed that the bending moment value at point 1, M1, is never higher than the bending moment value at point 2, M2.

Table 3 Ratios of bending resistance

Aluminium	Steel		Bending resistance ratio		
	$M_{st,Rd}$		$M_{st,Rd}/M_{al,Rd}$		
	t / mm	Steel grade		Steel grade	
29,0			S 235	S 355	S 235
	3	20,2	30,5	0,70	1,05
	4	26,3	39,8	0,91	1,37
	5	31,7	47,9	1,09	1,65
	6	36,9	55,7	1,27	1,92

Based on the data given in Tab. 3, it is evident that for 3 and 4 mm thick steel inserts with steel quality S 235 the design bending resistance of aluminium, $M_{al,Rd}$, is higher than the plastic bending resistance of steel, $M_{st,Rd}$ (shaded in grey). In all the other cases, the bending resistance of the steel insert is higher compared to the bending resistance of the aluminium cross-section. Since the analysed aluminium hall is considered for permanent use, design load actions are calculated according to [14, 15], while calculation of cross-section bending resistance is conducted according to Eq. (1) and Eq. (2), respectively [12].

4.2 Results and Optimisation

In most cases, the results of the parametric analysis show that the overall resistance of the frame is governed by the resistance in point 2 where the maximum bending moment in steel occurs, Fig. 6. Accordingly, depending on utilisation in point 2, the optimal geometry of the steel insert can be determined. Given a large number of

numerical models (864) that were analysed, it is impractical to present the results for all thicknesses and lengths of the steel inserts, as well as for all corresponding frame spans and heights. Consequently, in the following table (Tab. 4) only the results for frames with 4 mm thick

steel inserts, made of S 355 steel grade, are presented. Such configurations are chosen as they are shown to be optimal in most analysed cases. Therefore, the results for steel inserts with a thickness of 3, 5 and 6 mm are neither analysed nor discussed in this paper.

Table 4 Frame utilisation and optimal lengths for 4 mm thick inserts made of steel grade S 355

Eave Height / m	Span / m	Insert length		Load zone	Eave Height / m	Span / m	Insert length		Load zone	
		<i>a</i>	<i>b</i>				<i>a</i>	<i>b</i>		
3	10-20	<i>H/6-H/5</i>	<i>L/30-L/20</i>	1A	3,0	10, 12	<i>H/6-H/5</i>	<i>L/20</i>	1B	
		-	-			14-20	-	-		
4,5	10-18	<i>H/6-H/5</i>	<i>L/20-L/10</i>		4,5	4,5	10	<i>H/5</i>		<i>L/10</i>
		-	-				12-20	-		-
6	10-18	<i>H/6-H/5</i>	<i>L/10</i>		6,0	6,0	10-20	-		-
		-	-				-	-		-
3	10-14	<i>H/6-H/5</i>	<i>L/30-L/20</i>	2A	3,0	10-18	<i>H/5</i>	<i>L/40-L/30</i>	2B	
		-	-			20	-	-		
4,5	10, 12	<i>H/7-H/5</i>	<i>L/10</i>		4,5	4,5	10-16	<i>H/5</i>		<i>L/30-L/20</i>
		-	-				18, 20	-		-
6	10-20	-	-		6,0	6,0	10-14	<i>H/5</i>		<i>L/20-L/10</i>
		-	-				16-20	-		-
3	10-20	<i>H/5</i>	<i>L/40-L/30</i>	3A, 3B	3,0	10-14	<i>H/5</i>	<i>L/40</i>	4	
		-	-			16-20	-	-		
4,5	10-20	<i>H/5</i>	<i>L/40-L/30</i>		4,5	4,5	10, 12	<i>H/5</i>		<i>L/40</i>
		-	-				14-20	-		-
6	10-18	<i>H/5</i>	<i>L/20-L/10</i>		6,0	6,0	10	<i>H/5</i>		<i>L/30</i>
		-	-				12-20	-		-

Notes:
 - zones 1A, 1B, 2A - dominant wind load, Tab. 2
 - zones 2B, 3A, 3B, 4 - dominant snow load, Tab. 2
 - fields highlighted in grey represent spans with corresponding heights that have no potential for use

Insight into the results of the parametric analysis (see fields in Tab. 4 highlighted in grey) has shown that halls with spans over 10 m (in rare cases 12 m) cannot be used in zones 1B and 4 since they do not meet the design requirements (high wind load and/or high snow load). A similar conclusion can be applied for zone 2A, where spans greater than 14 m (except for the 3 m eave height) are not reliable for usage. On the contrary, in zones 1A, 2B, 3A and 3B, it has been shown that such specific structural systems, at almost all the analysed spans with corresponding heights, have the potential for use, and thus for optimisation. To present the proposed optimisation process, i.e., methodology, as well as the results, in the following chapters two zones for dominant snow load (1A,

2A) and two zones for dominant wind load (2B, 3A) are displayed. One shorter and one longer span ($L = 12$ m and 18 m) were taken under consideration for each load zone. For both spans, height at the eave was taken as $H = 3$ m. It should be noted that selected spans and heights of the structural system are for demonstration purposes only.

4.2.1 Zones 1A and 2A (Dominant Wind Load)

In this section, utilisation diagrams for a 12 m and 18 m span frame with the height of 3 m in the eave are presented, regarding zone 1A ($s_k = 0,50$ kN/m², $v_b = 30$ m/s) and zone 2A ($s_k = 0,75$ kN/m², $v_b = 40$ m/s).

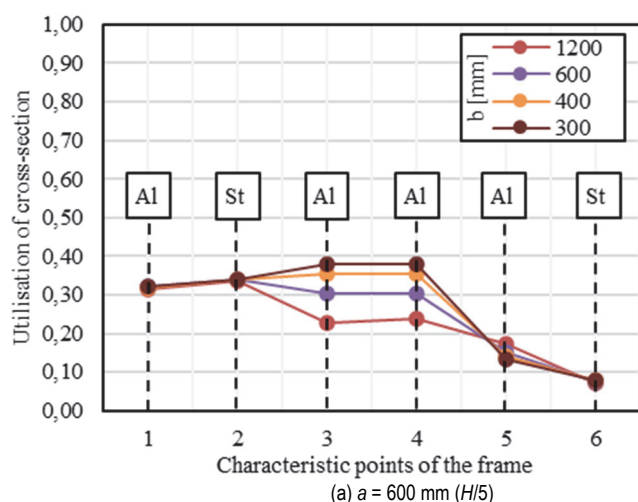

Figure 7 Cross sectional utilisation of frame members for varying beam insert lengths, b : $L = 12$ m, $H = 3$ m, $t = 4$ mm, S 355 (zone 1A)

The distribution of cross-section utilisation in points 1 to 6, Fig. 3, is presented for the zone 1A in Fig. 7 and

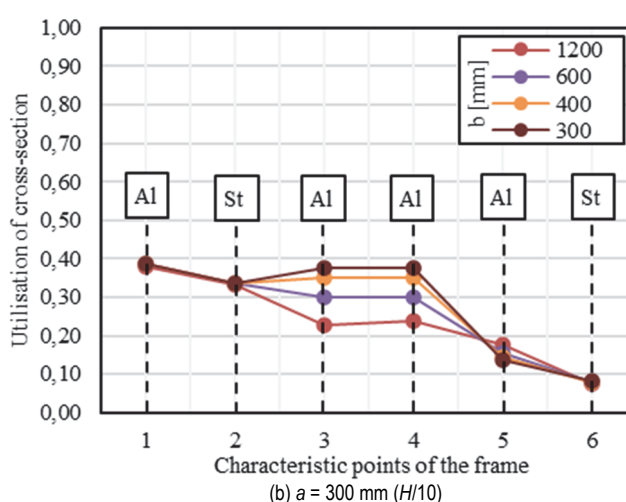

Fig. 9, and for the zone 2A in Fig. 8, depending on different geometries of the steel inserts. Note that 18 m span frame

is not presented for zone 2A. This can be clearly seen and justified from Tab. 4, where 16-20 m frame spans for the 3 m height in the eave, do not satisfy the ultimate limit state, i.e., design requirements. Considering chosen spans, the utilisation distribution for steel inserts with the length in the column of $a = 600$ mm ($H/5$) is presented in Fig. 7a, Fig. 8a and Fig. 9a, and for $a = 300$ mm ($H/10$) in Fig. 7b, Fig. 8b and Fig. 9b. Also, presented diagrams include different insert lengths in the beam, b . For 12 m span, the above-mentioned lengths are 1200 mm ($L/10$), 600 mm ($L/20$), 400 mm ($L/30$), 300 mm ($L/40$), and for the frame with 18 m span those values are 1800 mm ($L/10$), 900 mm ($L/20$), 600 mm ($L/30$) and 450 mm ($L/40$).

Regarding zone 1A, Fig. 7, it is shown that for 12 m span frames with the height of 3 m in the eave and 4 mm thick steel insert, the most uniform utilisation is achieved for the length of the insert in the beam of 400 mm ($L/30$) and 600 mm ($L/20$) for 600 mm ($H/5$) insert length in

column, Fig. 7a. For 300 mm ($H/10$) insert length, the uniform utilisation is reached using 300 mm ($L/40$) and 400 mm ($L/30$) long beam steel inserts, Fig. 7b. Moreover, for zone 2A, Fig. 8, the utilisation results regarding steel insert geometry correlate with the results for zone 1A. The difference is visible only in the percentage of utilisation for the equivalent geometry of the steel inserts. For a specific 12 m span frame located in zone 1A, Fig. 7a and Fig. 7b, utilisation level is much lower compared to utilisation level of frame with the same characteristics located in zone 2A, Fig. 8a and Fig. 8b. Results for the 18 m frame spans, Fig. 9, can also be related to the results shown for the 12 m frame spans. Similarity is manifested in equal optimal lengths of the steel inserts, which is 600 mm ($L/30$) and 900 mm ($L/20$) for insert length in column of 600 mm ($H/5$), while for 300 mm ($H/10$) column insert, optimal beam inserts are 450 mm ($L/40$) and 600 mm ($L/30$).

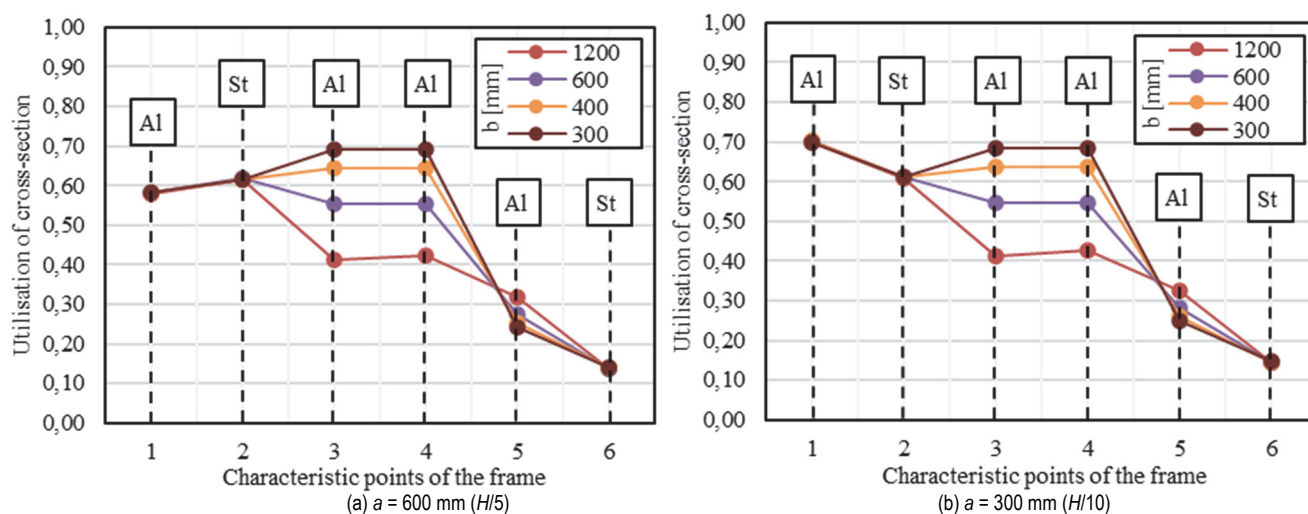

Figure 8 Cross sectional utilisation of frame members for varying beam insert lengths, b : $L = 12$ m, $H = 3$ m, $t = 4$ mm, S 355 (zone 2A)

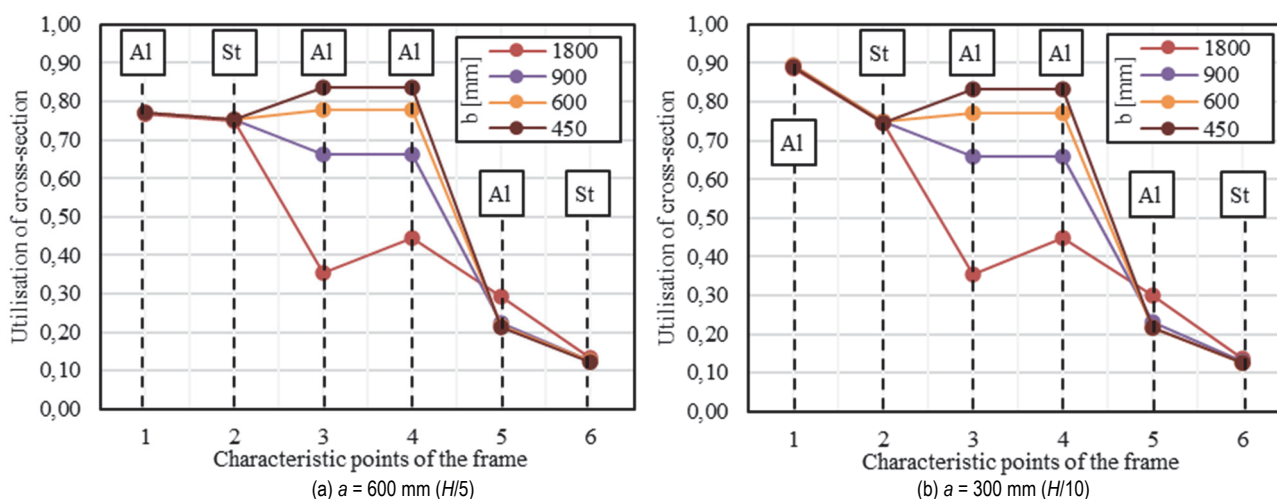

Figure 9 Cross sectional utilisation of frame members for varying beam insert lengths, b : $L = 18$ m, $H = 3$ m, $t = 4$ mm, S 355 (zone 1A)

With the aim of attaining the optimum length of the insert in the column, a , utilisation diagrams for 12 m spans, as a representative example, are made specifically for two lengths of the inserts in the beam, $b = 400$ mm ($L/30$), Fig. 10a, and $b = 600$ mm ($L/20$), Fig. 10b, for both load zones 1A and 2A. As can be seen from Fig. 10, the utilisation of steel insert cross-section slightly varies depending on the length of the insert in the column.

The cross-sectional utilisation level of the aluminium, Fig. 10, decreases as the length of the insert in the column increases. The optimum lengths of the inserts can be determined from the intersection of the lines (M1 and M2) in Fig. 10. For $b = 400$ mm ($L/30$), Fig. 10a, the optimum length of the insert in the column, a , would be approximately $H/6$ (530 mm). By increasing the length of the beam insert to $b = 600$ mm ($L/20$), Fig. 10b, the optimal

length of the insert in the column would be approx. $a = 500$ mm ($H/6$). Note that the utilisation curves are approximated as linear paths between calculated utilisation values. However, such a simplification had a negligible error (approx. 1%) in determining the optimal section

length in the column. Consequently, it will not make any difference as the optimal distance between the frames would still be the same: for zone 1A - 2,8 m ($1/0,35$) and for zone 2A - 1,6 m ($1/0,62$).

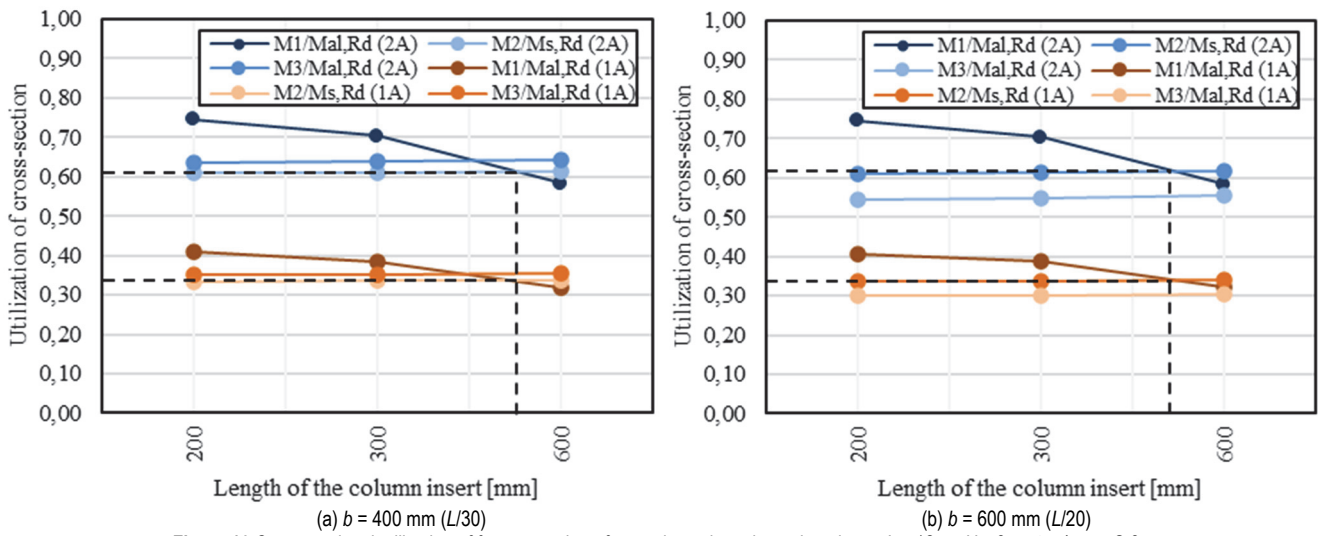

Figure 10 Cross sectional utilisation of frame members for varying column insert lengths, $a = L = 12$ m, $H = 3$ m, $t = 4$ mm, S 355

4.2.2 Zones 2B and 3A (Dominant Snow Load)

For zones with dominant snow load, 2B ($s_k = 2,00$ kN/m², $v_b = 25$ m/s) and 3A ($s_k = 1,50$ kN/m², $v_b = 20$ m/s), cross-sectional utilisation results are also given for 12 m and 18 m span frames with the height of 3 m at the eave. Regarding zone 2B, Figs. 11 and 13 and zone 3A, Figs. 12 and 14, utilisation diagrams are shown for frames with 4 mm thick steel inserts made of S 355 steel quality grade. Both in zones 2B and 3A, frames with inserts lengths in the column, $a = 600$ mm ($H/5$) and $a = 300$ mm ($H/10$) are considered. Beam steel insert lengths, b , taken into account are 450 mm ($L/40$), 600 mm ($L/30$), 900 mm ($L/20$) to 1800 mm ($L/10$) in the case of 18 m span frame. On the other hand, for a 12 m span frame, steel insert lengths in the beam part that are included in the optimisation process are 300 mm ($L/40$), 400 mm ($L/30$), 600 mm ($L/20$) and 1200 mm ($L/10$).

Namely, for zone 2B (Figs. 11 and 13) including both considered spans, the most uniform cross-sectional utilisation is achieved for steel insert lengths in the beam

of ($L/40$) and ($L/30$), for both insert lengths in the column of $a = 600$ mm ($H/5$) (Fig. 11a and Fig. 13a), and $a = 300$ mm ($H/10$) (Fig. 11b and Fig. 13b). Similar to zone 2B, for zone 3A, considering the same frame geometries, the most uniform cross-sectional utilisation is achieved for the same insert lengths in the column and the beam, like ones for zone 2B, Figs. 12 and 14. Moreover, it can be seen that for zone 3A, in the case of larger spans (Fig. 14), except for insert length in the beam $b = 1800$ mm, cross-sectional utilisation is relatively equal in all the points. Thus, it can be concluded that cross-sectional utilisation diagrams for zone 3A most closely resemble the ideal utilisation diagram compared to other zones when larger spans are considered. To determine the optimum steel insert length in the column, utilisation diagrams with the respect to insert length in the column were made. In this section, 18 m span frame is considered, with lengths of the insert in the beam of $b = 600$ mm ($L/30$) and $b = 450$ mm ($L/40$), for zone 2B, Fig. 15a and Fig. 15b, and for zone 3A, Fig. 16a and Fig. 16b.

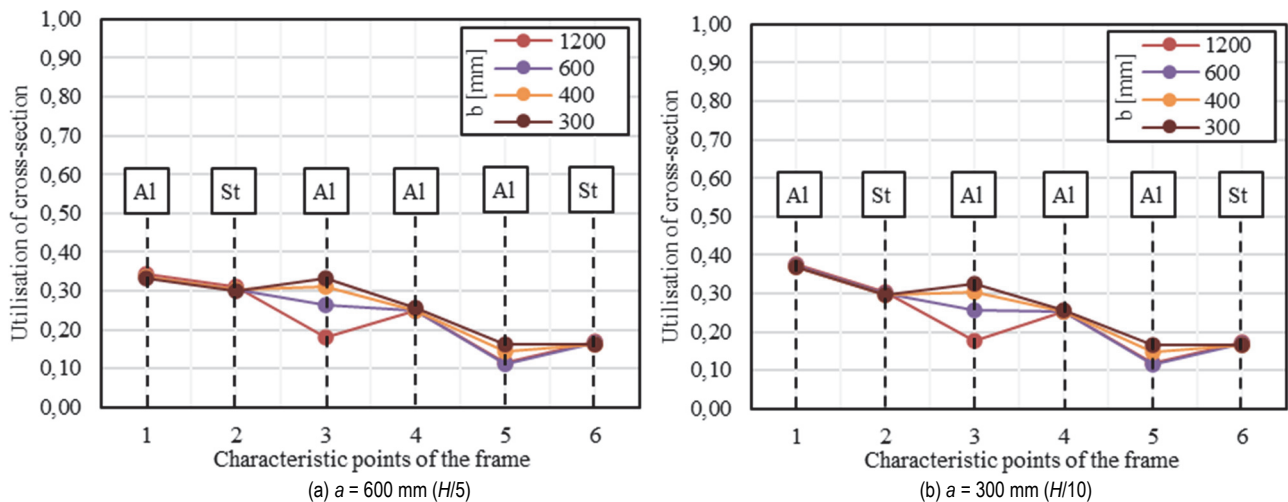

Figure 11 Cross sectional utilisation of frame members for varying beam insert lengths, $b: L = 12$ m, $H = 3$ m, $t = 4$ mm, S 355 (zone 2B)

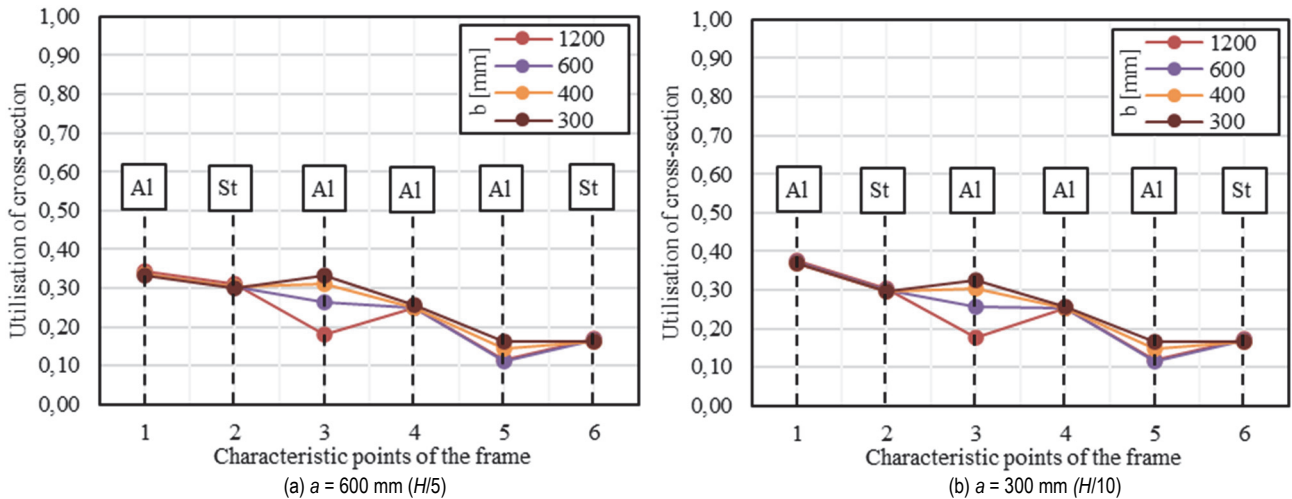

Figure 12 Cross sectional utilisation of frame members for varying beam insert lengths, b : $L = 12$ m, $H = 3$ m, $t = 4$ mm, S 355 (zone 3A)

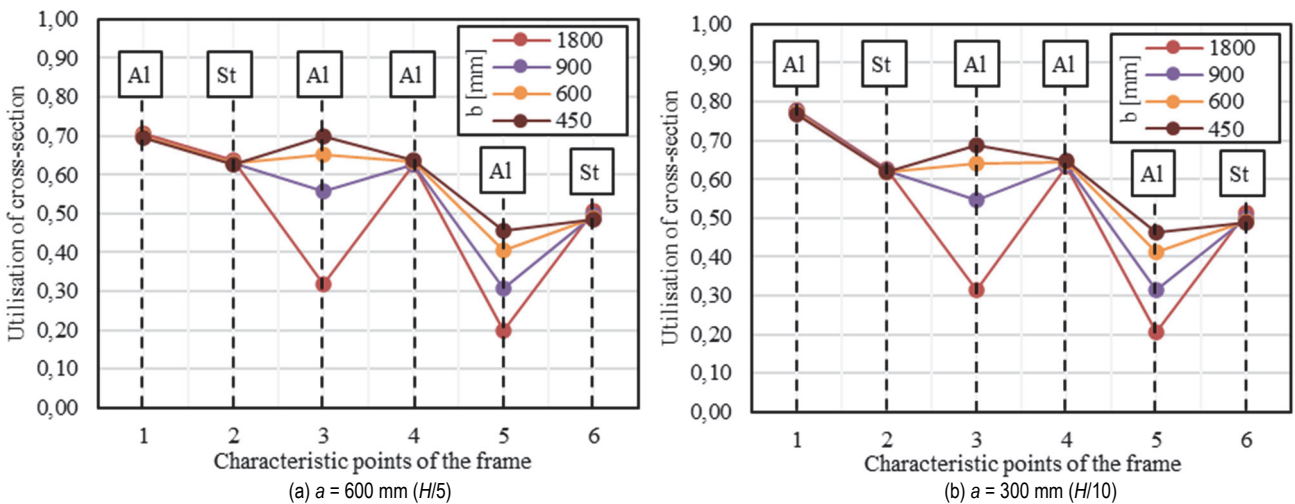

Figure 13 Cross sectional utilisation of frame members for varying beam insert lengths, b : $L = 18$ m, $H = 3$ m, $t = 4$ mm, S 355 (zone 2B)

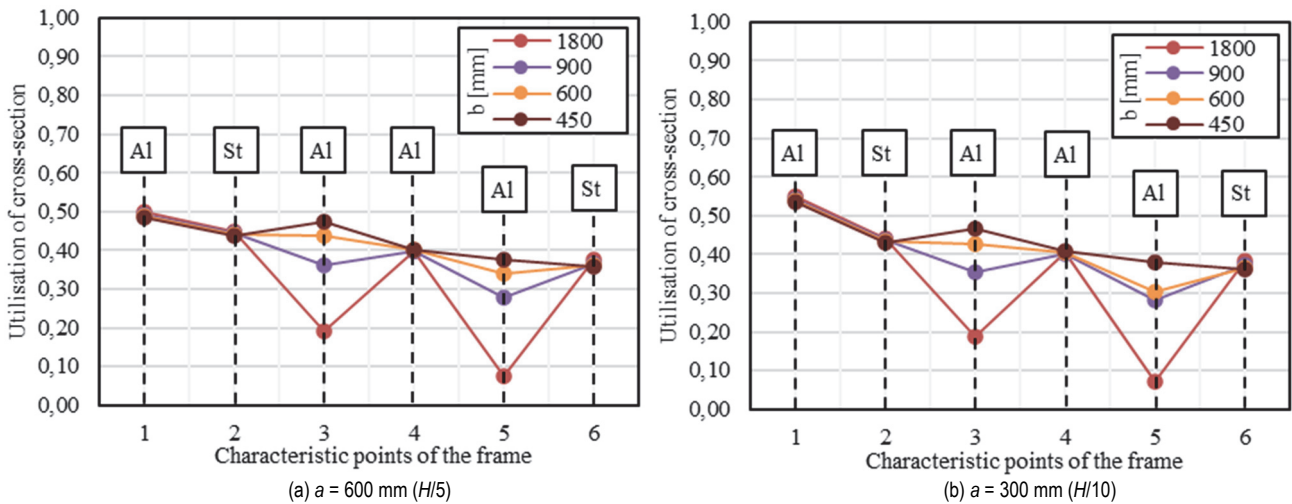

Figure 14 Cross sectional utilisation of frame members for varying beam insert lengths, b : $L = 18$ m, $H = 3$ m, $t = 4$ mm, S 355 (zone 3A)

Since the optimum insert length is obtained at the intersection of the aluminium and steel cross-sectional utilisation lines, it can be concluded that the optimal length of the insert in the column is approx. 820 mm for zones 2B and 3A, Figs. 15 and 16 in the case of 18 m spans. The cross-sectional utilisation for optimal insert length in the column is 63% for zone 2B, both for insert length in the beam $b = 600$ mm, Fig. 15a, and $b = 450$ mm, Fig. 15b. Following the same guiding principle for zone 3A, by

choosing the optimum insert length in the column, cross-sectional utilisation of 45% is achieved, Fig. 16a and Fig. 16b. Consequently, the maximal allowable distance between the frames can be determined. For zone 2B, Fig. 15, frames could be placed at a distance of approx. 1,5 m ($1/0,63 = 1,58$ m) when using optimal insert geometry. Accordingly, the optimal distance between the frames could be 2,2 ($1/0,45$) m for zone 3A.

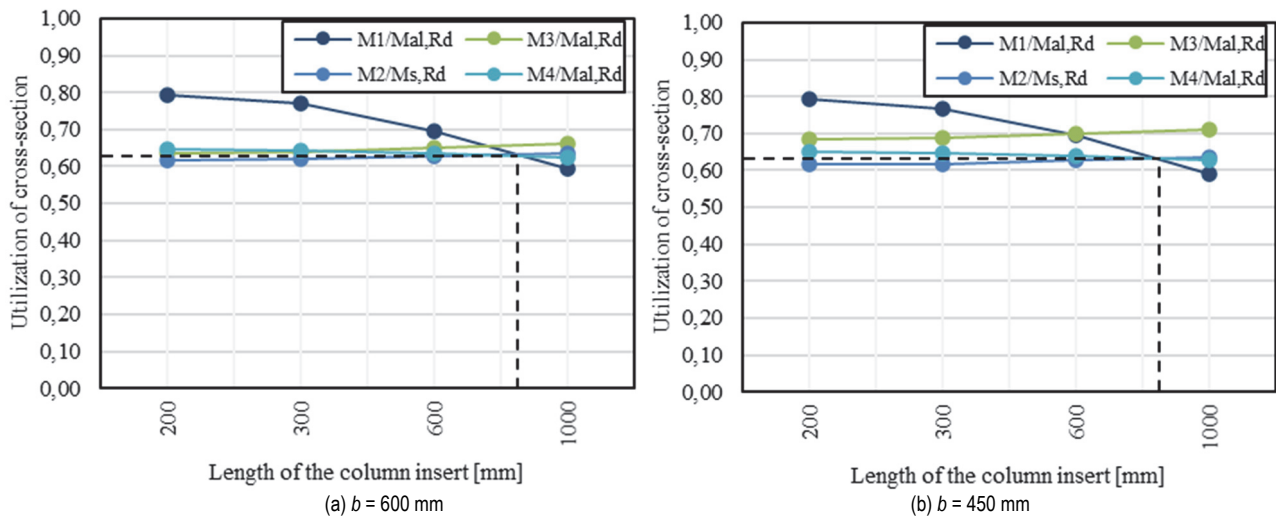

Figure 15 Cross sectional utilisation of frame members for varying column insert lengths, a: $L = 18$ m, $H = 3$ m, $t = 4$ mm, S 355 (zone 2B)

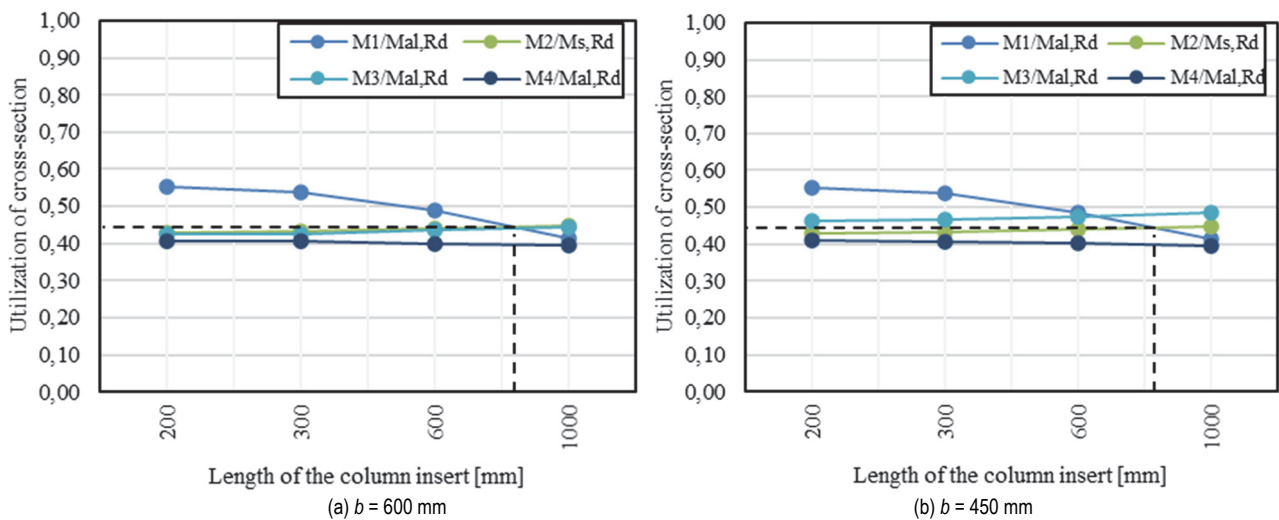

Figure 16 Cross sectional utilisation of frame members for varying column insert lengths, a: $L = 18$ m, $H = 3$ m, $t = 4$ mm, S 355 (zone 3A)

4.3 Material Consumption

Generally, construction project cost estimation is of crucial importance for the investors, but also for manufacturers. Material consumption represents a key part of the bidding process as it helps to determine an appropriate offer. The quickness with which a correct offer can be made is, however, based on the idea of optimisation, which in turn is based on choosing the optimal geometry of steel (thickness and length of the inserts) and the distance between the frames (total material consumption - both steel and aluminium). Although the third dimension, i.e., the length of the hall, is not considered in this paper, the material consumption (in terms of mass) is analysed for an optimal frame configuration. A particular frame geometry (12 m span with a height of 3 m at the eave) with optimal insert lengths in the beam part, as well as in the column part, is compared regarding two dominant load zones. In Fig. 17, the material consumption is presented for optimal frame configuration, regarding zone 2A (dominant wind load) and zone 3A (dominant snow load). Tension tie element is not considered in mass consumption. Fig. 17a and Fig. 17b show that steel was used 10% more for zone 2A compared to zone 3A, in terms of mass. Of course, for both zones and optimal frame geometries, the consumption

of steel is much lower than the consumption of aluminium, which reduces the weight of the construction considerably.

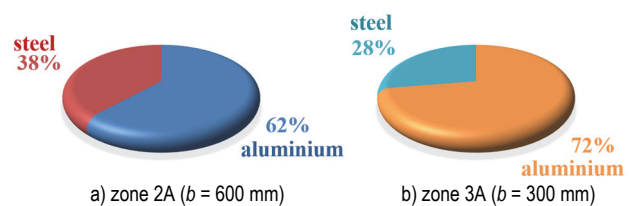

Figure 17 Material consumption (in terms of mass) for a frame: $L = 12$ m span, $H = 3$ m; $a = 600$ mm

With tension tie element included in the consumption, the ratio between aluminium and steel consumption would be approx. equal for both considered zones and optimal frame configurations.

5 CONCLUSION

Based on the performed analyses the preliminary geometry of the frame and the maximum spacing between frames can be proposed. Generally, the use of steel inserts with a thickness of 4 mm and steel grade S 355 is recommended for all load zones.

In load zones with dominant wind load (1A, 1B, 2A), see Tab. 2, the optimal length of the steel inserts in the column is approx. $H/7$, and in the beam approx. between $L/30$ and $L/20$. In load zones with dominant snow loads (2B, 3A, 3B and 4), see Tab. 2, inserts with shorter lengths of the beam part ($L/30$ and $L/40$) gave more uniform cross-sectional utilisation in the frame. For these zones, parametric study should be extended to account for steel inserts with length in column $a = H/3$, to investigate if frame utilisation could be further reduced, and consequently, the distance between the frames increased. Using inserts with greater lengths of the column insert would also lead to a higher consumption of the steel in the frame, but it could be justified if the space between frames could be sufficiently increased leading to overall material reduction. Beam insert lengths of $L/10$ have never proven to be the optimal solution, except, in rare cases, for the greater heights at the eave.

The performed analyses showed that the utilisation of steel inserts and aluminium frame members is more uniform in the zones with dominant snow load compared to zones with dominant wind load. In areas with higher snow load, the utilisation level of the frame can be significantly reduced when using steel inserts with longer column part, while in zones with dominant wind load, the lengths of the steel insert in the column should be taken as $H/5$ or less.

The material usage ratio between aluminium and steel is far more (3-4 times) on the side of aluminium in all zones, when tension tie element is not included into account.

It should be noted that optimisation methodology presented in this paper may be applied in general for other countries, but since loads are related to the regions of the Republic of Croatia, final findings are only valid for the stated country.

Since detailed experimental and numerical investigations of beam-to-column joints have already been carried out, future research should include global behaviour of these frame systems. Hence, the presented study can be used as a fairly good basis for the preliminary determination of the geometry and estimation of construction costs.

6 REFERENCES

- [1] Mazzolani, F. M. (2006). Structural Applications of Aluminium in Civil Engineering. *SEI, IABSE Journal*, 16(4), 280-285. <https://doi.org/10.2749/101686606778995128>
- [2] Skejić, D., Boko, I., & Torić, N. (2015). Aluminium as a material for modern structures. *Građevinar*, 67(11), 1075-1085. <https://doi.org/10.14256/JCE.1395.2015>
- [3] Dokšanović, T., Džeba, I., & Markulak, D. (2017). Applications of aluminium alloys in civil engineering. *Tehnički vjesnik*, 24(5), 1609-1618. <https://doi.org/10.17559/TV-20151213105944dfb>
- [4] Zhu, J.-H., Young, B. (2006). Tests and Design of Aluminium Alloy Compression Members. *Journal of Structural Engineering*, 132(7), 1096-1107. [https://doi.org/10.1061/\(ASCE\)0733-9445\(2006\)132:7\(1096\)](https://doi.org/10.1061/(ASCE)0733-9445(2006)132:7(1096))
- [5] Skejić, D., Mazzolani, F. M., Čurković, I., & Damjanović, D. (2019). Experimental testing of prefabricated aluminium knee joints reinforced by steel. *14th International Aluminium Conference (INALCO2019): Environmental Advantages of*

Sustainable Aluminium Structures - Sustainability, Durability and Life Cycle, Tokyo, Japan

- [6] Skejić, D., Čudina, I., Garašić, I., & Mazzolani, F. M. (2021). Behaviour of Steel Tubular Knee Joint in Aluminium Frames with Tension-Tie Element. *Applied Science*, 11(70). <https://doi.org/10.3390/app11010070>
- [7] Boko, I., Skejić, D., & Torić, N. (2017). *Aluminium structures*. Textbook at University of Split and textbook at University of Zagreb.
- [8] Petrinja-1 (2021, January 9). Retrieved from <https://medjimurjexpress.net/>
- [9] European Committee for Standardization (CEN). Temporary structure -- Tents -- Safety (EN 13782:2015)
- [10] Skejić, D., Orehovec, D., & Čurković, I. (2021). Prefabricated Aluminium Halls. *Građevinar*, 73(2), 141-151. <https://doi.org/10.14256/JCE.2627.2019>
- [11] Kumerle, V. (2020). *Standardization of aluminium halls in the Republic of Croatia*. Master's thesis, University of Zagreb, Faculty of Civil Engineering.
- [12] European Committee for Standardization (CEN). Eurocode 9: Design of aluminium structures -- Part 1-1: General structural rules (EN 1999-1-1:2007+A1:2009+A2:2013)
- [13] European Committee for Standardization (CEN). Eurocode 3: Design of steel structures -- Part 1-1: General rules and rules for buildings (EN 1993-1-1:2005/A1:2014)
- [14] European Committee for Standardization (CEN). Eurocode 1: Actions on structures -- Part 1-3: General actions -- Snow loads (EN 1991-1-3:2003/A1:2015)
- [15] European Committee for Standardization (CEN). Eurocode 1: Actions on structures -- Part 1-4: General actions -- Wind actions

Contact information:

Davor SKEJIĆ, PhD, Full Professor
(Corresponding author)
University of Zagreb, Faculty of Civil Engineering,
Fra Andrije Kačića-Miošića 26, HR-10000 Zagreb, Croatia
E-mail: davor.skejic@grad.unizg.hr

Andelo VALČIĆ, PhD Candidate
University of Zagreb, Faculty of Civil Engineering,
Fra Andrije Kačića-Miošića 26, HR-10000 Zagreb, Croatia
E-mail: andelo.valcic@grad.unizg.hr

Ivan ČUDINA, PhD Candidate
University of Zagreb, Faculty of Civil Engineering,
Fra Andrije Kačića-Miošića 26, HR-10000 Zagreb, Croatia
E-mail: ivan.cudina@grad.unizg.hr